

# Conclamp Type A with Terminal Block **pro-POWER**

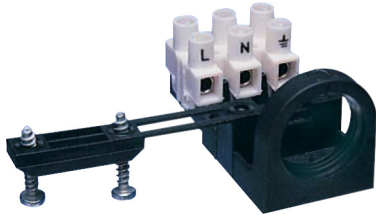

## Description

The Conclamp System is designed to combine the functions of cable entry and secure clamping and allows the additional facility of incorporating a terminal block. The Conclamp creates a safe entry for cable when used in conjunction with a hole bush or cable gland, preventing damage caused by movement against sharp edges. Once within the unit the cable is held securely using the Conclamp's integral cable clamp. Finally the cable can be terminated into the snap-on terminal block.

## Features

- High cable retention
- Right-hand assembly with terminal block
- Press-in chassis mounting

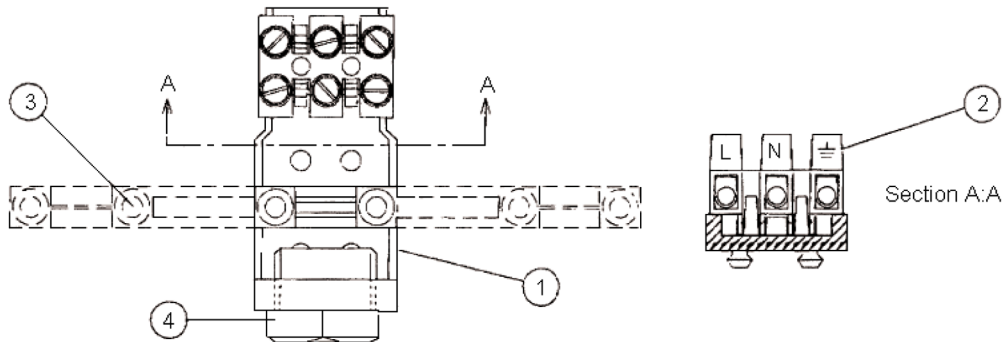

Item	Description	Material
1	455-0020 Type A L/H Pegs	Nylon 6.6
2	455-0010 Type A R/H Pegs	
3	11.0-5060 T. Block	-
4	700-0070 Screw	Steel
5	47B Bush	Nylon 6.6

## Part Number Table

Description	Thread Dimensions	Overall Dimensions	Part Number
Conclamp Type A Right-Hand Assembly with Terminal Block	M20	59mm × 28mm	455-9660

**Important Notice :** This data sheet and its contents (the "Information") belong to the members of the Premier Farnell group of companies (the "Group") or are licensed to it. No licence is granted for the use of it other than for information purposes in connection with the products to which it relates. No licence of any intellectual property rights is granted. The Information is subject to change without notice and replaces all data sheets previously supplied. The Information supplied is believed to be accurate but the Group assumes no responsibility for its accuracy or completeness, any error in or omission from it or for any use made of it. Users of this data sheet should check for themselves the Information and the suitability of the products for their purpose and not make any assumptions based on information included or omitted. Liability for loss or damage resulting from any reliance on the Information or use of it (including liability resulting from negligence or where the Group was aware of the possibility of such loss or damage arising) is excluded. This will not operate to limit or restrict the Group's liability for death or personal injury resulting from its negligence. pro-POWER is the registered trademark of the Group. © Premier Farnell plc 2012.