

DKBT BLUETOOTH SMART READY DEVELOPMENT KIT
USER GUIDE

Thursday, 16 April 2015

Document Version: 1.1



A Silicon Labs Company

Copyright © Silicon Labs

All rights reserved.

Silicon Labs assumes no liability or responsibility for any errors, mistakes or inaccuracies in content. Silicon Labs reserves the right to change products or specifications without notice, and does not make any commitment to update the information herein.

Silicon Labs' products are not authorized for use as critical components in life support devices or systems.

The *Bluetooth*® word mark and logos are registered trademarks owned by the *Bluetooth*® SIG, Inc. USA.

All other trademarks and trade names listed herein belong to their respective owners.

Information is subject to change without notice.

VERSION HISTORY

Date Edited	Comment
1.0	First release of document
1.1	Minor changes

TABLE OF CONTENTS

1	Introduction	5
1.1	Package contents	5
2	DKBT overview	6
2.1	DKBT functional block diagram	7
3	Interpreting the silk screens	8
4	Power supply options	9
4.1	Powering with a 1.5V AAA battery	9
4.2	Powering through USB	9
4.3	Powering using an external power supply	9
5	Measuring the current consumption	11
5.1	Measuring average currents with a DMM	13
5.2	Measuring sleep currents with a DMM	13
5.3	Measuring peak currents with an oscilloscope	14
6	Peripherals	15
6.1	Buttons and LEDs	16
6.2	Potentiometer	16
6.3	Current sense and 0mA reference	16
6.4	LCD display	17
6.5	SPI accelerometer	18
6.6	I ² C altimeter	19
7	Related documentation	20
8	Contact information	21

1 Introduction

This document describes the DKBT Bluetooth Smart Ready development kit hardware and contains useful information about the development kit hardware as well as instructions on how to use it.

DKBT Bluetooth Smart Ready enables easy evaluation of Bluegiga Bluetooth Smart Ready modules and serves as a platform for developing Bluetooth Smart Ready applications.

1.1 Package contents

DKBT is delivered with the parts shown in [Figure 1](#) below.

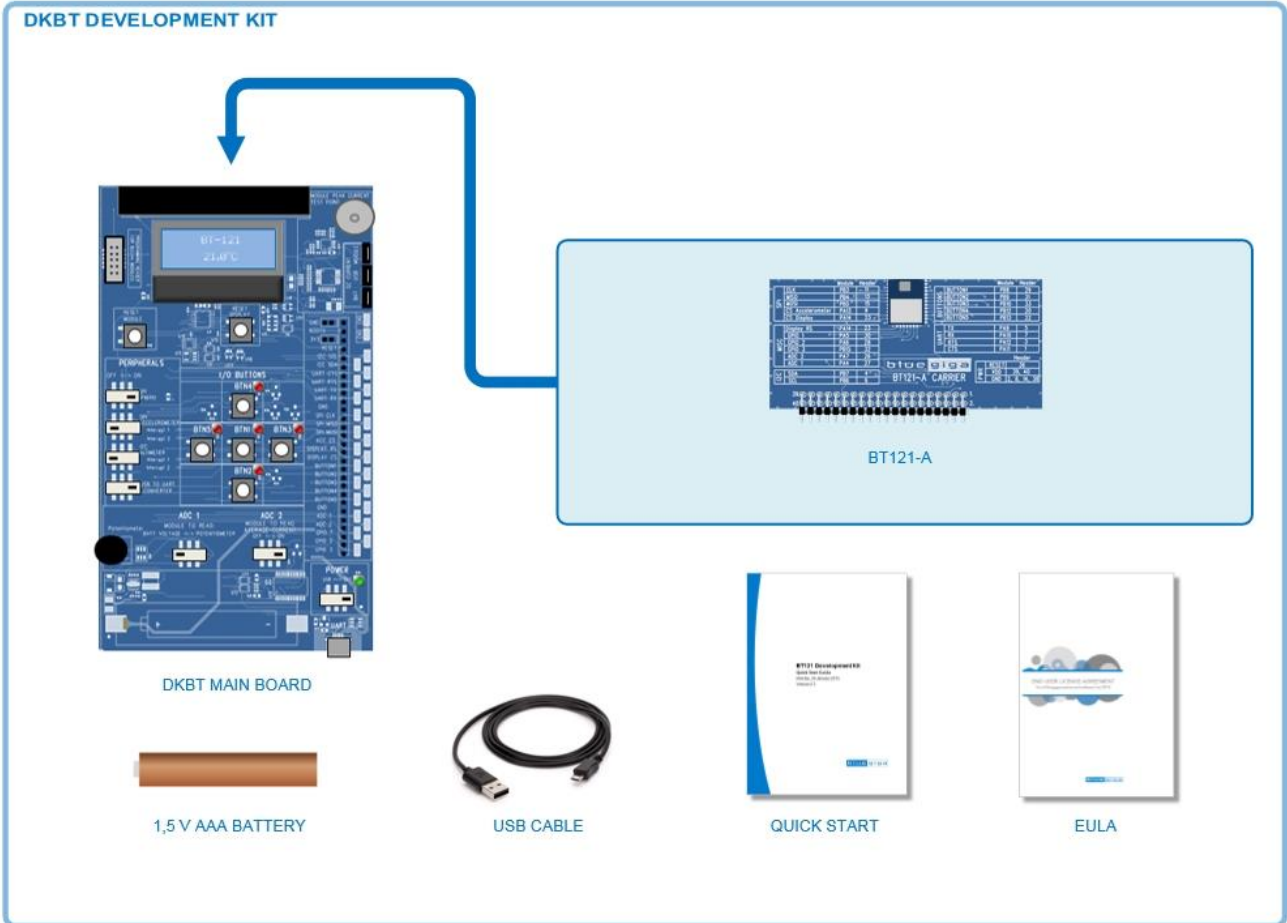

Figure 1: DKBT development kit contents

2 DKBT overview

This section introduces the functional layout of the DKBT main board and the BT121 Bluetooth Smart Ready module carrier board.

An overview of the functional layout of DKBT board and BT121 carrier board is shown in [Figure 2](#) below. The corresponding functional block diagram is shown in [Figure 3](#) on the following page.

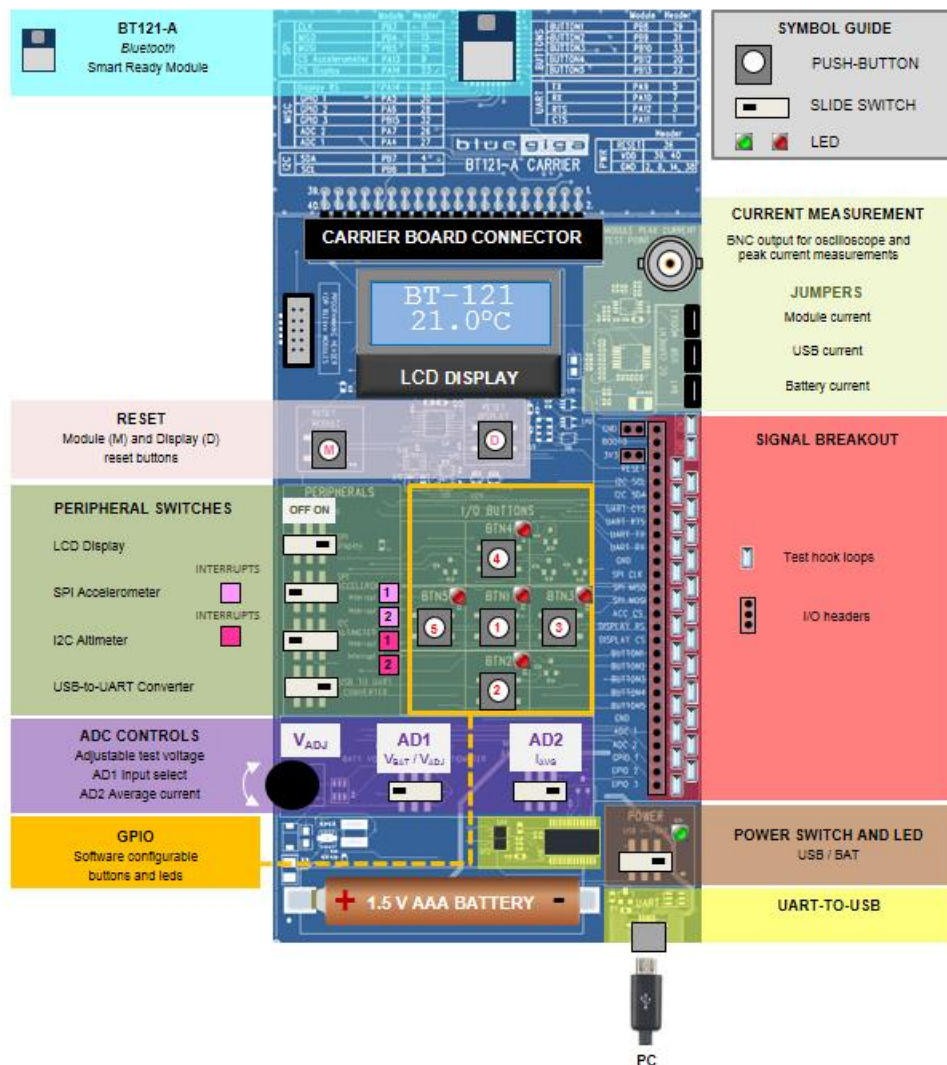

Figure 2: DKBT development kit overview

2.1 DKBT functional block diagram

The DKBT functional block diagram with essential components and interconnections is shown in [Figure 3](#) below.

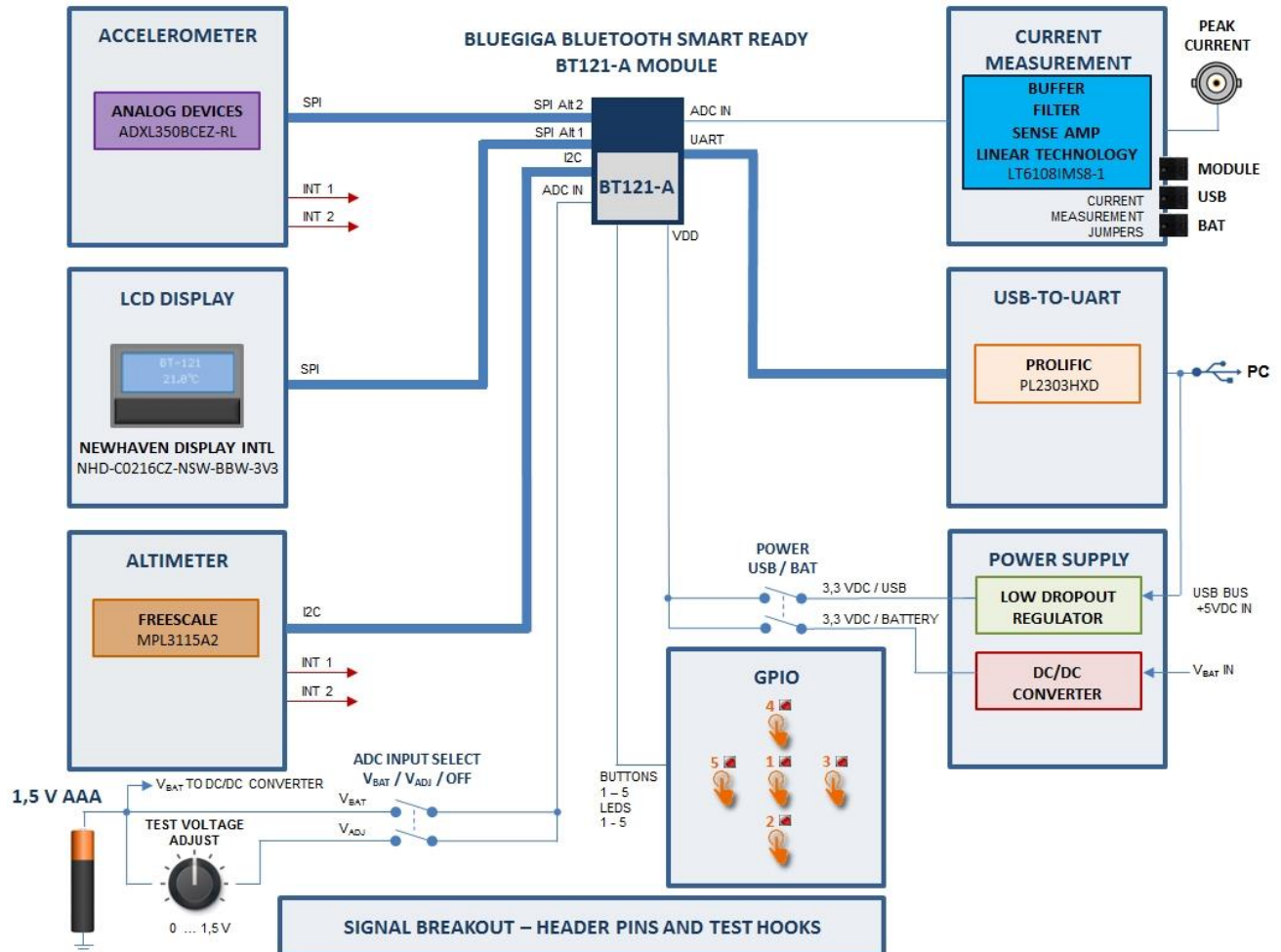

Figure 3: DKBT functional block diagram

BT121 Bluetooth Smarty Ready module provides various serial interfaces (SPI, I²C, UART) for connecting to peripherals and/or for communicating with other devices such as host processors. The SPI bus (Alt 1 and Alt 2) on the DKBT is connected to an accelerometer and to an LCD display while the I²C bus on the DKBT is connected to a precision altimeter/pressure sensor. The accelerometer and altimeter/pressure sensor both have two interrupt outputs, which are exposed as pads on the DKBT main board.

The DKBT main board contains also five push-buttons and five LEDs which can be controlled by GPIO of the BT121. Depending on how the firmware defines the corresponding GPIO pin on the BT121 module, the switches may be used as inputs. In such cases the corresponding LED will turn ON when the push-button is pressed down. If the pin has been configured as an output the LED acts as a visual indicator of the output state of that particular GPIO pin. LED's are buffered by a transistor to prevent loading of the GPIO pins of the module.

Current measurement circuitry offers the means to measure the peak and average current consumption of the module or of the whole DKBT board. A BNC connector driven by a fast buffer amplifier enables peak current measurements with the help of an oscilloscope

The UART of the BT121 is connected through a USB-TO-UART converter to a USB connector which provides easy connectivity to a PC.

3 Interpreting the silk screens

DKBT board and the BT121 carrier board have silk screens indicating relevant signals, components, switches, buttons etc. The carrier board silk screen contains signal tables which indicate the name of the signal as used on the DKBT main board, the actual BT121 module pad name and the DKBT header connector pin number. An example demonstrating the use of the silk screen information is shown below in

Figure 4.

Note that on the carrier board signal tables **Module Pad Name is actually designated as **Module Pin No.****

BT121-A MODULE PIN-OUT AND PAD NAMES

BT121-A TOP VIEW

SILK SCREEN GUIDE

EXAMPLE PROBLEM

Locate **UART CTS** signal on BT121 module, DKBT header connector, DKBT main board breakout header and on test hook loops.

SOLUTION

STEP 1
Locate appropriate function table on BT121 carrier board.

STEP 2
Locate desired function in **Function in DKBT** column.

STEP 3
Read corresponding BT121 PIO name from **Module Pin No.** column

STEP 4
Read corresponding DKBT HEADER connector pin number from **Header Pin No.** column

STEP 5
Locate pin number on DKBT HEADER connector.

STEP 6
Locate associated pin on BREAKOUT HEADER connector on DKBT main board.

STEP 7
Locate associated test hook on TEST HOOK LOOPS on DKBT main board.

FUNCTION TABLES

STEP 1

SPI	BUTTONS
MISC	UART
I2C	POWER

STEP 2

	Function in DKBT	Module Pin No.	Header Pin No.
UART	TX	PA9	5
	RX	PA10	7
	RTS	PA12	3
	CTS	PA11	1

STEP 3

BREAKOUT HEADER

GND	GND
3V3	BOOT0
	GND
	RESET
	I2C SDA
	UART CTS
	UART RTS
	UART TX
	UART RX
	GND
	SPI CLK
	SPI MISO
	SPI MOSI
	ACC CS
	DISPLAY RS
	DISPLAY CS
	BUTTON 1
	BUTTON 2
	BUTTON 3
	BUTTON 4
	BUTTON 5
	GND
	POT/VBAT
	AVG CURRENT
	0 mA REF
	GPIO 1
	GPIO 2

STEP 4

TEST HOOK LOOPS

GND	GND
	GND
	I2C SCL
	UART CTS
	UART TX
	GND
	SPI MISO
	ACC CS
	DISPLAY CS
	BUTTON 2
	BUTTON 4
	GND
	AVG CURRENT
	GPIO 1

STEP 5

DKBT HEADER FRONTAL SIDE VIEW

Figure 4: DKBT silk screen usage example.

4 Power supply options

DKBT development kit can be powered by three methods: by using a 1.5V AAA battery, through a USB connection or by using an external power supply connected to the 3V3 / GND header pins. Operation of the DKBT is identical regardless of the power supply option used.

4.1 Powering with a 1.5V AAA battery

- Install a 1.5 V AAA battery into the battery holder on DKBT noting the correct polarity as marked on the battery holder.
- Set the **POWER SWITCH** to position **BAT**.
- The green **POWER LED** near the **POWER SWITCH** should turn on indicating that power is fed to DKBT. See [Figure 5](#) on next page.

4.2 Powering through USB

- Connect a micro USB cable to the USB connected labeled **UART** and connect it to a PC or USB power supply.
- Set the **POWER SWITCH** to position **USB**.
- The green **POWER LED** near the **POWER SWITCH** should turn on indicating that power is fed to DKBT. See [Figure 5](#) on next page.

4.3 Powering using an external power supply

- Prepare an external power supply by adjusting the output voltage to 3.3 VDC. If the power supply has adjustable current limit set the current limit to a minimum level of 150 mA to allow normal operation without current limit.
- Absolute input voltage range is 2.2 - 3.6 VDC or 2.4 - 3.6 VDC when using the internal ADC or DAC of BT121.
- Attach the positive output of the external power supply to the 3V3 header and the negative output to the GND header on the DKBT main board.
- **POWER SWITCH** may be in either position.
- The green **POWER LED** near the **POWER SWITCH** should turn on indicating that power is fed to DKBT. See [Figure 5](#) on next page.



When using the internal ADC or DAC on the BT121 the voltage range is 2.4 - 3.6V.

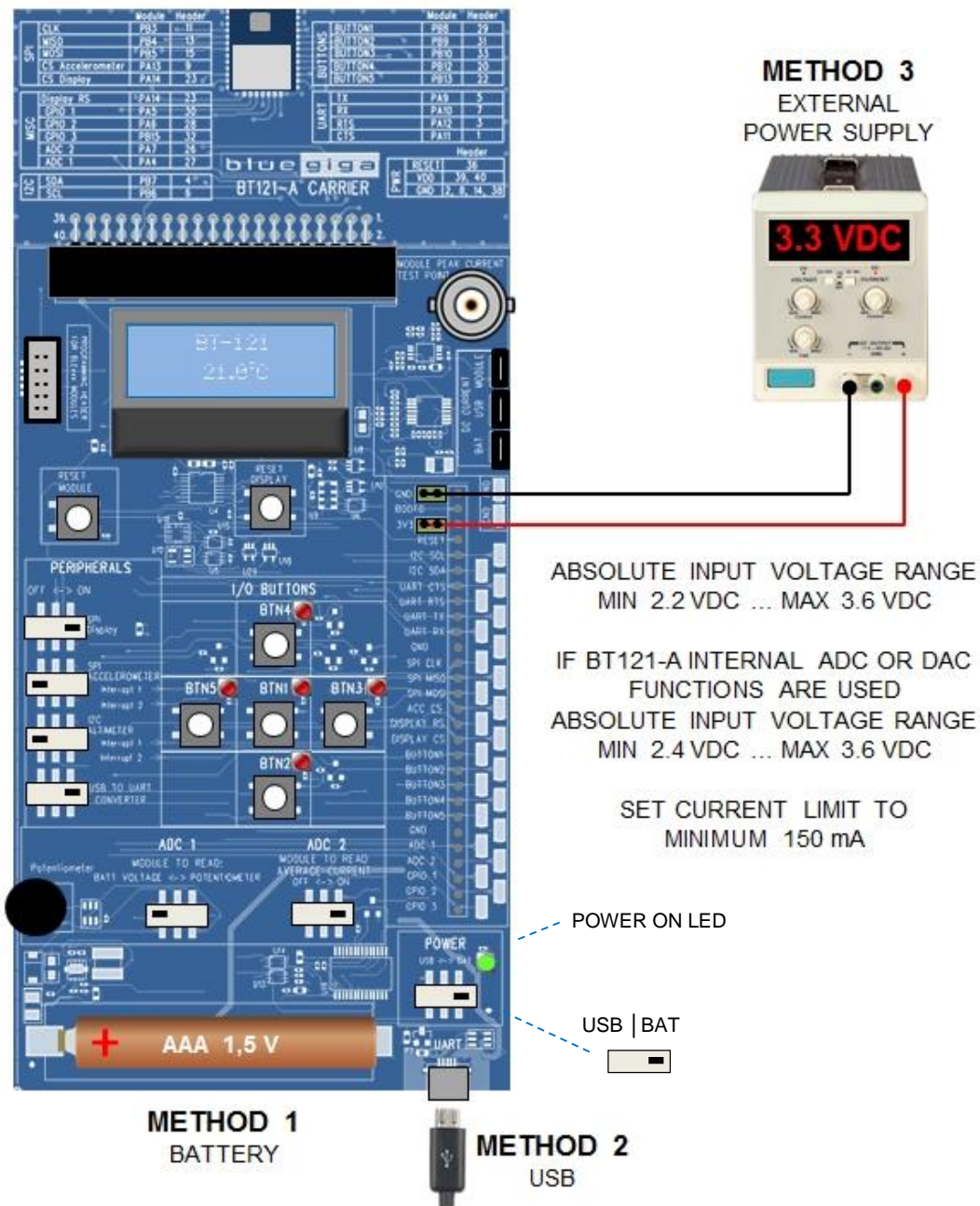

Figure 5: DKBT power supply options

5 Measuring the current consumption

DKBT development kit includes circuitry, headers and a BNC connector to enable convenient average and peak current measurements independent from the power supply. You can measure the current consumption of the whole board or just the current consumed by the Bluetooth module.

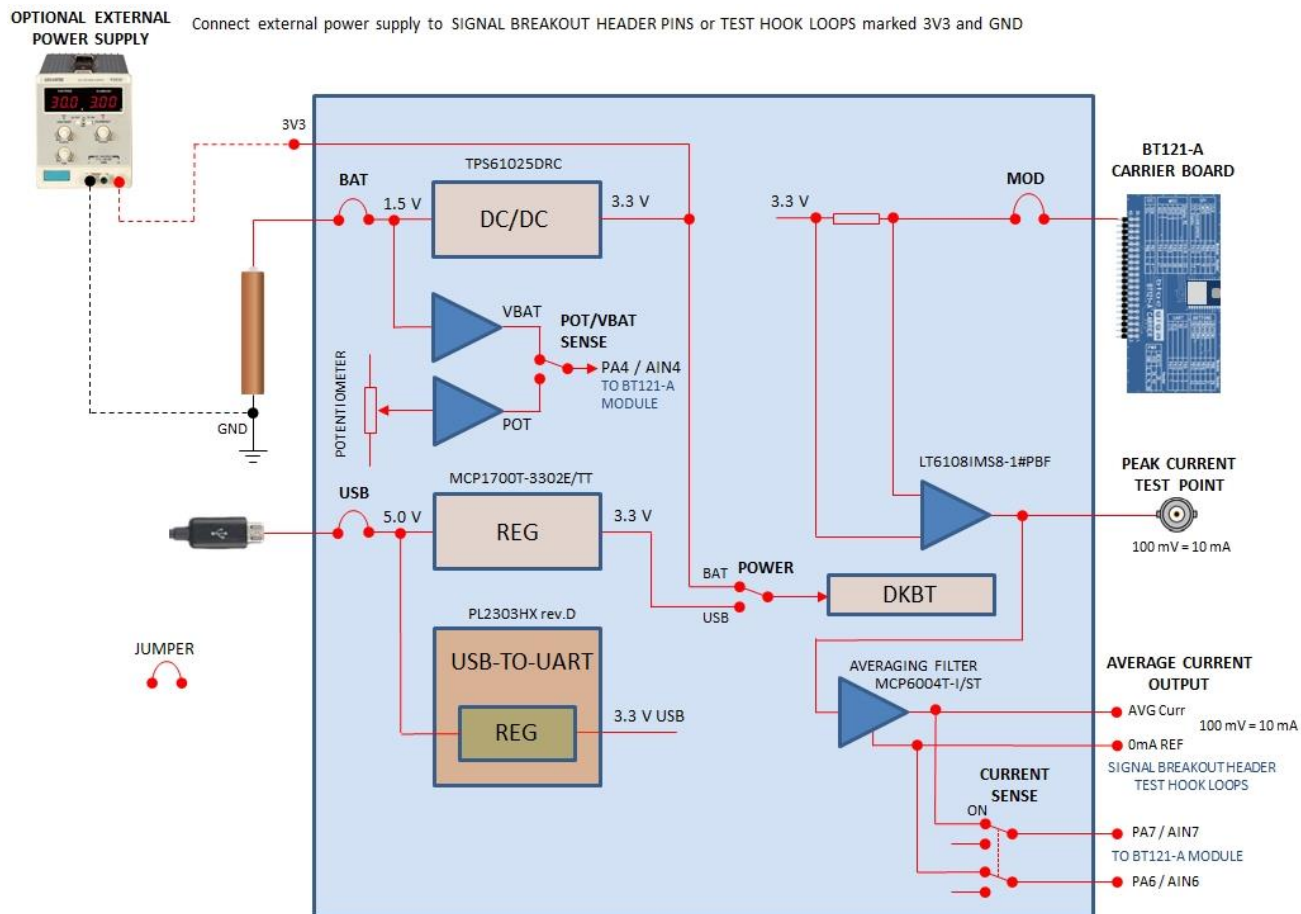

Figure 6: Current measurement circuitry and options on DKBT

One way to measure the current consumption is to use one of the following current measurement headers:

1. **BAT** header can be used to measure DKBT total current consumption when it's powered with a battery or external power supply. This test point provides an unfiltered, un-averaged current value (see NOTE 1 below).
2. **USB** header can be used to measure the DKBT total current consumption when it's powered through a USB connector. This test point provides an unfiltered, un-averaged current value (see NOTE 1 below).
3. **MOD** header can be used to measure the BT121 module's current consumption no matter which power supply is used. This test point provides an unfiltered, un-averaged current value (see NOTE 1 below).

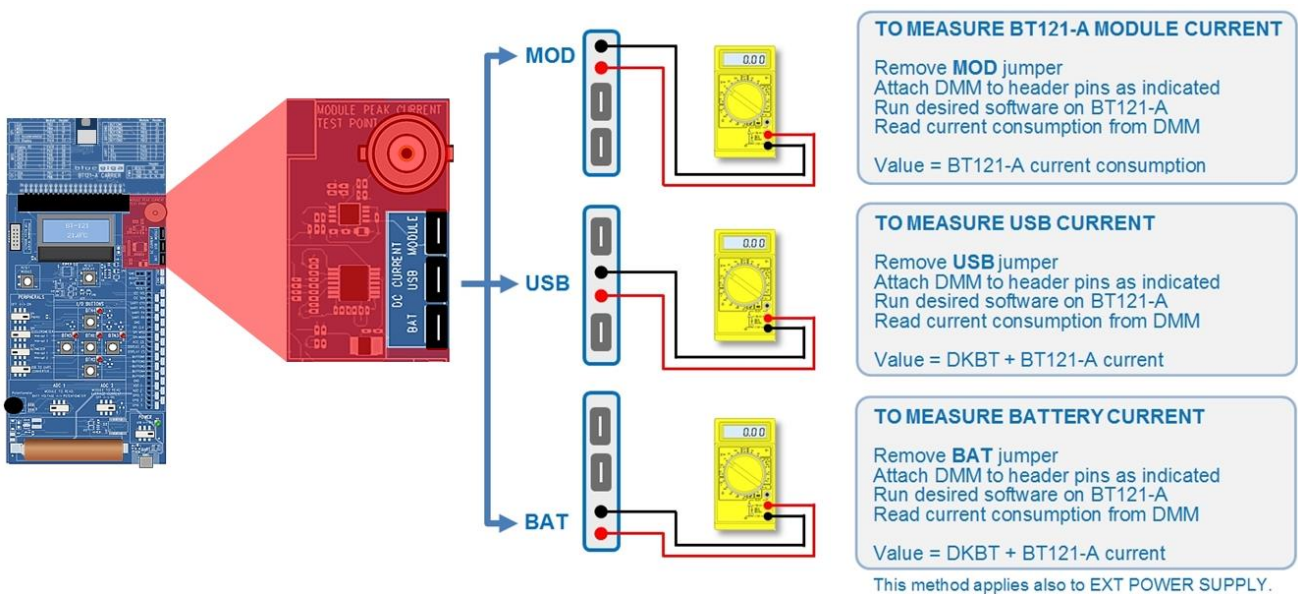

Figure 7 Current consumption measurement using MOD, USB and BAT headers



Note 1: The DMM must be in current measurement mode (DC only).

Other current measurement options are also included on the DKBT development kit:

- **PEAK CURR TEST POINT** is a BNC connector for connecting the DKBT BT121 module power supply line to an oscilloscope for peak current measurements. This test point provides an unfiltered, un-averaged current value converted to voltage (100 mV = 10 mA).
- **AVG CURR** provides the same output as the PEAK CURR TEST POINT the difference being that the output is filtered to provide an average current consumption value. Measurement is made with DMM in voltage measurement mode connected to AVG CURR and 0 mA REF header pins. These two header pins provide a filtered, averaged current value converted to voltage (100 mV = 10 mA).
- **0mA REF** provides the zero reference for AVG CURR test point. See description above.

5.1 Measuring average currents with a DMM

The current which can be measured through the header connections is not filtered or averaged in any way. Some current peaks during Bluetooth TX/RX operations are very short and require a high quality DMM to be used. To make the average current measurement easier the DKBT main board has built-in current averaging circuitry measuring the current flowing into the BT121's power supply line. The voltage outputs of this circuitry are available on the DKBT pin header and are named as **0 mA REF** and **AVG CURR**.

To measure the average current consumption connect a DMM in voltage measurement mode to **0 mA REF** and **AVG CURR** header pins. The output is scaled: 100 mV / 10 mA.

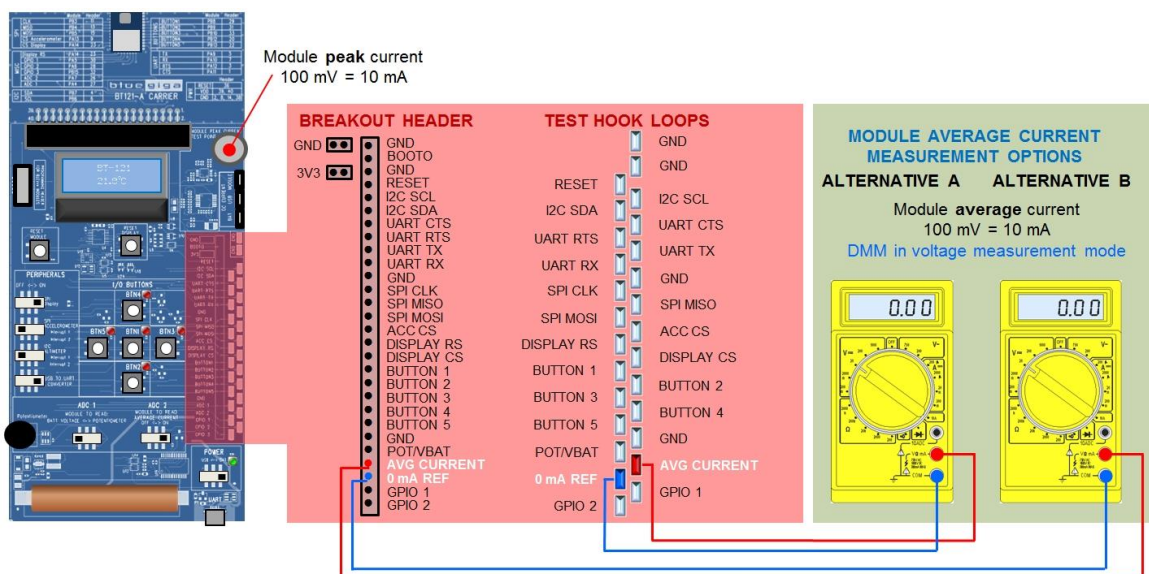

Figure 8: Average current measurement

5.2 Measuring sleep currents with a DMM

Sleep current consumption of BT121 is typically in the range of microamps which means that it is important to use measuring equipment which does not cause excessive errors caused by burden voltage. For most accurate current measurements with a DMM an external precision current adapter (e.g. μ Current Gold by EEVBLOG or similar) is needed to remove the effect of burden voltage caused by the shunt resistor in the current measurement circuitry (see Figure 9 below). Such adapters may also improve the dynamical response of the measurement setup drastically.

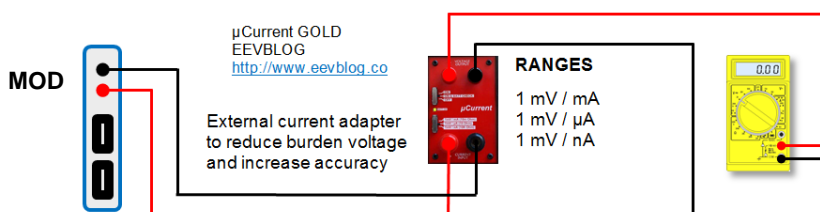

Figure 9: Using an external precision current adapter to minimize burden voltage effects in low current measurements.

5.3 Measuring peak currents with an oscilloscope

A typical DMM cannot be used to measure the peak current consumption, since the current peaks are typically too short to be reliably detected. Also current peaks can be too low to be reliably detected with a DMM.

For measuring the peak currents there is a BNC connector on the DKBT main board, which can be used to directly connect to a digital oscilloscope. The BNC connector output on the DKBT marked PEAK CURRENT TEST POINT (see Figure 10 on next page) provides the module current buffered by a Linear Technology LT6108 (High Side Current Sense Amplifier with Reference and Comparator) and is configured to produce an output of 100 mV / 10 mA.

To measure the peak TX current consumption of the module, connect a coaxial cable to the BNC connector in DKBT and to the oscilloscope input. Then run the desired software in the BT121.

Basic recommended settings for the oscilloscope:

- Coupling: DC
- Vertical scale: 200 mV/DIV
- Horizontal scale: 500 μ s/DIV
- Level: 400 mV
- Offset: 0.0 V
- Trigger: Normal, rising edge

As stated above, the output on the display corresponds to 100 mV / 10 mA.

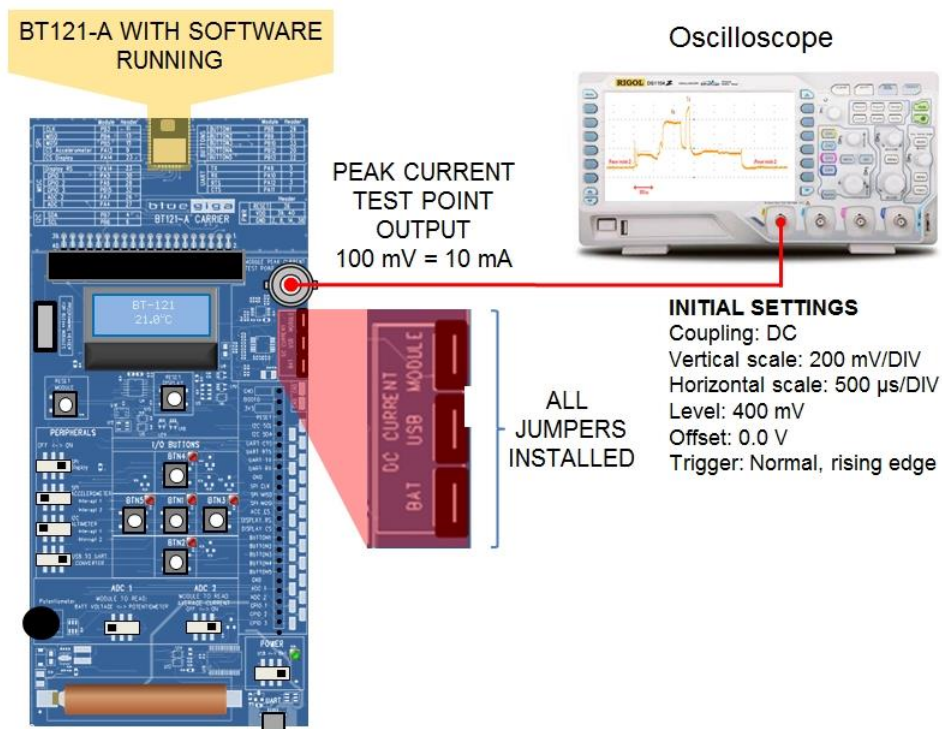

Figure 10: Peak current measurement using an oscilloscope.

6 Peripherals

DKBT board includes peripherals sensors which can be used in different demo applications or software prototypes. Additional peripherals and devices can of course be connected to the DKBT via the pin header on the main board.

Details of the available peripherals including interface pins used with BT121 are listed in [Table 1](#) below.

Peripheral	Interface	Manufacturer / Type	Function
LCD Display	SPI 1 Alt 2 PB3: SCK PB4: MISO PB5: MOSI PA14: CS PB14: Display RS	Newhaven Display Intl NHD-C0216CZ-NSW-BBW-3V3	Display
Accelerometer	SPI 1 Alt 1 PA13: CS PB5: MOSI PA13: CS ACC combined with OR-gate (U12 in DKBT) to form SDA/SDI/SDIO signal for sensor	Analog Devices ADXL350BCEZ-RL	Acceleration
Altimeter	I2C 1 Alt 1 PB6: SCL PB7: SCA	Freescale MPL3115A2	Altitude Pressure Temperature
USB-to-UART Converter	UART PA9: TX PA10: RX PA11: CTS PA12: RTS	Prolific PL2303HX Rev. D	Bus converter
Button 1 Button 2 Button 3 Button 4 Button 5	PB8 PB9 PB10 PB12 PB13	-	Manual input
LED 1 LED 2 LED 3 LED 4 LED 5	PB8 PB9 PB10 PB12 PB13	-	Visual indicator
Potentiometer	AIN4 PA4	-	ADC test voltage adjust
0 mA reference	AIN6 PA6	-	Current measurement reference Module average current output
Current sense	AIN7 PA7	-	Current output to ADC Module average current output

Table 1: DKBT peripherals



Individual peripheral switches determine only whether the SPI (or I²C) bus of the related peripheral is connected or disconnected from the common SPI (or I²C) bus of DKBT. Power supply input to the peripheral is not affected. Switch positions do not have an impact on current consumption.



With all slide-switches OFF BT121 acts completely in stand-alone mode. All I/O signals and busses are available on the BREAKOUT HEADER connectors and on the TEST HOOK LOOPS.

6.1 Buttons and LEDs

There are five push-buttons and five red LED indicators which turn on when the related button is pressed. These LEDs may also be controlled via the BT121 GPIO pins when the appropriate pins are programmed to work as outputs.

6.2 Potentiometer

A trimmer potentiometer can be used to adjust an analog test voltage connected to the internal AD-converter of the BT121 through an electronic relay. Potentiometer can be enabled or disabled with POT/VBAT SENSE switch.

The POT/VBAT SENSE switch has three positions

OFF = No output to BT121 internal AD input

BAT VOLTAGE = Battery voltage connected to BT121 internal AD input channel AIN4 (PA4)

POT = Potentiometer voltage connected to BT121 internal AD input channel AIN4 (PA4)

6.3 Current sense and 0mA reference

With this feature one of the AD input channels (AIN7 / PA7) on the BT121 can be used to measure the average current consumption of the module itself.

This feature is controlled using the CURRENT SENSE switch, which has two positions:

OFF = No output to BT121 internal AD input

ON = Average current output (100 mV / 10 mA) voltage is connected to AD input channel AIN 7 / PA7) on BT121.

The feature can be enabled/disabled CURRENT SENSE switch.

6.4 LCD display

The LCD display in DKBT is a Newhaven Display International 2 lines x 16 characters backlit display and uses 5 x 8 with cursor character set. The display has a 4-line serial interface (SPI bus) which is used for controlling the display and for sending characters to be displayed.

The connection schematics between the LCD display and BT121 module are shown below in [Figure 11](#) below.

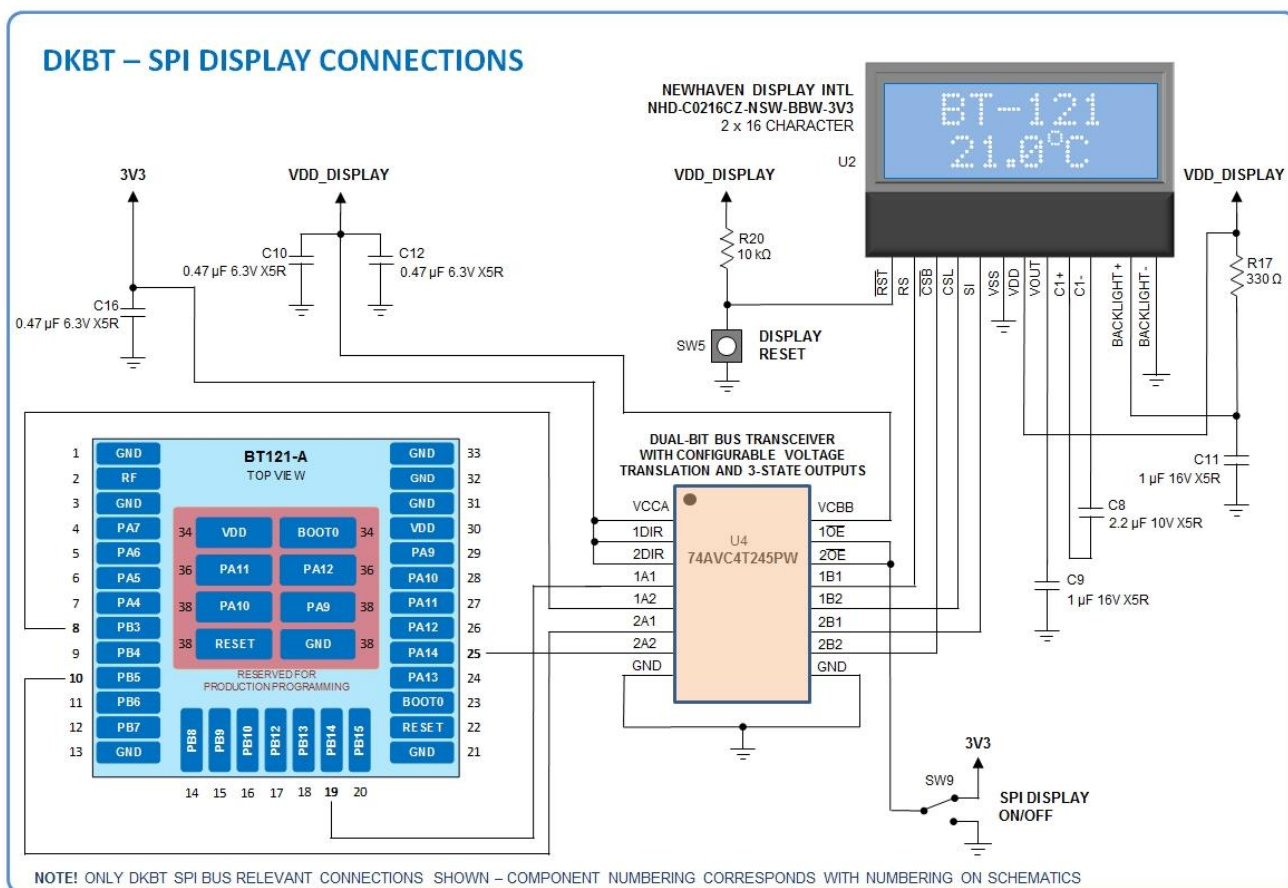

Figure 11: SPI display connections to BT121 in DKBT



The dual-bit bus transceiver (74AVC4T245PW) shown in the schematics is needed only if physical isolation is required. If the end-application firmware manages chip selection and alternating between the use of the interfaces there is no need for the 74AVC4T245PW type of solution. The purpose of the 74AVC4T245PW in DKBT is to allow isolating the LCD display from the SPI bus completely if needed.



The manual RESET button could be replaced by connecting the LCD display RST signal to a GPIO pin of the BT121. If the power supply used has enough current capability VDD_DISPLAY could be connected directly to the power supply which feeds the BT121.

6.5 SPI accelerometer

The accelerometer in DKBT is the Analog Devices ADXL350BCEZ-RL 3-axis accelerometer with 13-bit resolution and selectable ranges with maximum g force at ± 8 g. It also features free fall, tap and double tap as well activity and inactivity detection. The digital output data is formatted as 16-bit two's complement and is accessible through SPI interface.

The accelerometers interrupt pins are separately available on the DKBT main board.

The connection schematics between the accelerometer sensor and BT121 module is shown below in [Figure 12](#).

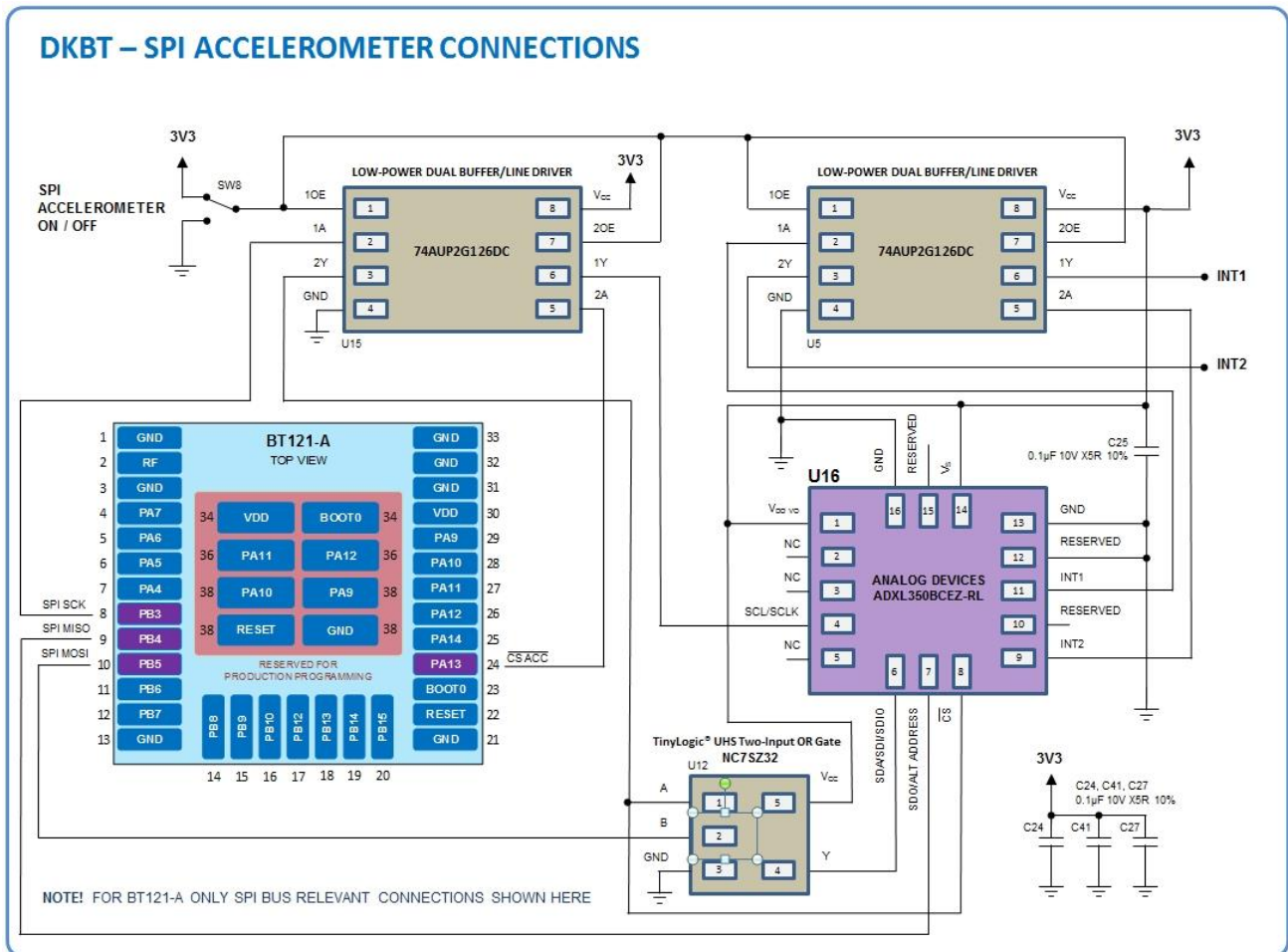

Figure 12: SPI Accelerometer connections to BT121 in DKBT



The Low-Power Dual Buffer/Line Drivers (74AUP2G126DC) shown in the schematics are needed only if the end-application has several SPI bus devices connected to BT121. The purpose of the 74AUP2G126DC's in DKBT is to allow isolating the accelerometer sensor from the SPI bus completely when needed.



The TinyLogic® UHS Two-Input OR Gate NCSZ32 is used to form the SDIO signal for the accelerometer sensor from BT121 SPI MOSI output and CS ACC signals.

6.6 I²C altimeter

The altimeter in DKBT is the Freescale MPL3115A2 which provides very accurate pressure and altitude data. It has digital output, two interrupts for auto-wake, minimum/maximum threshold detection and autonomous data acquisition.

The altimeters interrupt pins are separately available on the DKBT main board.

The connection schematics between the accelerometer chip and BT121 module is shown below in [Figure 13](#). Connection to BT121 is very simple and requires only the use of two NXP analog switches (Low-ohmic single-pole single-throw analog switch NX3V1G384GW) to isolate the SCL and SDA signal lines when required.

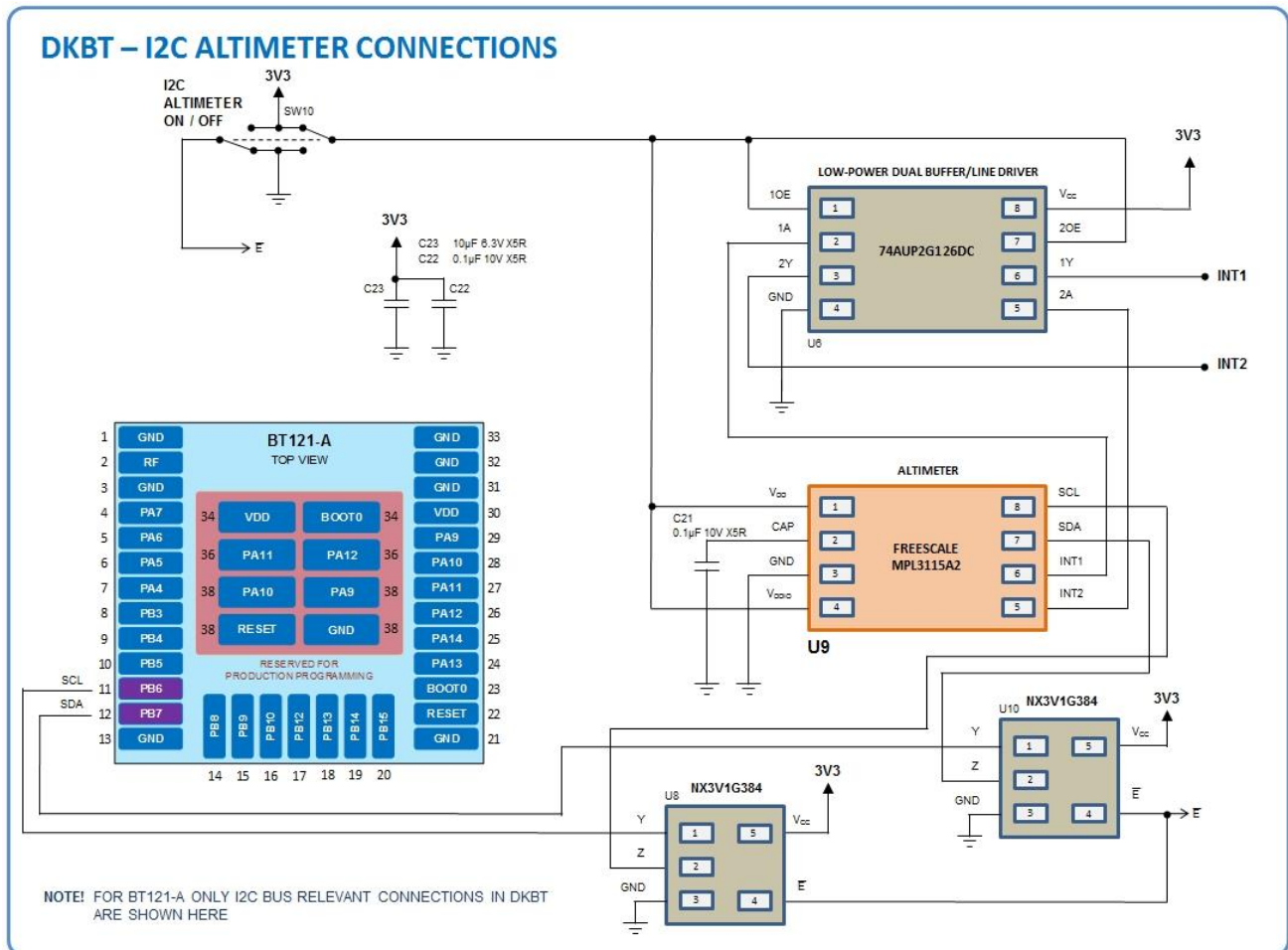

Figure 13: I²C Altimeter connections to BT121 in DKBT



The two NXP analog switches shown in the schematics needed if the end-application has more than one SPI device connected to the same SPI interface on the BT121 and if the firmware does not manage chip selection to prevent bus contention issues.

7 Related documentation

The following documents contain relevant and/or useful information and is recommended reading for anyone developing applications for the BT121 module.

- **BT121 Data Sheet**

More details about the BT121 Bluetooth Smart Ready module hardware can be found from the data sheet.

- **DKBT Development Kit design materials**

DKBT development kit design materials (schematics, PCB drawing, BoM) are available for download and can be used as a reference design.

- **Bluetooth Smart Software Getting Started Guide**

The Bluetooth Smart software getting started guide explains the architecture of the Bluetooth stack software, the available APIs and development options and also contains a brief introduction to the PC tools and the software development flow.

8 Contact information

Sales: www.bluegiga.com

Technical Support: www.bluegiga.com/support

Orders: bluegiga-orders@silabs.com

WWW: www.bluegiga.com

SILICON LABS

Phone: +1 877.444.3032
400 West Cesar Chavez
Austin, TX 78701 USA

FINLAND OFFICE

Phone: +358 9 435 5060
Fax: +358 9 435 50660
Sinikalliontie 5A, 5th floor
02630 Espoo, Finland