

**Fire Door Hold Open Magnets – AEM19001 & AEM19002**



AEM19001



*The new Fire Door Hold Open Magnets are designed for holding open doors in a public area, and released where the doors are closed in the event of fire detection.*

The Magnets are ideal units for swing fire doors. Both units are designed with heavy duty steel construction making the units suitable for swing door systems in most environments.



AEM19002



**Features & Benefits**

- Surface mounts to standard BS wiring boxes
- Holding force 55kg
- Heavy duty steel construction
- Fitted with an integral release button
- Units are supplied with armature plate
- Units can be used in conjunction with any suitable fire alarm system
- Residual anti-magnetism pin on the electromagnet body
- Operating voltage: 24 vdc
- Absorbed current: 70 mA
- Nickel plated magnetic block
- Wall Mounted units
- Connector with anti-disturb varistor
- AEM19001 body is in black ABS with galvanized steel base
- AEM19002 body is in anodized aluminium with galvanized steel base

Product Code	
AEM19001	Fire Door Hold Open Magnet 24vdc Plastic
AEM19002	Fire Door Hold Open Magnet 24vdc Anodized Aluminium

### Fire Door Hold Open Magnets – AEM19001 & AEM19002

#### Technical Drawing

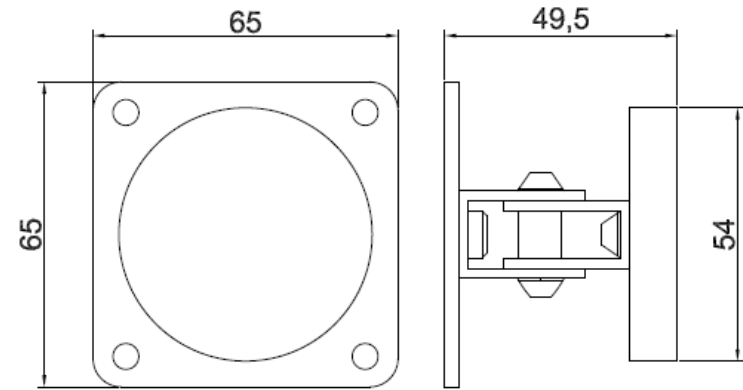
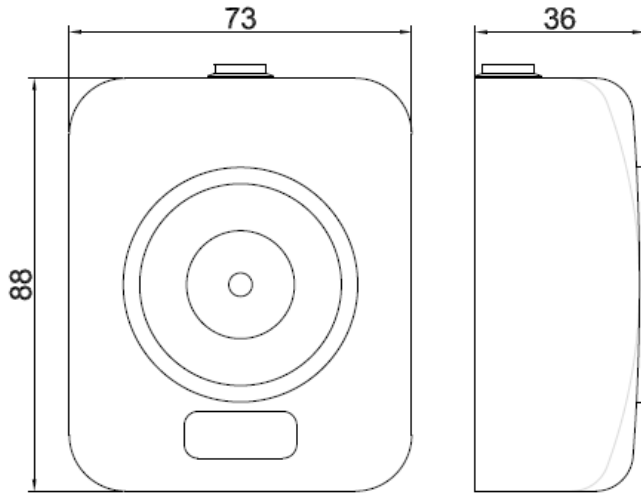

#### Certification

CEN Standard	Classification Code					
EN 1155:2003	3	8	3	1	1	3
			7			

For further information contact:

Securefast plc  
 Unit 6 & 7  
 The Cedars Business Centre  
 Avon Road, Cannock  
 Staffordshire  
 WS11 1QJ



Call > +44 (0) 1704 502801

Email > sales@securefast.co.uk

Visit > www.securefast.co.uk