

Keysight 16334A Test Fixture



Operation and
Service Manual

NOTICE: This document contains references to Agilent Technologies. Agilent's former Test and Measurement business has become Keysight Technologies. For more information, go to www.keysight.com.



Notices

The information contained in this document is subject to change without notice.

This document contains proprietary information that is protected by copyright. All rights are reserved. No part of this document may be photocopied, reproduced, or translated to another language without the prior written consent of the Keysight Technologies.

© Copyright 1990 - 2014 Keysight Technologies

Manual Printing History

The manual's printing date and part number indicate its current edition. The printing date changes when a new edition is printed. (Minor corrections and updates that are incorporated at reprint do not cause the date to change.) The manual part number changes when extensive technical changes are incorporated.

January 1990	First Edition (part number: 16334-90000)
December 1999	Second Edition (part number: 16334-90000)
September 2008	Third Edition (part number: 16334-90010)
November 2014	Fourth Edition (part number: 16334-90010)

Safety Summary

The following general safety precautions must be observed during all phases of operation, service, and repair of this instrument. Failure to comply with these precautions or with specific WARNINGS elsewhere in this manual may impair the protection provided by the equipment. In addition it violates safety standards of design, manufacture, and intended use of the instrument.

The Keysight Technologies assumes no liability for the customer's failure to comply with these requirements.

- **Ground The Instrument**

To avoid electric shock hazard, the instrument chassis and cabinet must be connected to a safety earth ground by the supplied power cable with earth blade.
- **DO NOT Operate In An Explosive Atmosphere**

Do not operate the instrument in the presence of flammable gasses or fumes. Operation of any electrical instrument in such an environment constitutes a definite safety hazard.
- **Keep Away From Live Circuits**

Operating personnel must not remove instrument covers. Component replacement and internal adjustments must be made by qualified maintenance personnel. Do not replace

components with the power cable connected. Under certain conditions, dangerous voltages may exist even with the power cable removed. To avoid injuries, always disconnect power and discharge circuits before touching them.

- **DO NOT Service Or Adjust Alone**

Do not attempt internal service or adjustment unless another person, capable of rendering first aid and resuscitation, is present.

- **DO NOT Substitute Parts Or Modify Instrument**

Because of the danger of introducing additional hazards, do not install substitute parts or perform unauthorized modifications to the instrument. Return the instrument to a Keysight Technologies Sales and Service Office for service and repair to ensure that safety features are maintained.

- **Dangerous Procedure Warnings**

Warnings, such as the example below, precede potentially dangerous procedures throughout this manual. Instructions contained in the warnings must be followed.

WARNING

Dangerous voltages, capable of causing death, are presenting this instrument. Use extreme caution when handling, testing, and adjusting this instrument.

Safety Symbol

General definitions of safety symbols used on the instrument or in manuals are listed below.



Instruction Manual symbol: the product is marked with this symbol when it is necessary for the user to refer to the instrument manual.



Alternating current.



Direct current.



On (Supply).



Off (Supply).



In position of push-button switch.



Out position of push-button switch.



Frame (or chassis) terminal. A connection to the frame (chassis) of the equipment which normally include all exposed metal structure.

WARNING

This warning sign denotes a hazard. It calls attention to a procedure, practice, condition or the like, which, if not correctly performed or adhered to, could result in injury or death to personnel.

CAUTION

This Caution sign denotes a hazard. It calls attention to a procedure, practice, condition or the like, which, if not correctly performed or adhered to, could result in damage to or destruction of part or all of the product.

NOTE

Note denotes important information. It calls attention to a procedure, practice, condition or the like, which is essential to highlight.

Certification

Keysight Technologies certifies that this product met its published specifications at the time of shipment from the factory. Keysight Technologies further certifies that its calibration measurements are traceable to the United States National Institute of Standards and Technology, to the extent allowed by the Institution's calibration facility, or to the calibration facilities of other International Standards Organization members.

Warranty

This Keysight Technologies instrument product is warranted against defects in material and workmanship for a period corresponding to the individual warranty periods of its component products. Instruments are warranted for a period of one year. Fixtures and adapters are warranted for a period of 90 days. During the warranty period, Keysight Technologies will, at its option, either repair or replace products that prove to be defective.

For warranty service or repair, this product must be returned to a service facility designated by Keysight Technologies. Buyer shall prepay shipping charges to Keysight Technologies and Keysight Technologies shall pay shipping charges to return the product to Buyer. However, Buyer shall pay all shipping charges, duties, and taxes for products returned to Keysight Technologies from another country.

Keysight Technologies warrants that its software and firmware designated by Keysight Technologies for use with an instrument will execute its programming instruction when properly installed on that instrument. Keysight Technologies does not warrant that the operation of the instrument, or software, or firmware will be uninterrupted or error free.

Limitation of Warranty

The foregoing warranty shall not apply to defects resulting from improper or inadequate maintenance by Buyer, Buyer-supplied software or interfacing, unauthorized modification or misuse, operation outside the environmental specifications for the product, or improper site preparation or maintenance.

IMPORTANT

No other warranty is expressed or implied. Keysight Technologies specifically disclaims the implied warranties of merchantability and fitness for a particular purpose.

Exclusive Remedies

The remedies provided herein are buyer's sole and exclusive remedies. Keysight Technologies shall not be liable for any direct, indirect, special, incidental, or consequential damages, whether based on contract, tort, or any other legal theory.

Assistance

Product maintenance agreements and other customer assistance agreements are available for Keysight Technologies products.

For any assistance, contact your nearest Keysight Technologies Sales and Service Office. Addresses are provided at the back of this manual.

Typeface Conventions

Bold	Boldface type is used when a term is defined. For example: icons are symbols.
<i>Italic</i>	Italic type is used for emphasis and for titles of manuals and other publications.
[Hardkey]	Indicates a hardkey labeled "Hardkey."
Softkey	Indicates a softkey labeled "Softkey."
[Hardkey] - Softkey1 - Softkey2	Indicates keystrokes [Hardkey] - Softkey1 - Softkey2 .

1. Operation

- DESCRIPTION 10
- Specifications 12
- Typical Characteristics 13
- ZERO OFFSET ADJUSTMENT 14
- OPERATION 15

2. Service

- Maintenance 18

1 **Operation**

This operation note provides complete information on the 16334A Test Fixture.

DESCRIPTION

The 16334A Test Fixture is designed for use with the instruments, type of LCR/Impedance meter.

The latest applicable instruments for 16334A test fixture is described in the Accessories Selection Guide for Impedance Measurements of 5965-4792E.

The 16334A is a direct attachment, 4-terminal pair type fixture which is equipped with a tweezer type probe for measurement of leadless components such as chip capacitors.

The tweezer tips are replaceable. The distance between the tweezer tips is continuously adjustable according to the distance between the DUT terminals. A compensation block is furnished for compensation to be minimize the effects of residual impedance and the stray admittance.

The specifications of the 16334A are given in [Table 1-2](#), and the typical characteristics are shown in [Figure 1-2](#), and listed in [Table 1-3](#).

Figure 1-1

Product Overview

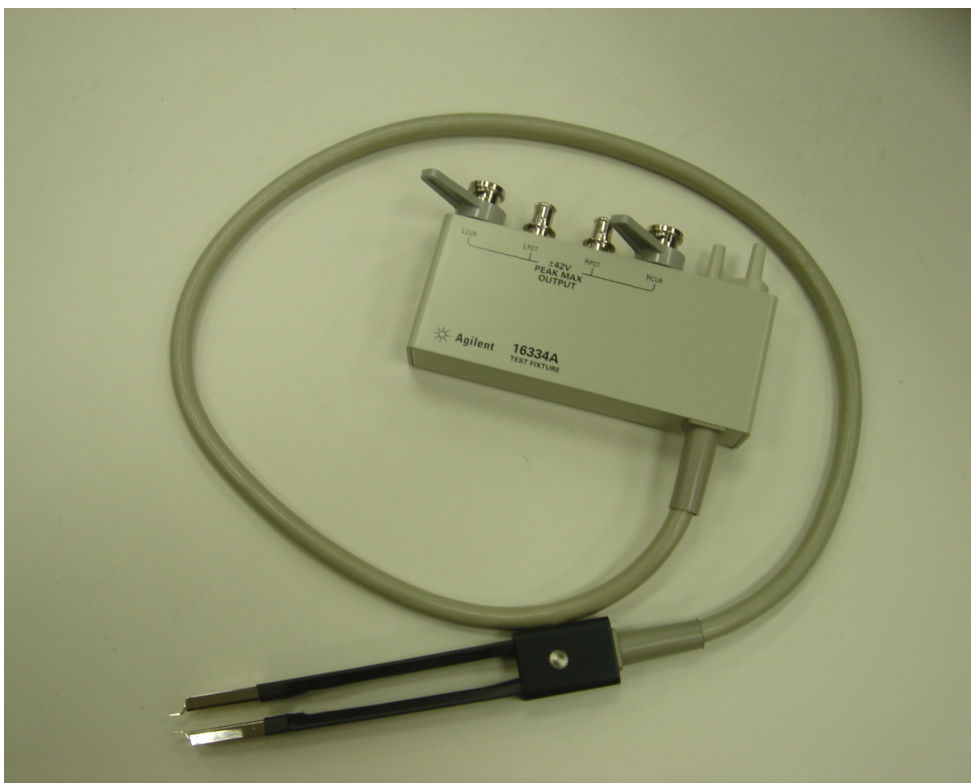

Table 1-1

Accessories

Description	Keysight Part No
Compensation Block	16334-60001
Tweezer Tip	16334•09002 (1ea.)

Figure 1-2

Accessories

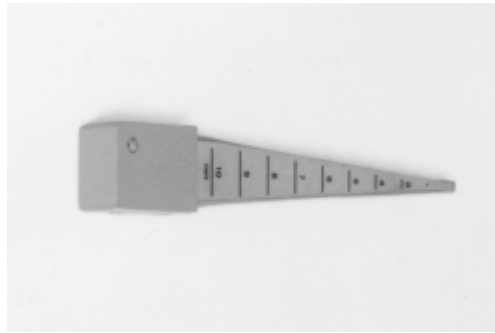

Specifications

Table 1-2

Function:	For use with 4 terminal-pair LCR Meters and Impedance Analyzers.
Measurable Components:	Miniature components with terminals on opposite faces (Distance between component terminals $\leq 10\text{mm}$).
Terminal Configuration:	4-terminal pair configuration from BNC connectors to the top of the tweezers (excluding the tweezer tips).
Cable Length:	Approximately 1m
Maximum Voltage:	$\pm 42\text{V}$ peak max. (AC+DC)
Measurement Frequency Range:	5 Hz to 15 MHz
Cable Length:	Approximately 1m (from BNC connector to the top of the tweezers)
Weight:	Approximately 0.29 kg

Typical Characteristics

Table 1-3 Typical Characteristics

Model	Applicable Measurement Range		Incremental error (1 MHz ≤ f)	
	Parameter Value	Measurement Frequency	Parameter reading error (%)	Offset value for D
4194A/E4990A	Full range	below 15 MHz	$\pm 2\infty(f/10)^2 \%$	$\pm 0.02\infty(f/10)^2$

NOTE f is the measurement frequency in MHz. The incremental error is available at the frequency range 1 MHz to 15 MHz, and incremental error applies after the completion of ZERO-OPEN/SHORT compensation.

Figure 1-3 Incremental Error

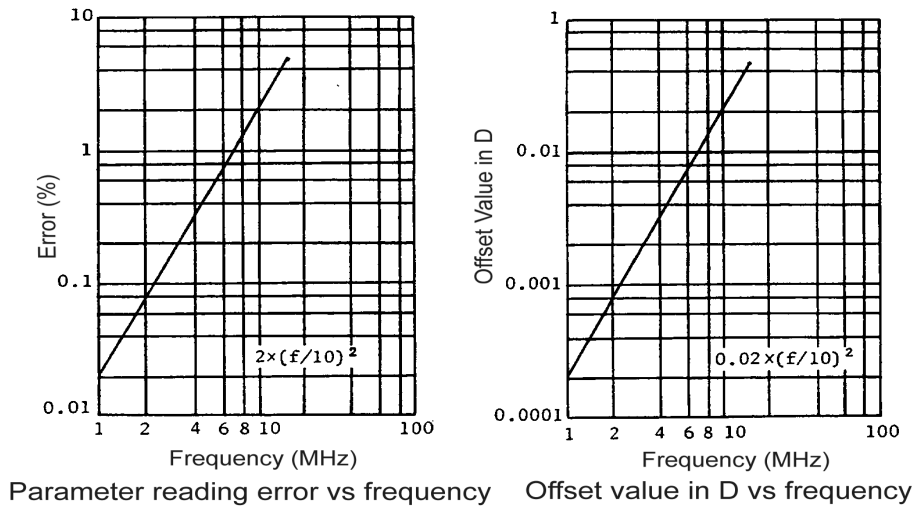

ZERO OFFSET ADJUSTMENT

The 16334A has inherent residual impedance and stray admittance that affects the accuracy of the measurements. To compensate for, or negate, these residuals in order to minimize measurement error, the instrument's zero offset adjustment procedure should be performed. The zero offset adjustment procedure is described in the instrument's manual. When performing the zero offset adjustment, use compensation block Keysight PN 16334-60001 (furnished with probe). An illustration showing how to use the compensation block is shown in [Figure 1-4](#).

Figure 1-4

Zero Offset Adjustment

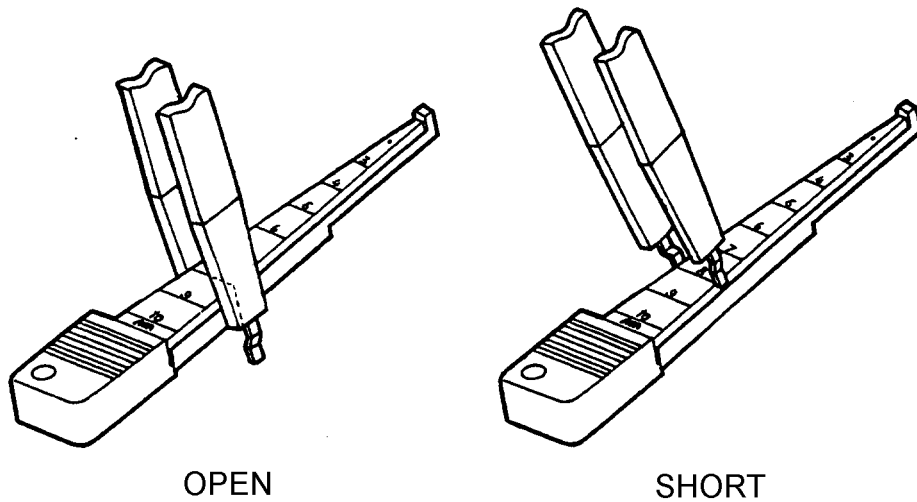

OPERATION

Setup and measurement procedure is as follows:

1. Set the instrument's cable LENGTH to 1m.
2. Connect the 16334A directly to the UNKNOWN terminals of the instrument.
3. Perform the ZERO offset adjustment described in the instrument's operation manual.
4. Connect the DUT to the 16334A test fixture.

WARNING

DO NOT APPLY MORE THAN $\pm 42\text{V}$ OF DC BIAS VOLTAGE TO THE UNKNOWN TERMINALS. AN ELECTRICAL SHOCK HAZARD WILL EXIST DURING OPERATION WHEN THE DC BIAS VOLTAGE IS GREATER THAN $\pm 42\text{V}$ DC.

Operation
OPERATION

2 **Service**

Maintenance

An exploded view of the 16334A (for parts identification) is shown in [Figure 2-1](#). Do not disassemble any further than shown. Maintenance consists principally of cleaning contacts and replacing worn or damaged parts. Take special care when cleaning contacts. To order parts, use the Keysight Technologies part numbers listed in [Table 2-1](#). If a faulty part is located in an assembly that cannot be disassembled, order the next higher assembly or return the whole device to the nearest Keysight Technologies Sales/Service Office for repair or replacement.

Figure 2-1 Parts Identification

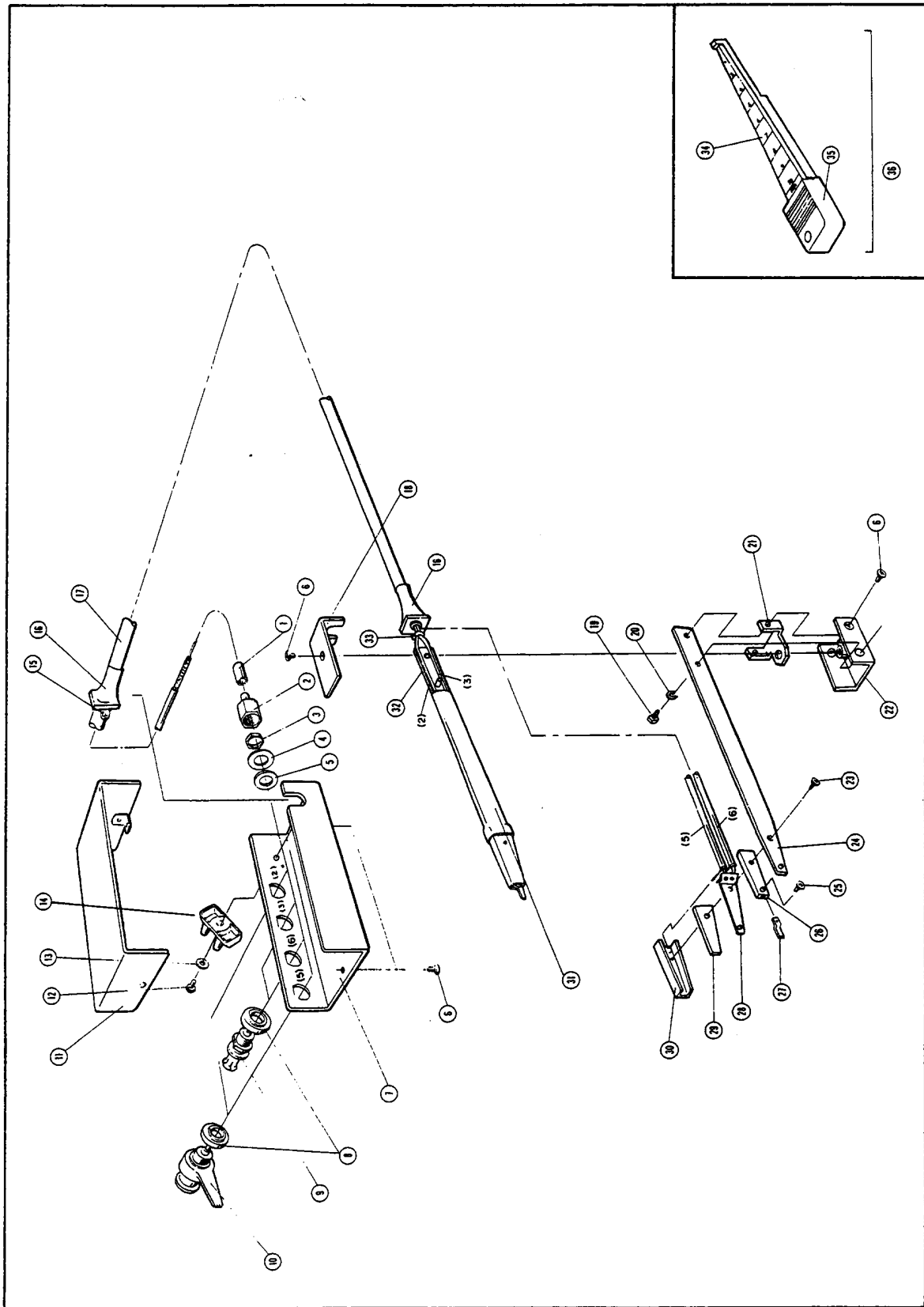

Service
Maintenance

Table 2-1

Parts Identification

Reference	Keysight Part No.	Qty.	Description	Note
1	*	4	SLEEVE-METAL	1
2	*	4	NUT	1
3	*	4	NUT	1
4	*	4	WASHER	1
5	*	4	WASHER	1
6	0515-0914	7	SCREW	1
7	*	1	COVER-BOTTOM	1
8	*	4	INSULATOR	1
9	*	2	CONNECTOR-BNC	1
10	*	2	BNC-ASSY	1
11	16334-04001	1	COVER-TOP	
12	0515-1550	1	SCREW	
13	2190-0206	1	WASHER	
14	16047-40000	1	STOPPER	
15	1400-0719	2	CABLE-TIE	
16	16334-40003	2	CABLE BUSHING	
17	*	105.5 cm	CABLE	1
18	16334-01202	1	ANGLE	
19	16334-24002	1	SCREW	
20	2190-0584	1	WASHER	
21	16334-01213	1	BRACKET	2
22	16334-01211	1	BRACKET	2
23	0515-1873	2	SCREW	
24	16334-00612	1	ARM PLATE (marked "L")	
25	0515-1872	2	MACHINE SCREW	
26	16334-40001	2	INSULATOR	
27	16334-09002	2	CONTACT (TWEEZER TIP)	
28	16334-09001	2	CONTACT	

Table 2-1 **Parts Identification**

Reference	Keysight Part No.	Qty.	Description	Note
29	16334-09003	2	SPACER	
30	16334-00601	2	SHIELD	
31	0890-0273	2x8.5cm	TUBE, HEAT SHRINKABLE	
32	16334-00613	1	ARM PLATE (marked "H")	
33	1400-0249	2	CABLE TIE	
1 thru 33	16334-60010	1	TEST FIXTURE	
34	16334-00604	1	PLATE	
35	16334-40002	1	BASE	
36	16334-60001	1	COMPENSATION BLOCK ASSY	
21 (OLD)	16334-01203	1	BRACKET	2
22 (OLD)	16334-01201	1	BRACKET	2

Note 1 : Not separately replaceable. Order 16334-60010.

Note 2: For old designed (one screw) part, order the (OLD) part.

Service
Maintenance

This information is subject to change without notice.

© Keysight Technologies 1990 - 2014

Edition 4, November 2014



16334-90010
www.keysight.com