

T-2³/₄ MINIATURE BAYONET BASE

HALOGEN LAMP

28V 11.5W

WAMCO PART NO.	ENVELOPE SIZE	BASE TYPE	RATING	FILAMENT SHAPE
WL-8GH007429-28	T-2 ³ / ₄	BA9s/13	28V 11.5W	CC-8

TEST VOLTS	CURRENT (A)			LIGHT OUTPUT (MSCP)			LIFE HRS
	MIN	NOM	MAX	MIN	NOM	MAX	
28V	.369	.410	.451	6.7	8.8	10.9	8,000

DIMENSIONAL CHARACTERISTICS

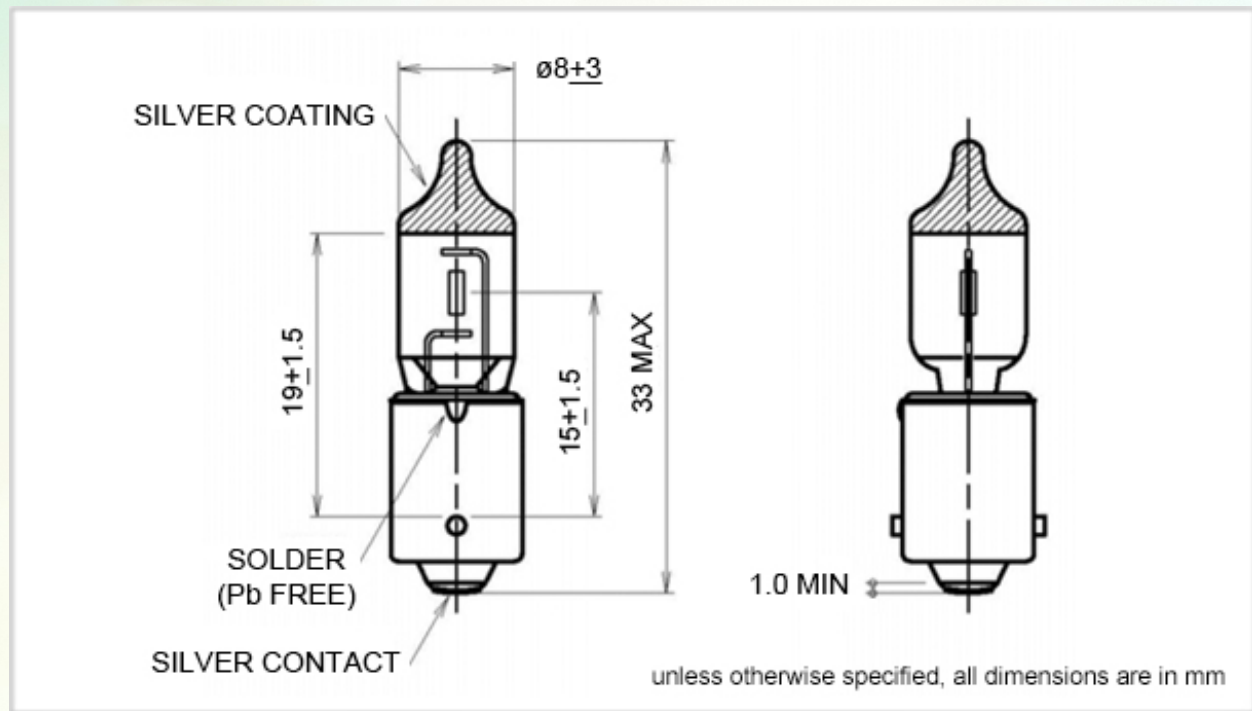

NOTES

1. Lamp clean with no foreign materials or glass chips inside
2. Envelope clear and free of scratches, discoloration, and any cement residue
3. Nickel-plated base
4. Primary contact silver-plated disk
5. Park mark WL-8GH007429-28
6. RoHS compliant

