

Definite Purpose Contactors and Starters

0–40A Compact Contactor



25–60A Starter



Heavy-Duty Special Purpose

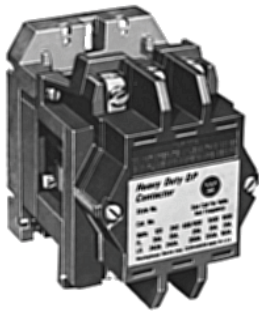

4.1 Product Overview—Contactors and Starters

| | |
|--------------------------------|---------|
| Product Overview | V5-T4-2 |
| Application Description | V5-T4-2 |
| Catalog Number Selection | V5-T4-3 |

4.2 Contactors

| | |
|--|----------|
| 20–40A, Compact Single- and Two-Pole—C25 | V5-T4-4 |
| 15–360A, Two-, Three- and Four-Pole—C25 | V5-T4-8 |
| Accessories | V5-T4-11 |
| 15–40A, Three-Pole Fuse Block | V5-T4-17 |
| 15–75A, Reversing and Two-Speed—C65 | V5-T4-20 |

4.3 Starters

| | |
|---|----------|
| 25–60A, Single- and Three-Phase—A25, B25 | V5-T4-23 |
| 15–45A, Single- and Three-Phase—A27, B27 | V5-T4-30 |
| 15–75A, Single- and Three-Phase—A30, B30 and C440/XT Electronic Overload Relay | V5-T4-38 |

4.4 NEMA Type 1 Enclosed Control

| | |
|---|----------|
| 15–60A Contactors—C25 | V5-T4-46 |
| 25–60A Starters—A25, B25 | V5-T4-49 |
| 15–45A Starters—A27, B27 | V5-T4-52 |
| Accessories | V5-T4-55 |
| Options | V5-T4-57 |
| Technical Data and Specifications | V5-T4-58 |

4.5 Renewal Parts

| | |
|---------------------------|----------|
| Product Selection | |
| Contact Kits, Coils | V5-T4-59 |

4.6 Heavy-Duty Special Purpose Contactors

| | |
|---|----------|
| Product Selection | V5-T4-64 |
| Accessories | V5-T4-64 |
| Renewal Parts | V5-T4-65 |
| Technical Data and Specifications | V5-T4-65 |
| Dimensions | V5-T4-66 |

4.7 Direct Current Contactors

| | |
|--------------------------------------|----------|
| Mill Type Contactors | V5-T4-67 |
| 600V Contactors | V5-T4-70 |
| DPM 750V Contactor | V5-T4-74 |
| AVD—Contactor | V5-T4-77 |
| D—Contactor | V5-T4-80 |
| Reversing/Assignment Contactor | V5-T4-83 |

4.8 Ratings

| | |
|----------------------------------|----------|
| Ampere Rating of AC Motors | V5-T4-86 |
|----------------------------------|----------|

Definite Purpose Contactors and Starters



4

Product Overview

Eaton offers the most complete line of Definite Purpose (DP) contactors in the industry. Designed for heating, ventilation, air conditioning and refrigeration (HVACR) applications, Eaton's DP contactors are designed to handle the most challenging installations.

Application Description

These ampere and horsepower rated devices from Eaton's Electrical Sector are designed for service in applications such as refrigeration, air conditioning and resistance heating and are manufactured to traditional standards for quality and reliability. They are subjected to stringent quality assurance inspections and testing procedures. The life expectancy, both electrical and mechanical, will meet or exceed industry performance requirements for Definite Purpose devices.

If more detailed technical information is required—specifications, ratings, and so on—contact your local Eaton distributor or sales office.

Contents

Description

Page

Contactors

| | |
|--|-----------------|
| 20–40A, Compact Single- and Two-Pole—C25 | V5-T4-4 |
| 15–360A, Two-, Three- and Four-Pole—C25 ... | V5-T4-8 |
| 15–40A, Three-Pole Fuse Block | V5-T4-17 |
| 15–75A, Reversing and Two-Speed—C65 | V5-T4-20 |

Starters

| | |
|--|-----------------|
| 25–60A, Single- and Three-Phase—A25, B25 | V5-T4-23 |
| 15–45A, Single- and Three-Phase—A27, B27 | V5-T4-30 |
| 15–75A, Single- and Three-Phase—A30, B30 and C440/XT Electronic Overload Relay | V5-T4-38 |

Features

- Completely encased design impervious to dust and other environmental elements
- 15–360A contactor ratings
- Single-, two-, three- and four-pole configurations
- Contactors and starters (up to 60A)
- Open components and enclosed designs

Catalog Number Selection

Definite Purpose Control—Contactors and Starters

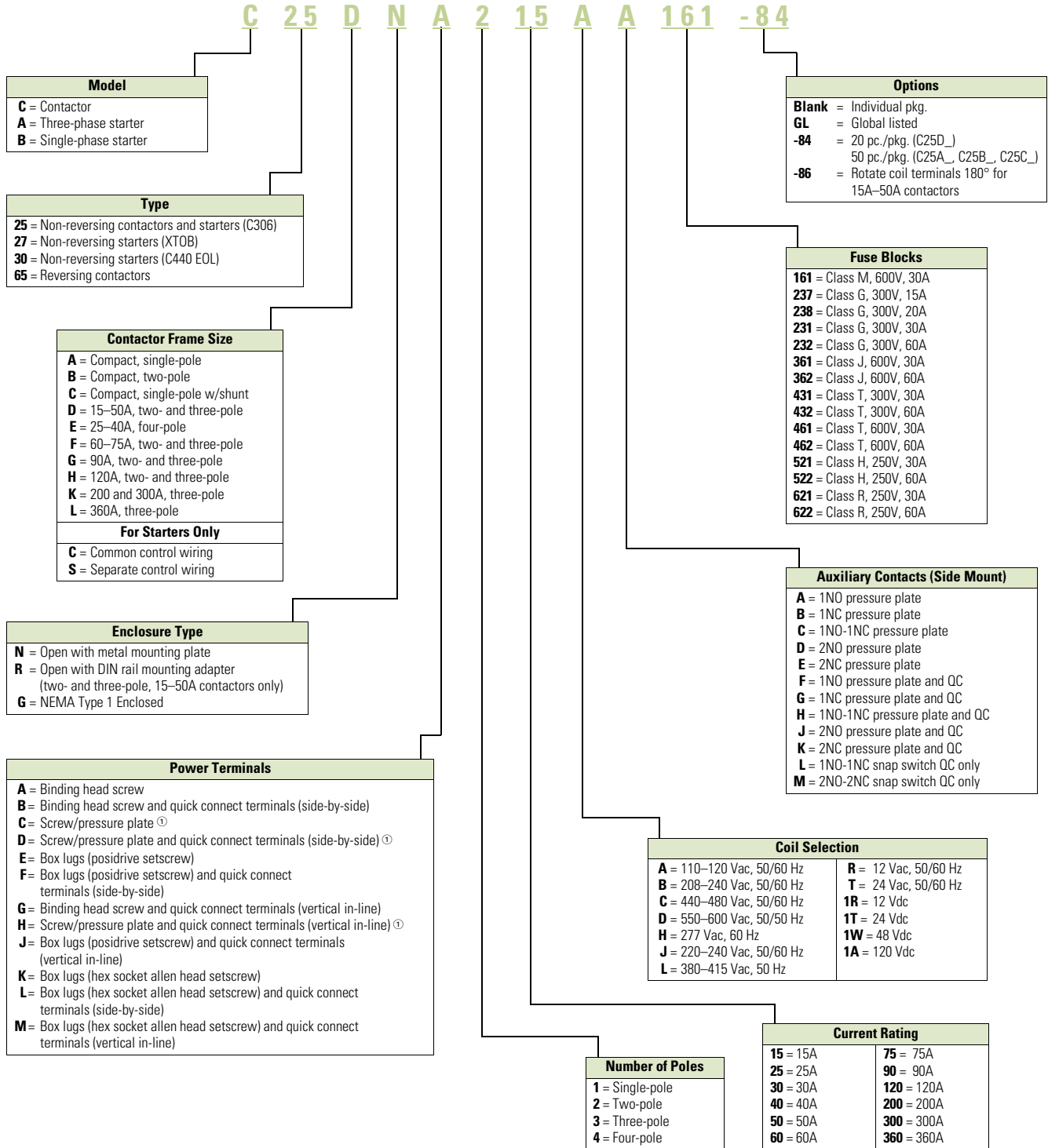

Note

① Not available on 50A devices.

20–40A, Compact Single- and Two-Pole—C25



Contents

| <i>Description</i> | <i>Page</i> |
|---|-----------------|
| 20–40A, Compact Single- and Two-Pole—C25 | |
| Catalog Number Selection | V5-T4-5 |
| Product Selection | V5-T4-5 |
| Options | V5-T4-6 |
| Technical Data and Specifications | V5-T4-6 |
| Dimensions | V5-T4-7 |
| 15–360A, Two-, Three- and Four-Pole—C25 | V5-T4-8 |
| 15–40A, Three-Pole Fuse Block | V5-T4-17 |
| 15–75A, Reversing and Two-Speed—C65 | V5-T4-20 |

20–40A, Compact Single- and Two-Pole—C25

Product Description

Eaton’s 20–40A, single- and two-pole, Type C25 contactors from Eaton’s Electrical Sector feature a compact, efficient design with a low VA coil and straight-through wiring. New contactor housing design effectively limits dust and other contaminants from magnet structure—reduces or eliminates noise. These economically priced, UL recognized/CSA certified, ampere rated devices are well suited for use in heating/air conditioning, refrigeration, data processing and food service applications.

Standards and Certifications

- UL Recognized Components: UL File Number E1491, Guides NLDX2 and NLDX8
- CSA Certified Components: CSA C22.2 No. 14-05, File Number 238083 Class 3211 84
- IEC 60947-4-1
- EN 60947-4-1
- ARI 780/790 Standard
- CE
- RoHS Compliance



Catalog Number Selection

20–40A, Compact Single- and Two-Pole—C25





When Ordering Specify

- Catalog number plus magnet coil suffix, see below
- Modify catalog number for any options required, see Options, **Page V5-T4-6**

Product Selection

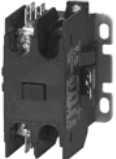
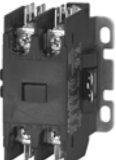
Compact Contactors—Open Type

| | Ampere Rating ^① | | | Locked Rotor | | Maximum Motor (hp) | | Maximum Motor (kW) | | Catalog Number ^{②③} | |
|---|-------------------------------|-----------|-----|--------------|------|--------------------|-------|--------------------|------|------------------------------|-------------------|
| | Inductive Full Load | Resistive | | 240–277V | 480V | 575V | 115V | 230V | 115V | | 230V |
| Single-Pole | Single-Pole | | | | | | | | | | |
|  | 25 | 30 | 150 | — | — | — | 2 | 3 | 1.5 | 2.2 | C25ANB125_ |
| | 30 | 40 | 150 | 75 | 50 | — | 2 | 5 | 1.5 | 3.7 | C25ANB130_ |
| | 40 | 50 | 240 | — | — | — | 3 | 7-1/2 | 2.2 | 5.5 | C25ANB140_ |
| Single-Pole with Shunt | Single-Pole with Shunt | | | | | | | | | | |
|  | 25 | 30 | 150 | — | — | — | 2 | 3 | 1.5 | 2.2 | C25CNB125_ |
| | 30 | 40 | 150 | 75 | 50 | — | 2 | 5 | 1.5 | 3.7 | C25CNB130_ |
| | 40 | 50 | 240 | — | — | — | 3 | 7-1/2 | 2.2 | 5.5 | C25CNB140_ |
| Two-Pole | Two-Pole | | | | | | | | | | |
|  | 20 | 30 | 120 | 100 | 80 | — | 1-1/2 | 3 | 1.1 | 2.2 | C25BNB220_ |
| | 25 | 35 | 150 | 125 | 100 | — | 2 | 3 | 1.5 | 2.2 | C25BNB225_ |
| | 30 | 40 | 150 | 125 | 100 | — | 2 | 5 | 1.5 | 3.7 | C25BNB230_ |
| | 40 | 50 | 240 | 200 | 160 | — | 3 | 7-1/2 | 2.2 | 5.5 | C25BNB240_ |

Magnet Coil Suffix

| AC Coil Voltage 50/60 Hz | Coil Suffix |
|----------------------------------|-------------|
| 24 | T |
| 110–120 | A |
| 208–240 | B |
| 277 | H |
| 380–415 (50 Hz), 440–480 (60 Hz) | C |

Notes

- ① Rating per pole.
- ② Incomplete catalog number. Replace underscore (_) in catalog number with coil suffix letter from the table above.
- ③ Bulk pack quantities are available in quantities of 50, contact local sales office.

Options**When Ordering Specify**

To order replace letter in the **6th** position of catalog number with letter **F**. Example: C25BN**F**240A.

Compact Factory Installed Options**Description**

| |
|--|
| Box lugs with quick connects for 20–40A contactors |
| Single-pole |
| Single-pole with shunt |
| Two-pole |

Technical Data and Specifications**20–40A, Compact Single- and Two-Pole—C25**

| Description | Specification |
|--|---|
| Insulation voltage | 690V |
| Current rated and hp/kw rated contacts | Double break |
| Magnet coil | Class F, 155°C |
| Contact arc covers | Standard on all contactors |
| Standard power terminals | 5/16 in hex washer head screws Quad (4) quick connect terminals on all line and load terminals Box lugs available as option |
| Line and load terminal designations | Marked on contactors |
| Operating temperature range | –13° to 158°F (–25° to 70°C) |
| Terminal wire range | |
| Hex washer head screws | 6–10 AWG, 30 lb-in torque rating |
| Box lugs | 6–10 AWG, 35 lb-in torque rating 8 AWG, 40 lb-in torque rating 6–4 AWG, 45 lb-in torque rating |
| Mounting position | Vertical, horizontal or tabletop |

Coil Characteristics

| AC Coil Voltage 50/60 Hz | Maximum Inrush VA | Maximum Sealed VA | Maximum Sealed Watts |
|--------------------------|-------------------|-------------------|----------------------|
| Single-Pole | | | |
| 24 | 33 | 6 | 2 |
| 120 | 33 | 6 | 2 |
| 208/240 | 33 | 6 | 2 |
| 277 | 33 | 6 | 2 |
| Two-Pole | | | |
| 24 | 41 | 6.5 | 3 |
| 120 | 41 | 6.5 | 3 |
| 208/240 | 41 | 6.5 | 3 |
| 277 | 41 | 6.5 | 3 |
| 480 | 41 | 6.5 | 3 |

Dimensions

Approximate Dimensions in Inches (mm)

20–40A, Compact Single- and Two-Pole—C25

Single-Pole and Single-Pole + Shunt

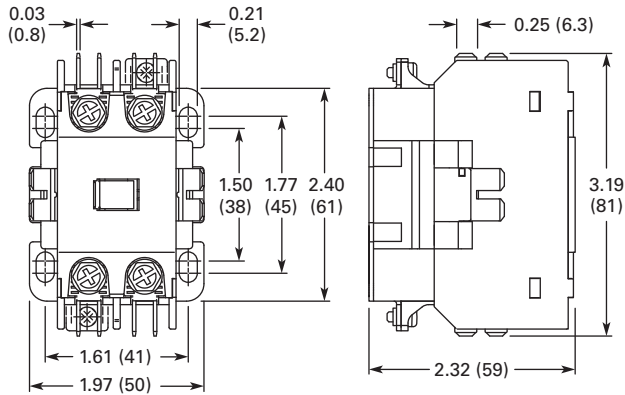

Approximate Shipping Weight

0.5 lb (0.2 kg)

Two-Pole

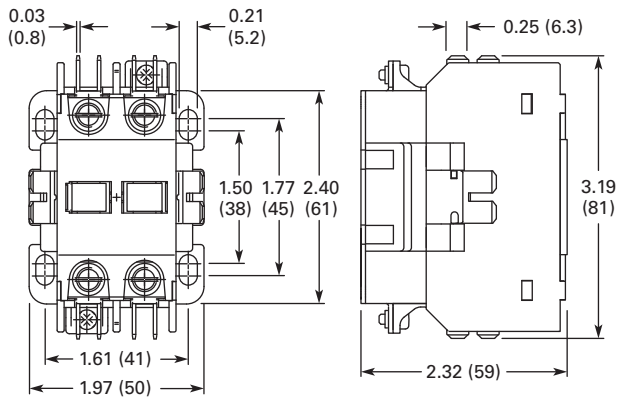

Approximate Shipping Weight

0.7 lb (0.3 kg)

15–360A, Two-, Three- and Four-Pole—C25

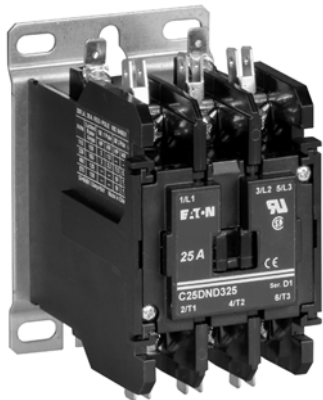

15–360A, Two-, Three- and Four-Pole—C25

Product Description

Eaton offers the most comprehensive line of definite purpose contactors in the industry. Initially designed as an HVAC and refrigeration product, the C25 line is now the market leader and the product of choice for many OEMs and contractors serving diverse markets. Featuring current ratings between 15A and 360A, the contactors are dual-rated for inductive and resistive ratings as well as for horsepower and kilowatt ratings.

Other terminal configurations are available, see **Page V5-T4-13**. Contactors will accept add-on auxiliary contacts—order factory assembled or as kits for field installation.

The separately available snap-on mechanical interlock permits interlocking two contactors for reversing or two-speed applications.

Contactors between 15A and 50A are offered as two different lines—Standard and Global Listed.

Standard DP Contactors (15–50A, Two- and Three-Pole)

The standard line of C25 DP contactor features:

- Pressure plates and quick connects are standard on 15–30A contactors
- Lugs and quick connects are standard on 40A and 50A contactors
- Highest electrical life in its class—minimum 250,000 operations
- Universal baseplate allows for easy retrofit of competitive units (optional DIN rail mounting)
- UL recognized design in U.S. and Canada “cURus” (CSA approval pending)
- Accessories including auxiliary contacts, mechanical interlocks and fuse blocks
- RoHS (Reduction of Hazardous Substances) compliant

Contents

| <i>Description</i> | <i>Page</i> |
|--|-----------------|
| 20–40A, Compact Single- and Two-Pole—C25 . . . | V5-T4-4 |
| 15–360A, Two-, Three- and Four-Pole—C25 | |
| Product Selection | V5-T4-9 |
| Accessories | V5-T4-11 |
| Options | V5-T4-13 |
| Technical Data and Specifications | V5-T4-14 |
| Dimensions | V5-T4-16 |
| 15–40A, Three-Pole Fuse Block | V5-T4-17 |
| 15–75A, Reversing and Two-Speed—C65 | V5-T4-20 |

Standards and Certifications

- UL Recognized Components UL File #E-1491, Guide NLDX2
- CSA Certified Components (excluding 90A) File #LR353, Class 3211 04, 481301 and 122201
- CE mark (Global line only) EN 60947-4-1
- RoHS Compliance (15A to 50A and 90A)



Product Selection

When Ordering Specify

- Catalog number plus magnet coil suffix, see **Page V5-T4-10**
- Catalog numbers of accessory kits required, see Accessories, **Page V5-T4-11**
- Modify catalog number for any options required, see Options, **Page V5-T4-13**

DP Contactor

C25 Contactors—Open Type



| Ampere Rating | | Line Voltage | Locked Rotor | Maximum Motor (hp) | | Maximum Motor (kW) | | Number of Poles | Standard DP Contactors | | Global Listed Line |
|---------------------|--------------------|--------------|--------------|--------------------|-------------|--------------------|-------------|-----------------|---------------------------------|--|---------------------------------|
| Inductive Full Load | Resistive per Pole | | | Single-Phase | Three-Phase | Single-Phase | Three-Phase | | With Baseplate Catalog Number ① | With DIN Rail Adapter Catalog Number ① | With Baseplate Catalog Number ① |
| 15 | 20 | 115 | 90 | 3/4 | — | 0.40 | — | 2 | C25DND215_ | C25DRD215_ | C25DND215_-GL |
| | | 230 | 90 | 2 | 3 | 1.5 | 2.2 | 3 | C25DND315_ | C25DRD315_ | C25DND315_-GL |
| | | 460 | 75 | — | 5 | — | 3.7 | | | | |
| | | 575 | 60 | — | 5 | — | 3.7 | | | | |
| 25 | 35 | 115 | 150 | 2 | — | 1.5 | — | 2 | C25DND225_ | C25DRD225_ | C25DND225_-GL |
| | | 230 | 150 | 3 | 7-1/2 | 2.2 | 5.5 | 3 | C25DND325_ | C25DRD325_ | C25DND325_-GL |
| | | 460 | 125 | — | 10 | — | 7.5 | 4 | C25END425_ | — | — |
| | | 575 | 100 | — | 10 | — | 7.5 | | | | |
| 30 | 40 | 115 | 180 | 2 | — | 1.5 | — | 2 | C25DND230_ | C25DRD230_ | C25DND230_-GL |
| | | 230 | 180 | 5 | 10 | 3.7 | 7.5 | 3 | C25DND330_ | C25DRD330_ | C25DND330_-GL |
| | | 460 | 150 | — | 15 | — | 11 | 4 | C25END430_ | — | — |
| | | 575 | 120 | — | 15 | — | 11 | | | | |
| 40 | 50 | 115 | 240 | 3 | — | 2.2 | — | 2 | C25DNF240_ | C25DRF240_ | C25DNF240_-GL |
| | | 230 | 240 | 7-1/2 | 10 | 5.5 | 7.5 | 3 | C25DNF340_ | C25DRF340_ | C25DNF340_-GL |
| | | 460 | 200 | — | 20 | — | 15 | 4 | C25ENF440_ | — | — |
| | | 575 | 160 | — | 20 | — | 15 | | | | |
| 50 | 65 | 115 | 300 | 3 | — | 2.2 | — | 2 | C25DNJ250_ | C25DRJ250_ | C25DNJ250_-GL |
| | | 230 | 300 | 10 | 15 | 7.5 | 11 | 3 | C25DNJ350_ | C25DRJ350_ | C25DNJ350_-GL |
| | | 460 | 250 | — | 30 | — | 22 | | | | |
| | | 575 | 200 | — | 30 | — | 22 | | | | |
| 60 | 75 | 115 | 360 | 5 | — | 3.7 | — | 2 | C25FNF260_ | — | — |
| | | 230 | 360 | 10 | 20 | 7.5 | 15 | 3 | C25FNF360_ | — | — |
| | | 460 | 300 | — | 40 | — | 30 | | | | |
| | | 575 | 240 | — | 40 | — | 30 | | | | |
| 75 | 90 | 115 | 450 | 5 | — | 3.7 | — | 2 | C25FNF275_ | — | — |
| | | 230 | 450 | 15 | 20 | 11 | 18.5 | 3 | C25FNF375_ | — | — |
| | | 460 | 375 | — | 50 | — | 37 | | | | |
| | | 575 | 300 | — | 50 | — | 37 | | | | |
| 90 | 120 | 115 | 540 | 7-1/2 | — | 5.5 | — | 2 | C25GNF290_ | — | — |
| | | 230 | 540 | 15 | 30 | 11 | 22 | 3 | C25GNF390_ | — | — |
| | | 460 | 450 | — | 50 | — | 37 | | | | |
| | | 575 | 360 | — | 50 | — | 37 | | | | |
| 120 | 140 | 230 | 720 | — | — | — | — | 3 | C25HNE3120_ | — | — |
| | | 460 | 720 | | | | | | | | |
| | | 575 | 570 | | | | | | | | |
| 200 | 200 | 240 | 1200 | — | — | — | — | 3 | C25KNE3200_ | — | — |
| | | 480 | 1200 | | | | | | | | |
| | | 600 | 1000 | | | | | | | | |
| 300 | 300 | 240 | 1800 | — | — | — | — | 3 | C25KNE3300_ | — | — |
| | | 480 | 1800 | | | | | | | | |
| | | 600 | 1500 | | | | | | | | |
| 360 | 360 | 240 | 2320 | — | — | — | — | 3 | C25LNE3360_ | — | — |
| | | 480 | 2320 | | | | | | | | |
| | | 600 | 1900 | | | | | | | | |

Note

① Incomplete catalog number. Replace underscore (_) in catalog number with magnet coil suffix from table on **Page V5-T4-10**.

Magnet Coil Suffix

| AC ① | | | DC ⑤ | |
|-----------------|-----------------|--------------------|-----------------|--------------------|
| 60 Hertz | 50 Hertz | Coil Suffix | 60 Hertz | Coil Suffix |
| 12 ② | 12 | R | 12 | 1R |
| 24 ③ | 24 | T | 24 | 1T |
| 110–120 ④ | 110–120 ④ | A | 48 | 1W |
| 208 ⑥ | — | E | 120 | 1A ⑧ |
| 208–240 ⑥ | 208–240 | B | | |
| 240 ⑦ | 220 | J | | |
| 277 | — | H | | |
| — | 380–415 | L | | |
| 440–480 | 440–480 | C | | |
| 550–600 ⑥ | 550–600 | D | | |

Notes

- ① Class H AC coils available as option for 15A–50A contactor. Add 2 before AC coil suffix letter.
- ② Available through 75A.
- ③ Available through 120A.
- ④ 104–120V 50/60 Hz for 60A, 75A and all four-pole contactors (25A–40A).
- ⑤ Available 120–360A.
- ⑥ Available 15–90A, others 240V.
- ⑦ Available through 50A.
- ⑧ Not available for 90A.
- ⑨ Contactors with DC coils (only available up to 75A) include an early break NC auxiliary contact, C320KGD1. See **Page V5-T4-62** for more details.
- ⑩ Available only for 15A through 75A contactors and four-pole contactors.

Accessories

Auxiliary Contact Kits (Side Mounted)

Heavy-Duty Pilot Rated for 10A at 600 Vac

Side Mounted Auxiliary Contact

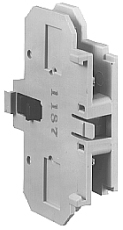

| Circuit | With Standard Pressure Plate Terminals Catalog Number | With Pressure Plate and Quick Connect Terminals Catalog Number |
|---------------------------|--|---|
| For 15 through 75A | | |
| 1NO | C320KG1 | C320KG11 |
| 1NC | C320KG2 | C320KG12 |
| 1NO-1NC | C320KG3 | C320KG13 |
| 2NO | C320KG4 | C320KG14 |
| 2NC | C320KG5 | C320KG15 |

Auxiliary Contact for FI Series Contactors



| | | |
|----------------|---|--------------------------|
| For 90A | | |
| 1NO | — | FIC320DPG10 ^① |
| 1NC | — | FIC320DPG01 ^① |
| 1NO-1NC | — | FIC320DPG11 ^① |
| 2NO | — | FIC320DPG20 ^① |

| | | |
|-----------------------------|-----------|---|
| For 120 through 360A | | |
| 1NO | C320KGS20 | — |
| 1NC | C320KGS21 | — |
| 1NO-1NC | C320KGS22 | — |

Side Mounted Snap Switch



Snap Switch Design Side Mounted Auxiliary Contacts (For 15–75A Contactors Only)

| Circuit | Snap Switch Design with Quick Connect Terminals Catalog Number |
|---------|---|
| 1NO-1NC | C320SNP11 |
| 2NO-2NC | C320SNP22 |

Magnet Coil Quick Connect Terminal

Description

Extra dual quick connect terminals (U-shaped) for magnet coil terminals ^②

Notes

- ① Valid on Series **FI** contactors only.
- ② To order, add suffix number **9** to the complete catalog number.
Example: C25DND215A**9**.

Auxiliary Contact Kits (Top Mounted)

Top Mounted Auxiliary Contact



Heavy-Duty Pilot Rated for 10A at 600 Vac

| With Standard Pressure Plate Terminals | | With Standard Pressure Plate Terminals | |
|--|------------------|--|------------------|
| Circuit | Catalog Number | Circuit | Catalog Number |
| For 15 through 75A ^① | | | |
| 1NO | C320KGT1 | 1NO-2NC | C320KGT11 |
| 1NC | C320KGT2 | 3NC | C320KGT12 |
| 1NO-1NC | C320KGT3 | 4NO | C320KGT13 |
| 2NO | C320KGT4 | 3NO-1NC | C320KGT14 |
| 2NC | C320KGT5 | 2NO-2NC | C320KGT15 |
| 3NO | C320KGT9 | 1NO-3NC | C320KGT16 |
| 2NO-1NC | C320KGT10 | 4NC | C320KGT17 |

Mechanical Interlock



Mechanical Interlock Kit

| Description | Catalog Number |
|---|------------------|
| Mechanical interlock kit for 15 through 75A | C321KM60B |

Solid-State ON DELAY Timer

Side mounted on C25D, C25E and C25F frame.

This timer is designed to be **wired in series with the load** (typically a coil). When the START button is pushed (power applied to timer), the ON DELAY timing function starts. At the completion of the set timing period, timer and series wired load will both be energized.

Solid-State ON DELAY Timer



Solid-State ON DELAY Timer

| Timing Range | Catalog Number ^{②③④} |
|-----------------|-------------------------------|
| 0.1–1.0 seconds | C320TDN1_ |
| 1–30 seconds | C320TDN30_ |
| 30–300 seconds | C320TDN300_ |
| 5–30 minutes | C320TDN3000_ |

Separate Enclosures

NEMA 1 Enclosure



Separate Enclosures—NEMA 1

| Application | Catalog Number |
|---|----------------|
| 15 through 50A, two- and three-pole | C799B18 |
| 60A, two- and three-pole or 25 through 40A, four-pole | C799B19 |

Notes

- ① Not available for four-pole contactors (15–40 Amp).
- ② Add operating voltage suffix to catalog number.
A = 120V, **B** = 240V, **E** = 208V
- ③ Rated 0.5 ampere pilot duty—not to be used on larger contactors.
- ④ Terminal connections are quick connects only. Two per side.

Options

To order C25, C65, A25 and B25 contactors and starters with the factory installed options listed below, change the basic catalog number listed in the product selection table as noted.

Factory Installed Options

| Description | Code Letter | Number of Poles |
|---|-------------|-----------------------------|
| Terminals— 15A through 50A | | |
| Binding head screws | | |
| Without quick connect terminals | A | 2-, 3-, 4-pole |
| With quick connect terminals (side-by-side) | B | 2-, 3-, 4-pole |
| With quick connect terminals (vertical in-line) | G | 2-, 3-pole |
| Screw/pressure plate ^① | | |
| Without quick connect terminals | C | 2-, 3-, 4-pole |
| With quick connect terminals (side-by-side) | D | 2-, 3-, 4-pole |
| With quick connect terminals (vertical in-line) | H | 2-, 3-pole |
| Box lugs (#2 posidrive/slotted screw) | | |
| Without quick connect terminals | E | 2-, 3-, 4-pole ^② |
| With quick connect terminals (side-by-side) | F | 2-, 3-, 4-pole ^② |
| With quick connect terminals (vertical in-line) | J | 2-, 3-pole |
| Box lugs (hex socket allen head screw) | | |
| Without quick connect terminals | K | 2-, 3-pole |
| With quick connect terminals (side-by-side) | L | 2-, 3-pole |
| With quick connect terminals (vertical in-line) | M | 2-, 3-pole |
| Terminals— 60A through 75A ^③ | | |
| Box lugs (slotted screw) | | |
| Without quick connect terminals | E | 2-, 3-pole |
| With quick connect terminals | F | 2-, 3-pole |

Field Installed Options

| Description | Catalog Number |
|--------------------------------|---------------------------------|
| Finger-proof shield for 15–50A | 49-7899KIT ^{④⑤} |

Auxiliary Contacts (Side Mount)

Add code letter listed below to complete catalog number.

Example: Change C25DND215**A** to C25DND215**AA**.

Auxiliary Contacts— Factory Installed

| Description | With Standard Pressure Plate Terminals Code Letter | With Quick Connect Terminals Code Letter | Snap Switch Design with Quick Connect Terminals Code Letter |
|--|---|---|--|
| For 15 through 90A ^④ | | | |
| 1NO | A | F | — |
| 1NC | B | G | — |
| 1NO-1NC | C | H | — |
| 2NO | D | J | — |
| 2NC | E | K | — |
| For 15 through 75A | | | |
| 1NO-1NC | — | — | L |
| 2NO-2NC | — | — | M |
| For 120 through 360A | | | |
| 1NO | A | — | — |
| 1NO-1NC | C | — | — |
| 2NO | D | — | — |
| 2NC | E | — | — |
| Special Marking (Special contactor marking, consult local sales office) | | | |

Notes

- ① Screw/pressure plate terminals are not available on 50A contactors.
- ② Four-pole contactors have box lugs with slotted screws.
- ③ Replace letter in the **6th** position of catalog number with code letter listed. Example: Change C25F**NF**250 to C25F**NE**250.
- ④ 90A available only with binding head screw and quick connect terminals.
- ⑤ Kit contains quantity 1 shield.
- ⑥ Not for use with Quick Connect terminals on the power poles.

Technical Data and Specifications

Standard and Global Listed Line

15–360A, Two-, Three- and Four-Pole—C25

| Description | Standard | Global Listed Line |
|------------------------------|---|---|
| Magnet coil | Class B (C25E, F, G, H and K), 130°C Class F (C25D and L), 155°C Class H (C25D), 180°C (available as factory installed option) | Class B (C25E, F, G, H and K), 130°C Class F (C25D and L), 155°C Class H (C25D), 180°C (available as factory installed option) |
| Contacts | Double break | Double break |
| Coil terminals | 18 AWG (90A) | 18 AWG (90A) |
| Ambient temperature | 150°F (65°C) maximum | 150°F (65°C) maximum |
| Terminal wire range | | |
| #8–32 binding head screw | 14–12 AWG (one conductor-solid) | 14–12 AWG (one conductor-solid) |
| #8–32 screw/pressure plate | 14–8 AWG (one conductor); 14–8 AWG (two conductors) | 14–8 AWG (one conductor); 14–8 AWG (two conductors) |
| Box lugs—15–50A ^① | # 2 posidrive screw or 5/32 hex socket screw Upper level: 14–4 AWG (one conductor) Lower level: 14–6 AWG (one conductor) | # 2 posidrive screw or 5/32 hex socket screw Upper level: 14–4 AWG (one conductor) Lower level: 14–6 AWG (one conductor) |
| Box lugs—60–75A ^① | Upper level: 14–2 AWG Lower level: 14–6 AWG | Upper level: 14–2 AWG Lower level: 14–6 AWG |
| Box lugs—90A | 1/0–8 AWG | 1/0–8 AWG |
| Box lugs—120A | 3/0–8 AWG | 3/0–8 AWG |
| Box lugs—200–300A | 350 kcmil–6 AWG | 350 kcmil–6 AWG |
| Box lugs—360A | 750 kcmil–2 AWG | 750 kcmil–2 AWG |

Contactors Torque Ratings

| Contactors Size | Terminal | Wire Range | Tightening Torque |
|---------------------|-------------------------|----------------------|-------------------|
| 15–50A ^② | 8–32 binding head screw | 12–14 AWG | 22 lb-in |
| | | Screw/pressure plate | 8–14 AWG |
| | Box lug | 12–14 AWG | 15 lb-in |
| | | 10 AWG | 25 lb-in |
| | | 8 AWG | 40 lb-in |
| 60–75A ^③ | Box lug | 4–6 AWG | 45 lb-in |
| | | 10–14 AWG | 40 lb-in |
| | | 8 AWG | 45 lb-in |
| | | 3–6 AWG | 50 lb-in |
| 90A | Box lug | 1/0–8 AWG | 60 lb-in |
| 120A | Box lug | 8 AWG | 40 lb-in |
| | | 4–6 AWG | 45 lb-in |
| | | 3–1/0 AWG | 50 lb-in |
| 200–300A | Box lug | 6–350 kcmil | 200 lb-in |
| 360A | Box lug | 2–750 kcmil | 550 lb-in |

Notes

- ① The box lugs on the 15–75A device can accept two conductors per pole.
- ② The box lugs on the 15–50A device can accept two conductors per pole, the upper section will accept 4–14 AWG and the lower section will accept 6–14 AWG.
- ③ The box lugs on the 60–75A device can accept two conductors per pole, the upper section will accept 3–14 AWG and the lower section will accept 6–14 AWG.

For Global Line Only

DC Ratings (Global Listed Line Only)

| Voltage | Two-Pole, 15–30A Inductive | | | Two-Pole, 40A Inductive | | | Three-Pole, 15–30A Inductive | | | Three-Pole, 40A Inductive | | |
|-------------------------------|----------------------------|------|----------------|-------------------------|-----|----------------|------------------------------|------|----------------|---------------------------|-----|----------------|
| | UL/CSA | | DC-3/DC-5 | UL/CSA | | DC-3/DC-5 | UL/CSA | | DC-3/DC-5 | UL/CSA | | DC-3/DC-5 |
| | FLA | hp | I _e | FLA | hp | I _e | FLA | hp | I _e | FLA | hp | I _e |
| 240 Vdc three poles in series | — | — | — | — | — | — | 4 | 3/4 | 4 | 5 | 1 | 5 |
| 120 Vdc three poles in series | — | — | — | — | — | — | 8 | 3/4 | 8 | 10 | 1 | 10 |
| 120 Vdc two poles in series | 5.5 | 1/2 | 5.5 | 8 | 3/4 | 8 | 5.5 | 1/2 | 5.5 | 8 | 3/4 | 8 |
| 120 Vdc per pole | 2 | 1/10 | 2 | 3.5 | 1/4 | 3.5 | 2 | 1/10 | 2 | 3.5 | 1/4 | 3.5 |
| 24 Vdc per pole | 15 | — | 15 | 20 | — | 20 | 15 | — | 15 | 20 | — | 20 |

Lighting Duty Ratings (Global Listed Line Only)

| C25D_ Inductive Rating | Tungsten and Ballast (480V) |
|------------------------|-----------------------------|
| 25A | 30A |
| 30A | 40A |
| 40A | 50A |
| 50A | 60A |

IEC/CE Ratings (IEC 60947-4-1, EN 60947-4-1) for 15A through 50A C25 D–Contactors (Global Listed Line Only)

| C25D_ Inductive Rating | AC-1 (I _c) | | AC-3 (I _e) | | AC-4 (I _e) | | AC-8a | |
|------------------------|------------------------|------|------------------------|------|------------------------|------|-------|------|
| | 480V | 600V | 480V | 600V | 480V | 600V | 480V | 600V |
| 15A | 20A | 20A | 15A | 15A | 15A | — | 15A | 15A |
| 25A | 30A | 30A | 25A | 25A | 25A | — | 25A | 25A |
| 30A | 40A | 40A | 30A | 30A | 30A | — | 30A | 30A |
| 40A | 50A | — | 40A | — | 40A | — | 40A | — |
| 50A | 65A | 65A | 50A | 50A | 50A | — | 50A | 50A |

4.2

Definite Purpose Contactors and Starters

Contactors

4

Dimensions

Approximate Dimensions in Inches (mm)

C25 Contactors, Open Type and Open Type—Reversing

15–75 Ampere (Non-Reversing)

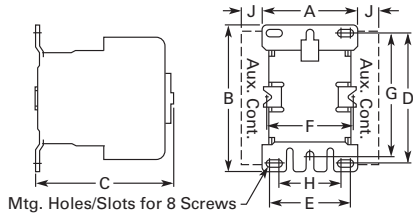

15–75 Ampere (Reversing)

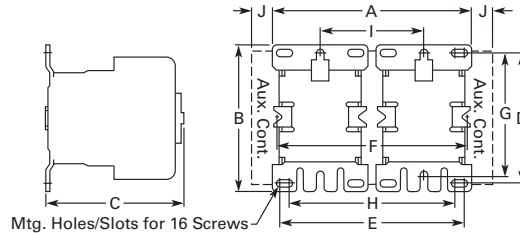

90 Ampere

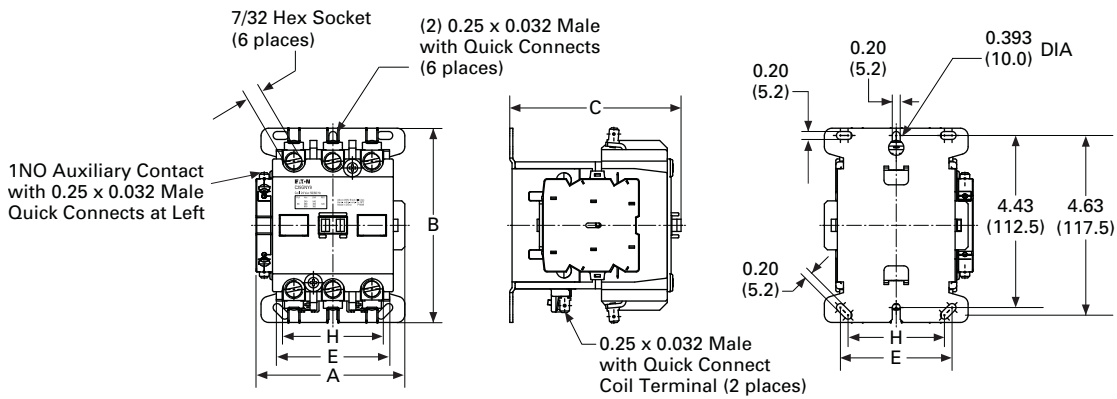

120 Ampere

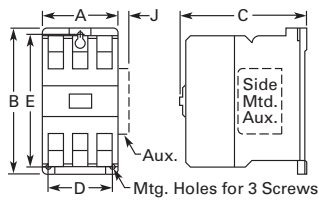

200–360 Ampere

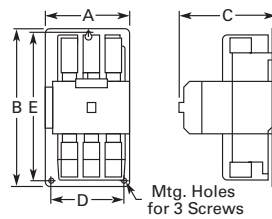

Dimensions and Shipping Weights

| Ampere Size | Number of Poles | Wide A | High B | Deep C | Mounting D | E | F | G | H | Side Auxiliary Contact Adder J | Shipping Weight Lbs (kg) |
|----------------------------|-----------------|---------------|---------------|--------------|--------------|---------------|-------------|-------------|--------------|--------------------------------|--------------------------|
| Open Type | | | | | | | | | | | |
| 15–50 | 2 and 3 | 2.40 (61.0) ① | 3.75 (95.0) | 3.35 (85.0) | 3.25 (83.0) | 2.00 (51.0) | — | 3.13 (79.0) | 1.50 (38.0) | 0.34 (8.6) | 1.3 (.6) |
| 25–40 | 4 | 2.68 (68.0) ① | 3.75 (95.0) | 3.38 (86.0) | 3.25 (83.0) | 2.00 (51.0) | 1.50 (38.0) | 3.13 (79.0) | 1.50 (38.0) | 0.50 (12.5) | 2.3 (1.0) |
| 60–75 | 2 and 3 | 2.63 (67.0) ① | 3.75 (95.0) | 3.97 (101.0) | 3.25 (83.0) | 2.00 (51.0) | 1.50 (38.0) | 3.13 (79.0) | 1.50 (38.0) | 0.37 (9.5) | 2.8 (1.3) |
| 90 | 2 and 3 | 3.86 (98.0) | 5.00 (127.0) | 4.41 (112.0) | — | 2.87 (73.0) | — | — | 2.48 (63.0) | — | NN (NN) |
| 120 | 2 and 3 | 3.54 (90.0) | 7.17 (182.0) | 5.94 (151.0) | 3.00 (76.0) | 6.63 (168.0) | — | — | — | 0.54 (13.7) | 8.5 (3.9) |
| 200 and 300 | 2 and 3 | 7.05 (179.0) | 9.11 (232.0) | 7.25 (184.0) | 6.00 (152.0) | 8.50 (216.0) | — | — | — | — | 20.0 (9.1) |
| 360 | 2 and 3 | 7.05 (179.0) | 13.12 (333.0) | 7.78 (198.0) | 6.00 (152.0) | 12.50 (318.0) | — | — | — | — | 23.0 (10.4) |
| Open Type—Reversing | | | | | | | | | | | |
| 15–50 | 2 and 3 | 5.0 (127.0) | 3.75 (95.0) | 3.35 (85.0) | 3.25 (83.0) | 4.53 (118.0) | — | 3.13 (79.0) | 4.13 (105.0) | 0.34 (8.6) | 2.6 (1.2) |
| 60–75 | 2 and 3 | 5.77 (147.0) | 3.75 (95.0) | 3.97 (101.0) | 3.25 (83.0) | 5.15 (131.0) | 3.15 (80.0) | 3.13 (79.0) | 4.65 (118.0) | 0.37 (9.5) | 5.6 (2.5) |

Note

① Add 0.30 in (8 mm) to width for C25 contactors with DC coils.

15–40A, Three-Pole Fuse Block

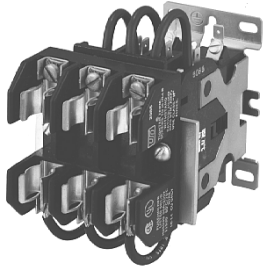

Contents

| Description | Page |
|---|-----------------|
| 20–40A, Compact Single- and Two-Pole—C25 . . . | V5-T4-4 |
| 15–360A, Two-, Three- and Four-Pole—C25 | V5-T4-8 |
| 15–40A, Three-Pole Fuse Block | |
| Product Selection | V5-T4-18 |
| Dimensions | V5-T4-19 |
| 15–75A, Reversing and Two-Speed—C65 | V5-T4-20 |

15–40A, Three-Pole Fuse Block

Product Description

Designed to save space and reduce installation costs, these three-pole fuse blocks will accommodate a variety of fuse classes and fuse holders to satisfy a wide range of electrical/electronic applications such as commercial space and water heaters, dishwashers, food coolers and sterilizing equipment. They are supplied either factory assembled, mounted and wired to the contactor or in kit form.

Note: Available only on three-pole, 15–50A contactors

Product Selection**Optional Three-Pole Fuse Block****Available only on three-pole, 15–50A contactors**

Designed to save space and reduce installation costs, these three-pole fuse blocks will accommodate a variety of fuse classes and fuse holders to satisfy a wide range of electrical/electronic applications such as commercial space and water heaters, dishwashers, food coolers and sterilizing equipment. They are supplied either factory assembled, mounted and wired to the contactor or in kit form.

To order factory assembled, add suffix number from table below to catalog number of contactor listed on **Page V5-T4-9**. Example: C25DND325A**361**.

4

Three-Pole Fuse Block**Three-Pole Fuse Blocks**

| Fuse Holder Volts | Amperes | Fuse Dimensions in Inches (mm) | | Terminal Type | Maximum Wire Size | Factory Installed Ordering Suffix | Field Installation Kit Catalog Number |
|----------------------|---------|--------------------------------|-------------|----------------|----------------------|--------------------------------------|--|
| | | Diameter | Length | | | | |
| Class M | | | | | | | |
| 600 | 30 | 0.41 (10.4) | 1.50 (38.1) | Pressure plate | 10 AWG Cu | 161 | C350KM61 |
| Class G | | | | | | | |
| 600 | 15 | 0.41 (10.4) | 1.31 (33.3) | Pressure plate | 10 AWG Cu | 237 | C350KG37 |
| | 20 | | 1.41 (35.8) | Pressure plate | 10 AWG Cu | 238 | C350KG38 |
| 480 | 30 | 0.41 (10.4) | 1.63 (41.4) | Pressure plate | 10 AWG Cu | 231 | C350KG31 |
| | 60 | | 2.25 (57.2) | Box lug | 2 AWG Cu/Al | 232 | C350KG32 |
| Class J | | | | | | | |
| 600 | 30 | 0.81 (20.6) | 2.25 (57.2) | Pressure plate | 10 AWG Cu | 361 | C350KJ61 |
| | 60 | 1.06 (26.9) | 2.38 (60.5) | Box lug | 2 AWG Cu/Al | 362 | C350KJ62 |
| Class T | | | | | | | |
| 300 | 30 | 0.41 (10.4) | 0.88 (22.4) | Box lug | 6 AWG Cu | 431 | C350KT31 |
| | 60 | 0.56 (14.2) | 0.88 (22.4) | Box lug | 2 AWG Cu/Al | 432 | C350KT32 |
| 600 | 30 | 0.56 (14.2) | 1.50 (38.1) | Box lug | 6 AWG Cu | 461 | C350KT61 |
| | 60 | 0.81 (20.6) | 1.56 (39.6) | Box lug | 2 AWG Cu/Al | 462 | C350KT62 |
| Class H | | | | | | | |
| 250 | 30 | 0.56 (14.2) | 2.00 (50.8) | Pressure plate | 10 AWG Cu | 521 | C350KH21 |
| | 60 | 0.81 (20.6) | 3.00 (76.2) | Box lug | 2 AWG Cu/Al | 522 | C350KH22 |
| Class R | | | | | | | |
| 250 | 30 | 0.56 (14.2) | 2.00 (50.8) | Pressure plate | 10 AWG Cu | 621 | C350KR21 |
| | 60 | 0.81 (20.6) | 3.00 (76.2) | Box lug | 2 AWG Cu/Al | 622 | C350KR22 |

Dimensions

Approximate Dimensions in Inches (mm)

Three-Pole Fuse Block and Contactor

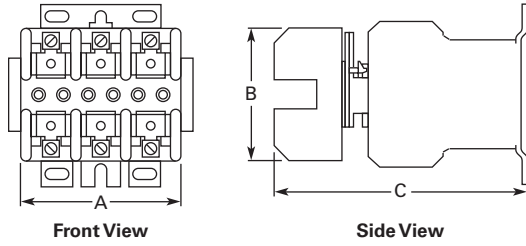

| Fuse Size Class | Amps | Volts | Wide A | High B | Deep C |
|-----------------|------|-------|------------|------------|------------|
| G | 15 | 600 | 2.41 (61) | 2.81 (71) | 5.14 (131) |
| | 20 | | 2.41 (61) | 2.81 (71) | 5.14 (131) |
| | 30 | 480 | 2.41 (61) | 2.81 (71) | 5.14 (131) |
| | 60 | | 2.62 (67) | 4.25 (108) | 5.18 (132) |
| H | 30 | 250 | 3.00 (76) | 3.03 (77) | 5.33 (135) |
| | 60 | | 4.22 (107) | 4.75 (121) | 5.86 (149) |
| J | 30 | 600 | 4.81 (122) | 4.12 (105) | 5.92 (150) |
| | 60 | | 4.81 (122) | 4.12 (105) | 5.92 (150) |
| M | 30 | 600 | 2.41 (61) | 2.81 (71) | 5.14 (131) |
| R | 30 | 250 | 3.00 (76) | 3.03 (77) | 5.33 (135) |
| | 60 | | 4.22 (107) | 4.75 (121) | 5.86 (149) |
| T | 30 | 300 | 3.44 (87) | 2.75 (70) | 5.43 (138) |
| | 60 | 300 | 3.44 (87) | 2.75 (70) | 5.43 (138) |
| | 30 | 600 | 3.75 (95) | 3.19 (81) | 5.36 (136) |
| | 60 | 600 | 4.87 (124) | 2.94 (75) | 5.68 (144) |

15–75A, Reversing and Two-Speed—C65

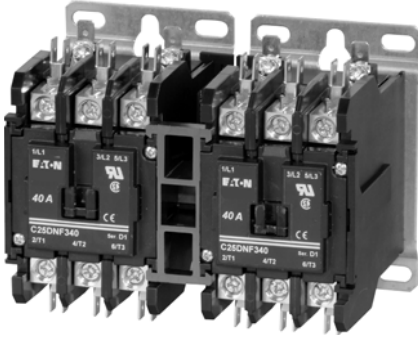

4

15–75A, Reversing and Two-Speed—C65

Product Description

C65 Reversing Contactors from Eaton’s Electrical Sector are furnished with pressure plates and quick connect terminals as standard on 15, 25 and 30A devices and with box lugs and quick connect terminals on 40, 50, 60 and 75A.

Other terminal configurations are available—see Factory Installed Options on **Page V5-T4-13**. Reversing contactors will accept add-on auxiliary contacts on either side—order factory assembled or as kits for field installation. See **Page V5-T4-13**.

Contents

Description

| | <i>Page</i> |
|---|-----------------|
| 20–40A, Compact Single- and Two-Pole—C25 . . . | V5-T4-4 |
| 15–360A, Two-, Three- and Four-Pole—C25 | V5-T4-8 |
| 15–40A, Three-Pole Fuse Block | V5-T4-17 |
| 15–75A, Reversing and Two-Speed—C65 | |
| Catalog Number Selection | V5-T4-21 |
| Product Selection | V5-T4-21 |

Standards and Certifications

- UL Recognized Components UL File #E-1491, Guide NLDX2
- CSA Certified Components File #LR353, Guide 380w-1.14 Class 3211 04
- CE



Catalog Number Selection

15–75A, Reversing and Two-Speed—C65

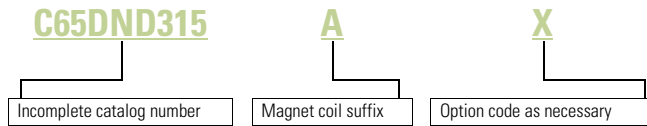

When Ordering Specify

- Catalog number plus magnet coil suffix, see **Page V5-T4-22**
- Catalog numbers of accessory kits required, see Accessories, **Page V5-T4-11**
- Modify catalog number for any options required, see Options, **Page V5-T4-13**

Product Selection

C65 Reversing Contactor



Open Type Contactors—Unwired, Mechanically Interlocked Only

| Ampere Rating | | Line Voltage | Locked Rotor | Maximum Motor (hp) | | Maximum Motor (kW) | | Number of Poles | Open Type with Metal Mounting Plate | Open Type with DIN Rail Adapter |
|---------------------|--------------------|--------------|--------------|--------------------|-------------|--------------------|-------------|-----------------|-------------------------------------|---------------------------------|
| Inductive Full Load | Resistive per Pole | | | Single-Phase | Three-Phase | Single-Phase | Three-Phase | | Catalog Number ^① | Catalog Number ^① |
| 15 | 20 | 115 | 90 | 3/4 | — | 0.40 | — | 2 | C65DND215_ | C65DRD215_ |
| | | 230 | 90 | 2 | 3 | 1.5 | 2.2 | 3 | C65DND315_ | C65DRD315_ |
| | | 460 | 75 | — | 5 | — | 3.7 | — | C65DND315_ | C65DRD315_ |
| | | 575 | 60 | — | 5 | — | 3.7 | — | C65DND315_ | C65DRD315_ |
| 25 | 35 | 115 | 150 | 2 | — | 1.5 | — | 2 | C65DND225_ | C65DRD225_ |
| | | 230 | 150 | 3 | 7-1/2 | 2.2 | 5.5 | 3 | C65DND325_ | C65DRD325_ |
| | | 460 | 125 | — | 10 | — | 7.5 | — | C65DND325_ | C65DRD325_ |
| | | 575 | 100 | — | 10 | — | 7.5 | — | C65DND325_ | C65DRD325_ |
| 30 | 40 | 115 | 180 | 2 | — | 1.5 | — | 2 | C65DND230_ | C65DRD230_ |
| | | 230 | 180 | 5 | 10 | 3.7 | 7.5 | 3 | C65DND330_ | C65DRD330_ |
| | | 460 | 150 | — | 15 | — | 11 | — | C65DND330_ | C65DRD330_ |
| | | 575 | 120 | — | 15 | — | 11 | — | C65DND330_ | C65DRD330_ |
| 40 | 50 | 115 | 240 | 3 | — | 2.2 | — | 2 | C65DNF240_ | C65DRF240_ |
| | | 230 | 240 | 7-1/2 | 10 | 5.5 | 7.5 | 3 | C65DNF340_ | C65DRF340_ |
| | | 460 | 200 | — | 20 | — | 15 | — | C65DNF340_ | C65DRF340_ |
| | | 575 | 160 | — | 20 | — | 15 | — | C65DNF340_ | C65DRF340_ |
| 50 | 65 | 115 | 300 | 3 | — | 2.2 | — | 2 | C65DNJ250_ | C65DRJ250_ |
| | | 230 | 300 | 10 | 15 | 7.5 | 11 | 3 | C65DNJ350_ | C65DRJ350_ |
| | | 460 | 250 | — | 30 | — | 22 | — | C65DNJ350_ | C65DRJ350_ |
| | | 575 | 200 | — | 30 | — | 22 | — | C65DNJ350_ | C65DRJ350_ |
| 60 | 75 | 115 | 360 | 5 | — | 3.7 | — | 2 | C65FNF260_ | — |
| | | 230 | 360 | 10 | 20 | 7.5 | 15 | 3 | C65FNF360_ | — |
| | | 460 | 300 | — | 40 | — | 30 | — | C65FNF360_ | — |
| | | 575 | 240 | — | 40 | — | 30 | — | C65FNF360_ | — |
| 75 | 90 | 115 | 450 | 5 | — | 3.7 | — | 2 | C65FNF275_ | — |
| | | 230 | 450 | 15 | 20 | 11 | 18.5 | 3 | C65FNF375_ | — |
| | | 460 | 375 | — | 50 | — | 37 | — | C65FNF375_ | — |
| | | 575 | 300 | — | 50 | — | 37 | — | C65FNF375_ | — |

Note

^① Incomplete catalog number. Replace underscore (_) with magnet coil suffix from **Page V5-T4-22**.

Magnet Coil Suffix

| Volts 60 Hz | 50 Hz | Coil Suffix ^① |
|----------------------|----------------------|--------------------------|
| 12 | 12 | R |
| 24 | 24 | T |
| 110–120 ^② | 110–120 ^② | A |
| 208–240 | 208–240 | B |
| 240 ^③ | 220 | J |
| 277 | — | H |
| — | 380–415 | L |
| 440–480 | 440–480 | C |
| 550–600 | 550–600 | D |

Magnet Coil Options**Description**

Extra dual quick connect terminals (“U” shaped) for magnet coil terminals.
To order, add Suffix Number **9** to the complete catalog number.
Example: C65DND315A**9**.

Notes

- ① Class H AC coils available as option for 15A–50A contactor.
Add **2** before AC coil suffix letter.
- ② 104–120V 50/60 Hz for 60A, 75A.
- ③ Available through 50A.

25–60A, Single- and Three-Phase—A25, B25



Contents

| Description | Page |
|--|-----------------|
| 25–60A, Single- and Three-Phase—A25, B25 | |
| Product Selection | V5-T4-24 |
| Accessories | V5-T4-26 |
| Technical Data and Specifications | V5-T4-27 |
| Trip Curves | V5-T4-28 |
| Wiring Diagrams | V5-T4-28 |
| Dimensions | V5-T4-29 |
| 15–45A, Single- and Three-Phase—A27, B27 | V5-T4-30 |
| 15–75A, Single- and Three-Phase—A30, B30 and C440/ XT Electronic Overload Relay | V5-T4-38 |

25–60A, Single- and Three-Phase—A25, B25

Product Description

A25 and B25 Definite Purpose Starters from Eaton’s Electrical Sector combine the features and flexibility of the C25 Definite Purpose Contactors and Freedom Series Bi-metallic Ambient Compensated Overload Relays mounted on a common mounting plate.

Features and Benefits

Overload Relay

- Selectable manual or automatic reset operation
- Interchangeable heater packs adjustable $\pm 24\%$ to match motor FLA and calibrated for use with 1.0 and 1.15 service factor motors
- Class 10 or 20 heater packs
- Bimetallic, ambient compensated operated. Trip free mechanism
- Electrically isolated NO-NC contacts (pull RESET button to test)
- Overload trip indication
- Shrouded or fingerproof terminals to reduce possibility of electrical shock
- Single-phase sensitivity

Standards and Certifications

- UL Recognized Components UL File #E-1491, Guide NLDX2
- CSA Certified Components File #LR353, Guide 380W-1.14 Class 3211 04



Catalog Number Selection

25–60A, Single- and Three-Phase—A25, B25



When Ordering Specify

- Catalog number plus magnet coil suffix, see **Page V5-T4-24**
Example, order catalog number **A25CNC30A**
- Heater packs for specific FLA of motor, see **Pages V5-T4-26** and **V5-T4-27**

Product Selection

A25 Starter



Single- and Three-Phase Starters—Open Type

| Ampere Rating | Inductive Full Load | Line Voltage | Locked Rotor | Maximum Motor (hp) | | Maximum Motor (kW) | | Single-Phase ^{①②} | | Three-Phase ^① | |
|---------------|---------------------|--------------|--------------|--------------------|-------------|--------------------|-------------|--|--|--|--|
| | | | | Single-Phase | Three-Phase | Single-Phase | Three-Phase | Common Control Catalog Number ^③ | Separate Control Catalog Number ^③ | Common Control Catalog Number ^③ | Separate Control Catalog Number ^③ |
| 25 | 115 | 150 | 2 | — | 1.5 | — | B25CNC25_ | B25SNC25_ | A25CNC25_ | A25SNC25_ | |
| | 230 | 150 | 3 | 7-1/2 | 2.2 | 5.5 | B25CNC25_ | B25SNC25_ | A25CNC25_ | A25SNC25_ | |
| | 460 | 125 | — | 10 | — | 7.5 | B25CNC25_ | B25SNC25_ | A25CNC25_ | A25SNC25_ | |
| | 575 | 100 | — | 10 | — | 7.5 | B25CNC25_ | B25SNC25_ | A25CNC25_ | A25SNC25_ | |
| 30 | 115 | 180 | 2 | — | 1.5 | — | B25CNC30_ | B25SNC30_ | A25CNC30_ | A25SNC30_ | |
| | 230 | 180 | 5 | 10 | 3.7 | 7.5 | B25CNC30_ | B25SNC30_ | A25CNC30_ | A25SNC30_ | |
| | 460 | 150 | — | 15 | — | 11 | B25CNC30_ | B25SNC30_ | A25CNC30_ | A25SNC30_ | |
| | 575 | 120 | — | 15 | — | 11 | B25CNC30_ | B25SNC30_ | A25CNC30_ | A25SNC30_ | |
| 40 | 115 | 240 | 3 | — | 2.2 | — | B25CNE40_ | B25SNE40_ | A25CNE40_ | A25SNE40_ | |
| | 230 | 240 | 7-1/2 | 10 | 5.5 | 7.5 | B25CNE40_ | B25SNE40_ | A25CNE40_ | A25SNE40_ | |
| | 460 | 200 | — | 20 | — | 15 | B25CNE40_ | B25SNE40_ | A25CNE40_ | A25SNE40_ | |
| | 575 | 160 | — | 20 | — | 15 | B25CNE40_ | B25SNE40_ | A25CNE40_ | A25SNE40_ | |
| 50 | 115 | 300 | — | — | — | — | N/A | N/A | A25CNE50_ | A25SNE50_ | |
| | 230 | 300 | — | 15 | — | 11 | N/A | N/A | A25CNE50_ | A25SNE50_ | |
| | 460 | 250 | — | 30 | — | 22 | N/A | N/A | A25CNE50_ | A25SNE50_ | |
| | 575 | 200 | — | 30 | — | 22 | N/A | N/A | A25CNE50_ | A25SNE50_ | |
| 60 | 115 | 360 | — | — | — | — | N/A | N/A | A25CNE60_ | A25SNE60_ | |
| | 230 | 360 | — | 20 | — | 15 | N/A | N/A | A25CNE60_ | A25SNE60_ | |
| | 460 | 300 | — | 40 | — | 30 | N/A | N/A | A25CNE60_ | A25SNE60_ | |
| | 575 | 240 | — | 40 | — | 30 | N/A | N/A | A25CNE60_ | A25SNE60_ | |

Magnet Coil Suffix

| Voltage 60 Hertz | 50 Hertz | Coil Suffix |
|------------------------|----------------------|-------------|
| AC ^④ | | |
| 12 | 12 | R |
| 24 | 24 | T |
| 110–120 ^⑤ | 110–120 ^⑤ | A |
| 208–240 | 208–240 | B |
| 240 ^⑥ | 220 | J |
| 277 | — | H |
| — | 380–415 | L |
| 440–480 | 440–480 | C |
| 550–600 | 550–600 | D |

| Voltage 60 Hertz | Coil Suffix |
|------------------------|-------------|
| DC ^⑦ | |
| 12 | 1R |
| 24 | 1T |
| 48 | 1W |
| 120 | 1A |

Notes

- ① Starters do not include heater packs. Select heater pack from tables, see **Pages V5-T4-26 and V5-T4-27**.
- ② Set of three heater packs required for single-phase applications.
- ③ Incomplete catalog number. Replace underscore (_) with magnet coil suffix from table above.
- ④ Class H AC coils available as option for 15A–50A contactor. Add **2** before AC coil suffix letter.
- ⑤ 104–120V 50/60 Hz for 60A contactor.
- ⑥ Available through 50A.
- ⑦ Starters with DC coils include an early breaking auxiliary contact, C320KGD1. See **Page V5-T4-62** for more detail.

Overload Relay

General

Overload relays are provided to protect motors, motor control apparatus and motor-branch circuit conductors against excessive heating due to motor overloads and failure to start. This definition does not include: 1) motor circuits over 600 volts, 2) short-circuits, 3) ground faults and 4) fire pump control. (NEC Art. 430-31)

Time Current Characteristics

The time-current characteristics of an overload relay is an expression of performance which defines its operating time at various multiples of its current setting. Tests are run at Underwriters Laboratory (UL) in accordance with NEMA Standards and the NEC.

UL requires—

- When tested at 100 percent of its current rating, the overload relay shall trip ultimately
- When tested at 200 percent of its current rating, the overload relay shall trip in not more than 8 minutes
- When tested at 600 percent of its current rating, the overload relay shall trip in not more than 10 or 20 seconds, depending on the Class of the relay or heater packs

“Current Rating” is defined as the minimum current at which the relay will trip. Per NEC, an overload must ultimately trip at 125% of FLA (Full Load Amperes) current (heater) setting for a 1.15 service factor motor and 115% FLA for a 1.0 service

factor motor. “Current Setting” is defined as the FLA of the motor and thus the overload heater pack setting.

Example: 600% of current rating is defined as 750% (600 x 1.25) of FLA current (heater) setting for a 1.15 service factor motor. A 10 ampere heater setting must trip in 20 seconds or less at 75 amperes motor current for a Class 20 relay.

Overload Relay Setting

FLA Dial Adjustment—

For motors having a 1.15 service factor, rotate the FLA adjustment dial to correspond to the motor’s FLA rating. Estimate the dial position when the motor FLA falls between two letter values as shown in the example.

For motors having a 1.0 service factor, rotate the FLA dial single-half position counterclockwise (CCW).

Manual/Automatic Reset—

The overload relay is factory set at M for manual reset operation. For automatic reset operation, turn the reset adjustment dial to the A position as shown in the illustration.

Automatic reset is not intended for two-wire control devices.

Test for Trip Indication—

To test overload relay for trip indication when in manual reset, pull out the blue RESET button. An orange flag will appear indicating that the device has tripped. Push RESET button in to reset.

FLA Dial Adjustment

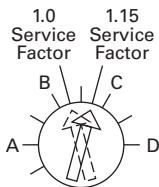

Example of 12.0 FLA setting for heater pack number H2011B showing position for 1.0 or 1.15 service factor motors.

Reset Adjustment Dial

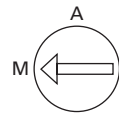

Example of setting for manual reset.

Replacement Overload with Connectors

| Starter Size | Overload Part Number |
|--------------|----------------------|
| 25 and 30A | 10-7125 |
| 40 and 50A | 10-7132 |
| 60A | 10-7131 |

Accessories

Contactors Accessories, see **Pages V5-T4-11** and **V5-T4-12**.

Locking Cover for Overload Relay

Snap-on transparent or opaque plastic panel for covering access port to the overload relay trip setting dial—helps prevent accidental or unauthorized changes to trip and reset setting.

4

Locking Cover

Locking Cover for Overload Relay



| Description | Minimum Order Quantity (Std. Pkg.) | Catalog Number |
|--|------------------------------------|----------------|
| Clear cover, no accessibility | 50 | C320PC3 |
| Gray cover, no accessibility, with auto only nib | 50 | C320PC4 |
| Gray cover, no accessibility, with manual only nib | 50 | C320PC5 |
| Gray cover with FLA dial accessibility, A, B, C, D positions and auto only nib | 50 | C320PC6 |
| Gray cover with FLA dial accessibility, A, B, C, D positions and manual only nib | 50 | C320PC7 |

Separate Enclosures

Separate Enclosures—NEMA 1

| Application | Catalog Number |
|----------------|----------------|
| 25 and 30A | C799B11 |
| 40, 50 and 60A | C799B13 |

Heater Packs

Fast Trip—Class 10 Heater Packs

Manual or Automatic Reset

Heater packs are shipped three to a carton.

Catalog numbers listed below are for three heater packs.

Fast Trip Ratings

| Motor Full Load Ampere Rating ^① | | | | Catalog Number ^② (Includes Three Heater Packs) |
|--|-------|-------|-------|--|
| Dial Position | A | B | C | |
| | 0.26 | 0.313 | 0.367 | H2101B-3 |
| | 0.384 | 0.464 | 0.543 | H2102B-3 |
| | 0.57 | 0.688 | 0.806 | H2103B-3 |
| | 0.846 | 1.02 | 1.2 | H2104B-3 |
| | 1.28 | 1.55 | 1.83 | H2105B-3 |
| | 1.92 | 2.33 | 2.74 | H2106B-3 |
| | 2.3 | 2.79 | 3.28 | H2107B-3 |
| | 3.38 | 4.1 | 4.82 | H2108B-3 |
| | 4.96 | 6.03 | 7.09 | H2109B-3 |
| | 7.07 | 8.58 | 10.1 | H2110B-3 |
| | 9.6 | 11.2 | 12.8 | H2111B-3 |
| | 14.4 | 17.5 | 20.7 | H2112B-3 |
| | 18.7 | 21.8 | 25 | H2113B-3 |
| | 23.5 | 27.3 | 31 | H2114B-3 |
| | 28.3 | 32.6 | 37 | H2115B-3 |
| | 36.6 | 42.3 | 48.1 | H2116B-3 |
| | 53.8 | 60.8 | 67.9 | H2117B-3 |

Trip Curves, see **Page V5-T4-28**.

Notes

- ① For motor full load amperes between listed values, adjust dial clockwise for higher or counter-clockwise for lower motor currents. The currents listed are for 1.5 service factor motors. A position adjustment is provided for 1.0 service factor motors.
- ② Set of three heater packs are required for both single- and three-phase applications.

Standard Trip—Class 20 Heater Packs

Manual or Automatic Reset

Heater packs are shipped three to a carton.

Catalog numbers listed below are for three heater packs.

Standard Trip Ratings

| Motor Full Load Ampere Rating ^① | | | | Catalog Number ^② (Includes Three Heater Packs) |
|--|-------|-------|-------|--|
| Dial Position | | | | |
| A | B | C | D | |
| 0.254 | 0.306 | 0.359 | 0.411 | H2001B-3 |
| 0.375 | 0.452 | 0.53 | 0.607 | H2002B-3 |
| 0.56 | 0.676 | 0.791 | 0.907 | H2003B-3 |
| 0.814 | 0.983 | 1.15 | 1.32 | H2004B-3 |
| 1.2 | 1.45 | 1.71 | 1.96 | H2005B-3 |
| 1.79 | 2.16 | 2.53 | 2.9 | H2006B-3 |
| 2.15 | 2.6 | 3.04 | 3.49 | H2007B-3 |
| 3.23 | 3.9 | 4.56 | 5.23 | H2008B-3 |
| 4.55 | 5.5 | 6.45 | 7.4 | H2009B-3 |
| 6.75 | 8.17 | 9.58 | 11 | H2010B-3 |
| 9.14 | 10.8 | 12.4 | 14 | H2011B-3 |
| 14 | 16.9 | 19.9 | 22.8 | H2012B-3 |
| 18.7 | 22.7 | 26.7 | 30.7 | H2013B-3 |
| 23.5 | 28.5 | 33.5 | 38.5 | H2014B-3 |
| 29 | 34 | 39.1 | 44.1 | H2015B-3 |
| 39.6 | 45.5 | 51.5 | 57.4 | H2016B-3 |
| 53.9 | 60.9 | 67.9 | 74.9 | H2017B-3 |

Trip Curves, see Page V5-T4-28.

Technical Data and Specifications

Terminal Wire Sizes

| Terminal Type | Wire Range—Solid or Stranded | |
|----------------------|------------------------------|----------------|
| | Power Terminals | Coil Terminals |
| Screw/pressure plate | 8–14 AWG | 12–16 AWG |
| Box lug: 25–50A | 4–14 AWG | 12–16 AWG |
| Box lug: 60A | 3–14 AWG | 12–16 AWG |

Power Terminals—Load—Cu Only (Stranded or Solid)

| Terminal | Range | Torque Rating |
|----------------|----------|--|
| 25 and 30A | 14–6 AWG | 20 lb-in (14–10 AWG) |
| 40, 50 and 60A | 14–2 AWG | 35 lb-in (14–10 AWG) 40 lb-in (8 AWG) 45 lb-in (6–4 AWG) 50 lb-in (3–2 AWG) |

Control Terminals—Cu Only

12–16 AWG stranded, 12–14 AWG solid

Notes

- ① For motor full load amperes between listed values, adjust dial clockwise for higher or counter-clockwise for lower motor currents. The currents listed are for 1.5 service factor motors. A position adjustment is provided for 1.0 service factor motors.
- ② Set of three heater packs are required for both single- and three-phase applications.
- ③ Line side (contactor) torque ratings can be found on Page V5-T4-14.

4.3

Definite Purpose Contactors and Starters

Starters

4

Overload Relay UL/CSA Contact Ratings Control Circuit

| AC Volts | 120V | 240V | 480V | 600V |
|------------------------|------|-------|--------|------|
| NC Contact B600 | | | | |
| Make and break | 30A | 15A | 7.5A | 6A |
| Break | 3A | 1.5A | 0.75A | 0.6A |
| Continuous | 5A | 5A | 5A | 5A |
| NO Contact C600 | | | | |
| Make and break | 15A | 7.5A | 3.375A | 3A |
| Break | 1.5A | 0.75A | 0.375A | 0.3A |
| Continuous | 2.5A | 2.5A | 2.5A | 2.5A |

Trip Curves

Bimetallic Ambient Compensated Overload Relay—25°C Open Rating

Class 10 Overload Relay

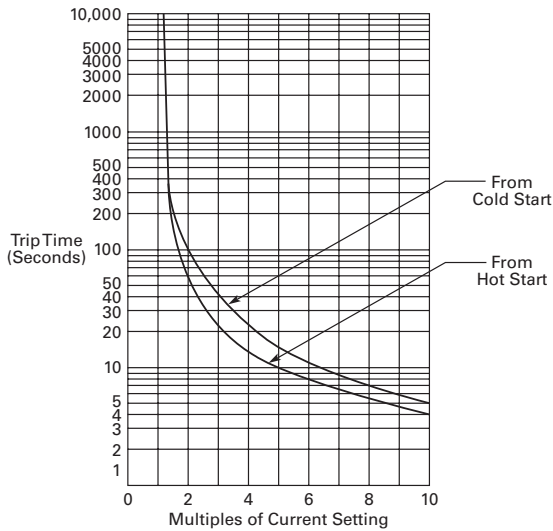

Class 20 Overload Relay

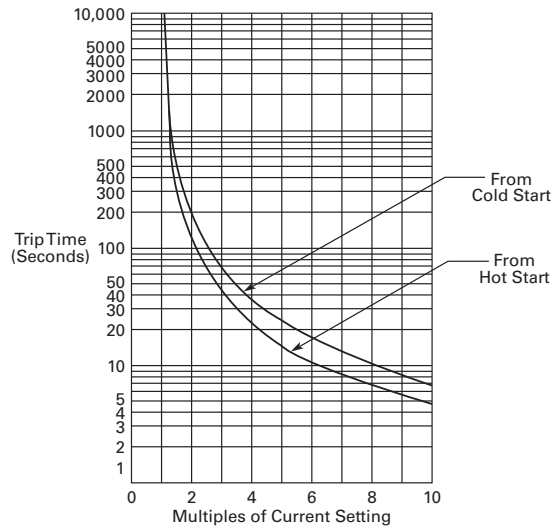

Wiring Diagrams

Single-Phase Connections

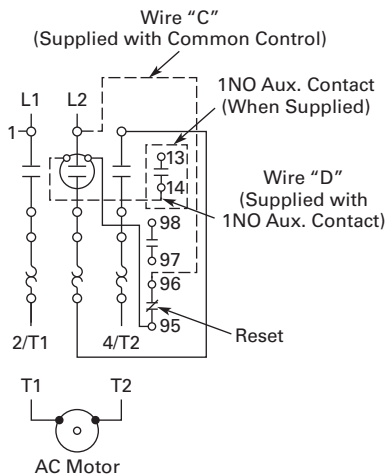

Three-Phase Connections

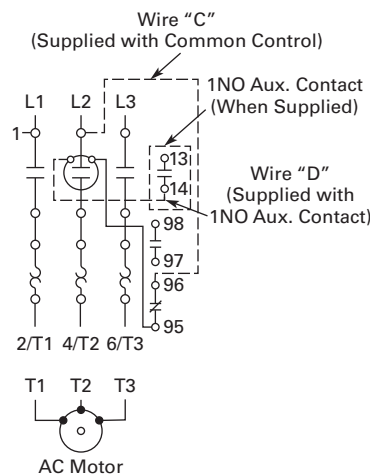

Dimensions

Approximate Dimensions in Inches (mm)

A25 and B25 Starters—Open Type

25 and 30 Ampere

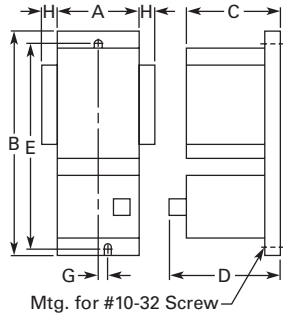

40, 50 and 60 Ampere

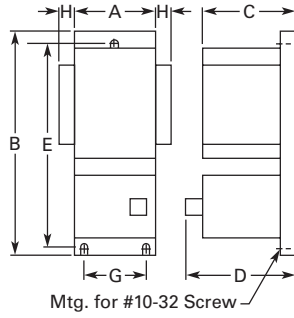

Dimensions and Shipping Weights

| Ampere Size | Wide A | High B | Deep C | Deep D | Mounting E | Mounting G | Auxiliary Contact Adder H | Shipping Weight Lbs (kg) |
|-------------|-------------|--------------|--------------|-------------|---------------|---------------|---------------------------------|--------------------------------|
| 25 and 30 | 2.50 (64.0) | 7.14 (181.0) | 3.56 (90.4) | 3.69 (93.7) | 6.55 (166.0) | 0.20 (5.1) | 0.54 (13.7) | 1.8 (0.8) |
| 40 | 2.56 (65.0) | 8.08 (205.0) | 3.50 (89.0) | 3.66 (93.0) | 7.50 (190.5) | 2.00 (51.0) | 0.54 (13.7) | 1.8 (0.8) |
| 50 and 60 | 2.56 (65.0) | 8.08 (205.0) | 4.15 (105.0) | 3.66 (93.0) | 7.50 (190.5) | 2.00 (51.0) | 0.54 (13.7) | 3.6 (1.6) |

15–45A, Single- and Three-Phase—A27, B27



15–45A, Single- and Three-Phase—A27, B27

Product Description

A27 and B27 Definite Purpose Starters from Eaton’s Electrical Sector combine the features and flexibility of the C25 Definite Purpose Contactors and **XT** Series Bi-metallic Ambient Compensated Overload Relays.

Features and Benefits

- Selectable manual or automatic reset operation
- Class 10 trip class
- Bimetallic, ambient compensated operated. Trip free mechanism
- Electrically isolated NO-NC contacts (pull TEST button to test)
- Shrouded or fingerproof terminals to reduce possibility of electrical shock
- Single-phase sensitivity

Contents

Description

| <i>Description</i> | <i>Page</i> |
|--|-----------------|
| 25–60A, Single- and Three-Phase—A25, B25 | V5-T4-23 |
| 15–45A, Single- and Three-Phase—A27, B27 | |
| Product Selection | V5-T4-31 |
| Renewal Parts | V5-T4-33 |
| Technical Data and Specifications | V5-T4-33 |
| Trip Curve | V5-T4-36 |
| Wiring Diagrams | V5-T4-36 |
| Dimensions | V5-T4-37 |
| 15–75A, Single- and Three-Phase—A30, B30 and C440/ XT Electronic Overload Relay | V5-T4-38 |

Standards and Certifications

- UL Recognized Components UL File #E-1491, Guide NLDX2
- CSA Certified Components File #LR353, Guide 3 80W-1.14 Class 3211 04
- IEC/EN 60947
- VDE 0660
- UL
- CSA
- CE



Catalog Number Selection

15–45A, Single- and Three-Phase—A27, B27

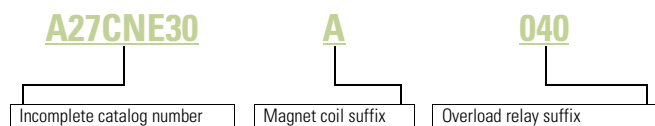

When Ordering Specify

- Catalog number plus magnet coil suffix plus overload relay suffix, see **Page V5-T4-32**
Example, order catalog number **A27CNE30A040**

Product Selection

A27 Starter



Three-Phase Starter—Open Type

| Ampere Rating | | | | | Common Control | | Separate Control | |
|---------------------|--------------|--------------|--------------------|--------------------|---------------------------------------|-----------------------------------|---------------------------------------|-----------------------------------|
| Inductive Full Load | Line Voltage | Locked Rotor | Maximum Motor (hp) | Maximum Motor (kW) | Metal Mounting Plate Catalog Number ① | DIN Rail Adapter Catalog Number ① | Metal Mounting Plate Catalog Number ① | DIN Rail Adapter Catalog Number ① |
| 15 | 115 | 90 | — | — | A27CNC15_ | A27CRC15_ | A27SNC15_ | A27SRC15_ |
| | 230 | 90 | 3 | 2.2 | A27CNC15_ | A27CRC15_ | A27SNC15_ | A27SRC15_ |
| | 460 | 75 | 5 | 3.7 | A27CNC15_ | A27CRC15_ | A27SNC15_ | A27SRC15_ |
| | 575 | 60 | 5 | 3.7 | A27CNC15_ | A27CRC15_ | A27SNC15_ | A27SRC15_ |
| 25 | 115 | 150 | — | — | A27CNC25_ | A27CRC25_ | A27SNC25_ | A27SRC25_ |
| | 230 | 150 | 7-1/2 | 5.5 | A27CNC25_ | A27CRC25_ | A27SNC25_ | A27SRC25_ |
| | 460 | 125 | 10 | 7.5 | A27CNC25_ | A27CRC25_ | A27SNC25_ | A27SRC25_ |
| | 575 | 100 | 10 | 7.5 | A27CNC25_ | A27CRC25_ | A27SNC25_ | A27SRC25_ |
| 30 | 115 | 180 | — | — | A27CNE30_ | A27CRE30_ | A27SNE30_ | A27SRE30_ |
| | 230 | 180 | 10 | 7.5 | A27CNE30_ | A27CRE30_ | A27SNE30_ | A27SRE30_ |
| | 460 | 150 | 15 | 11 | A27CNE30_ | A27CRE30_ | A27SNE30_ | A27SRE30_ |
| | 575 | 120 | 15 | 11 | A27CNE30_ | A27CRE30_ | A27SNE30_ | A27SRE30_ |
| 40 | 115 | 240 | — | — | A27CNE40_ | A27CRE40_ | A27SNE40_ | A27SRE40_ |
| | 230 | 240 | 10 | 7.5 | A27CNE40_ | A27CRE40_ | A27SNE40_ | A27SRE40_ |
| | 460 | 200 | 20 | 15 | A27CNE40_ | A27CRE40_ | A27SNE40_ | A27SRE40_ |
| | 575 | 160 | 20 | 15 | A27CNE40_ | A27CRE40_ | A27SNE40_ | A27SRE40_ |
| 45 | 115 | 270 | — | — | A27CNE45_ | A27CRE45_ | A27SNE45_ | A27SRE45_ |
| | 230 | 270 | 15 | 11 | A27CNE45_ | A27CRE45_ | A27SNE45_ | A27SRE45_ |
| | 460 | 225 | 30 | 22 | A27CNE45_ | A27CRE45_ | A27SNE45_ | A27SRE45_ |
| | 575 | 180 | 30 | 22 | A27CNE45_ | A27CRE45_ | A27SNE45_ | A27SRE45_ |

Note

① Incomplete catalog number. Replace underscore (_) with magnet coil suffix and overload relay suffix from **Page V5-T4-32**.

Single-Phase Starter—Open Type, B27

| Ampere Rating | | | | | Common Control | | Separate Control | |
|---------------------|--------------|--------------|--------------------|--------------------|---------------------------------------|-----------------------------------|---------------------------------------|-----------------------------------|
| Inductive Full Load | Line Voltage | Locked Rotor | Maximum Motor (hp) | Maximum Motor (kW) | Metal Mounting Plate Catalog Number ① | DIN Rail Adapter Catalog Number ① | Metal Mounting Plate Catalog Number ① | DIN Rail Adapter Catalog Number ① |
| 15 | 115 | 90 | 3/4 | 0.4 | B27CNC15_ | B27CRC15_ | B27SNC15_ | B27SRC15_ |
| | 230 | 90 | 2 | 1.5 | B27CNC15_ | B27CRC15_ | B27SNC15_ | B27SRC15_ |
| | 460 | 75 | — | — | B27CNC15_ | B27CRC15_ | B27SNC15_ | B27SRC15_ |
| | 575 | 60 | — | — | B27CNC15_ | B27CRC15_ | B27SNC15_ | B27SRC15_ |
| 25 | 115 | 150 | 2 | 1.5 | B27CNC25_ | B27CRC25_ | B27SNC25_ | B27SRC25_ |
| | 230 | 150 | 3 | 2.2 | B27CNC25_ | B27CRC25_ | B27SNC25_ | B27SRC25_ |
| | 460 | 125 | — | — | B27CNC25_ | B27CRC25_ | B27SNC25_ | B27SRC25_ |
| | 575 | 100 | — | — | B27CNC25_ | B27CRC25_ | B27SNC25_ | B27SRC25_ |
| 30 | 115 | 180 | 2 | 1.5 | B27CNE30_ | B27CRE30_ | B27SNE30_ | B27SRE30_ |
| | 230 | 180 | 5 | 3.7 | B27CNE30_ | B27CRE30_ | B27SNE30_ | B27SRE30_ |
| | 460 | 150 | — | — | B27CNE30_ | B27CRE30_ | B27SNE30_ | B27SRE30_ |
| | 575 | 120 | — | — | B27CNE30_ | B27CRE30_ | B27SNE30_ | B27SRE30_ |
| 40 | 115 | 240 | 3 | 2.2 | B27CNE40_ | B27CRE40_ | B27SNE40_ | B27SRE40_ |
| | 230 | 240 | 7-1/2 | 5.5 | B27CNE40_ | B27CRE40_ | B27SNE40_ | B27SRE40_ |
| | 460 | 200 | — | — | B27CNE40_ | B27CRE40_ | B27SNE40_ | B27SRE40_ |
| | 575 | 160 | — | — | B27CNE40_ | B27CRE40_ | B27SNE40_ | B27SRE40_ |
| 45 | 115 | 270 | 3 | 2.2 | B27CNE45_ | B27CRE45_ | B27SNE45_ | B27SRE45_ |
| | 230 | 270 | 7-1/2 | 7.5 | B27CNE45_ | B27CRE45_ | B27SNE45_ | B27SRE45_ |
| | 460 | 225 | — | — | B27CNE45_ | B27CRE45_ | B27SNE45_ | B27SRE45_ |
| | 575 | 180 | — | — | B27CNE45_ | B27CRE45_ | B27SNE45_ | B27SRE45_ |

Magnet Coil Suffix

| Voltage 60 Hertz | 50 Hertz | Coil Suffix | Voltage 60 Hertz | Coil Suffix |
|------------------|----------|-------------|------------------|-------------|
| AC ② | | | DC ④ | |
| 12 | 12 | R | 12 | 1R |
| 24 | 24 | T | 24 | 1T |
| 110–120 | 110–120 | A | 48 | 1W |
| 208–240 | 208–240 | B | 120 | 1A |
| 240 ③ | 220 | J | | |
| 277 | — | H | | |
| — | 380–415 | L | | |
| 440–480 | 440–480 | C | | |
| 550–600 | 550–600 | D | | |

Overload Relay Suffix

| Motor Full Load Amperes | Suffix Code | For use with Contactor Ampere Range |
|-------------------------|-------------|-------------------------------------|
| Frame C | | |
| 0.1–0.16 | P16 | 15–25A |
| 0.16–0.24 | P24 | 15–25A |
| 0.24–0.4 | P40 | 15–25A |
| 0.4–0.6 | P60 | 15–25A |
| 0.6–1 | 001 | 15–25A |
| 1–1.6 | 1P6 | 15–25A |
| 1.6–2.4 | 2P4 | 15–25A |
| 2.4–4 | 004 | 15–25A |
| 4–6 | 006 | 15–25A |
| 6–10 | 010 | 15–25A |
| 10–16 | 016 | 15–25A |
| 16–24 | 024 | 15–25A |
| 24–32 | 032 | 15–25A |
| Frame D | | |
| 6–10 | 010 | 30–45A |
| 10–16 | 016 | 30–45A |
| 16–24 | 024 | 30–45A |
| 24–40 | 040 | 30–45A |
| 40–57 | 057 | 30–45A |

Notes

- ① Incomplete catalog number. Replace underscore (_) with magnet coil suffix and overload relay suffix from tables above.
- ② Class H AC coils available as option. Add **2** before AC coil suffix letter.
- ③ Available through 45A.
- ④ Starters with DC coils include an early breaking auxiliary contact, C320KGD1. See **Page V5-T4-62** for more detail.

Renewal Parts

Overload Relays

| Motor Full Load Amperes | Suffix Code | For use with Contactor Ampere Range | Overload Relay Catalog Number |
|-------------------------|-------------|-------------------------------------|-------------------------------|
| Frame C | | | |
| 0.1–0.16 | P16 | 15–25A | XTOBP16CC1DP |
| 0.16–0.24 | P24 | 15–25A | XTOBP24CC1DP |
| 0.24–0.4 | P40 | 15–25A | XTOBP40CC1DP |
| 0.4–0.6 | P60 | 15–25A | XTOBP60CC1DP |
| 0.6–1 | 001 | 15–25A | XTOB001CC1DP |
| 1–1.6 | 1P6 | 15–25A | XTOB1P6CC1DP |
| 1.6–2.4 | 2P4 | 15–25A | XTOB2P4CC1DP |
| 2.4–4 | 004 | 15–25A | XTOB004CC1DP |
| 4–6 | 006 | 15–25A | XTOB006CC1DP |
| 6–10 | 010 | 15–25A | XTOB010CC1DP |
| 10–16 | 016 | 15–25A | XTOB016CC1DP |
| 16–24 | 024 | 15–25A | XTOB024CC1DP |
| 24–32 | 032 | 15–25A | XTOB032CC1DP |
| Frame D | | | |
| 6–10 | 010 | 30–45A | XTOB010DC1DP |
| 10–16 | 016 | 30–45A | XTOB016DC1DP |
| 16–24 | 024 | 30–45A | XTOB024DC1DP |
| 24–40 | 040 | 30–45A | XTOB040DC1DP |
| 40–57 | 057 | 30–45A | XTOB057DC1DP |

Technical Data and Specifications

Terminal Wire Sizes

| Line Side (Contactor) ① | Wire Range—Solid or Stranded | |
|-------------------------|------------------------------|----------------|
| | Power Terminals | Coil Terminals |
| Terminal Type | | |
| Screw/pressure plate | 8–14 AWG | 12–16 AWG |
| Box lug: 15–45A | 4–14 AWG | 12–16 AWG |

Power Terminals—Load—Cu Only (Stranded or Solid)

| Terminal | Range | Torque Rating |
|----------------|----------|---------------------|
| 15 and 25A | 14–8 AWG | 16 lb-in (14–8 AWG) |
| 30, 40 and 45A | 14–2 AWG | 31 lb-in (14–2 AWG) |

Control Terminals—Cu Only

12–16 AWG stranded, 12–14 AWG solid

Note

① Line side (contactor) torque ratings can be found on **Page V5-T4-14**.

Overload Relays

These tripping characteristics are the mean values of the spread at 20°C ambient temperature in a cold state.

Tripping time depends on response current. With devices at operating temperature, the tripping time of the overload relay reduces to approximately 25% of the read off value. Specific characteristics for each individual setting range can be found in MN03402001E.

Overload Relays

| Description | XTOB ... CC1 Specification | XTOB ... DC1 Specification |
|--|--|--|
| General | | |
| Climatic proofing | Damp heat, constant, to IEC 60068-2-78; Damp heat, cyclic, to IEC 60 068-2-30 | Damp heat, constant, to IEC 60068-2-78; Damp heat, cyclic, to IEC 60 068-2-30 |
| Ambient temperature range ① | –25° to 50°C [–13° to 122°F] | –25° to 50°C [–13° to 122°F] |
| Temperature compensation | Continuous | Continuous |
| Mechanical shock resistance (IEC/EN 60068-2-27) | | |
| Half-sinusoidal shock 10 ms | 10g | 10g |
| Degree of protection | IP20 | IP20 |
| Protection against direct contact when actuated from front (IEC 536) | Finger and back of hand proof | Finger and back of hand proof |
| Insulation voltage (U _i) Vac | 690 | 690 |
| Overvoltage category/pollution degree | III/3 | III/3 |
| Impulse withstand voltage (U _{imp}) Vac | 6000 | 6000 |
| Operational voltage (U _e) Vac | 690 | 690 |
| Safe isolation to VDE 0106 Part 101 and Part 101/A1 | | |
| Between auxiliary contacts and main contacts (Vac) | 440 | 440 |
| Between main contacts (Vac) | 440 | 440 |
| Overload relay setting range | 0.1–32A | 6–75A |
| Temperature compensation residual error >20°C (%/K) | ≤0.25 | ≤0.25 |
| Current heat loss (3 conductors) | | |
| Lower value of setting range, W | 2.5 | 3 |
| Upper value of setting range, W | 6 | 7.5 |
| Terminal capacity | 2 x (1–6) | 2 x (1–6) |
| Solid, mm ² | 2 x (1–4) | 1 x 25 |
| Flexible with ferrule, mm ² | 2 x (1–6) ② | 2 x (1–10) ③ |
| Solid or stranded, AWG | 14-8 | 14-2 |
| Terminal screw | M4 | M6 |
| Tightening torque Nm (lb-in) | 1.8 (16) | 3.5 (31) |
| Tools | | |
| Pozidrive screwdriver | Size 2 | Size 2 |
| Standard screwdriver | 1 x 6 | 1 x 6 |

Notes

① Ambient temperature operating range to IEC/EN 60947, PTB: –5° to 50°C [23° to 122°F].

② 6 mm² flexible with ferrules to DIN 46228.

③ Main contact terminal capacity, solid and stranded conductors with ferrules: When using two conductors use identical cross-section.

Overload Relays, continued

| Description | XTOB ... CC1 Specification | XTOB ... DC1 Specification |
|---|-------------------------------|-------------------------------|
| Auxiliary and Control Circuit Connections | | |
| Impulse withstand voltage (U_{imp}) Vac | 6000 | 6000 |
| Overtoltage category/pollution degree | III/3 | III/3 |
| Terminal capacity | | |
| Solid, mm ² | 2 x (0.75–4) | 2 x (0.75–4) |
| Flexible with ferrule, mm ² | 2 x (0.75–2.5) | 2 x (0.75–2.5) |
| Solid or stranded, AWG | 2 x (18–12) | 2 x (18–12) |
| Terminal screw | M3.5 | M3.5 |
| Tightening torque Nm (lb-in) | 0.8–1.3 (7–11.5) | 0.8–1.3 (7–11.5) |
| Tools | | |
| Pozidrive screwdriver | Size 2 | Size 2 |
| Standard screwdriver | 1 x 6 | 1 x 6 |
| Auxiliary circuit rated insulation voltage (U_j) Vac | 500 | 500 |
| Rated operational voltage (U_e) Vac | 500 | 500 |
| Safe isolation to VDE 0106 Part 101 and Part 101/A1 Between the auxiliary contacts (Vac) | 240 | 240 |
| Conventional thermal current, I_{th} | 6 | 6 |
| Rated operational current—AC-15 | | |
| NO contact | | |
| 120V | 1.5 | 1.5 |
| 240V | 1.5 | 1.5 |
| 415V | 0.5 | 0.5 |
| 500V | 0.5 | 0.5 |
| NC contact | | |
| 120V | 1.5 | 1.5 |
| 240V | 1.5 | 1.5 |
| 415V | 0.9 | 0.9 |
| 500V | 0.8 | 0.8 |
| Rated operational current—DC-13 L/R ≤15 ms ^① | | |
| NO contact | | |
| 24V | 0.9 | 0.9 |
| 60V | 0.75 | 0.75 |
| 110V | 0.4 | 0.4 |
| 220V | 0.2 | 0.2 |
| Short-circuit rating without welding maximum fuse, A gG/gL | 6 | 6 |

Note

^① Rated operational current: Making and breaking conditions to DC-13, L/R constant as stated.

4.3

Definite Purpose Contactors and Starters

Starters

Trip Curve

Overload Relay

4

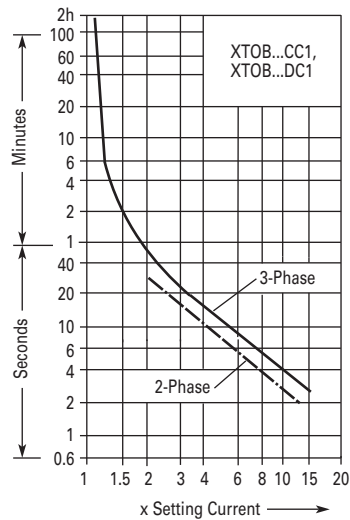

Wiring Diagrams

Single-Phase Connections

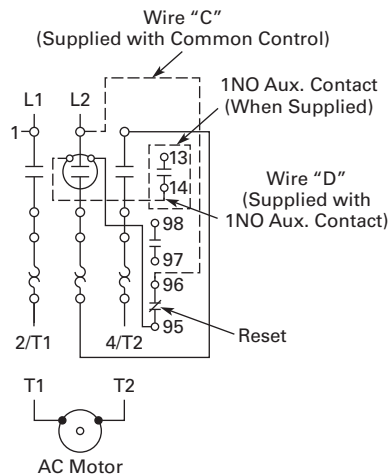

Three-Phase Connections

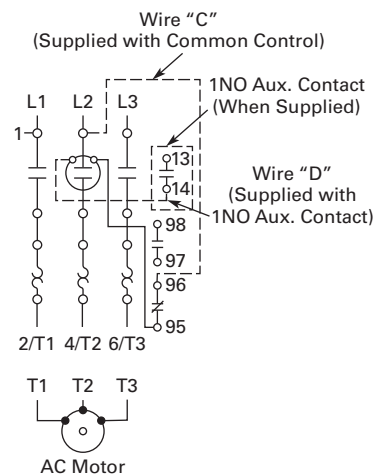

Dimensions

Approximate Dimensions in Inches (mm)

A27 and B27 Starters—Open Type

15 and 25 Ampere

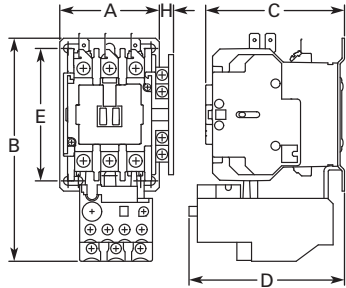

30, 40 and 45 Ampere

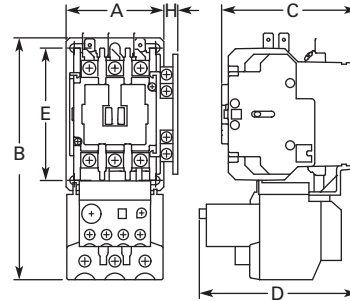

Dimensions and Shipping Weights

| Ampere Size | Wide A | High B | Deep C | Deep D | Mounting E | Mounting G | Auxiliary Contact Adder H | Shipping Weight Lbs (kg) |
|--------------------------------|-------------|--------------|-------------|-------------|---------------|---------------|---------------------------------|-----------------------------|
| 15 and 25 (metal plate) | 2.40 (61.0) | 5.50 (139.0) | 3.35 (85.0) | 3.70 (94.0) | 3.13 (82.6) | — | 0.54 (13.7) | 1.6 (0.7) |
| 15 and 25 (DIN rail mount) | 2.23 (56.5) | 5.20 (133.0) | 3.35 (85.0) | 3.70 (94.0) | — | — | 0.54 (13.7) | 1.6 (0.7) |
| 30, 40 and 45 (metal plate) | 2.40 (61.0) | 6.00 (152.0) | 3.35 (85.0) | 3.90 (98.0) | 3.13 (82.6) | — | 0.54 (13.7) | 1.11 (0.9) |
| 30, 40 and 45 (DIN rail mount) | 2.23 (56.5) | 5.70 (145.0) | 3.35 (85.0) | 3.90 (98.0) | — | — | 0.54 (13.7) | 1.11 (0.9) |

15-75A, Single- and Three-Phase—A30, B30 and C440/XT Electronic Overload Relay



Contents

| <i>Description</i> | <i>Page</i> |
|--|-----------------|
| 25-60A, Single- and Three-Phase—A25, B25 | V5-T4-23 |
| 15-45A, Single- and Three-Phase—A27, B27 | V5-T4-30 |
| 15-75A, Single- and Three-Phase—A30, B30 and C440/XT Electronic Overload Relay | |
| Standards and Certifications | V5-T4-39 |
| Catalog Number Selection | V5-T4-39 |
| Product Selection | V5-T4-40 |
| Accessories | V5-T4-42 |
| Technical Data and Specifications | V5-T4-43 |
| Wiring Diagrams | V5-T4-45 |

15-75A, Single- and Three-Phase—A30, B30 and C440/XT Electronic Overload Relay

Product Description

A30 and B30 Starters

A30 and B30 Definite Purpose Starters from Eaton’s Electrical Sector combine the features and flexibility of the C25 Definite Purpose Contactors and C440 Electronic Overload Relays.

C440 Overload

C440 is the most compact, high-featured, economical product in its class.

C440 is a self-powered electronic overload relay available up to 100A as a self contained unit. With external CTs, C440 can protect motor up to 1500 FLA. Available add-on accessories include remote reset capability and communication modules with I/O for DeviceNet, PROFIBUS, and Modbus.

Features

A30 and B30 Starters

- Standard version: selectable trip class (10A, 10, 20, 30) with selectable manual or auto reset
- Current adjustment range: 5:1
- Self-powered design—will accept AC voltages from 12 to 690V 50/60 Hz
- Ambient temperature compensation
- Low heat generation
- Phase loss protection
- Phase unbalance protection
- Electrically isolated 1NO-1NC contacts (push-to-test)
- Trip status indicator

C440 Overload

- Reliable, accurate, electronic motor protection
- Easy to select, install and maintain
- Compact size
- Flexible, intelligent design
- Global product offering—available with NEMA, IEC and DP power control

Motor Control

- Two B600 alarm (NO) and fault (NC) contacts
- Test/Trip button

Motor Protection

- Thermal overload
- Phase loss
- Selectable (ON/OFF) phase unbalance
- Selectable (ON/OFF) ground fault

User Interface

- Large FLA selection dial
- Trip status indicator
- Operating mode LED
- DIP switch selectable trip class, phase unbalance and ground fault
- Selectable Auto/Manual reset

Feature Options

- Remote reset
 - 120 Vac
 - 24 Vac
 - 24 Vdc
- Tamper-proof cover

Standards and Certifications

A30 and B30 Starters

- UL Listed Components
- CSA Certified Components
- IEC EN 60947-4-1, EN 60947-5-1
- CE Certified Components
- CCC Certified Components
- RoHS Certified Components



Catalog Number Selection

A30 and B30 Definite Purpose Starters

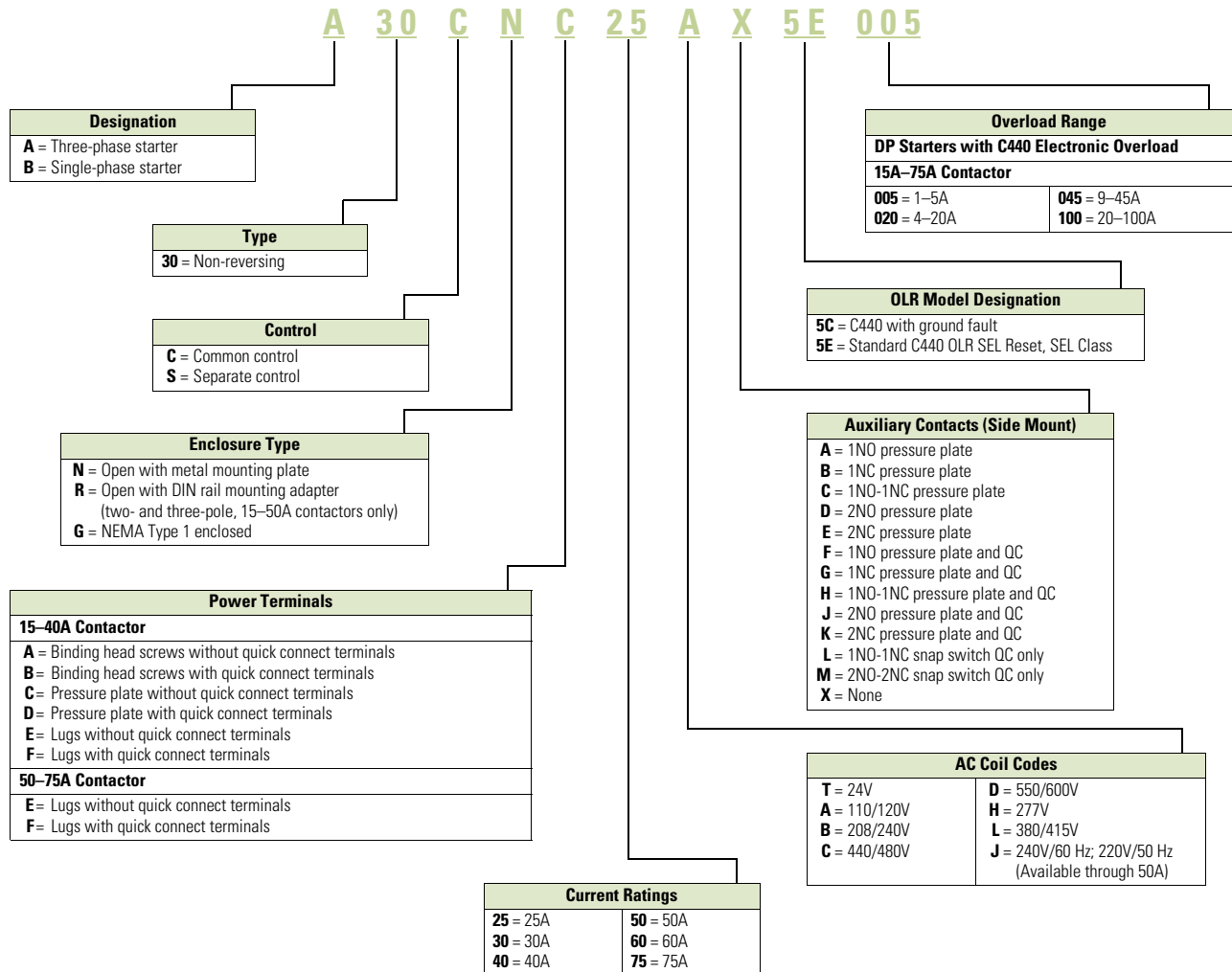

4.3

Definite Purpose Contactors and Starters

Starters

Product Selection

When Ordering Specify

- Catalog number plus AC coil code, auxiliary contact code, OLR model designation and overload range code, see below

4

A30 Starter



Three-Phase Starters—Open Type A30 with C440 Electronic Overload

| Inductive Full Load | Line Voltage | Locked Rotor | Maximum Motor (hp) | Maximum Motor (kW) | Common Control | | Separate Control | |
|---------------------|--------------|--------------|--------------------|--------------------|---------------------------------------|-----------------------------------|---------------------------------------|-----------------------------------|
| | | | | | Metal Mounting Plate Catalog Number ① | DIN Rail Adapter Catalog Number ① | Metal Mounting Plate Catalog Number ① | DIN Rail Adapter Catalog Number ① |
| 25 | 115 | 150 | — | — | A30CNC25_ | A30CRC25_ | A30SNC25_ | A30SRC25_ |
| | 230 | 150 | 7-1/2 | 5-1/2 | | | | |
| | 460 | 125 | 10 | 7-1/2 | | | | |
| | 575 | 100 | 10 | 7-1/2 | | | | |
| 30 | 115 | 180 | — | — | A30CNE30_ | A30CRE30_ | A30SNE30_ | A30SRE30_ |
| | 230 | 180 | 10 | 7-1/2 | | | | |
| | 460 | 150 | 15 | 11 | | | | |
| | 575 | 120 | 15 | 11 | | | | |
| 40 | 115 | 240 | — | — | A30CNE40_ | A30CRE40_ | A30SNE40_ | A30SRE40_ |
| | 230 | 240 | 10 | 7-1/2 | | | | |
| | 460 | 200 | 20 | 15 | | | | |
| | 575 | 160 | 20 | 15 | | | | |
| 45 | 115 | 300 | — | — | A30CNE45_ | A30CRE45_ | A30SNE45_ | A30SRE45_ |
| | 230 | 300 | 15 | 11 | | | | |
| | 460 | 250 | 30 | 22 | | | | |
| | 575 | 200 | 30 | 22 | | | | |
| 60 | 115 | 360 | — | — | A30CNE60_ | — | A30SNE60_ | — |
| | 230 | 360 | 20 | 15 | | | | |
| | 460 | 300 | 40 | 30 | | | | |
| | 575 | 340 | 40 | 30 | | | | |
| 75 | 115 | 450 | — | — | A30CNE75_ | — | A30SNE75_ | — |
| | 230 | 450 | 20 | 18-1/2 | | | | |
| | 460 | 375 | 50 | 37 | | | | |
| | 575 | 300 | 50 | 37 | | | | |

Note

① Incomplete catalog number. Replace underscore (_) with suffix, see Page V5-T4-41.

When Ordering Specify

- Catalog number plus AC coil code, auxiliary contact code, OLR model designation and overload range code, see below

Single-Phase Starters—Open Type, B30 with C440 Electronic Overload

| Ampere Rating | | | | | Common Control | | Separate Control | |
|---------------------|--------------|--------------|--------------------|--------------------|---------------------------------------|-----------------------------------|---------------------------------------|-----------------------------------|
| Inductive Full Load | Line Voltage | Locked Rotor | Maximum Motor (hp) | Maximum Motor (kW) | Metal Mounting Plate Catalog Number ① | DIN Rail Adapter Catalog Number ① | Metal Mounting Plate Catalog Number ① | DIN Rail Adapter Catalog Number ① |
| 25 | 115 | 150 | 2 | 1.5 | B30CNC25_ | B30CRC25_ | B30SNC25_ | B30SRC25_ |
| | 230 | 150 | 3 | 2.2 | | | | |
| | 460 | 125 | — | — | | | | |
| | 575 | 100 | — | — | | | | |
| 30 | 115 | 180 | 2 | 1.5 | B30CNE30_ | B30CRE30_ | B30SNE30_ | B30SRE30_ |
| | 230 | 180 | 5 | 3.7 | | | | |
| | 460 | 150 | — | — | | | | |
| | 575 | 120 | — | — | | | | |
| 40 | 115 | 240 | 3 | 2.2 | B30CNE40_ | B30CRE40_ | B30SNE40_ | B30SRE40_ |
| | 230 | 240 | 7-1/2 | 5.5 | | | | |
| | 460 | 200 | — | — | | | | |
| | 575 | 160 | — | — | | | | |
| 45 | 115 | 300 | 3 | 2.2 | B30CNE45_ | B30CRE45_ | B30SNE45_ | B30SRE45_ |
| | 230 | 300 | 10 | 7.5 | | | | |
| | 460 | 250 | — | — | | | | |
| | 575 | 200 | — | — | | | | |

C440/X7 Electronic Overload Relay



C440 Electronic Overload Relay for Integrated Use with DP Contactors

C440 Overload Relay for Integrated Use with DP Contactors by Feature Set

| FLA Range (Amps) | DP Contactor Rating | Suffix Code | Overload Relay Catalog Number (Standard) | Overload Relay Catalog Number (Ground Fault) |
|------------------|---------------------|-------------|--|--|
| Frame D | | | | |
| 1-5 | 25-50A | 005 | C440A1A005SDD | C440A2A005SDD |
| 4-20 | 25-50A | 020 | C440A1A020SDD | C440A2A020SDD |
| 9-45 | 25-50A | 045 | C440A1A045SDD | C440A2A045SDD |
| Frame F | | | | |
| 20-100 | 60-75A | 100 | C440B1A100SDF | C440B2A100SDF |

Note



① Incomplete catalog number. Replace underscore (_) with suffix, see table above.

Accessories

CT Kits

4

Accessories

| | Description | Catalog Number |
|--|--|--------------------|
| Safety Cover  | Safety Cover Clear Lexan cover that mounts on top of the FLA dial and DIP switches when closed. | ZEB-XSC |
| Reset Bar  | Reset Bar Assembles to the top of the overload to provide a larger target area for door mounted reset operators. | ZEB-XRB |
| Remote Reset  | Remote Reset Remote reset module (24 Vdc) ^① | C440-XCOM |
| | Remote reset module (120 Vac) ^① | ZEB-XRR-120 |
| | Remote reset module (24 Vac) ^① | ZEB-XRR-24 |

Note

^① Customer can wire remote mounted button to reset module (that is, 22 mm pushbutton, catalog number M22-D-B-GB14-K10).

Technical Data and Specifications**Electronic Overload Relays up to 1500A**

| Description | Specification | |
|---|---|---|
| | 45 mm | 55 mm |
| Electrical Ratings | Range | Range |
| Operating voltage (three-phase) and frequency | 690 Vac (60/50 Hz) | 690 Vac (60/50 Hz) |
| FLA Range | | |
| | 0.33–1.65A 1–5A 4–20A 9–45A | 20–100A |
| Use with Contactors | | |
| XTIEC frames | B, C, D | F, G |
| Freedom NEMA sizes | 00, 0, 1, 2 | 3 |
| DP contactors | 25–50A | 60, 75A |
| Trip Class | | |
| | 10A, 10, 20, 30 Selectable | 10A, 10, 20, 30 Selectable |
| Motor Protection | | |
| Thermal overload setting | 1.05 x FLA: does not trip 1.15 x FLA: overload trip | 1.05 x FLA: does not trip 1.15 x FLA: overload trip |
| Feature | Range | Range |
| Phase loss | Fixed threshold 50% | Fixed threshold 50% |
| Phase unbalance (selectable: enable/disable) | Fixed threshold 50% | Fixed threshold 50% |
| Ground fault (selectable: enable/disable) | 50% of FLA dial setting >150% = 2 sec >250% = 1 sec | 50% of FLA dial setting >150% = 2 sec >250% = 1 sec |
| Reset | Manual/automatic | Manual/automatic |
| Indicators | | |
| Trip status | Orange flag | Orange flag |
| Mode LED | One flash: Overload operating properly Two flashes: Current is above FLA dial setting—pending trip | One flash: Overload operating properly Two flashes: Current is above FLA dial setting—pending trip |
| Options | | |
| Remote reset | Yes | Yes |
| Reset bar | Yes | Yes |
| Communication expansion module | Yes | Yes |
| Communication adapter | Yes | Yes |
| Capacity | | |
| Load terminals | | |
| Terminal capacity | 12–10 AWG (4–6 mm ²) 8–6 AWG (6–16 mm ²) | 6–1 AWG (16–50 mm ²) |
| Tightening torque | 20–25 lb-in (2.3–2.8 Nm) 25–30 lb-in (2.8–3.4 Nm) | 25–30 lb-in (2.8–3.4 Nm) |
| Input, auxiliary contact and remote reset terminals | | |
| Terminal capacity | 2 x (18–12) AWG | 2 x (18–12) AWG |
| Tightening torque | 5.3 lb-in (0.8–1.2 Nm) | 5.3 lb-in (0.8–1.2 Nm) |
| Voltages | | |
| Insulation voltage U _i (three-phase) | 690 Vac | 690 Vac |
| Insulation voltage U _i (control) | 500 Vac | 500 Vac |
| Rated impulse withstand voltage | 6000 Vac | 6000 Vac |
| Overvoltage category/pollution degree | III/3 | III/3 |

Electronic Overload Relays up to 1500A, continued

| Description | Specification | |
|--|---------------------------------------|---------------------------------------|
| | 45 mm | 55 mm |
| Auxiliary and Control Circuit Ratings | | |
| Conventional thermal continuous current | 5A | 5A |
| Rated operational current—IEC AC-15 | | |
| Make contact (1800 VA) | | |
| 120V | 15A | 15A |
| 240V | 15A | 15A |
| 415V | 0.5A | 0.5A |
| 500V | 0.5A | 0.5A |
| Break contact (180 VA) | | |
| 120V | 1.5A | 1.5A |
| 240V | 1.5A | 1.5A |
| 415V | 0.9A | 0.9A |
| 500V | 0.8A | 0.8A |
| IEC DC-13 (L/R F 15 ms1) | | |
| 0–250V | 1.0A | 1.0A |
| Rated operational current—UL B600 | | |
| Make contact (3600 VA) | | |
| 120V | 30A | 30A |
| 240V | 15A | 15A |
| 480V | 7.5A | 7.5A |
| 600V | 6A | 6A |
| Break contact (360 VA) | | |
| 120V | 3A | 3A |
| 240V | 1.5A | 1.5A |
| 480V | 0.75A | 0.75A |
| 600V | 0.6A | 0.6A |
| R300—Vdc ratings (28 VA) | | |
| 0–120V | 0.22A | 0.22A |
| 250V | 0.11A | 0.11A |
| Short-Circuit Rating without Welding | | |
| Maximum fuse | 6A gG/gL | 6A gG/gL |
| Environmental Ratings | | |
| Ambient temperature (operating) | –13° to 149°F (–25° to 65°C) | –13° to 149°F (–25° to 65°C) |
| Ambient temperature (storage) | –40° to 185°F (–40° to 85°C) | –40° to 185°F (–40° to 85°C) |
| Operating humidity UL 991 (H3) | 5% to 95% non-condensing | 5% to 95% non-condensing |
| Altitude (no derating) NEMA ICS1 | 2000m | 2000m |
| Shock (IEC 600068-2-27) | 15g any direction | 15g any direction |
| Vibration (IEC 60068-2-6) | 3g any direction | 3g any direction |
| Pollution degree per IEC 60947-4-1 | 3 for product (2 for pcb) | 3 for product (2 for pcb) |
| Ingress protection | IP20 | IP20 |
| Protection against direct contact when actuated from front (IEC 536) | Finger- and back-of-hand proof | Finger- and back-of-hand proof |
| Mounting position | Any | Any |
| Climatic proofing | Damp heat, constant to IEC 60068-2-30 | Damp heat, constant to IEC 60068-2-30 |

Electronic Overload Relays up to 1500A, continued

| Description | Specification 45 mm | 55 mm |
|---|--|--|
| Electrical/EMC | | |
| Radiated emissions IEC 60947-4-1-Table 15 EN 55011 (CISPR 11) Group 1, Class A, ISM | 30 MHz to 1000 MHz | 30 MHz to 1000 MHz |
| Conducted emissions IEC 60947-4-1-Table 14 EN 55011 (CISPR 11) Group 1; Class ISM | 0.15 MHz to 30 MHz | 0.15 MHz to 30 MHz |
| ESD immunity IEC 60947-4-1 (Table 13) | ±8 kV air, ±6 kV contact | ±8 kV air, ±6 kV contact |
| Radiated immunity IEC 60947-4-1 IEC 61000-4-3 | 10V/m 80 MHz–1000 MHz 3V/m from 1.4 to 2.7 GHz 80% amplitude modulated 1 kHz sine wave | 10V/m 80 MHz–1000 MHz 3V/m from 1.4 to 2.7 GHz 80% amplitude modulated 1 kHz sine wave |
| Conducted immunity IEC 60947-4-1, IEC 61000-4-6 | 140 dub (10V rms) 150 kHz–100 MHz | 140 dub (10V rms) 150 kHz–100 MHz |
| Fast transient immunity IEC 60947-4-1 (Table 13) IEC 61000-4-4 | ±4 kV using direct method with accessory installed in expansion bay ±2 kV using direct method | ±4 kV using direct method with accessory installed in expansion bay ±2 kV using direct method |
| Surge immunity IEC 60947-4-1 (Table 13) IEC 61000-4-5 a Class 4 | Three-phase power inputs: ±4 kV line-to-line (DM) ±4 kV line-to-ground (CM) With accessory installed in expansion bay: ±2 kV line-to-line (DM) →1.2/50 us; 2 kV line-to-earth, 1 kV line-to-line ±4 kV line-to-ground (CM) | Three-phase power inputs: ±4 kV line-to-line (DM) ±4 kV line-to-ground (CM) With accessory installed in expansion bay: ±2 kV line-to-line (DM) →1.2/50 us; 2 kV line-to-earth, 1 kV line-to-line ±4 kV line-to-ground (CM) |
| Power freq. magnetic field immunity IEC 60947-4-1, IEC 61000-4-8 | 30A/m, 50 Hz | 30A/m, 50 Hz |
| Electromagnetic field IEC 60947-4-1 Table 13, IEC 61000-4-3 | 10 V/m | 10 V/m |
| Distortion IEEE 519 | 5% THD max., 5th harmonic 3% max. | 5% THD max., 5th harmonic 3% max. |
| Electrostatic discharge (ESD) IEC 61000-4-2, EN 61131-2 | 4 kV contact 8 kV air discharge | 4 kV contact 8 kV air discharge |
| Electrical fast transient (EFT) IEC 61000-4-4, EN 61131-2 | ±2 kV using direct method | ±2 kV using direct method |
| Surge immunity IEC 61000-4-5, EN 61131-2 | ±2 kV line-to-ground (CM) | ±2 kV line-to-ground (CM) |

Wiring Diagrams

Single-Phase Connections

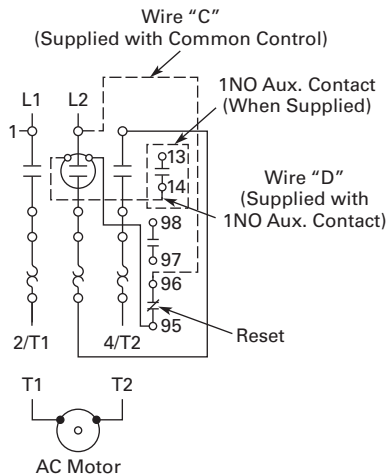

Three-Phase Connections

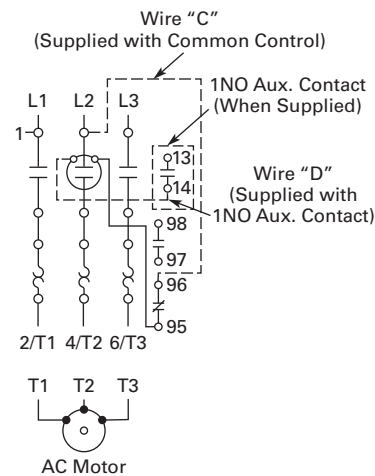

4.4

Definite Purpose Contactors and Starters

NEMA Type 1 Enclosed Control

15–60A Contactors—C25



4

15–60A Contactors—C25

Product Description

Eaton offers the Definite Purpose Contactors and Starters in NEMA 1 enclosures. The C25 contactors are available as enclosed. The A25 and B25 Definite Purpose Starters

combine the features and flexibility of the C25 Definite Purpose Contactors and Freedom Series Bimetallic Ambient Compensated Overload Relays mounted on a common mounting plate.

Contents

Description

Page

| | |
|---|-----------------|
| 15–60A Contactors—C25 | |
| Catalog Number Selection | V5-T4-47 |
| Product Selection | V5-T4-47 |
| Dimensions | V5-T4-48 |
| 25–60A Starters—A25, B25 | V5-T4-49 |
| 15–45A Starters—A27, B27 | V5-T4-52 |
| Accessories | V5-T4-55 |
| Options | V5-T4-57 |
| Technical Data and Specifications | V5-T4-58 |

Catalog Number Selection

15–60A Contactors—C25

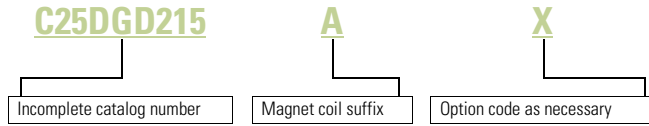

When Ordering Specify

- Catalog number plus magnet coil suffix, see **Page V5-T4-48**
- Modify catalog number for any options required, see Options, **Page V5-T4-57**

Product Selection

C25 Enclosed



Two-, Three- and Four-Pole NEMA Type 1 Enclosed Contactors

| Ampere Rating | Inductive Full Load | Resistive per Pole | Line Voltage | Locked Rotor | Maximum Motor (hp) | | Maximum Motor (kW) | | Number of Poles | NEMA Type 1 Catalog Number ① |
|---------------|---------------------|--------------------|--------------|--------------|--------------------|-------------|--------------------|-------------|-----------------|------------------------------|
| | | | | | Single-Phase | Three-Phase | Single-Phase | Three-Phase | | |
| 15 | 20 | | 115 | 90 | 3/4 | — | 0.40 | — | 2 | C25DGD215_ |
| | | | 230 | 90 | 2 | 3 | 1.5 | 2.2 | 3 | C25DGD315_ |
| | | | 460 | 75 | — | 5 | — | 3.7 | | C25DGD315_ |
| | | | 575 | 60 | — | 5 | — | 3.7 | | C25DGD315_ |
| 25 | 35 | | 115 | 150 | 2 | — | 1.5 | — | 2 | C25DGD225_ |
| | | | 230 | 150 | 3 | 7-1/2 | 2.2 | 5.5 | 3 | C25DGD325_ |
| | | | 460 | 125 | — | 10 | — | 7.5 | 4 | C25EGD425_ |
| | | | 575 | 100 | — | 10 | — | 7.5 | | C25EGD425_ |
| 30 | 40 | | 115 | 180 | 2 | — | 1.5 | — | 2 | C25DGD230_ |
| | | | 230 | 180 | 5 | 10 | 3.7 | 7.5 | 3 | C25DGD330_ |
| | | | 460 | 150 | — | 15 | — | 11 | 4 | C25EGD430_ |
| | | | 575 | 120 | — | 15 | — | 11 | | C25EGD430_ |
| 40 | 50 | | 115 | 240 | 3 | — | 2.2 | — | 2 | C25DGF240_ |
| | | | 230 | 240 | 7-1/2 | 10 | 5.5 | 7.5 | 3 | C25DGF340_ |
| | | | 460 | 200 | — | 20 | — | 15 | 4 | C25EGF440_ |
| | | | 575 | 160 | — | 20 | — | 15 | | C25EGF440_ |
| 50 | 65 | | 115 | 300 | 3 | — | 2.2 | — | 2 | C25DGJ250_ |
| | | | 230 | 300 | 10 | 15 | 7.5 | 11 | 3 | C25DGJ350_ |
| | | | 460 | 250 | — | 30 | — | 22 | | C25DGJ350_ |
| | | | 575 | 200 | — | 30 | — | 22 | | C25DGJ350_ |
| 60 | 75 | | 115 | 360 | 5 | — | 3.7 | — | 2 | C25FGF260_ |
| | | | 230 | 360 | 10 | 20 | 7.5 | 15 | 3 | C25FGF360_ |
| | | | 460 | 300 | — | 40 | — | 30 | | C25FGF360_ |
| | | | 575 | 240 | — | 40 | — | 30 | | C25FGF360_ |

Note

① Incomplete catalog number. Replace underscore (_) in catalog number with magnet coil suffix from table on **Page V5-T4-48**.

4.4

Definite Purpose Contactors and Starters

NEMA Type 1 Enclosed Control

4

Magnet Coil Suffix

| Voltage 60 Hertz | | | Voltage 60 Hertz | |
|---------------------|-------------|----------|---------------------|-----------|
| 50 Hertz | Coil Suffix | 60 Hertz | Coil Suffix | |
| AC ① | | | DC ④ | |
| 12 | 12 | R | 12 | 1R |
| 24 | 24 | T | 24 | 1T |
| 110–120 ② | 110–120 ② | A | 48 | 1W |
| 208–240 | 208–240 | E | 120 | 1A |
| 240 ③ | 220 | B | | |
| 277 | — | J | | |
| — | 380–415 | H | | |
| 440–480 | 440–480 | L | | |
| 550–600 | 550–600 | C | | |
| 12 | 12 | D | | |

Dimensions

Approximate Dimensions in Inches (mm)

C25 Contactors, NEMA 1 Enclosed

15–50 Ampere, Two- and Three-Pole (C799B18)

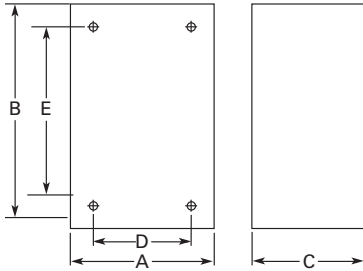

25–40 Ampere, Four-Pole— 60 Ampere, Two- and Three-Pole (C799B19)

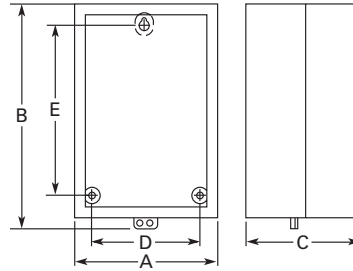

Dimensions and Shipping Weights

| Ampere Size | Number of Poles | Wide A | High B | Deep C | Mounting D | E | Shipping Weight Lbs (kg) |
|------------------------|-----------------|--------------|--------------|--------------|--------------|--------------|--------------------------|
| NEMA 1 Enclosed | | | | | | | |
| 15–50 | 2 and 3 | 4.10 (104.0) | 6.75 (171.0) | 3.50 (89.0) | 2.75 (70.0) | 4.88 (124.0) | 3.4 (1.5) |
| 25–40 | 4 | 5.62 (142.0) | 9.51 (241.0) | 4.81 (122.0) | 4.50 (114.0) | 8.00 (203.0) | 5.8 (2.6) |
| 60 | 2 and 3 | 5.62 (142.0) | 9.51 (241.0) | 4.81 (122.0) | 4.50 (114.0) | 8.00 (203.0) | 6.3 (2.9) |

Notes

- ① Class H AC coils available as option. Add **2** before AC coil suffix letter.
- ② 104–120A 50/60 Hz for 60A contactor.
- ③ Available through 50A.
- ④ Contactors with DC coils include an early break NC auxiliary contact, C320KGD1. See **Page V5-T4-62** for more detail.

25–60A Starters—A25, B25



Contents

| Description | Page |
|---|-----------------|
| 15–60A Contactors—C25 | V5-T4-46 |
| 25–60A Starters—A25, B25 | |
| Catalog Number Selection | V5-T4-50 |
| Product Selection | V5-T4-50 |
| Dimensions | V5-T4-51 |
| 15–45A Starters—A27, B27 | V5-T4-52 |
| Accessories | V5-T4-55 |
| Options | V5-T4-57 |
| Technical Data and Specifications | V5-T4-58 |

25–60A Starters—A25, B25

Product Description

A25 and B25 Definite Purpose Starters from Eaton's Electrical Sector combine the features and flexibility of the C25 Definite Purpose Contactors and Freedom Series Bi-metallic Ambient Compensated Overload Relays mounted on a common mounting plate.

Standards and Certifications

- UL Recognized Components UL File #E-1491, Guide NLDX2
- CSA Certified Components File #LR353, Guide 380W-1.14 Class 3211 04



4.4

Definite Purpose Contactors and Starters

NEMA Type 1 Enclosed Control

Catalog Number Selection

25–60A Starters—A25, B25

4

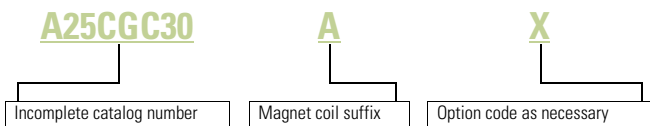

When Ordering Specify

- Catalog number plus magnet coil suffix, see **Page V5-T4-51**
- Modify catalog number for any options required, see Options, **Page V5-T4-57**
- Heater packs for specific FLA of motor, see **Page V5-T4-56**

Product Selection

A25, B25 Enclosed

Single- and Three-Phase NEMA Type 1 Enclosed Starters



| Ampere Rating | Inductive Full Load | Line Voltage | Locked Rotor | Maximum Motor (hp) | | Maximum Motor (kW) | | Single-Phase ^{①②} | | Three-Phase ^② | |
|---------------|---------------------|--------------|--------------|--------------------|-------------|--------------------|-------------|--|--|--|--|
| | | | | Single-Phase | Three-Phase | Single-Phase | Three-Phase | Common Control Catalog Number ^③ | Separate Control Catalog Number ^③ | Common Control Catalog Number ^③ | Separate Control Catalog Number ^③ |
| 25 | 115 | 150 | 2 | — | 1.5 | — | B25CGC25_ | B25SGC25_ | A25CGC25_ | A25SGC25_ | |
| | 230 | 150 | 3 | 7-1/2 | 2.2 | 5.5 | B25CGC25_ | B25SGC25_ | A25CGC25_ | A25SGC25_ | |
| | 460 | 125 | — | 10 | — | 7.5 | B25CGC25_ | B25SGC25_ | A25CGC25_ | A25SGC25_ | |
| | 575 | 100 | — | 10 | — | 7.5 | B25CGC25_ | B25SGC25_ | A25CGC25_ | A25SGC25_ | |
| 30 | 115 | 180 | 2 | — | 1.5 | — | B25CGC30_ | B25SGC30_ | A25CGC30_ | A25SGC30_ | |
| | 230 | 180 | 5 | 10 | 3.7 | 7.5 | B25CGC30_ | B25SGC30_ | A25CGC30_ | A25SGC30_ | |
| | 460 | 150 | — | 15 | — | 11 | B25CGC30_ | B25SGC30_ | A25CGC30_ | A25SGC30_ | |
| | 575 | 120 | — | 15 | — | 11 | B25CGC30_ | B25SGC30_ | A25CGC30_ | A25SGC30_ | |
| 40 | 115 | 240 | 3 | — | 2.2 | — | B25CGE40_ | B25SGE40_ | A25CGE40_ | A25SGE40_ | |
| | 230 | 240 | 7-1/2 | 10 | 5.5 | 7.5 | B25CGE40_ | B25SGE40_ | A25CGE40_ | A25SGE40_ | |
| | 460 | 200 | — | 20 | — | 15 | B25CGE40_ | B25SGE40_ | A25CGE40_ | A25SGE40_ | |
| | 575 | 160 | — | 20 | — | 15 | B25CGE40_ | B25SGE40_ | A25CGE40_ | A25SGE40_ | |
| 50 | 115 | 300 | — | — | — | — | — | — | A25CGE50_ | A25SGE50_ | |
| | 230 | 300 | — | 15 | — | 11 | — | — | A25CGE50_ | A25SGE50_ | |
| | 460 | 250 | — | 30 | — | 22 | — | — | A25CGE50_ | A25SGE50_ | |
| | 575 | 200 | — | 30 | — | 22 | — | — | A25CGE50_ | A25SGE50_ | |
| 60 | 115 | 360 | — | — | — | — | — | — | A25CGE60_ | A25SGE60_ | |
| | 230 | 360 | — | 20 | — | 15 | — | — | A25CGE60_ | A25SGE60_ | |
| | 460 | 300 | — | 40 | — | 30 | — | — | A25CGE60_ | A25SGE60_ | |
| | 575 | 240 | — | 40 | — | 30 | — | — | A25CGE60_ | A25SGE60_ | |

Notes

- ① Starters do not include heater packs. Select heater pack from tables, see **Page V5-T4-56**.
- ② Set of three heater packs required for single-phase applications.
- ③ Incomplete catalog number. Replace underscore (_) in catalog number with magnet coil suffix from table on **Page V5-T4-51**.

Magnet Coil Suffix

| Voltage 60 Hertz | | | Voltage 60 Hertz | |
|---------------------|-------------|----------|---------------------|-----------|
| 50 Hertz | Coil Suffix | 60 Hertz | Coil Suffix | |
| AC ① | | | DC ④ | |
| 12 | 12 | R | 12 | 1R |
| 24 | 24 | T | 24 | 1T |
| 110–120 ② | 110–120 ② | A | 48 | 1W |
| 208–240 | 208–240 | B | 120 | 1A |
| 240 ③ | 220 | J | | |
| 277 | — | H | | |
| — | 380–415 | L | | |
| 440–480 | 440–480 | C | | |
| 550–600 | 550–600 | D | | |

Dimensions

Approximate Dimensions in Inches (mm)

A25 and B25 Starters

25, 30, 40, 50 and 60 Ampere

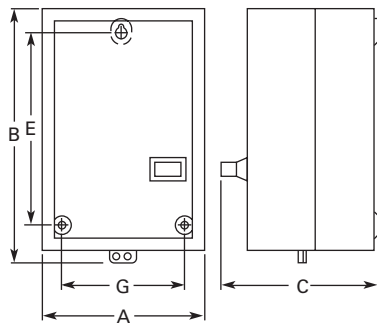

Dimensions and Shipping Weights

| Ampere Size | Wide A | High B | Deep C | Mounting E | Mounting G | Shipping Weight Lbs (kg) |
|---------------|--------------|---------------|--------------|---------------|---------------|--------------------------------|
| 25 and 30 | 5.63 (143.0) | 10.17 (258.0) | 5.81 (148.0) | 8.00 (203.0) | 4.50 (114.0) | 4.8 (2.2) |
| 40, 50 and 60 | 7.64 (194.0) | 13.27 (337.0) | 6.67 (169.0) | 10.75 (273.0) | 6.00 (152.0) | 10.6 (4.8) |

Notes

- ① Class H AC coils available as option. Add **2** before AC coil suffix letter.
- ② 104–120A 50/60 Hz for 60A starter.
- ③ Available through 50A.
- ④ Starters with DC coils include an early breaking auxiliary contact, C320KGD1. See **Page V5-T4-62** for more detail.

15–45A Starters—A27, B27



Contents

| <i>Description</i> | <i>Page</i> |
|---|-----------------|
| 15–60A Contactors—C25 | V5-T4-46 |
| 25–60A Starters—A25, B25 | V5-T4-49 |
| 15–45A Starters—A27, B27 | |
| Product Selection | V5-T4-53 |
| Dimensions | V5-T4-54 |
| Accessories | V5-T4-55 |
| Options | V5-T4-57 |
| Technical Data and Specifications | V5-T4-58 |

15–45A Starters—A27, B27

Product Description

A27 and B27 Definite Purpose Starters from Eaton’s Electrical Sector combine the features and flexibility of the C25 Definite Purpose Contactors and **XT** Series Bi-metallic Ambient Compensated Overload Relays.

Standards and Certifications

- UL Recognized Components UL File #E-1491, Guide NLDX2
- CSA Certified Components File #LR353, Guide 380W-1.14 Class 3211 04
- CE



Catalog Number Selection

15–45A Starters—A27, B27

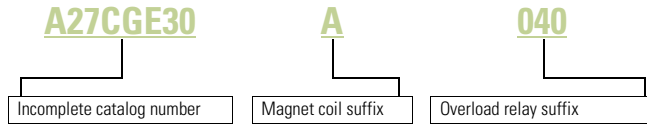

When Ordering Specify

- Catalog number plus magnet coil suffix plus overload relay suffix, see **Page V5-T4-54**

Product Selection

A27, B27 Enclosed Single- and Three-Phase NEMA Type 1 Enclosed Starters



| Ampere Rating | Inductive Full Load | Line Voltage | Locked Rotor | Maximum Motor (hp) | | Maximum Motor (kW) | | Single-Phase | | Three-Phase | |
|---------------|---------------------|--------------|--------------|--------------------|-------------|--------------------|-------------|---------------------------------|-----------------------------------|---------------------------------|-----------------------------------|
| | | | | Single-Phase | Three-Phase | Single-Phase | Three-Phase | Common Control Catalog Number ① | Separate Control Catalog Number ① | Common Control Catalog Number ① | Separate Control Catalog Number ① |
| 15 | 115 | 90 | 3/4 | — | 0.4 | — | B27CGC15_ | B27SGC15_ | A27CGC15_ | A27SGC15_ | |
| | 230 | 90 | 2 | 3 | 1.5 | 2.2 | B27CGC15_ | B27SGC15_ | A27CGC15_ | A27SGC15_ | |
| | 460 | 75 | — | 5 | — | 3.7 | B27CGC15_ | B27SGC15_ | A27CGC15_ | A27SGC15_ | |
| | 575 | 60 | — | 5 | — | 3.7 | B27CGC15_ | B27SGC15_ | A27CGC15_ | A27SGC15_ | |
| 25 | 115 | 150 | 2 | — | 1.5 | — | B27CGC25_ | B27SGC25_ | A27CGC25_ | A27SGC25_ | |
| | 230 | 150 | 3 | 7-1/2 | 2.2 | 5.5 | B27CGC25_ | B27SGC25_ | A27CGC25_ | A27SGC25_ | |
| | 460 | 125 | — | 10 | — | 7.5 | B27CGC25_ | B27SGC25_ | A27CGC25_ | A27SGC25_ | |
| | 575 | 100 | — | 10 | — | 7.5 | B27CGC25_ | B27SGC25_ | A27CGC25_ | A27SGC25_ | |
| 30 | 115 | 180 | 2 | — | 1.5 | — | B27CGE30_ | B27SGE30_ | A27CGE30_ | A27SGE30_ | |
| | 230 | 180 | 5 | 10 | 3.7 | 7.5 | B27CGE30_ | B27SGE30_ | A27CGE30_ | A27SGE30_ | |
| | 460 | 150 | — | 15 | — | 11 | B27CGE30_ | B27SGE30_ | A27CGE30_ | A27SGE30_ | |
| | 575 | 120 | — | 15 | — | 11 | B27CGE30_ | B27SGE30_ | A27CGE30_ | A27SGE30_ | |
| 40 | 115 | 240 | 3 | — | 2.2 | — | B27CGE40_ | B27SGE40_ | A27CGE40_ | A27SGE40_ | |
| | 230 | 240 | 7-1/2 | 10 | 5.5 | 7.5 | B27CGE40_ | B27SGE40_ | A27CGE40_ | A27SGE40_ | |
| | 460 | 200 | — | 20 | — | 15 | B27CGE40_ | B27SGE40_ | A27CGE40_ | A27SGE40_ | |
| | 575 | 160 | — | 20 | — | 15 | B27CGE40_ | B27SGE40_ | A27CGE40_ | A27SGE40_ | |
| 45 | 115 | 270 | 3 | — | 2.2 | — | B27CGE45_ | B27SGE45_ | A27CGE45_ | A27SGE45_ | |
| | 230 | 270 | 7-1/2 | 15 | 7.5 | 11 | B27CGE45_ | B27SGE45_ | A27CGE45_ | A27SGE45_ | |
| | 460 | 225 | — | 30 | — | 22 | B27CGE45_ | B27SGE45_ | A27CGE45_ | A27SGE45_ | |
| | 575 | 180 | — | 30 | — | 22 | B27CGE45_ | B27SGE45_ | A27CGE45_ | A27SGE45_ | |

Note

① Incomplete catalog number. Replace underscore (_) in catalog number with magnet coil suffix plus overload relay suffix from tables on **Page V5-T4-54**.

4.4

Definite Purpose Contactors and Starters

NEMA Type 1 Enclosed Control

4

Magnet Coil Suffix

| Voltage 60 Hertz | 50 Hertz | Coil Suffix | Voltage 60 Hertz | Coil Suffix |
|---------------------|----------|-------------|---------------------|-------------|
| AC ① | | | | |
| 12 | 12 | R | 12 | 1R |
| 24 | 24 | T | 24 | 1T |
| 110–120 | 110–120 | A | 48 | 1W |
| 208–240 | 208–240 | B | 120 | 1A |
| 240 ② | 220 | J | | |
| 277 | — | H | | |
| — | 380–415 | L | | |
| 440–480 | 440–480 | C | | |
| 550–600 | 550–600 | D | | |

Overload Relay Suffix

| Motor Full Load Amperes | Suffix Code | For use with Contactor Ampere Range |
|-------------------------|-------------|--|
| Frame C | | |
| 0.1–0.16 | P16 | 15–25A |
| 0.16–0.24 | P24 | 15–25A |
| 0.24–0.4 | P40 | 15–25A |
| 0.4–0.6 | P60 | 15–25A |
| 0.6–1 | 001 | 15–25A |
| 1–1.6 | 1P6 | 15–25A |
| 1.6–2.4 | 2P4 | 15–25A |
| 2.4–4 | 004 | 15–25A |
| 4–6 | 006 | 15–25A |
| 6–10 | 010 | 15–25A |
| 10–16 | 016 | 15–25A |
| 16–24 | 024 | 15–25A |
| 24–32 | 032 | 15–25A |
| Frame D | | |
| 6–10 | 010 | 30–45A |
| 10–16 | 016 | 30–45A |
| 16–24 | 024 | 30–45A |
| 24–40 | 040 | 30–45A |
| 40–57 | 057 | 30–45A |

Dimensions

Approximate Dimensions in Inches (mm)

A27 and B27 Starters

15, 25, 30, 40 and 50 Ampere

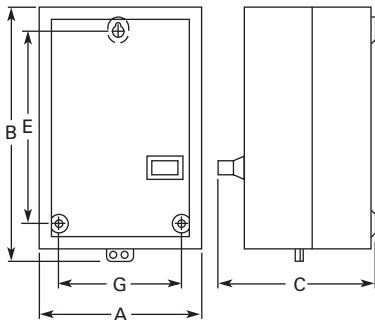

Dimensions and Shipping Weights

| Ampere Size | Wide A | High B | Deep C | Mounting E | Mounting G | Shipping Weight Lbs (kg) |
|---------------|--------------|---------------|--------------|---------------|---------------|--------------------------------|
| 25 and 30 | 5.63 (143.0) | 10.17 (258.0) | 5.81 (148.0) | 8.00 (203.0) | 4.50 (114.0) | 4.8 (2.2) |
| 40, 50 and 60 | 7.64 (194.0) | 13.27 (337.0) | 6.67 (169.0) | 10.75 (273.0) | 6.00 (152.0) | 10.6 (4.8) |

Notes

- ① Class H AC coils available as option. Add **2** before AC coil suffix letter.
- ② Available through 45A.
- ③ Starters with DC coils include an early breaking auxiliary contact, C320KGD1. See **Page V5-T4-62** for more detail.

Accessories

Auxiliary Contact Kits (Side Mounted)

Side Mounted Auxiliary Contact

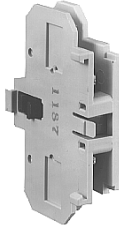

Heavy-Duty Pilot Rated for 10A at 600 Vac

| Circuit | With Standard Pressure Plate Terminals Catalog Number | With Pressure Plate and Quick Connect Terminals Catalog Number |
|-----------------------------|--|---|
| For 15 through 75A | | |
| 1NO | C320KG1 | C320KG11 |
| 1NC | C320KG2 | C320KG12 |
| 1NO-1NC | C320KG3 | C320KG13 |
| 2NO | C320KG4 | C320KG14 |
| 2NC | C320KG5 | C320KG15 |
| For 90A | | |
| 1NO | — | C320DPG10 |
| 1NC | — | C320DPG01 |
| 1NO-1NC | — | C320DPG11 |
| 2NO | — | C320DPG20 |
| For 120 through 360A | | |
| 1NO | C320KGS20 | — |
| 1NC | C320KGS21 | — |
| 1NO-1NC | C320KGS22 | — |

Side Mounted Snap Switch



Snap Switch Design Side Mounted Auxiliary Contacts

| Circuit | Snap Switch Design with Quick Connect Terminals Catalog Number |
|---------|---|
| 1NO-1NC | C320SNP11 |
| 2NO-2NC | C320SNP22 |

Magnet Coil Quick Connect Terminal

Description

Extra dual quick connect terminals (U-shaped) for magnet coil terminals ^②

Note

- ① To order, add suffix number **9** to the complete catalog number.
Example: C25DND215A**9**.

4.4

Definite Purpose Contactors and Starters

NEMA Type 1 Enclosed Control

Heater Packs

Fast Trip—Class 10 Heater Packs

Manual or Automatic Reset

Heater packs are shipped three to a carton.

Catalog numbers listed below are for three heater packs.

Fast Trip Ratings

| Motor Full Load Ampere Rating ^① | | | | Catalog Number ^② (Includes Three Heater Packs) |
|--|-------|-------|-------|--|
| Dial Position | | | | |
| A | B | C | D | |
| 0.26 | 0.313 | 0.367 | 0.42 | H2101B-3 |
| 0.384 | 0.464 | 0.543 | 0.623 | H2102B-3 |
| 0.57 | 0.688 | 0.806 | 0.924 | H2103B-3 |
| 0.846 | 1.02 | 1.2 | 1.37 | H2104B-3 |
| 1.28 | 1.55 | 1.83 | 2.1 | H2105B-3 |
| 1.92 | 2.33 | 2.74 | 3.15 | H2106B-3 |
| 2.3 | 2.79 | 3.28 | 3.77 | H2107B-3 |
| 3.38 | 4.1 | 4.82 | 5.54 | H2108B-3 |
| 4.96 | 6.03 | 7.09 | 8.16 | H2109B-3 |
| 7.07 | 8.58 | 10.1 | 11.6 | H2110B-3 |
| 9.6 | 11.2 | 12.8 | 14.4 | H2111B-3 |
| 14.4 | 17.5 | 20.7 | 23.8 | H2112B-3 |
| 18.7 | 21.8 | 25 | 28.1 | H2113B-3 |
| 23.5 | 27.3 | 31 | 34.8 | H2114B-3 |
| 28.3 | 32.6 | 37 | 41.3 | H2115B-3 |
| 36.6 | 42.3 | 48.1 | 53.8 | H2116B-3 |
| 53.8 | 60.8 | 67.9 | 74.9 | H2117B-3 |

Trip Curves, see Page V5-T4-58.

Notes

- ① For motor full load amperes between listed values, adjust dial clockwise for higher or counter-clockwise for lower motor currents. The currents listed are for 1.5 service factor motors. A position adjustment is provided for 1.0 service factor motors.
- ② Set of three heater packs are required for both single- and three-phase applications.

Standard Trip—Class 20 Heater Packs

Manual or Automatic Reset

Heater packs are shipped three to a carton.

Catalog numbers listed below are for three heater packs.

Standard Trip Ratings

| Motor Full Load Ampere Rating ^① | | | | Catalog Number ^② (Includes Three Heater Packs) |
|--|-------|-------|-------|--|
| Dial Position | | | | |
| A | B | C | D | |
| 0.254 | 0.306 | 0.359 | 0.411 | H2001B-3 |
| 0.375 | 0.452 | 0.53 | 0.607 | H2002B-3 |
| 0.56 | 0.676 | 0.791 | 0.907 | H2003B-3 |
| 0.814 | 0.983 | 1.15 | 1.32 | H2004B-3 |
| 1.2 | 1.45 | 1.71 | 1.96 | H2005B-3 |
| 1.79 | 2.16 | 2.53 | 2.9 | H2006B-3 |
| 2.15 | 2.6 | 3.04 | 3.49 | H2007B-3 |
| 3.23 | 3.9 | 4.56 | 5.23 | H2008B-3 |
| 4.55 | 5.5 | 6.45 | 7.4 | H2009B-3 |
| 6.75 | 8.17 | 9.58 | 11 | H2010B-3 |
| 9.14 | 10.8 | 12.4 | 14 | H2011B-3 |
| 14 | 16.9 | 19.9 | 22.8 | H2012B-3 |
| 18.7 | 22.7 | 26.7 | 30.7 | H2013B-3 |
| 23.5 | 28.5 | 33.5 | 38.5 | H2014B-3 |
| 29 | 34 | 39.1 | 44.1 | H2015B-3 |
| 39.6 | 45.5 | 51.5 | 57.4 | H2016B-3 |
| 53.9 | 60.9 | 67.9 | 74.9 | H2017B-3 |

Trip Curves, see Page V5-T4-58.

Options

To order C25, C65, A25 and B25 contactors and starters with the factory installed options listed below, change the basic catalog number listed in the product selection table as noted.

Factory Installed Options

| Description | Code Letter | Number of Poles |
|---|-------------|-----------------------------|
| Terminals— 15A through 50A | | |
| Binding head screws | | |
| Without quick connect terminals | A | 2-, 3-, 4-pole |
| With quick connect terminals (side-by-side) | B | 2-, 3-, 4-pole |
| With quick connect terminals (vertical in-line) | G | 2-, 3-pole |
| Screw/pressure plate ^① | | |
| Without quick connect terminals | C | 2-, 3-, 4-pole |
| With quick connect terminals (side-by-side) | D | 2-, 3-, 4-pole |
| With quick connect terminals (vertical in-line) | H | 2-, 3-pole |
| Box lugs (#2 posidrive/slotted screw) | | |
| Without quick connect terminals | E | 2-, 3-, 4-pole ^② |
| With quick connect terminals (side-by-side) | F | 2-, 3-, 4-pole ^② |
| With quick connect terminals (vertical in-line) | J | 2-, 3-pole |
| Box lugs (hex socket allen head screw) | | |
| Without quick connect terminals | K | 2-, 3-pole |
| With quick connect terminals (side-by-side) | L | 2-, 3-pole |
| With quick connect terminals (vertical in-line) | M | 2-, 3-pole |
| Terminals— 60A through 75A ^③ | | |
| Box lugs (slotted screw) | | |
| Without quick connect terminals | E | 2-, 3-pole |
| With quick connect terminals | F | 2-, 3-pole |

Notes

- ① Screw/pressure plate terminals are not available on 50A contactors.
- ② Four-pole contactors have box lugs with slotted screws.
- ③ Replace letter in the 6th position of catalog number with code letter listed. Example: Change C25FNF250 to C25FNE250.

Technical Data and Specifications

20–40A, Compact Single- and Two-Pole—C25

| Description | Specification |
|--|---|
| Insulation voltage | 690V |
| Current rated and hp/kw rated contacts | Double break |
| Magnet coil | Class F, 155°C |
| Contact arc covers | Standard on all contactors |
| Standard power terminals | 5/16 in hex washer head screws Quad (4) quick connect terminals on all line and load terminals Box lugs available as option |
| Line and load terminal designations | Marked on contactors |
| Operating temperature range | –13° to 158°F (–25° to 70°C) |
| Terminal wire range | |
| Hex washer head screws | 6–10 AWG, 30 lb-in torque rating |
| Box lugs | 6–10 AWG, 35 lb-in torque rating 8 AWG, 40 lb-in torque rating 6–4 AWG, 45 lb-in torque rating |
| Mounting position | Vertical, horizontal or tabletop |

Coil Characteristics

| AC Coil Voltage 50/60 Hz | Maximum Inrush VA | Maximum Sealed | |
|-----------------------------|----------------------|----------------|-------|
| | | VA | Watts |
| Single-Pole | | | |
| 24 | 33 | 6 | 2 |
| 120 | 33 | 6 | 2 |
| 208/240 | 33 | 6 | 2 |
| 277 | 33 | 6 | 2 |

| AC Coil Voltage 50/60 Hz | Maximum Inrush VA | Maximum Sealed | |
|-----------------------------|----------------------|----------------|-------|
| | | VA | Watts |
| Two-Pole | | | |
| 24 | 41 | 6.5 | 3 |
| 120 | 41 | 6.5 | 3 |
| 208/240 | 41 | 6.5 | 3 |
| 277 | 41 | 6.5 | 3 |

Trip Curves

Bimetallic Ambient Compensated Overload Relay—25°C Open Rating

Class 10 Overload Relay (25°C Open Rating)

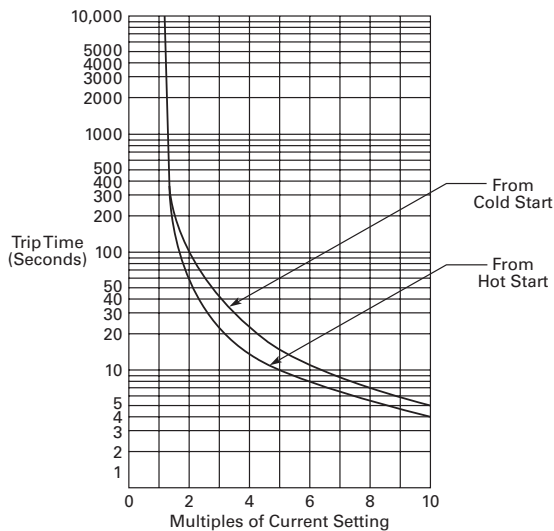

Class 20 Overload Relay (25°C Open Rating)

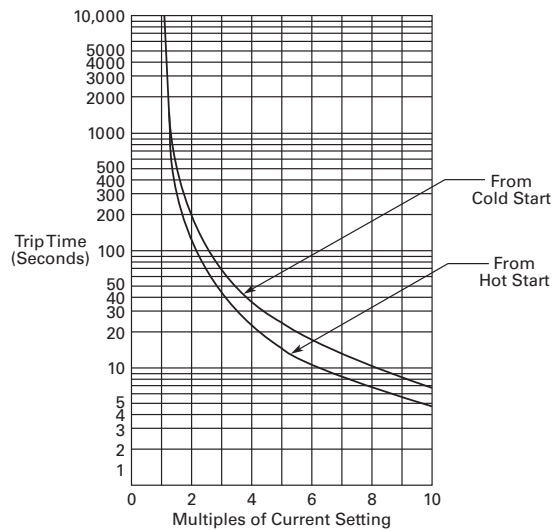

Renewal Parts

Renewal Contact Kits for C25 Definite Purpose Contactors

- Replace complete contactor for:
 - C25A_
 - C25B_
 - C25C_
 - C25D_

Renewal Contact Kits for C25 Definite Purpose Contactors

| Catalog Number | Single-Pole Kit Part Number | Two-Pole Kit Part Number | Three-Pole Kit Part Number |
|----------------|-----------------------------|--------------------------|----------------------------|
| C25FNF250 | — | 6-65-5 | — |
| C25FNF350 | — | — | 6-65-6 |
| C25FNF260 | — | 6-65-7 | — |
| C25FNF360 | — | — | 6-65-8 |
| C25FNF275 | — | 6-65-20 | — |
| C25FNF375 | — | — | 6-65-19 |
| C25GNF290 | — | — | — |
| C25GNF390 | — | — | — |
| C25HNE3120 | — | — | 6-43-6 |
| C25KNE3200 | — | — | 6-288 |
| C25KNE3300 | — | — | 6-286 |
| C25LNE3360 | — | — | 6-45-2 |

Product Selection

AC Coils

| AC Coil Voltage | Frequency | Inrush (Maximum) | | Sealed (Maximum) | | Coil Suffix | Class | Part Number |
|--|-----------|------------------|-------|------------------|-------|-------------|----------------|------------------|
| | | VA | Watts | VA | Watts | | | |
| 15, 25, 30 and 40A – Two- and Three-Pole (Series D1 and E1) | | | | | | | | |
| 12 | 60 | 74.85 | 46.1 | 5.53 | 1.68 | R | Class F, 155°C | 9-3185-5 |
| 24 | | 81.35 | 49.7 | 5.83 | 1.74 | T | | 9-3185-6 |
| 110/120 | | 74.69 | 51.6 | 5.79 | 1.81 | A | | 9-3185-1 |
| 208/240 | | 82.64 | 59.1 | 6.96 | 2.38 | B | | 9-3185-2 |
| 220/240 | 60 | 74.03 | 51.8 | 5.85 | 1.99 | J | Class F, 155°C | 9-3185-10 |
| 440/480 | | 73.39 | 52.1 | 6.09 | 2.58 | C | | 9-3185-3 |
| 550/600 | | 79.47 | 51.7 | 6.56 | 3.05 | D | | 9-3185-4 |
| 277 | | 72.88 | 52.4 | 6.09 | 2.58 | H | | 9-3185-7 |
| 380/415 | 50 | 64.5 | 50.6 | 6.08 | 2.43 | L | Class F, 155°C | 9-3185-8 |
| 15, 25, 30 and 40A – Two- and Three-Pole (Series C1) | | | | | | | | |
| 12 | 60 | 65 | 30 | 11 | 2.5 | R | Class F, 155°C | 9-3125-5 |
| 24 | | 65 | 30 | 11 | 2.5 | T | | 9-3125-6 |
| 104/120 | | 65 | 30 | 11 | 2.5 | A | | 9-3125-1 |
| 208/240 | 50 | 75 | 35 | 17 | 3.5 | B | Class F, 155°C | 9-3125-2 |
| 440/480 | | 75 | 35 | 17 | 3.5 | C | | 9-3125-3 |
| 550/600 | | 75 | 35 | 17 | 3.5 | D | | 9-3125-4 |
| 277 | 60 | 65 | 30 | 11 | 2.5 | H | Class F, 155°C | 9-3125-8 |
| 380/415 | 50 | 75 | 35 | 17 | 3.5 | L | Class F, 155°C | 9-3125-8 |

AC Coils, continued

| AC Coil Voltage | Frequency | Inrush (Maximum) | | Sealed (Maximum) | | Coil Suffix | Class | Part Number |
|---|-----------|------------------|-------|------------------|-------|-------------|----------------|------------------|
| | | VA | Watts | VA | Watts | | | |
| 15, 25, 30 and 40A – Two- and Three-Pole (Series D1 and E1) | | | | | | | | |
| 12 | 60 | 74.85 | 46.1 | 5.53 | 1.68 | R | Class H, 180°C | 9-3252-5 |
| 24 | | 81.35 | 49.7 | 5.83 | 1.74 | T | | 9-3252-6 |
| 110/120 | | 74.69 | 51.6 | 5.79 | 1.81 | A | | 9-3252-1 |
| 208/240 | | 82.64 | 59.1 | 6.96 | 2.38 | B | | 9-3252-2 |
| 220/240 | 60 | 74.03 | 51.8 | 5.85 | 1.99 | J | Class H, 180°C | 9-3252-10 |
| 440/480 | | 73.39 | 52.1 | 6.09 | 2.58 | C | | 9-3252-3 |
| 550/600 | | 79.47 | 51.7 | 6.56 | 3.05 | D | | 9-3252-4 |
| 277 | | 72.88 | 52.4 | 6.09 | 2.58 | H | | 9-3252-7 |
| 380/415 | 50 | 64.5 | 50.6 | 6.08 | 2.43 | L | | Class H, 180°C |
| 50A – Two- and Three-Pole (Series D1 and E1) | | | | | | | | |
| 12 | 60 | 115.8 | 73.6 | 7.71 | 2.8 | R | Class F, 155°C | 9-3186-5 |
| 24 | | 118.1 | 70.7 | 7.58 | 2.79 | T | | 9-3186-6 |
| 110/120 | | 110.7 | 73.3 | 7.67 | 2.89 | A | | 9-3186-1 |
| 208/240 | | 124.9 | 90.3 | 10.04 | 3.74 | B | | 9-3186-2 |
| 220/240 | 60 | 112.9 | 76.2 | 7.6 | 3.02 | J | Class F, 155°C | 9-3186-10 |
| 440/480 | | 114.7 | 75.6 | 8.01 | 3.68 | C | | 9-3186-3 |
| 550/600 | | 109 | 78.6 | 8.21 | 4.11 | D | | 9-3186-4 |
| 277 | | 115.4 | 73.1 | 7.73 | 3.12 | H | | 9-3186-7 |
| 380/415 | 50 | 110.3 | 77 | 8.66 | 3.31 | L | | Class F, 155°C |
| 50A – Two- and Three-Pole (Series D1 and E1) | | | | | | | | |
| 12 | 60 | 115.8 | 73.6 | 7.71 | 2.8 | R | Class H, 180°C | 9-3253-5 |
| 24 | | 118.1 | 70.7 | 7.58 | 2.79 | T | | 9-3253-6 |
| 110/120 | | 110.7 | 73.3 | 7.67 | 2.89 | A | | 9-3253-1 |
| 208/240 | | 124.9 | 90.3 | 10.04 | 3.74 | B | | 9-3253-2 |
| 220/240 | 60 | 112.9 | 76.2 | 7.6 | 3.02 | J | Class H, 180°C | 9-3253-10 |
| 440/480 | | 114.7 | 75.6 | 8.01 | 3.68 | C | | 9-3253-3 |
| 550/600 | | 109 | 78.6 | 8.21 | 4.11 | D | | 9-3253-4 |
| 277 | | 115.4 | 73.1 | 7.73 | 3.12 | H | | 9-3253-7 |
| 380/415 | 50 | 110.3 | 77 | 8.66 | 3.31 | L | | Class H, 180°C |
| 60 and 75A – Two- and Three-Pole; 25, 30 and 40A – Four-Pole | | | | | | | | |
| 12 | 60 | 204 | 84 | 36.5 | 8 | R | Class B, 130°C | 9-3256-5 |
| 24 | | | | | | T | | 9-3256-6 |
| 104/120 | | | | | | A | | 9-3256-1 |
| 208/240 | 50 | 240 | 100.8 | 50.4 | 10.8 | B | Class B, 130°C | 9-3256-2 |
| 440/480 | | | | | | C | | 9-3256-3 |
| 550/600 | | | | | | D | | 9-3256-4 |
| 277 | 60 | 204 | 84 | 36.5 | 8 | H | Class B, 130°C | 9-3256-7 |
| 380/415 | 50 | 199 | 88.8 | 37.8 | 8.8 | L | Class B, 130°C | 9-3256-8 |

AC Coils, continued

| AC Coil Voltage | Frequency | Inrush (Maximum) | | Sealed (Maximum) | | Coil Suffix | Class | Part Number |
|--|-----------|------------------|-------|------------------|-------|-------------|----------------|------------------|
| | | VA | Watts | VA | Watts | | | |
| 90A – Two- and Three-Pole (Series F1) | | | | | | | | |
| 24 | 50/60 | 325/300 | — | 48/35 | 12 | T | Class B, 130°C | 9-3080-1 |
| 110/120 | | | | | | A | | 9-3080-2 |
| 208–220 | | | | | | B | | 9-3080-3 |
| 380–415 | 50/60 | 325/300 | — | 48/35 | 12 | C | Class B, 130°C | 9-3080-5 |
| 277 | 60 | 325/300 | — | 48/35 | 12 | H | Class B, 130°C | 9-3080-4 |
| 120A – Three-Pole | | | | | | | | |
| 24 | 50/60 | 390 | 112 | 49.8 | 13 | T | Class B, 130°C | 9-2756-16 |
| 110/120 | | | | | | A | | 9-2756-1 |
| 220/240 | | | | | | B | | 9-2756-2 |
| 440/480 | | | | | | C | | 9-2756-3 |
| 550/600 | | | | | | D | | 9-2756-4 |
| 208 | 60 | 390 | 112 | 49.8 | 13 | E | Class B, 130°C | 9-2756-5 |
| 277 | | | | | | H | | 9-2756-9 |
| 200, 300 and 360A – Three-Pole | | | | | | | | |
| 110/120 | 50/60 | 1040 | 216 | 116 | 17 | A | Class F, 155°C | 9-1891-1 |
| 220/240 | | | | | | B | | 9-1891-2 |
| 440/480 | | | | | | C | | 9-1891-3 |
| 550/600 | | | | | | D | | 9-1891-4 |
| 208 | 60 | 1040 | 216 | 116 | 17 | E | Class F, 155°C | 9-1891-13 |
| 277 | | | | | | H | | 9-1891-26 |

DC Operation

These DC coils have separate pick-up and seal windings. The pick-up winding must be connected to an early break normally closed auxiliary contact block and provide the magnetic force required to close the magnet. As the magnet approaches the closed position, the early break normally closed contact is opened and the holding coil is inserted in series with the pick-up winding.

The early break contact block (C320KGD1) has to be attached to the side of the contactor, taking up one of the positions available for add-on auxiliary contact blocks.

DC Coil Elementary Diagram—Contactors and Starters

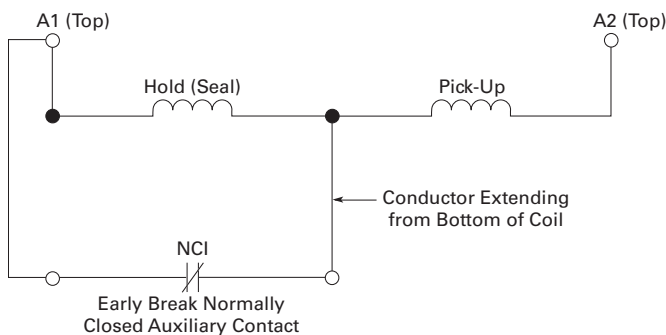

DC Coils ①

| DC Coil Voltage | Inrush (Maximum) | | Sealed (Maximum) | | Coil Suffix | Class | Part Number |
|---|------------------|-------|------------------|-------|-------------|----------------|-------------|
| | Amperes | Watts | Amperes | Watts | | | |
| 15, 25, 30 and 40A—Two- and Three-Pole (Series D1 and E1) | | | | | | | |
| 12 | 5.8 | 69 | 0.272 | 3.27 | 1R | Class F, 155°C | 9-3254-2 |
| 24 | 2.9 | 69 | 0.13 | 3.12 | 1T | | 9-3254-3 |
| 48 | 1.5 | 72 | 0.07 | 3.37 | 1W | | 9-3254-4 |
| 120 | 0.61 | 73 | 0.03 | 3.68 | 1A | | 9-3254-5 |
| 50A—Two- and Three-Pole (Series D1 and E1) | | | | | | | |
| 12 | 5.8 | 69 | 0.272 | 3.27 | 1R | Class F, 155°C | 9-3255-2 |
| 24 | 2.9 | 69 | 0.13 | 3.12 | 1T | | 9-3255-3 |
| 48 | 1.5 | 72 | 0.07 | 3.37 | 1W | | 9-3255-4 |
| 120 | 0.61 | 73 | 0.03 | 3.68 | 1A | | 9-3255-5 |
| 15, 25, 30 and 40A—Two- and Three-Pole (Series C1) | | | | | | | |
| 12 | 4.7 | 51 | 232 mA | 1.8 | 1R | Class F, 155°C | 9-3126-1 |
| 24 | 2.7 | 64 | 110 mA | 2.4 | 1T | | 9-3126-2 |
| 48 | 1.4 | 65 | 55 mA | 2.5 | 1W | | 9-3126-3 |
| 60 and 75A—Two- and Three-Pole; 25, 30 and 40A—Four-Pole (Series C1) | | | | | | | |
| 12 | 15.4 | 126 | 0.434 | 5.26 | 1R | Class F, 155°C | 9-3257-1 |
| 24 | 6.2 | 88.4 | 0.211 | 5.12 | 1T | | 9-3257-2 |
| 48 | 2.9 | 76.2 | 0.102 | 4.92 | 1W | | 9-3257-3 |
| 120 | 1.1 | 67.3 | 0.044 | 5.32 | 1A | | 9-3257-4 |

Note

① DC coils require an early break NC auxiliary contact C320KGD1 (1NCI) or C320KGD2 (1NO-1NCI). Order separately, not included with replacement coil.

Heavy-Duty Special Purpose Contactors



Contents

| Description | Page |
|---|-----------------|
| Heavy-Duty Special Purpose Contactors | |
| Product Selection | V5-T4-64 |
| Accessories | V5-T4-64 |
| Renewal Parts | V5-T4-65 |
| Technical Data and Specifications | V5-T4-65 |
| Dimensions | V5-T4-66 |

Product Description

The DPCK Contactors are designed to provide peak performance and reliability on special switching applications. These heavy-duty special purpose contactors are rated for applications up to 1500 Vac.

Application Description

- Typical applications include mining equipment, welding equipment, heating and air conditioning applications and other loads that require a compact heavy-duty contactor rated up to 1500 Vac
- The DPCK Contactors are supplied with bolts and washers on each terminal for use with customer supplied lugs

Features

- A double wound epoxy coil allows for lower temperature rise and longer life
- The U-shaped magnet provides fast, reliable action, long life and lower power requirements
- Stainless steel kick-out springs
- Rugged single-piece mounting plate
- Allows up to four double circuit auxiliary contacts per contactor

Benefits

- All contacts are silver alloy, providing long life and resistance to welding
- Straight-through wiring and up front terminals allow for fast, easy installation
- Loosening two captive screws allows for easy visual inspection of contacts

4.6

Definite Purpose Contactors and Starters

Heavy-Duty Special Purpose Contactors

Product Selection

When Ordering Specify

- Catalog number with any required accessories from below

4

35A 600/1000V
Contactor



DPCK Air Break Contactors—Two- and Three-Pole ^①

| Open Ampere Rating | | | Coil Voltage 60 Hz ^② | Open Type— Two-Pole Catalog Number | Three-Pole Catalog Number |
|--------------------|-------|-------|------------------------------------|--|------------------------------|
| 600V | 1000V | 1500V | | | |
| 35 | 35 | 20 | 240 | DPCK2035WW | DPCK3035WW |
| | | | 480 | DPCK2035XW | DPCK3035XW |
| | | | 600 | DPCK2035EW | DPCK3035EW |
| 100 | 100 | 75 | 240 | DPCK2100WW | DPCK3100WW |
| | | | 480 | DPCK2100XW | DPCK3100XW |
| | | | 600 | DPCK2100EW | DPCK3100EW |

250A 600V Contactor



DPCK Air Break Contactors—Four- and Five-Pole ^①

| Open Ampere Rating | | | Coil Voltage 60 Hz ^② | Open Type— Four-Pole Catalog Number | Five-Pole Catalog Number |
|--------------------|-------|-------|------------------------------------|---|-----------------------------|
| 600V | 1000V | 1500V | | | |
| 35 | 35 | 20 | 240 | DPCK4035WW | DPCK5035WW |
| | | | 480 | DPCK4035XW | DPCK5035XW |
| | | | 600 | DPCK4035EW | DPCK5035EW |

Accessories

Accessory Kits

| Description | Catalog Number |
|--|----------------|
| Auxiliary contacts, 1NO-1NC | J11 |
| Horizontal Mechanical Interlock | |
| 35A | 180C113G09 |
| 100A | 1264C37G01 |
| Surge suppressor | SS56 |

Notes

- ^① Holding circuit auxiliary contact not included. If required, order from Accessories above.
- ^② For other coil voltages, refer to replacement coils on **Page V5-T4-65** and insert proper letter in place of **9th** character of listed catalog number. Example: DPCK3035WW with 380/50 coil DPCK3035HW.

Renewal Parts

DPCK Contactor Renewal Parts

| Description | Hz | Coil Suffix Code | 35A | Four-, Five-Pole | 100A |
|--------------------|-------|------------------|------------------------------|-------------------|------------------------------|
| | | | Two-, Three-Pole Part Number | Part Number | Two-, Three-Pole Part Number |
| Contact Kit | | | | | |
| Two-pole | — | — | 180C180G01 | ① | 180C180G05 |
| Three-pole | — | — | 180C180G02 | ② | 180C180G06 |
| ARC box | — | — | 673B439G01 | 673B439G02 | 673B440G01 |
| Upper base | — | — | 673B439G03 | 673B439G04 | 673B440G02 |
| Lower base | — | — | 673B439G05 | 673B439G06 | 673B440G03 |
| Crossbar | — | — | 673B439G07 | 673B439G08 | 673B440G04 |
| Magnet Coil | | | | | |
| 120/110 | 60/50 | A | 1266C28G01 | 1266C29G01 | 1254C70G01 |
| 110 | 60 | V | 1266C28G08 | 1266C29G06 | 1254C70G08 |
| 208/220 | 60 | B | 1266C28G02 | 1266C29G02 | 1254C70G02 |
| 220/240 | 60 | — | N/A | N/A | N/A |
| 240/220 | 60/50 | W | 1266C28G09 | 1266C29G07 | 1254C70G03 |
| 480/440 | 60/50 | X | 1266C28G10 | 1266C29G08 | 1254C70G05 |
| 440/480 | 60 | — | N/A | N/A | N/A |
| 600/550 | 60/50 | E | 1266C28G05 | 1266C29G04 | 1254C70G07 |
| 550 | 60 | — | N/A | N/A | N/A |
| 380 | 50 | H | 1266C28G06 | 1266C29G09 | N/A |
| 380/110 | 60 | — | N/A | N/A | 1254C70G12 |

Technical Data and Specifications

Magnet Coil VA—60 Hz

| Catalog Number | Open VA | Closed VA | Closed Watts |
|-----------------|---------|-----------|--------------|
| DPCK3035 | 625 | 50 | 18 |
| DPCK3100 | 1200 | 130 | 40 |

Notes

- ① For a four-pole device, use (2) of the 180C180G01 contact kits.
- ② For a five-pole device, use (1) of the 180C180G01 and (1) of the 180C180G02 contact kits.

4.6

Definite Purpose Contactors and Starters

Heavy-Duty Special Purpose Contactors

4

Contact Ratings

| Volts | Full Load Current (Amperes) | Locked Rotor Current (Amperes) | Resistive Load (Amperes) | Lighting Load (Amperes) |
|--------------------------------|-----------------------------|--------------------------------|--------------------------|-------------------------|
| Catalog Number DPCK3035 | | | | |
| 120 | 35 | 240 | 35 | 35 |
| 240 | 35 | 240 | 35 | 35 |
| 480 | 35 | 200 | 35 | 35 |
| 600 | 35 | 200 | 35 | 35 |
| 1000 | 35 | 200 | — | — |
| 1500 | 20 | 160 | — | — |
| Catalog Number DPCK3100 | | | | |
| 120 | 100 | 600 | 100 | 100 |
| 240 | 100 | 600 | 100 | 100 |
| 480 | 100 | 600 | 100 | 100 |
| 600 | 100 | 600 | 100 | 100 |
| 1000 | 100 | 450 | — | — |
| 1500 | 75 | 300 | — | — |

Dimensions

Approximate Dimensions in Inches (mm)

DPCK Air Break Contactors—35 and 100 Ampere

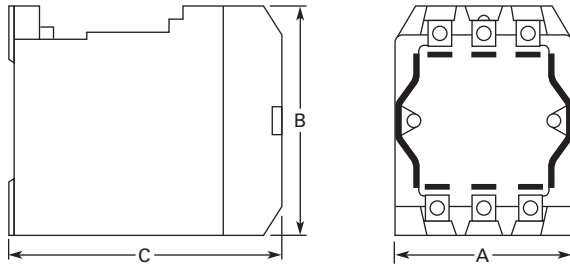

| Poles | Wide A | High B | Deep C | Shipping Weight Lbs (kg) |
|------------------------|--------------|--------------|--------------|--------------------------|
| 35A Contactors | | | | |
| 2 and 3 | 4.06 (103.1) | 5.44 (138.2) | 5.63 (143.0) | 16.0 (7.3) |
| 4 and 5 | 6.06 (153.9) | 5.44 (138.2) | 5.63 (143.0) | 19.0 (8.6) |
| 100A Contactors | | | | |
| 2 and 3 | 5.38 (136.7) | 7.81 (198.4) | 6.75 (171.5) | 28.0 (12.7) |

Mill Type Contactors

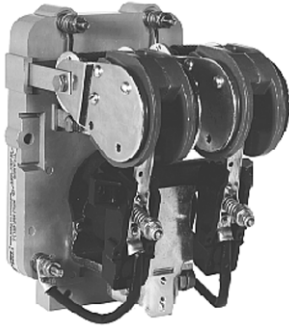

Contents

| Description | Page |
|---|-----------------|
| Mill Type Contactors | |
| Catalog Number Selection | V5-T4-68 |
| Product Selection | V5-T4-68 |
| Accessories | V5-T4-69 |
| Options | V5-T4-69 |
| Technical Data and Specifications | V5-T4-69 |
| 600V Contactors | V5-T4-70 |
| DPM 750V Contactor | V5-T4-74 |
| AVD-Contactor | V5-T4-77 |
| D-Contactor | V5-T4-80 |
| Reversing/Assignment Contactor | V5-T4-83 |

Mill Type Contactors

Product Description

These DC mill type contactors are designed for heavy industry service and are suitable for use on moving machinery. The contactors listed here are for surface mounting on steel panels and front-of-panel wiring. The power stud assembly is mounted on the side of the contactor, rather than as part of a separate mounting kit.

Application Description

- Applications include mining, milling, cranes and transportation
- These contactors utilize DC coils

Note: Be sure to utilize a rectifier module if the only control voltage source available is 120 Vac.

Features

- Forged steel armature levers and magnet frames for superior physical strength
- Self-lubricating bearings
- Long contact life

Standards and Certifications

- CMAA 5.6.6-2
- NEMA ICS3-441, 442, 443
- NEMA ICS2-331.23
- NEMA ICS2-110.05.02
- NEMA ICS2-125.21.02

Catalog Number Selection

DC Mill Type Contactor

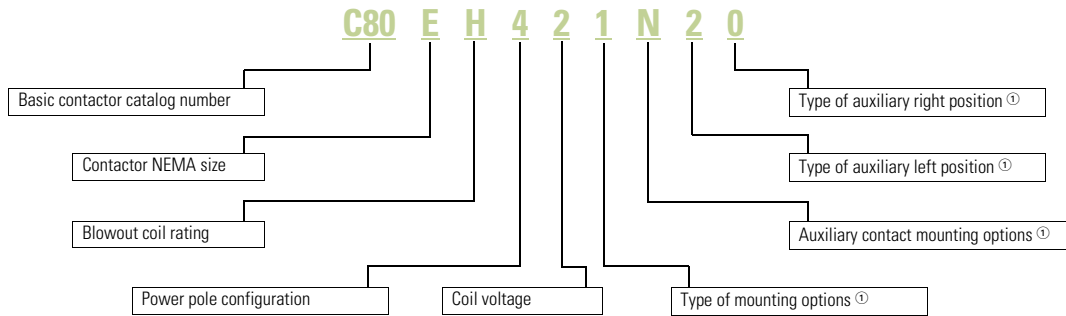

Product Selection

When Ordering Specify

- The catalog number with any required accessories

DC Mill Type Contactors

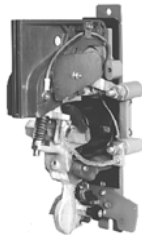

DC Mill Type Contactors

| NEMA Size | Open Type Contactors | | | 100V Coil Catalog Number | Mechanical Interlock Catalog Number |
|-----------------|----------------------|----------------------------|--------------------------|--------------------------|-------------------------------------|
| | Number of Poles | Blowout Coil Ampere Rating | 230V Coil Catalog Number | | |
| 2 | 1NO | None | C80DX12 | C80DX14 | C81DDA11 |
| | | 5 | C80DC12 | C80DC14 | C81DDA11 |
| | | 25 | C80DF12 | C80DF14 | C81DDA11 |
| | | 50 | C80DG12 | C80DG14 | C81DDA11 |
| | 2NO | None | C80DX22 | C80DX24 | C81DDA12 |
| | | 50 | C80DG22 | C80DG24 | C81DDA12 |
| 3 | 1NO | 100 | C80EH121 | C80EH141 | C81DEA11 |
| | 1NC | 100 | C80EH421 | C80EH441 | — |
| 4 | 1NO | 150 | C80FJ121 | C80FJ141 | C81DEA11 |
| | 1NC | 150 | C80FJ421 | C80FJ441 | — |
| 5 | 1NO | 300 | C80GK121 | C80GK141 | C81DGA11 |
| | 1NC | 300 | C80GK421 | C80GK441 | — |
| 6 | 1NO | 600 | C80JL121 | C80JL141 | C81DJA11 |
| | 1NC | 600 | C80JL421 | C80JL441 | — |
| 6A ^② | 1NO | 810 | C80KM121 | C80KM141 | C81DJA11 |
| 8 | 1NO | 1350 | C80WN121 | C80WN141 | C81DLA11 |

Magnet Coil Suffix

| DC Coil Voltage | Coil Suffix | DC Coil Voltage | Coil Suffix |
|-----------------|-------------|----------------------|-------------|
| 115V | 1 | No Coil | 5 |
| 230V | 2 | Special ^③ | 9 |
| 100V | 4 | | |

Notes

- ^① See Page V5-T4-69 for options.
- ^② Not a NEMA size.
- ^③ Consult factory.

Accessories

Auxiliary Contacts with Mounting Kit

| Mounting Location | Contact Arrangement | Contact Size | Catalog Number |
|-------------------|---------------------|----------------|----------------|
| Side | 1NO, 1NC | 2 | C81BAC1 |
| Bottom | 1NO, 1NC | 2 | C81BBC1 |
| | | 3, 4, 5, 6, 6A | C81BBC2 |

Rectifier Module

| Description | Contact Size | Catalog Number |
|-------------------------------|--------------|----------------|
| 120 Vac Input, 100 Vdc Output | All | C81EB |

Options

Auxiliary Contact Mounting Material Options

| Contact Size | Location | Suffix |
|--------------|--|----------|
| 2 | Side | A |
| 2 | Bottom, with left hand and right hand option | B |
| 2 | Bottom, with left hand or right hand option | C |
| 3-8 | Bottom, with left hand and right hand option | B |
| 2-8 | None | N |

Auxiliary Contact Options per Side

| Configuration | Suffix |
|---------------|----------|
| 1NO | 1 |
| 2NO | 2 |
| 1NO-1NC | 3 |
| 1NC | 4 |
| 2NC | 5 |
| None | 0 |

Mounting Kit Options ^①

| Description | Suffix |
|--------------------------------|-----------------------|
| Surface—Front of panel wiring | 1 |
| Elevated—Front of panel wiring | 3 ^② |

Technical Data and Specifications

Mill Type Contactors

| Description | Specification |
|-----------------|----------------------|
| Current range | 5-1800 amperes |
| Voltage | 115, 230 and 550 Vdc |
| Mechanical life | 20M operations |
| Electrical life | 500K operations |

Notes

- ① Solderless lugs available, consult factory.
- ② Not available with Size 2.

600V Contactors

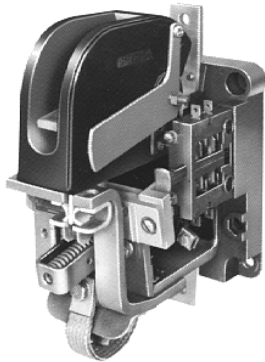

4

Contents

| <i>Description</i> | <i>Page</i> |
|--------------------------------------|-----------------|
| Mill Type Contactors | V5-T4-67 |
| 600V Contactors | |
| Product Selection | V5-T4-71 |
| Accessories | V5-T4-72 |
| Renewal Parts | V5-T4-73 |
| Dimensions | V5-T4-73 |
| DPM 750V Contactor | V5-T4-74 |
| AVD-Contactor | V5-T4-77 |
| D-Contactor | V5-T4-80 |
| Reversing/Assignment Contactor | V5-T4-83 |

600V Contactors

Product Description

These DC Contactors are designed to handle rugged DC applications. They provide durable service and easy installation and maintenance.

Application Description

- Applications including mining, milling, cranes and transportation
- These contactors utilize DC coils

Note: Be sure to utilize a rectifier module if the only control voltage source available is 120 Vac.

Features

- Sturdy glass polyester base
- Knife edge bearings that guarantee precise operation and minimal wear
- High contact pressure
- Vacuum impregnated magnetic coil

Benefits

- Able to mount on steel or panels of any material for maximum flexibility
- Front or rear mounting available for convenient installation and maintenance
- Rapid arc quenching to ensure long life
- Easily accessible contact tips to remove and replace

Product Selection

When Ordering Specify

- Catalog number with appropriate coil suffix
- Any required accessories

600V Contactor

600V Contactors



| Size | Open 8 Hour Ampere Rating | Contact Arrangement | Provisions for Interlocks | | Magnet Coil Voltage | Catalog Number |
|------------------------|---------------------------|---------------------|---------------------------|------------|----------------------|------------------------|
| | | | Mechanical | Electrical | | |
| Front Connected | | | | | | |
| 0 | 10 | 1NO | Yes | 4 | 125 Vdc ^① | ME010C |
| | | 2NO | | 2 | | ME020C |
| | | 1NO, 1NC | | 4 | | ME011C |
| | | 1NC | | 2 | | ME001C |
| 1 | 25 | 1NO | Yes | 4 | 125 Vdc ^① | ME110C |
| | | 2NO | | 2 | | ME120C |
| | | 1NO, 1NC | | 4 | | ME111C |
| | | 1NC | | 2 | | ME101C |
| 2 | 50 | 1NO | Yes | 4 | 125 Vdc ^① | ME210C |
| | | 2NO | | 2 | | ME220C |
| | | 1NO, 1NC | | 4 | | ME211C |
| | | 1NC | | 2 | | ME201C |
| 3 | 100 | 1NO | Yes | 4 | 125 Vdc ^① | ME310C |
| | | 2NO | | 2 | | ME320C |
| | | 1NO, 1NC | | 4 | | ME311C |
| | | 1NC | | 2 | | ME301C |
| 4 | 150 | 1NO | Yes | 4 | 125 Vdc ^① | ME410C |
| | | 2NO | | 2 | | ME420C |
| | | 1NO, 1NC | | 4 | | ME411C |
| | | 1NC | | 2 | | ME401C |
| Rear Connected | | | | | | |
| 0-4 | 10-150 | — | — | — | — | ME ^② |

Notes

- ^① Other coil voltages available, see **Page V5-T4-73**. Substitute suffix code of desired voltage for last digit in listed catalog number. Example: ME010B.
- ^② For 10–150A rear connected contactors, order front connected ME contactor above and rear connection kit, catalog number 2184A10G08, (field installed only). See **Page V5-T4-73**.

Accessories

Auxiliary Contacts (Electrical Interlocks)—For Field Installation Only ^①

| Auxiliary Contact Type | Application | Contact Arrangement ^② | Number of Auxiliary Contacts | Auxiliary Contacts Factory Installed ^① Catalog Number | Auxiliary Contacts Unmounted Replacement Only Catalog Number | Mounting and Operating Hardware for New Applications Catalog Number |
|------------------------|---|----------------------------------|------------------------------|---|---|--|
| L46 | ME01 only | NO-FC | 1 | 11A8713G10 | 11A8713G10 | None required |
| | | NC-FC | | 11A8713G09 | 11A8713G09 | None required |
| | ME10 only | NC-FC-OB | 1 | 487B878G01 | 487B878G01 | None required |
| | ME10, ME11, ME20, ME30, ME31, ME40 and ME41 | NO-FC | 1 | 11A8713G09 | 11A8713G09 | None required |
| | | NC-FC | | 11A8713G10 | 11A8713G10 | None required |
| L66 | ME10, ME11, ME20, ME30, ME31, ME40 and ME41 | DB-FC-L | 1 | 659C301G04 | 659C301G04 | None required |
| | | DB-FC-R | | 659C301G05 | 659C301G05 | None required |
| | ME10 Only | DB-FC-L-OB | 1 | 487B878G06 | 487B878G06 | None required |
| | | DB-FC-R-OB | | 487B878G07 | 487B878G07 | None required |

Standard Magnet Coil Suffix

| Voltage | Suffix Code |
|---------------------------|-------------|
| 65 Vdc (ME Size 0-4 only) | A |
| 115 Vdc | B |
| 125 Vdc | C |
| 230 Vdc | D |
| 250 Vdc | E |
| 550 Vdc | F |
| Other | G |

Rear Connector Kit for ME Contactors ^③

| Catalog Number |
|-------------------|
| 2184A10G08 |

Accessory Option

| Description |
|---|
| Rectifier for AC Operation Order by description |

Mechanical Interlocks, Unmounted

| Type | Contactor Type | Size | Contacts | Catalog Number |
|------|----------------|------|----------------|-------------------|
| M-25 | ME | All | 1NO, 1NO + 1NC | 878D400G01 |
| M-25 | ME | All | 2NO, 2NO + 1NC | 878D401G01 |

Notes

- ① For factory installed electrical interlocks, consult factory.
- ② NO = Normally Open, NC = Normally Closed, DB = Delayed Break, FC = Front Connected, L = Left Hand, R = Right Hand, OB = Outboard (for single-pole, Size 2 frame).
- ③ Field installation only.

Renewal Parts

ME Series

Kits

| Description | One NO Pole | | Two NO Poles | | One NC Pole | | One NO/NC Pole | |
|-------------------------|-------------|-------------|--------------|-------------|-------------|-------------|----------------|-------------|
| | Qty. | Part Number | Qty. | Part Number | Qty. | Part Number | Qty. | Part Number |
| Contact kit | 1 | 2184A10G14 | 2 | 2184A10G14 | 1 | 2184A10G14 | 2 | 2184A10G14 |
| Arc box 10/25/50A | 1 | 2184A10G09 | 2 | 2184A10G09 | 1 | 2184A10G09 | 2 | 2184A10G09 |
| Arc box 100/150A | 1 | 2184A10G10 | 2 | 2184A10G10 | 1 | 2184A10G10 | 2 | 2184A10G10 |
| Shunt kit | 1 | 2184A10G21 | 1 | 2184A20G16 | 1 | 2084A01G07 | 1 | 2184A11G07 |
| Armature kit | 1 | 2184A10G19 | 1 | 2184A20G15 | 1 | 2084A01G06 | 1 | 2184A11G06 |
| Blowout Assembly | | | | | | | | |
| 10A | 1 | 2184A10G15 | 1 | 2184A20G11 | 1 | 2184A10G15 | 2 | 2184A10G15 |
| 25A | 1 | 2184A10G16 | 1 | 2184A20G12 | 1 | 2184A10G16 | 2 | 2184A10G16 |
| 50A | 1 | 2184A10G17 | 1 | 2184A20G13 | 1 | 2184A10G17 | 2 | 2184A10G17 |
| 110/150A | 1 | 2184A10G18 | 1 | 2184A20G14 | 1 | 2184A10G18 | 2 | 2184A10G18 |
| Rear conn. kit | 1 | 2184A10G08 | 1 | 2184A10G08 | 1 | 2184A10G08 | 1 | 2184A10G08 |

Coils

| Voltage | Operating Coils | Holding Coils (Lower)—1NO-1NC Contactors Only ^① | |
|----------|-------------------------------|--|----------------------|
| | 10/25/50/100/150 Ampere Sizes | 10/25/50 Ampere Sizes | 100/150 Ampere Sizes |
| | Part Number | Part Number | Part Number |
| 65V | 30B4376G06 | 44A6366G10 | 30B4376G27 |
| 90/92V | 30B4376G25 | 44A6366G12 | 427C048G16 |
| 115V | 30B4376G07 | 44A6366G13 | 30B4376G01 |
| 125V | 30B4376G08 | 44A6366G19 | 30B4376G26 |
| 230/240V | 30B4376G09 | 44A6366G15 | 30B4376G02 |
| 250V | 30B4376G10 | 44A6366G23 | 30B4376G17 |
| 500V | 30B4376G14 | N/A | N/A |
| 550V | 30B4376G11 | 44A6366G18 | 30B4376G03 |

Dimensions

Approximate Dimensions in Inches (mm)

600V Contactors

| Contactor Size | Contact Arrangement | Width | Height | Depth | Shipping Weight Lbs (kg) |
|------------------------|---------------------|--------------|---------------|--------------|--------------------------|
| Front Connected | | | | | |
| 0-2 | 1NO | 3.18 (80.8) | 7.56 (192.0) | 6.81 (173.0) | 8.0 (3.6) |
| | 2NO | 5.53 (140.5) | 6.75 (171.5) | 6.81 (173.0) | 10.0 (4.5) |
| | 1NO, 1NC | 3.67 (93.2) | 12.44 (316.0) | 6.81 (173.0) | 12.0 (5.4) |
| | 1NC | 3.67 (93.2) | 9.57 (243.1) | 6.81 (173.0) | 10.0 (4.5) |
| 3-4 | 1NO | 3.18 (80.8) | 7.78 (197.6) | 6.81 (173.0) | 8.0 (3.6) |
| | 2NO | 5.53 (140.5) | 7.44 (189.0) | 6.81 (173.0) | 10.0 (4.5) |
| | 1NO, 1NC | 3.67 (93.2) | 12.88 (327.2) | 6.81 (173.0) | 12.0 (5.4) |
| | 1NC | 3.67 (93.2) | 9.69 (246.1) | 6.81 (173.0) | 10.0 (4.5) |

Note

^① If lower coils are required, order separately.

DPM 750V Contactor

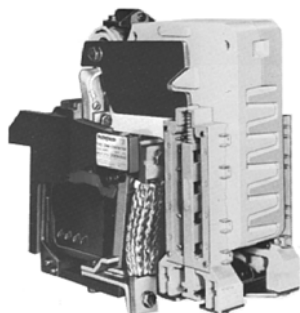

4

DPM 750V Contactor

Product Description

The DPM 750 Vdc Definite Purpose Contactor has been designed to meet severe environmental and vibration conditions found in your worst applications. The contactor is of unit construction, assembled on a molded insulated base, providing maximum performance in minimum space.

Application Description

This rugged device was designed for applications such as railway equipment, offshore drilling, mining, off-road vehicles, marine, and so on.

Features

- Power circuit insulating barriers are molded from glass-polyester materials having high arc and track resisting qualities
- The DPM is designed to mount directly on a channel or angle frame, but may be adapted for mounting on a flat metal or insulated panel
- Available with or without an overcurrent latching mechanism to prevent opening under heavy overload currents. When the line current returns to normal, the overcurrent latch disengages

Benefits

- Saves panel space by locating the arc chute vents on the front of the unit. This eliminates the need for arcing clearance above the contactor
- All vital parts are removable from the front without having to disconnect line or load connections, allowing for easy maintenance
- Safety is a must. The mechanical interlock prevents the contactor from closing when the arc box has been removed or when it is not installed properly

Contents

| <i>Description</i> | <i>Page</i> |
|---|-----------------|
| Mill Type Contactors | V5-T4-67 |
| 600V Contactors | V5-T4-70 |
| DPM 750V Contactor | |
| Product Selection | V5-T4-75 |
| Accessories | V5-T4-75 |
| Renewal Parts | V5-T4-75 |
| Technical Data and Specifications | V5-T4-76 |
| Dimensions | V5-T4-76 |
| AVD-Contactor | V5-T4-77 |
| D-Contactor | V5-T4-80 |
| Reversing/Assignment Contactor | V5-T4-83 |

Product Selection

When Ordering Specify

- Catalog number of contactor and any required accessories

750 Vdc Contactor

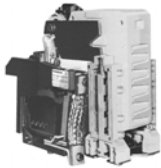

750 Vdc Contactors

| Coil Operating Voltage ① | Over-Current Latch | Catalog Number |
|--------------------------|--------------------|----------------|
| 28 Vdc | Without | 2120A07G01 ② |
| | With | 2120A07G02 ② |
| 36 Vdc | Without | 2120A07G03 ② |
| | With | 2120A07G04 ② |
| 55 Vdc | Without | 2120A07G05 ② |
| | With | 2120A07G06 ② |

| Coil Operating Voltage ① | Over-Current Latch | Catalog Number |
|--------------------------|--------------------|----------------|
| 74 Vdc | Without | 2120A07G09 |
| | With | 2120A07G10 |
| 110 Vdc | Without | 2120A07G13 |
| | With | 2120A07G14 |
| 125 Vdc | Without | 2120A07G17 |
| | With | 2120A07G18 |

Accessories

Extra L-67 Auxiliary Contacts—Order Separately

Contact Combination Provided by One Auxiliary Contact Assembly

| Normally Open | Normally Closed | Field Installed Kit Catalog Number |
|---------------|-----------------|------------------------------------|
| 0 | 4 | 2087A40G11 |
| 1 | 3 | 2087A40G12 |
| 2 | 2 | 2087A40G13 |
| 3 | 1 | 2087A40G14 |
| 4 | 0 | 2087A40G15 |

Mechanical Interlock Kit

| Description | Catalog Number |
|--|----------------|
| Mechanical Horizontal Interlock Kit Includes mounting instructions and mounting hardware ③ | 1954D13G01 |

Renewal Parts

DPM Contactor

| Description | Catalog Number |
|--------------------|----------------|
| Contact Kit | 2131A94G10 |
| Arc Box | 2131A94G03 |
| Shunt | 3534C86G01 |
| Coils | |
| 28 Vdc | 2114A92G04 |
| 36 Vdc | 2114A92G05 |
| 55 Vdc | 2114A92G06 |
| 74 Vdc | 2114A92G09 |
| 110/115 Vdc | 2114A92G14 |
| 125 Vdc | 2114A92G15 |
| 275 Vdc | 2114A92G16 |
| 600 Vdc | 2114A92G20 |

Notes

- ① For other coil operating voltages, contact Eaton Technical Resource Center.
- ② Includes factory installed 2NO/2NC auxiliary contacts.
- ③ When interlock kit is installed, only one L-67 auxiliary contact can be mounted on each DPM contactor.

Technical Data and Specifications

DPM Contactor

| Description | Specification |
|---|--|
| Line voltage | 750 Vdc |
| Continuous current rating | |
| Carrying and interrupting capacity | 1250A |
| Operating coil | |
| Duty rating | Continuous |
| Operation | Will operate at 80–110% of rated voltage |
| Insulation between power circuit and operating coil | Rated 750 Vdc |
| Arcing and creepage distances | Meet or exceed NEMA standards for 750V equipment |
| Blowout coil | Rated for continuous duty |

Dimensions

Approximate Dimensions in Inches (mm)

DPM Contactor

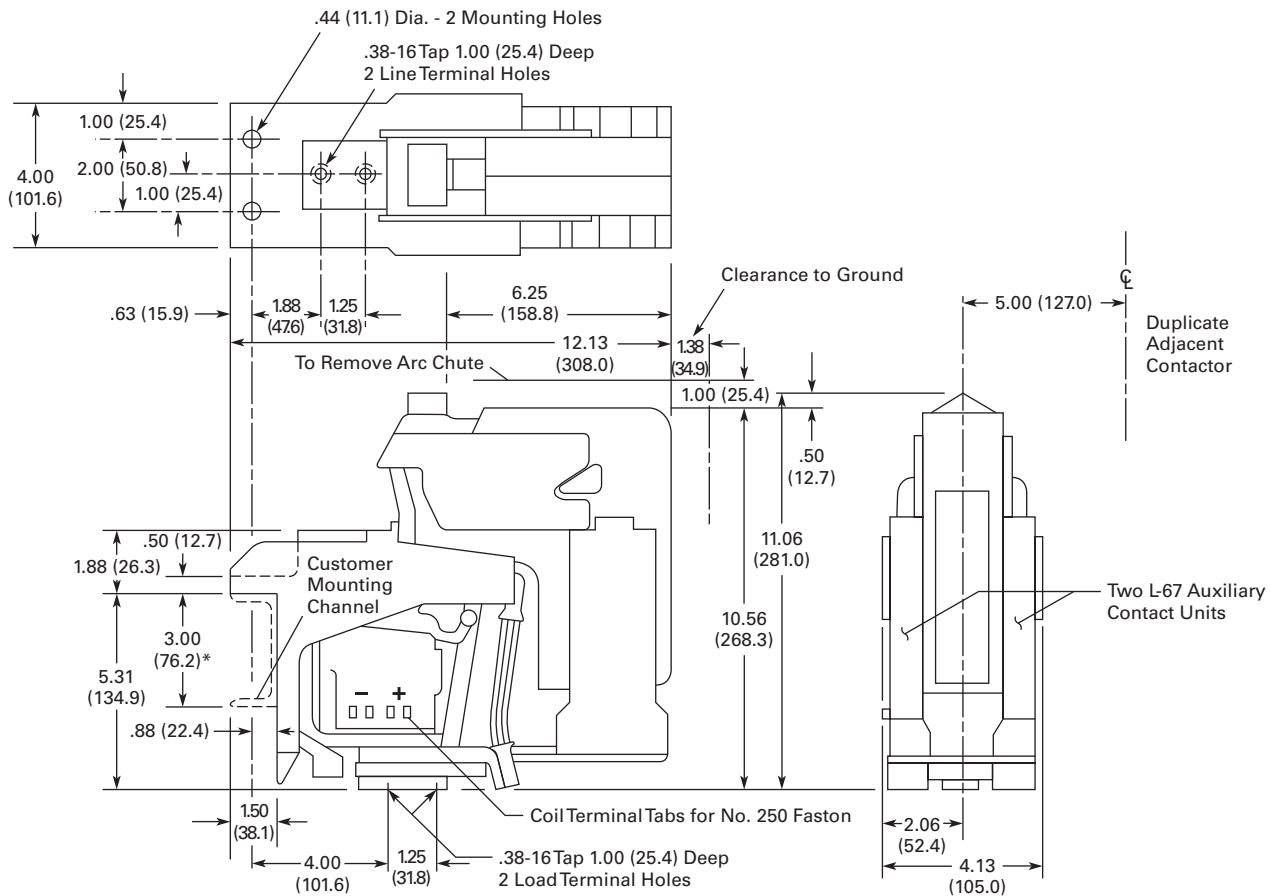

*This dimension must not be exceeded or flashover may occur.

| Width | Height | Depth | Shipping Weight Lbs (kg) |
|------------|---------------|---------------|-----------------------------|
| 4.13 (105) | 11.06 (280.9) | 12.12 (307.8) | 30.5 (13.8) |

AVD-Contactor



Contents

| Description | Page |
|---|-----------------|
| Mill Type Contactors | V5-T4-67 |
| 600V Contactors | V5-T4-70 |
| DPM 750V Contactor | V5-T4-74 |
| AVD-Contactor | |
| Product Selection | V5-T4-78 |
| Accessories | V5-T4-78 |
| Renewal Parts | V5-T4-78 |
| Technical Data and Specifications | V5-T4-79 |
| Dimensions | V5-T4-79 |
| D-Contactor | V5-T4-80 |
| Reversing/Assignment Contactor | V5-T4-83 |

AVD-Contactor

Product Description

The AVD-Contactor is a single-pole normally open, load break, bi-directional definite purpose DC contactor. The device is rated at 1400 amps continuous and is capable of switching up to 2000 Vdc loads.

Application Description

The AVD-Contactor was designed for the demanding environmental requirements of locomotive, rapid transit and off highway vehicle applications. This device is also applied in high horsepower DC drive applications including process lines and off shore oil drilling rigs.

Features

- Bi-directional interrupting capability
- 2000 Vdc switching in a compact design due to arc chute
- Any combination of up to four isolated NO or NC auxiliary contacts
- Panel mount design
- Continuous duty operating coil
- Continuous duty blow out coil

Product Selection**When Ordering—Contact Technical Resource Center**

- Product specification: The AVD-contactor is a definite purpose DC contactor
- Please consult our Technical Resource Center for catalog numbers of other device configurations and application assistance

4

1400A Contactor**AVD—Contactor**

| Device Type | Auxiliary Contact Configuration | Coil Voltage | Catalog Number |
|-----------------|---------------------------------|--------------|--------------------|
| 1400A contactor | 3NO/1NC | 28 | 6702ED667-4 |
| | | 37 | 6702ED667-5 |
| | | 74 | 6702ED667-6 |
| | | 100 | 6702ED667-3 |
| | | 230 | 6702ED667-7 |

Accessories**Auxiliary Contacts**

| Contact Configuration | Terminal Configuration | Catalog Number |
|-----------------------|------------------------|------------------|
| 1NO/1NC | Fast-on | 10-3519-5 |
| 2NO | Fast-on | 10-3519-6 |
| 2NC | Fast-on | 10-3519-7 |
| 1NO/1NC | Screw type | 10-6817 |
| 2NO | Screw type | 10-6817-2 |
| 2NC | Screw type | 10-6817-3 |

Renewal Parts**Contacts**

| Description | Quantity Required per Contactor | Catalog Number |
|--------------------|---------------------------------|----------------|
| Stationary contact | 1 | 23-7253 |
| Movable contact | 2 | 23-7255 |

Technical Data and Specifications

AVD-Contactor

| Description | Specification |
|---|---|
| Current carrying capability at 55°C | 1400A continuous |
| Electrical creepage and clearance distances | Up to 2000 Vdc applications |
| Mechanical life | 2 million operations |
| Operating coil voltages (DC) | 28, 37, 74, 100, 230 (others available) |

Operating Coil Characteristics

| Coil Voltage | Current Draw at Nominal Voltage (±5% at 20°C) | Catalog Number |
|--------------|---|----------------|
| 28 | 1.87 | 9-3004-2 |
| 37 | 1.58 | 9-3004-3 |
| 74 | 0.79 | 9-3004-1 |
| 100 | 0.62 | 9-3004-5 |
| 230 | 0.25 | 9-3004-4 |

Dimensions

Approximate Dimensions in Inches (mm)

AVD-Contactor

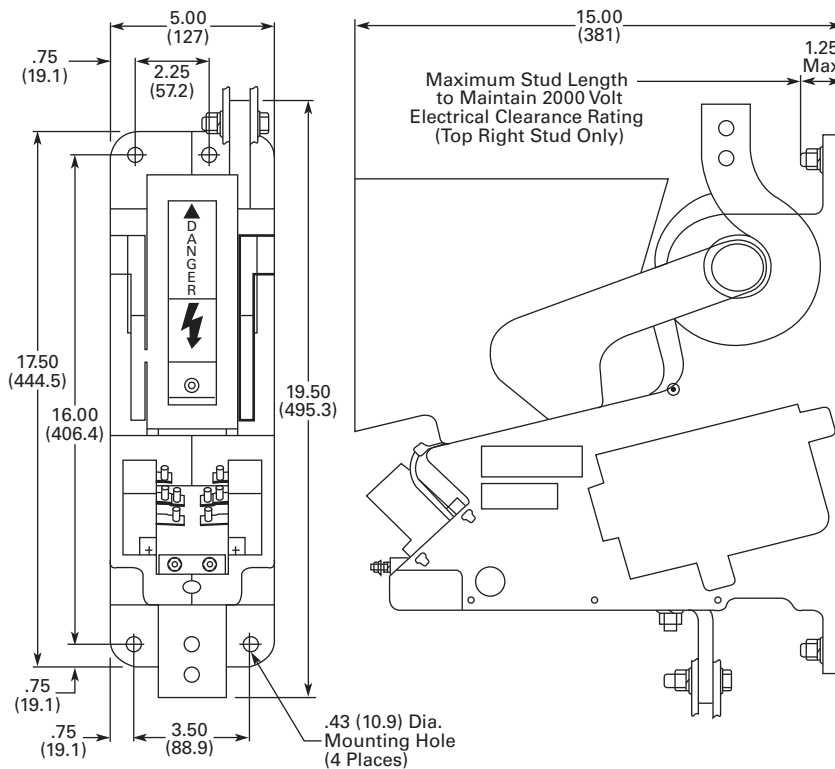

| Width | Height | Depth | Shipping Weight Lbs (kg) |
|--------------|--------------|-------------|-----------------------------|
| 15.0 (381.0) | 19.5 (495.3) | 5.0 (127.0) | 70 (31.8) |

Arc Clearances

| Front | Top | Sides |
|--------|--------|--------|
| 2 (51) | 2 (51) | 1 (25) |

D-Contactor



4

D-Contactor

Product Description

The D-Contactor is a single-pole normally open, load break, bi-directional definite purpose DC contactor. Two devices are available rated at 1800A and 3000A at 750 Vdc.

Application Description

The D-Contactor was designed for the demanding environmental requirements of locomotive, rapid transit and off highway vehicle applications. This device is also widely applied in high horsepower DC drive applications including process lines and off shore oil drilling rigs.

Contents

Description

| Description | Page |
|---|----------|
| Mill Type Contactors | V5-T4-67 |
| 600V Contactors | V5-T4-70 |
| DPM 750V Contactor | V5-T4-74 |
| AVD-Contactor | V5-T4-77 |
| D-Contactor | |
| Product Selection | V5-T4-81 |
| Accessories | V5-T4-81 |
| Renewal Parts | V5-T4-81 |
| Technical Data and Specifications | V5-T4-82 |
| Dimensions | V5-T4-82 |
| Reversing/Assignment Contactor | V5-T4-83 |

Features

Features

- Bi-directional interrupting capability
- Compact design due to intermittent duty blowout coil and arc interruption circuit (not suitable for extremely high duty cycle or jogging applications)
- Any combination of up to eight isolated NO or NC auxiliary contacts
- Channel/angle frame mounting standard, optional panel mount kit available
- Continuous duty operating coil
- Screw type or fast-on control terminals

Product Selection

When Ordering—Contact Technical Resource Center

- Product specification: The D-contactor is a definite purpose DC contactor
- Please consult our Technical Resource Center for catalog numbers of other device configurations and application assistance

1800A Contactor



D-Contactor

| Device Type | Auxiliary Contact Configuration | Coil Voltage | Catalog Number |
|-----------------|---------------------------------|--------------|--------------------|
| 1800A contactor | 3NO/1NC | 74 Vdc | 6702ED584 |
| | 3NO/1NC | 100 Vdc | 6702ED663 |
| | 2NO/2NC | 115 Vdc | 6702ED584-2 |
| 3000A contactor | 3NO/1NC | 74 Vdc | 6702ED587-2 |
| | 2NO/2NC | 100 Vdc | 6702ED668 |
| | 3NO/1NC | 115 Vdc | 6702ED587-4 |

Accessories

Auxiliary Contacts

| Contact Configuration | Terminal Configuration | Catalog Number |
|-----------------------|------------------------|------------------|
| 1NO/1NC | Fast-on | 10-3519-5 |
| 2NO | Fast-on | 10-3519-6 |
| 2NC | Fast-on | 10-3519-7 |
| 1NO/1NC | Screw type | 10-6817 |
| 2NO | Screw type | 10-6817-2 |
| 2NC | Screw type | 10-6817-3 |

Panel Mounting Kit

| Description | Catalog Number |
|--------------------|----------------|
| Panel mounting kit | 99-3842 |

Renewal Parts

Contact Kits

| Device Rating | Main Contact Configuration | Contacts | Catalog Number |
|---------------|----------------------------|-----------------|----------------|
| 1800A | 2-Main | Main contacts | 6-497 |
| 1800A | 2-Main | Arcing contacts | 23-5449 |
| 3000A | 4-Main | Main contacts | 6-496 |
| 3000A | 4-Main | Arcing contacts | 23-5448 |

Technical Data and Specifications

D-Contactor

| Description | Specification |
|---|--|
| Current carrying capability at 55°C | 1800A and 3000A continuous |
| Resistive interrupt rating | 5000A 750 Vdc |
| Electrical creepage and clearance distances | Up to 1500 Vdc applications |
| Mechanical life | 2 million operations |
| Operating coil voltages (DC) | 12, 24, 32, 48, 74, 100, 115, 230 (others available) |

Operating Coil Characteristics

| Coil Voltage | Current Draw at Nominal Voltage (±7.5% at 20°C) | Catalog Number |
|--------------|---|----------------|
| 12 | 3.96 | 9-1688-15 |
| 24 | 2.00 | 9-1688-7 |
| 32 | 1.44 | 9-1688-9 |
| 48 | 1.00 | 9-1688-12 |
| 74 | 0.97 | 9-2064-3 |
| 100 | 0.45 | 9-1688-8 |
| 115 | 0.37 | 9-1688-2 |
| 230 | 0.20 | 9-1688-1 |

Dimensions

Approximate Dimensions in Inches (mm)

D-Contactor

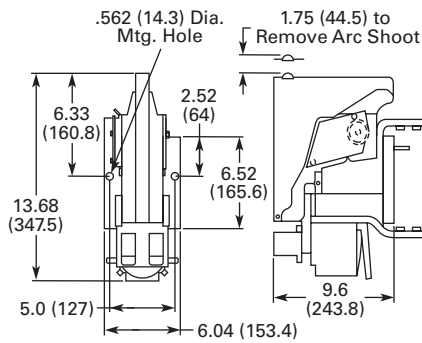

| Width | Height | Depth | Shipping Weight Lbs (kg) |
|-------------|---------------|--------------|-----------------------------|
| 9.6 (243.8) | 13.68 (347.5) | 6.04 (153.4) | 43 (19.5) |

Arc Clearances

| Type of Load | 750V | | |
|--------------|---------|---------|--------|
| | Front | Top | Sides |
| Resistive | 4 (102) | 2 (51) | 3 (76) |
| Inductive | 7 (178) | 4 (102) | 3 (76) |

Reversing/Assignment Contactor

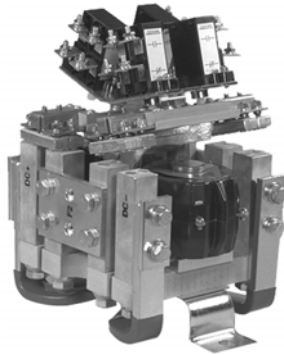

Contents

| Description | Page |
|---|-----------------|
| Mill Type Contactors | V5-T4-67 |
| 600V Contactors | V5-T4-70 |
| DPM 750V Contactor | V5-T4-74 |
| AVD-Contactor | V5-T4-77 |
| D-Contactor | V5-T4-80 |
| Reversing/Assignment Contactor | |
| Product Selection | V5-T4-84 |
| Accessories | V5-T4-84 |
| Renewal Parts | V5-T4-84 |
| Technical Data and Specifications | V5-T4-85 |
| Dimensions | V5-T4-85 |

Reversing/Assignment Contactor

Product Description

The Reversing/Assignment Contactor is a two-pole, double-throw non-load break definite purpose DC contactor. A three-position center-off and a two-position magnetically-latched configuration is available. The device is rated for 1100A, 1000 Vdc. The Reversing Contactor includes cross over busbars for DC motor reversing applications; the Assignment Contactor omits the cross over busbars for motor assignment applications. (See **Page V5-T4-85**.)

Application Description

The Reversing/Assignment Contactor was designed for the demanding environmental requirements of off highway vehicle applications. This device is also widely utilized with high horsepower DC drives for DC motor reversing and drive assignment applications.

Features

- Bi-directional current carrying capability (non-load break)
- Can replace four single-pole contactors in DC motor reversing applications
- Can replace two or four single-pole contactors in DC motor assignment applications
- Any combination of up to eight isolated NO or NC auxiliary contacts
- Panel mount design
- Continuous duty operating coil
- Screw type or fast-on control terminals

Product Selection**When Ordering—Contact Technical Resource Center**

- Product specification: The Reversing/assignment contactor is a definite purpose DC contactor
- Please consult our Technical Resource Center for catalog numbers of other device configurations and application assistance

4

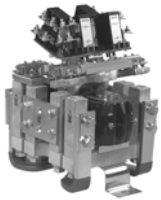
1000V Contactor**Reversing/Assignment Contactor (Three-Position, Center OFF)**

| Device Type | Auxiliary Contact Configuration | Coil Voltage | Catalog Number |
|-------------|---------------------------------|--------------|--------------------|
| Reverser | 8NO | 74 | 6702ED615 |
| | 4NO/4NC | 125 | 6702ED621-2 |
| | | 250 | 6702ED622 |
| Assignment | 4NO/4NC | 74 | 6702ED664-2 |
| | | 125 | 6702ED621 |
| | | 250 | 6702ED664-6 |

Accessories**Auxiliary Contacts**

| Contact Configuration | Terminal Configuration | Catalog Number |
|-----------------------|------------------------|------------------|
| 1NO/1NC | Fast-on | 10-3519-5 |
| 2NO | Fast-on | 10-3519-6 |
| 2NC | Fast-on | 10-3519-7 |
| 1NO/1NC | Screw type | 10-6817 |
| 2NO | Screw type | 10-6817-2 |
| 2NC | Screw type | 10-6817-3 |

Renewal Parts**Contact Kits**

| Device | Configuration | Catalog Number |
|---|----------------|----------------|
| Reversing/assignment | Three-position | 6-602 |
| Reversing/assignment upgrade kit ^① | Three-position | 6-602-3 |
| Magnetic latched reversing/assignment | Two-position | 6-602-5 |

Note

- ^① The 6-602-3 contact kit will upgrade the three-position, reversing/assignment device from the original design that incorporated a leaf spring contact structure to the present design that incorporates a coil spring contact structure. The 6-602 contact kit can then be used after the device has been upgraded for subsequent contact replacement.

Technical Data and Specifications

Reversing/Assignment Contactor

| Description | Specification |
|---|--|
| Current carrying capability at 55°C | 1100A continuous |
| Electrical creepage and clearance distances | For 1000 Vdc applications |
| Mechanical life | 1 million operations |
| Operating coil voltages (DC) | 24, 28, 36, 74, 110, 125, 250 (others available) |

Operating Coil Characteristics

| Coil Voltage | Current Draw at Nominal Voltage (±7.5% at 20°C) | Catalog Number |
|--------------|---|----------------|
| 24 | 1.60 | 9-1903-9 |
| 28 | 1.30 | 9-1903-1 |
| 36 | 1.06 | 9-1903-3 |
| 74 | 0.49 | 9-1903-7 |
| 110 | 0.33 | 9-1903-6 |
| 125 | 0.33 | 9-1903-4 |
| 250 | 0.17 | 9-1903-8 |

Reversing Contactor Schematic Diagram

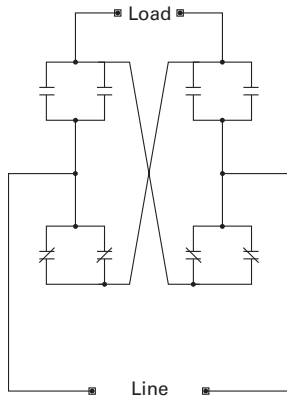

The reversing contactor includes the cross over busbars for DC motor reversing applications. The assignment contactor omits the cross over busbars for motor assignment applications.

Dimensions

Approximate Dimensions in Inches (mm)

Reversing Contactor

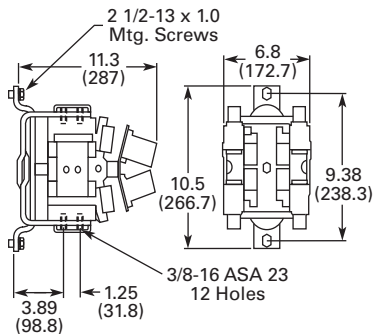

| Width | Height | Depth | Shipping Weight Lbs (kg) |
|------------|--------------|-------------|-----------------------------|
| 11.3 (287) | 10.5 (266.7) | 6.8 (172.7) | 45 (20.4) |

Ampere Rating of AC Motors

Ampere ratings of motors vary somewhat, depending upon the type of motor. The values given below are for drip-proof, Class B insulated (T Frame) where available, 1.15 service factor, NEMA Design B motors. These values represent an average

full load motor current which was calculated from the motor performance data published by several motor manufacturers. In the case of high torque squirrel cage motors, the ampere ratings will be at least 10% greater than the values given below.

Caution—These average ratings could be high or low for a specific motor and therefore heater coil selection on this basis always involves risk. For fully reliable motor protection, select heater coils on the basis of full load current rating as shown on the motor nameplate.

Ampere Ratings of Three-Phase, 60 Hz, AC Induction Motor

| hp ^① | Syn. Speed RPM | Current in Amperes | | | | | |
|-----------------|-------------------|--------------------|------|-------------------|------|------|-------|
| | | 200V | 230V | 380V ^② | 460V | 575V | 2200V |
| 1/4 | 1800 | 1.09 | 0.95 | 0.55 | 0.48 | 0.38 | — |
| | 1200 | 1.61 | 1.4 | 0.81 | 0.7 | 0.56 | — |
| | 900 | 1.84 | 1.6 | 0.93 | 0.8 | 0.64 | — |
| 1/3 | 1800 | 1.37 | 1.19 | 0.69 | 0.6 | 0.48 | — |
| | 1200 | 1.83 | 1.59 | 0.92 | 0.8 | 0.64 | — |
| | 900 | 2.07 | 1.8 | 1.04 | 0.9 | 0.72 | — |
| 1/2 | 1800 | 1.98 | 1.72 | 0.99 | 0.86 | 0.69 | — |
| | 1200 | 2.47 | 2.15 | 1.24 | 1.08 | 0.86 | — |
| | 900 | 2.74 | 2.38 | 1.38 | 1.19 | 0.95 | — |
| 3/4 | 1800 | 2.83 | 2.46 | 1.42 | 1.23 | 0.98 | — |
| | 1200 | 3.36 | 2.92 | 1.69 | 1.46 | 1.17 | — |
| | 900 | 3.75 | 3.26 | 1.88 | 1.63 | 1.3 | — |
| 1 | 3600 | 3.22 | 2.8 | 1.7 | 1.4 | 1.12 | — |
| | 1800 | 4.09 | 3.56 | 2.06 | 1.78 | 1.42 | — |
| | 1200 | 4.32 | 3.76 | 2.28 | 1.88 | 1.5 | — |
| | 900 | 4.95 | 4.3 | 2.6 | 2.15 | 1.72 | — |
| 1-1/2 | 3600 | 5.01 | 4.36 | 2.64 | 2.18 | 1.74 | — |
| | 1800 | 5.59 | 4.86 | 2.94 | 2.43 | 1.94 | — |
| | 1200 | 6.07 | 5.28 | 3.2 | 2.64 | 2.11 | — |
| | 900 | 6.44 | 5.6 | 3.39 | 2.8 | 2.24 | — |
| 2 | 3600 | 6.44 | 5.6 | 3.39 | 2.8 | 2.24 | — |
| | 1800 | 7.36 | 6.4 | 3.87 | 3.2 | 2.56 | — |
| | 1200 | 7.87 | 6.84 | 4.14 | 3.42 | 2.74 | — |
| | 900 | 9.09 | 7.9 | 4.77 | 3.95 | 3.16 | — |
| 3 | 3600 | 9.59 | 8.34 | 5.02 | 4.17 | 3.34 | — |
| | 1800 | 10.8 | 9.4 | 5.7 | 4.7 | 3.76 | — |
| | 1200 | 11.7 | 10.2 | 6.2 | 5.12 | 4.1 | — |
| | 900 | 13.1 | 11.4 | 6.9 | 5.7 | 4.55 | — |
| 5 | 3600 | 15.5 | 13.5 | 8.2 | 6.76 | 5.41 | — |
| | 1800 | 16.6 | 14.4 | 8.74 | 7.21 | 5.78 | — |
| | 1200 | 18.2 | 15.8 | 9.59 | 7.91 | 6.32 | — |
| | 900 | 18.3 | 15.9 | 9.6 | 7.92 | 6.33 | — |

Notes

- ① To convert horsepower to kW, multiply horsepower by 0.7457.
- ② 380V 50 Hz.

Ampere Ratings of Three-Phase, 60 Hz, AC Induction Motor, continued

| hp ^① | Syn. Speed RPM | Current in Amperes | | | | | |
|-----------------|-------------------|--------------------|------|-------------------|------|------|-------|
| | | 200V | 230V | 380V ^② | 460V | 575V | 2200V |
| 7-1/2 | 3600 | 22.4 | 19.5 | 11.8 | 9.79 | 7.81 | — |
| | 1800 | 24.7 | 21.5 | 13 | 10.7 | 8.55 | — |
| | 1200 | 25.1 | 21.8 | 13.2 | 10.9 | 8.7 | — |
| | 900 | 26.5 | 23 | 13.9 | 11.5 | 9.19 | — |
| 10 | 3600 | 29.2 | 25.4 | 15.4 | 12.7 | 10.1 | — |
| | 1800 | 30.8 | 26.8 | 16.3 | 13.4 | 10.7 | — |
| | 1200 | 32.2 | 28 | 16.9 | 14 | 11.2 | — |
| | 900 | 35.1 | 30.5 | 18.5 | 15.2 | 12.2 | — |
| 15 | 3600 | 41.9 | 36.4 | 22 | 18.2 | 14.5 | — |
| | 1800 | 45.1 | 39.2 | 23.7 | 19.6 | 15.7 | — |
| | 1200 | 47.6 | 41.4 | 25 | 20.7 | 16.5 | — |
| | 900 | 51.2 | 44.5 | 26.9 | 22.2 | 17.8 | — |
| 20 | 3600 | 58 | 50.4 | 30.5 | 25.2 | 20.1 | — |
| | 1800 | 58.9 | 51.2 | 31 | 25.6 | 20.5 | — |
| | 1200 | 60.7 | 52.8 | 31.9 | 26.4 | 21.1 | — |
| | 900 | 63.1 | 54.9 | 33.2 | 27.4 | 21.9 | — |
| 25 | 3600 | 69.9 | 60.8 | 36.8 | 30.4 | 24.3 | — |
| | 1800 | 74.5 | 64.8 | 39.2 | 32.4 | 25.9 | — |
| | 1200 | 75.4 | 65.6 | 39.6 | 32.8 | 26.2 | — |
| | 900 | 77.4 | 67.3 | 40.7 | 33.7 | 27 | — |
| 30 | 3600 | 84.8 | 73.7 | 44.4 | 36.8 | 29.4 | — |
| | 1800 | 86.9 | 75.6 | 45.7 | 37.8 | 30.2 | — |
| | 1200 | 90.6 | 78.8 | 47.6 | 39.4 | 31.5 | — |
| | 900 | 94.1 | 81.8 | 49.5 | 40.9 | 32.7 | — |
| 40 | 3600 | 111 | 96.4 | 58.2 | 48.2 | 38.5 | — |
| | 1800 | 116 | 101 | 61 | 50.4 | 40.3 | — |
| | 1200 | 117 | 102 | 61.2 | 50.6 | 40.4 | — |
| | 900 | 121 | 105 | 63.2 | 52.2 | 41.7 | — |
| 50 | 3600 | 138 | 120 | 72.9 | 60.1 | 48.2 | — |
| | 1800 | 143 | 124 | 75.2 | 62.2 | 49.7 | — |
| | 1200 | 145 | 126 | 76.2 | 63 | 50.4 | — |
| | 900 | 150 | 130 | 78.5 | 65 | 52 | — |
| 60 | 3600 | 164 | 143 | 86.8 | 71.7 | 57.3 | — |
| | 1800 | 171 | 140 | 90 | 74.5 | 59.4 | — |
| | 1200 | 173 | 150 | 91 | 75 | 60 | — |
| | 900 | 177 | 154 | 93.1 | 77 | 61.5 | — |
| 75 | 3600 | 206 | 179 | 108 | 89.6 | 71.7 | — |
| | 1800 | 210 | 183 | 111 | 91.6 | 73.2 | — |
| | 1200 | 212 | 184 | 112 | 92 | 73.5 | — |
| | 900 | 222 | 193 | 117 | 96.5 | 77.5 | — |

Notes

- ① To convert horsepower to kW, multiply horsepower by 0.7457.
- ② 380V 50 Hz.

Ampere Ratings of Three-Phase, 60 Hz, AC Induction Motor, continued

| hp ^① | Syn. Speed RPM | Current in Amperes | | | | | |
|-----------------|-------------------|--------------------|------|-------------------|------|------|-------|
| | | 200V | 230V | 380V ^② | 460V | 575V | 2200V |
| 100 | 3600 | 266 | 231 | 140 | 115 | 92.2 | — |
| | 1800 | 271 | 236 | 144 | 118 | 94.8 | 23.6 |
| | 1200 | 275 | 239 | 145 | 120 | 95.6 | 24.2 |
| | 900 | 290 | 252 | 153 | 126 | 101 | 24.8 |
| 125 | 3600 | — | 292 | 176 | 146 | 116 | — |
| | 1800 | — | 293 | 177 | 147 | 117 | 29.2 |
| | 1200 | — | 298 | 180 | 149 | 119 | 29.9 |
| | 900 | — | 305 | 186 | 153 | 122 | 30.9 |
| 150 | 3600 | — | 343 | 208 | 171 | 137 | — |
| | 1800 | — | 348 | 210 | 174 | 139 | 34.8 |
| | 1200 | — | 350 | 210 | 174 | 139 | 35.5 |
| | 900 | — | 365 | 211 | 183 | 146 | 37 |
| 200 | 3600 | — | 452 | 257 | 226 | 181 | — |
| | 1800 | — | 458 | 265 | 229 | 184 | 46.7 |
| | 1200 | — | 460 | 266 | 230 | 184 | 47 |
| | 900 | — | 482 | 279 | 241 | 193 | 49.4 |
| 250 | 3600 | — | 559 | 338 | 279 | 223 | — |
| | 1800 | — | 568 | 343 | 284 | 227 | 57.5 |
| | 1200 | — | 573 | 345 | 287 | 229 | 58.5 |
| | 900 | — | 600 | 347 | 300 | 240 | 60.5 |
| 300 | 1800 | — | 678 | 392 | 339 | 271 | 69 |
| | 1200 | — | 684 | 395 | 342 | 274 | 70 |
| 400 | 1800 | — | 896 | 518 | 448 | 358 | 91.8 |
| 500 | 1800 | — | 1110 | 642 | 555 | 444 | 116 |

Notes

① To convert horsepower to kW, multiply horsepower by 0.7457.

② 380V 50 Hz.