

Safety Interlock Switches

CM Series



Most Diverse and Flexible Line of Coded Magnetic Safety Interlock Switches and Controllers

- Combine door switch monitoring and E-stop monitoring by using the CM-S41 controller
- Monitor is single switch to CAT4 with the CM-S30 controller
- Monitor multiple switches to CAT3 using CM-S4 or CM-S30 controllers
- Monitoring multiple switches on individual channels can be achieved by using the CM-S21 or CM-S41 controllers. Easily expand your system by using the CM-SE expansion module.
- All CM switches are rated IP67
- Stainless steel switches are available for harsh environments



Conforms to EN292, EN60204-1, EN954-1, EN1088, EN60947-5-3, EN947-5-3, EN50081, EN50082, EN61000-6-2, ISO 13849-1
UL and C-UL listed, TUV certified

G

Description

The CM series of controllers and coded magnetic switches offers the most flexibility and widest range of options available. The CM series is comprised of two basic technologies.

Controller Technologies

2-Wire Single Channel Controllers

The CM-S41 and CM-S21 controllers monitor the 2-wire magnetically coded switches. The CM-S41 and CM-S21 controllers use a patented technology which allows them to monitor the 2-wire or single channel switches up to Category 3. The ability to monitor just a single channel enables the CM-S41 and CM-S21 to easily monitor multiple switches and provide individual status of each channel. Both of these controllers are compatible with the CM-SE expansion module.

Dual Channel Controllers

The CM-S4 and CM-S30 controllers are designed to monitor conventional read-style, magnetically-coded switches with 1 N/O + 1 N/C contacts. The CM-S4 controller can monitor up to four switches to category 3. The CM-S4 controller offers status indication for each individual switch. The CM-S30 controller can monitor one switch to category 4, or two switches to category 3. The CM-S30 control unit is capable of monitoring up to 30 conventional read style switches in series, but does not conform to category 3 when used with more than two switches.

Switch Categories

The CM series of switches are all magnetically coded. The CM series of switches fall into three main categories:

1. 2-wire Coded Magnetic
2. Conventional Read Style 1 N/C + 1 N/O contacts
3. Universal Read Style 2 N/C + 1 N/O contacts

The 2-wire Coded Magnetic Switches are only compatible with the CM-S21, CM-S41 and CM-SE control units and expansion module. The Conventional Read Style Switches are compatible with the CM-S4 and CM-S30 controllers. The Universal Read Style Switches are unique in design, all three contacts are rated for safety. This means that Universal Read Style switches can be used with the CM-S4 or CM-S30 Controllers, or conventional safety monitoring relays such as the G9SA, SR103 or G9SX-AD, -BC. This allows the Universal Read Style Switches to be run in series with E-stop switches or other mechanical door switches. Typically a category 2 rating would be applied to a system that incorporates multiple switches wired in series to a standard safety monitoring relay. A risk assessment should always be performed by properly trained and authorized personnel.

Switch Specifications

Electrical	CM-S1, CM-S2, CM-S3	CM-S5, CM-S6	CM-S221, CM-S521, CM-S621	CM-S11	CM-S31	CM-S321, CM-S421
Safety Contacts:	1 N/C + 1 N/O	1 N/C + 1 N/O	2 N/C + 1 N/O	Current Sensing Circuit	Current Sensing Circuit	2 N/C + 1 N/O
N/C Operating Distance:	CM-S1 — On = 3 mm; Off = 8 mm CM-S2 and CM-S3 — On = 6 mm; Off = 13 mm	On = 7 mm; Off = 10 mm	On = 7 mm; Off = 10 mm	On = 5-7 mm; Off = 8-12 m	On = 5-7 mm; Off = 8-12 mm	On = 7 mm; Off = 10 mm
Minimum Gap:	1 mm	1 mm	1 mm	1 mm	1 mm	1 mm
Max Switched Current/Voltage:	500 mA / 24 V	300 mA / 24 V	300 mA / 24 V			300 mA / 24 V
Mechanical						
Mounting:	2 x M4 screws supplied	2 x M4 screws supplied	2 x M4 screws supplied	2 x M4 screws supplied	2 x M4 screws supplied	3 x M4 screws supplied
Case Material:	Glass filled PPS	ABS	ABS	ABS	316 stainless steel	316 stainless steel
Max Wire Size:	Pre-wired cable to 5 m	Pre-wired cable to 10 m	Pre-wired cable to 10 m	Pre-wired cable to 10 m	Pre-wired cable to 10 m	Pre-wired cable to 5 m, 6-pin micro AC connector
Weight:	230 g (8.1 oz.)	207 g (8.1 oz.)	230 g (8.1 oz.)	207 g (7.3 oz.)	265 g (9.3 oz.)	545 g (19.2 oz.)
Color:	Red	Red	Red	Red	Stainless	Stainless
Mechanical Life:	10 ⁶	10 ⁶	10 ⁶	10 ⁶	10 ⁶	10 ⁶
Environmental						
Protection:	IP67 (NEMA 6)	IP67 (NEMA 6)	IP67 (NEMA 6)	IP67 (NEMA 6)	IP67 (NEMA 6)	IP67 (NEMA 6)
Operating Temperature:	-10 to 55°C (14 to 131°F)	-10 to 55°C (14 to 131°F)	-10 to 55°C (14 to 131°F)	-10 to 55°C (14 to 131°F)	-10 to 55°C (14 to 131°F)	Connector Models: -10 to 55°C (14 to 131°F) Integrated Cables: -10 to 95°C (14 to 203°F)
Humidity:	95% RH at 55°C (131°F)					
Compliance						
Standards:	EN292, EN60204-1, EN954-1, EN1088, EN60947-5-3, EN947-5-3, EN50081, EN50082, EN61000-6-2					
Approvals/Listings:	CE marked for all applicable directives, UL and C-UL. TUV certified: CM-S1, CM-S2, CM-S3, CM-S11 and CM-S31.					

Specifications are subject to change without notice.

Note: The safety contacts of the Omron STI switches are described as normally closed (N/C) i.e., with the guard closed, actuator in place, and the machine able to be started.

G

Control Unit Specifications

Electrical	CM-S4	CM-S30	CM-S41, CM-S21 & CM-SE
Power Supply:	24 VAC/DC ± 10%	24 VAC/DC ± 10%	CM-S41 — 24 VAC/DC, 110/230 VAC CM-S21 & CM-SE — 24 VAC/DC
Power Consumption:	2.4 VA typical, 0.25 A quick acting	120 mA	CM-S41 — 6 VA; CM-S21 & CM-SE — 3 VA
Input Fuse:	500 mA resettable	750 mA resettable	500 mA resettable
Safety Inputs:	1 N/O + 1 N/C	1 N/O + 1 N/C	CM-S41 — 4 CM-S11 or CM-S31 switches CM-S21 — 2 CM-S11 or CM-S31 switches CM-SE — 5 CM-S11 or CM-S31 switches
Max Cable Length:	—	—	100 m (328 ft.)
Max Input Resistance:	Contact factory	Contact factory	Contact factory
Relay Outputs:	1 N/O safety + 1 N/O aux.	2 N/O safety + 1 N/C aux.	CM-S41 & CM-S21 — 2 N/O; CM-SE — N/A
Max Switched Current/Voltage:	4 A / 24 VAC/DC	3 A / 24 VAC/DC	4 A / 230 VAC; 2 A / 24 VDC (resistive)
Min Switched Current/Voltage:	4 mA / 12 V	4 mA / 12 V	10 V / 10 mA
Impulse Withstand Voltage:	250 V	250 V	250 V
Max Drop-Out Time:	18 ms	18 ms	Deactivation by sensor 13 mS
Max Output Fuse:	4 A quick acting	4 A quick acting	AC = 5 A; DC = 2.5 A; quick acting
Reset Mode:	Automatic	Automatic/Manual, monitored	Monitored manual or automatic
External Device Monitoring:	N/C loop between Y1 and Y2	Between Y1, Y2, Y3	N/C loop between X1 and X2
Mechanical			
Mounting:	35 mm (1.38 in.) DIN rail	35 mm (1.38 in.) DIN rail	35 mm (1.38 in.) DIN rail
Case Material:	Polyamid PA6.6	Polyamid PA6.6	Polycarbonate
Max Wire Size:	2 x 2.5 mm ² (12 AWG)	1 x 2.5 mm ² (14 AWG)	1 x 2.5 mm ² stranded, 1 x 4 mm ² solid
Weight:	240 g (8.5 oz.)	230 g (8.1 oz.)	CM-S41 — 575 g (20.3 oz.) CM-S21 — 183 g (6.5 oz.) CM-SE — 135 g (4.8 oz.)
Color:	Grey	Red/Grey	Red
Indication:	U: Green = On Outputs Open: Red = On Outputs Closed: Green = On D11, D12, D21, D22: Green = Gate closed D31, D32, D41, D42: Red = Gate open	Green = Power On Green = K1 On Green = K2 On	Power = Red Outputs Closed: Green = On Outputs Open: No Light = Off Gate Closed: Yellow = On Gate Open: No Light = Off
Mechanical Life:	3 x 10 ⁷	1 x 10 ⁷	1 x 10 ⁶
Environmental			
Protection:	Housing IP40, Terminals IP20	Housing IP40, Terminals IP20	Housing IP40, Terminals IP20
Operating Temperature:	0 to 50°C (32 to 122°F)	0 to 55°C (32 to 131°F)	10 to 55°C (50 to 131°F)
Humidity:	95%	93%	85%
Compliance			
Standards:	EN292, EN60204-1, ISO 13849-1, EN1088, EN50081, EN50082, EN61000-6-2	EN60947-5-3, EN947-5-3,	EN292, EN60204-1, EN954-1, EN1088, EN60947-5-3, EN947-5-3, EN50081, EN50082, EN61000-6-2
Approvals/Listings:	CE marked for all applicable directives, UL and C-UL, TUV (TUV pending for CM-S30)		
Safety Category:	Cat 3 per EN954-1 (internal operation)	Cat 4 per ISO 13894-1 (internal operation)	Cat 3 per EN954-1 (internal operation)

Specifications are subject to change without notice.

Note: The safety contacts of the Omron STI switches are described as normally closed (N/C) i.e., with the guard closed, actuator in place, and the machine able to be started.

G

Applications

2-Wire Single Channel Controllers

CM-S41 Control Unit

The CM-S41 is a combined Safety Switch and E-Stop control unit. Along with the ability to monitor up to four, 2-wire CM Series safety switches, it can also monitor the normally closed contacts of emergency stop buttons or mechanical safety switches in dual channel control circuits.

The CM-S41 has 2 normally open safety contact outputs and 1 normally closed auxiliary output, an external reset/proving circuit and LED indication for "Power", "Run" and the status of each activated gate switch.

CM-S21 Control Unit

The CM-S21 control unit is a 24 VAC/DC system that can monitor up to 2 CM Series safety switches.

The CM-S21 has 2 normally open safety contact outputs and 1 normally closed auxiliary output, an external reset/proving circuit and LED indication for "Power", "Run" and the status of each activated gate switch.

CM-SE Extender Module

The CM-SE expansion module is a 24 VAC/DC unit that can be added to either the CM-S41 or CM-S21 to monitor an additional 5 CM Series safety switches. Connection to the main control unit is by a simple 2-wire bus connection. The status of each guard switch is shown by the YELLOW LED's. Additional CMSE-E modules can be added to monitor larger systems.



CM-S21 Application Diagram

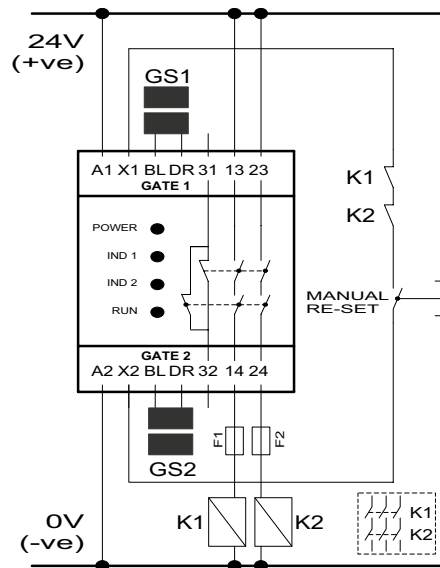

CM-S41 Application Diagram

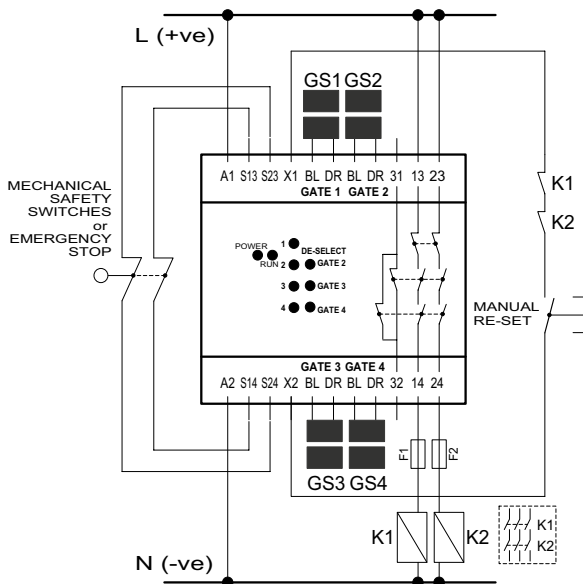

CM-SE Application Diagram

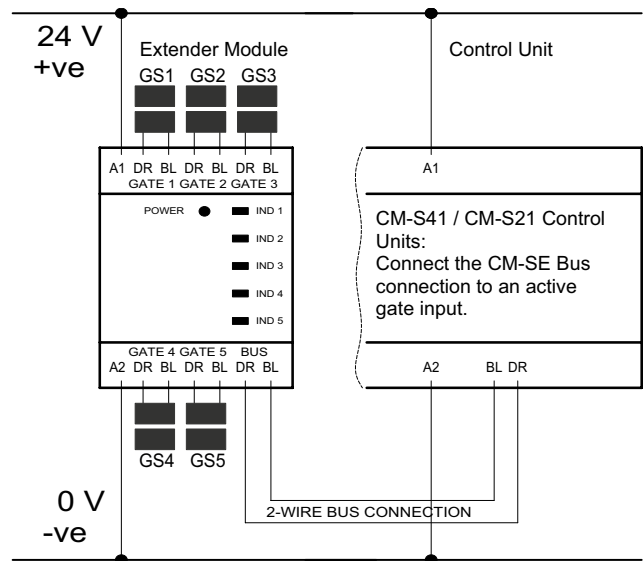

CM-S41 / CM-S21 Control Units:
Connect the CM-SE Bus connection to an active gate input.

Applications (continued)

Dual Channel Controllers

CM-S4 Control Unit

The CM-S4 controller is capable of monitoring up to four, magnetically coded switches with 1 N/O + 1 N/C contacts up to category 3 according to EN954-1. The CM-S4 has a dedicated dual channel input for each switch and has LED status indicators for each channel. The CM-S4 has 1 N/O safety contact and 1 N/C Aux contact. External Device Monitoring (EDM) is available using Y1,Y2 inputs.

CM-S30 Control Unit

The CM-S30 controller is capable of monitoring one magnetically coded switch with 1 N/O + 1 N/C contacts up to category 4, or two switches to category 3 according to ISO 13489-1. The CM-S30 control unit is capable of monitoring up to 30 conventional read style switches in series, but does not conform to category 4 when used with more than two switches. The CM-S30 controller has 2 N/O safety contacts and 1 N/C Auxillary contact. External Device Monitoring (EDM) is available using Y1,Y2 inputs.



G

CM-S4 Application Diagram

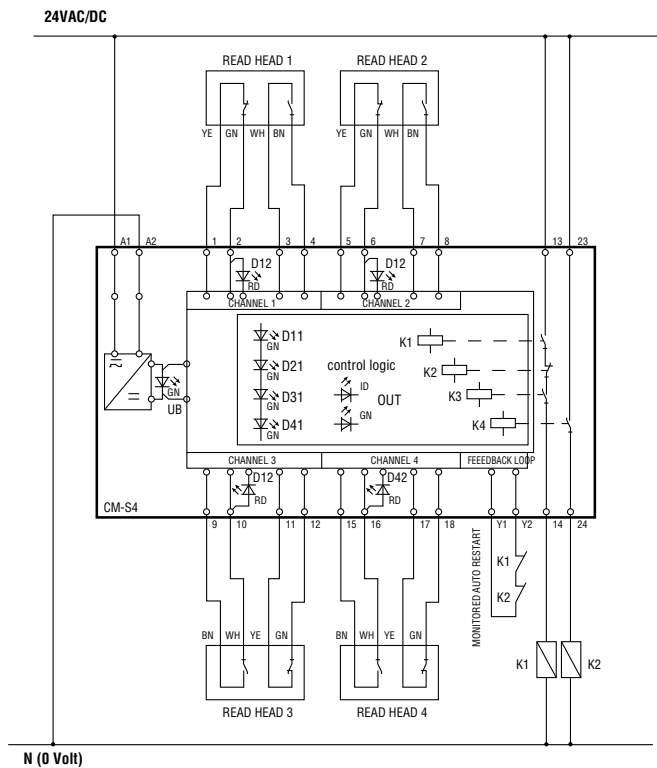

CM-S30 Application Diagram (Cat 3)

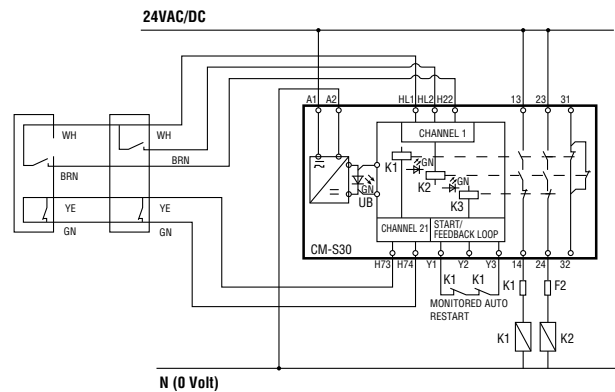

CM-S30 Application Diagram (Cat 4)

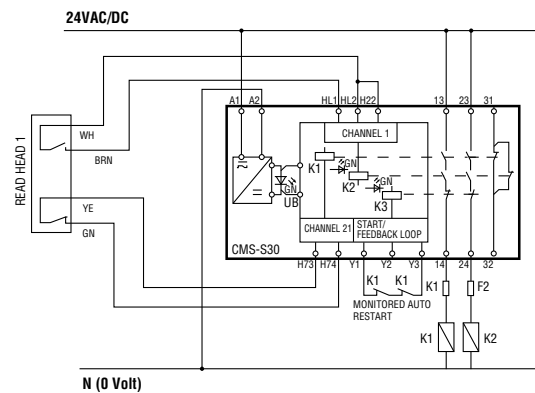

Dimensions

(mm/in.)

2-Wire Coded Magnetic Switches

CM-S11

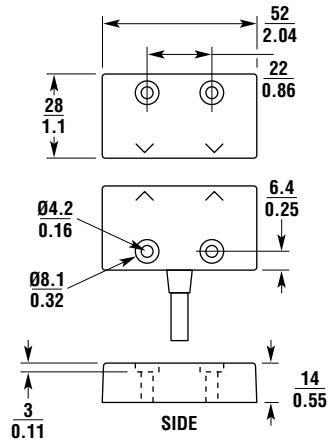

CM-S31

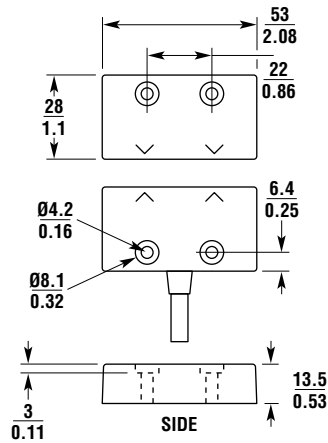

G

Dimensions (continued)

(mm/in.)

Conventional Read Style Switches

CM-S1

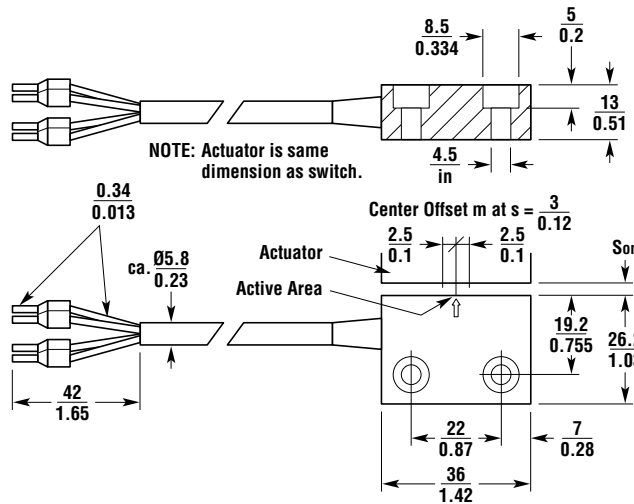

G

CM-S2

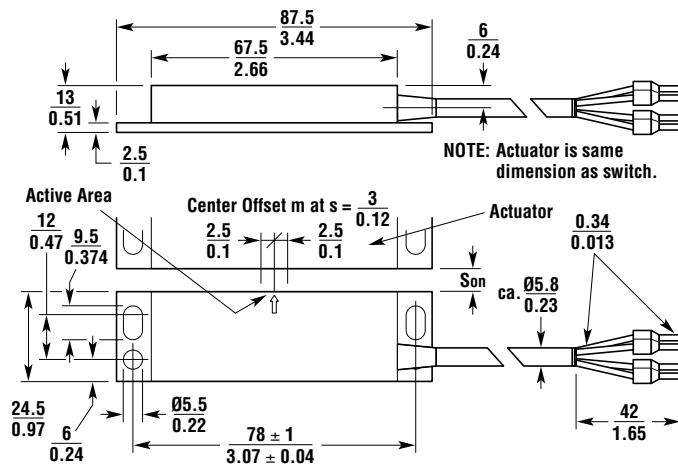

CM-S3

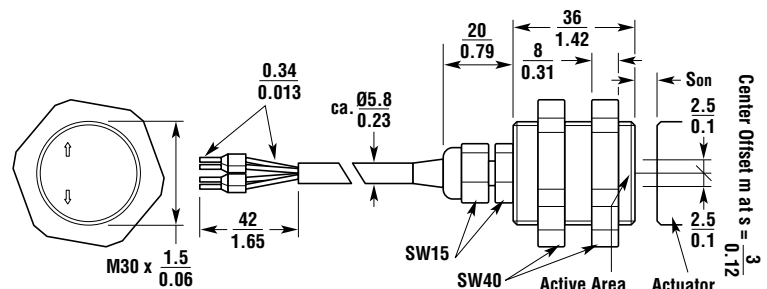

Dimensions (continued)

(mm/in.)

Conventional Read Style Switches (continued)

CM-S5



CM-S5 and CM-S521

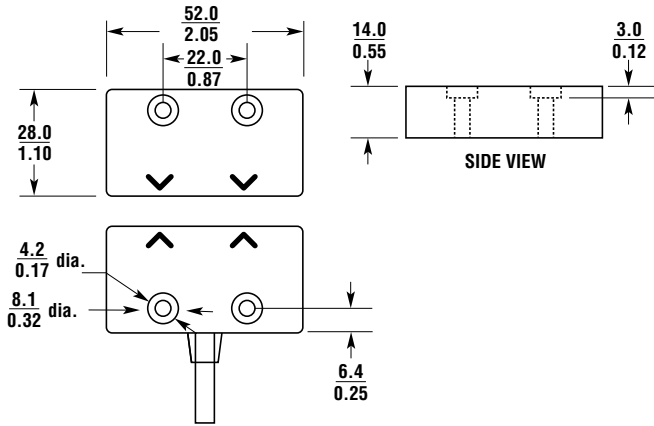

CM-S6



CM-S6 and CM-S621

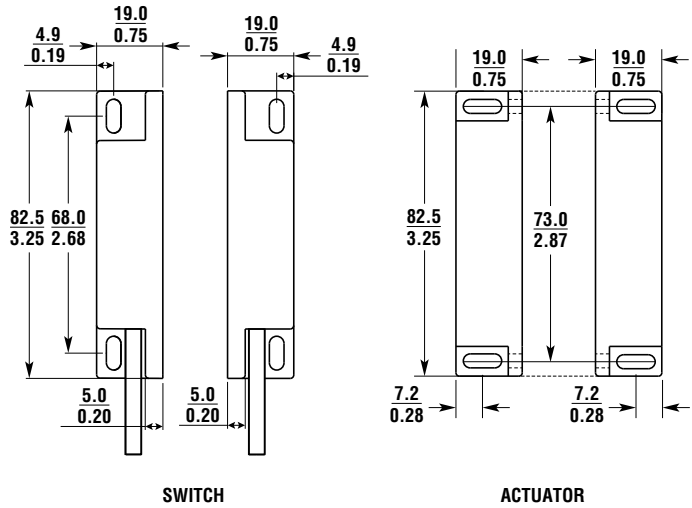

G

Dimensions (continued)

(mm/in.)

Universal Read Style Switches

CM-S221

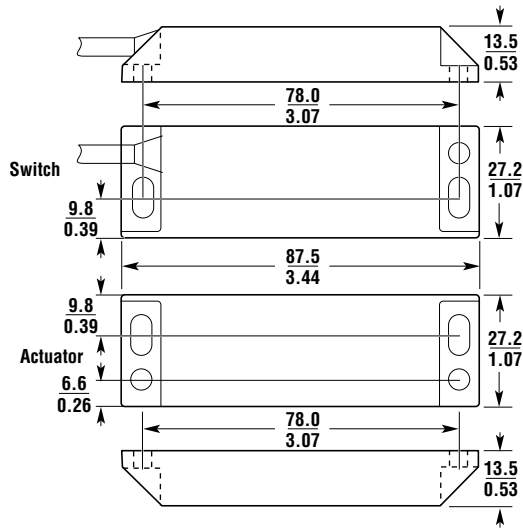

G

CM-S321/CM-S421

CM-S321 and CM-S421

Note: The CM-S321 includes a backing plate (not shown).

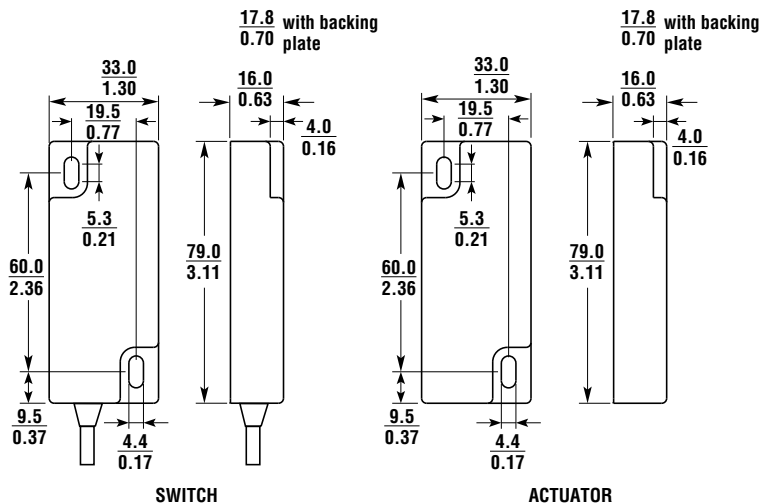



CM-S521



CM-S621



 For CM-S521 dimensions, please refer to the CM-S5 dimensions on the previous page.

 For CM-S621 dimensions, please refer to the CM-S6 dimensions on the previous page.

Dimensions (continued)

(mm/in.)

Control Units

CM-S4

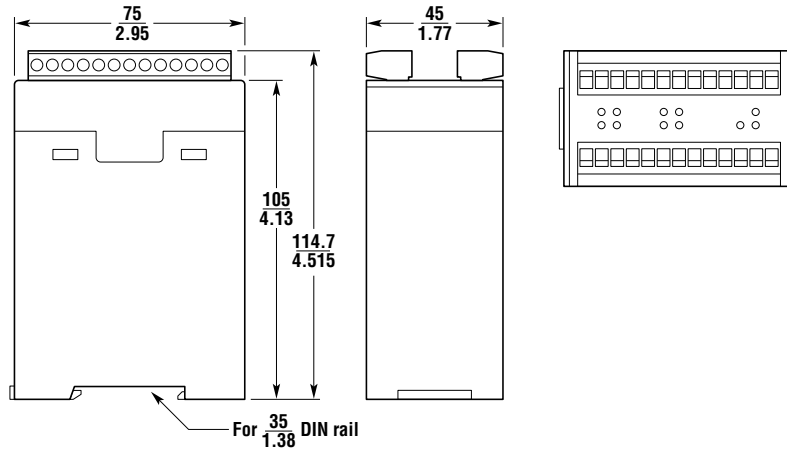

CM-S41

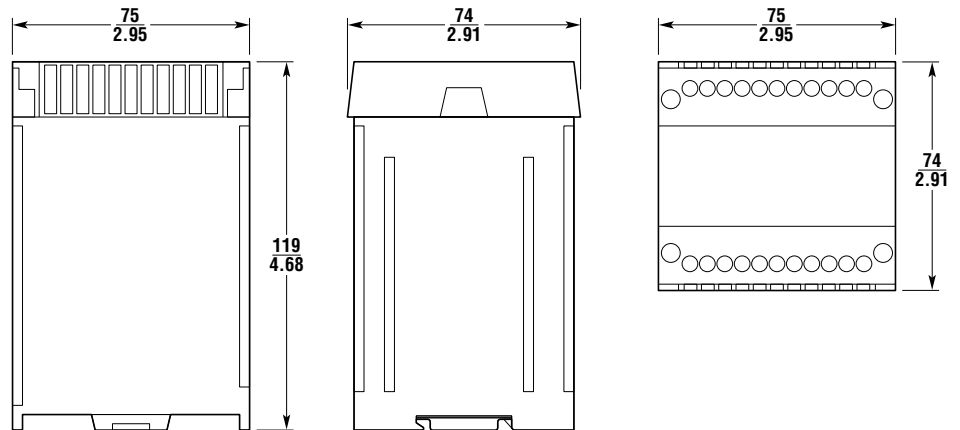

CM-S21 & CM-SE

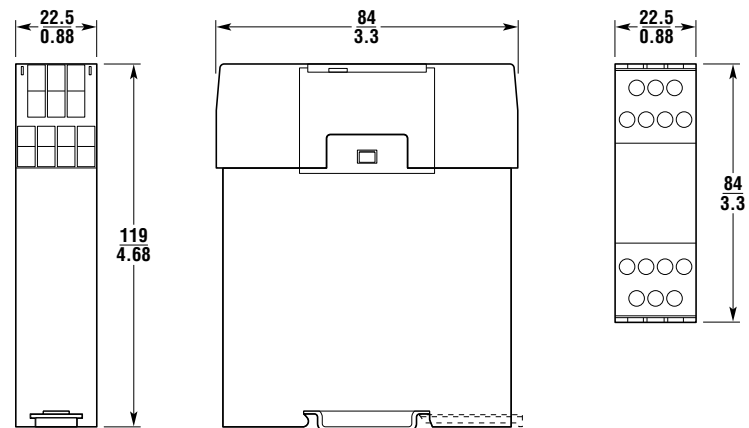

Dimensions (continued)

(mm/in.)

Control Units (continued)

CM-S30

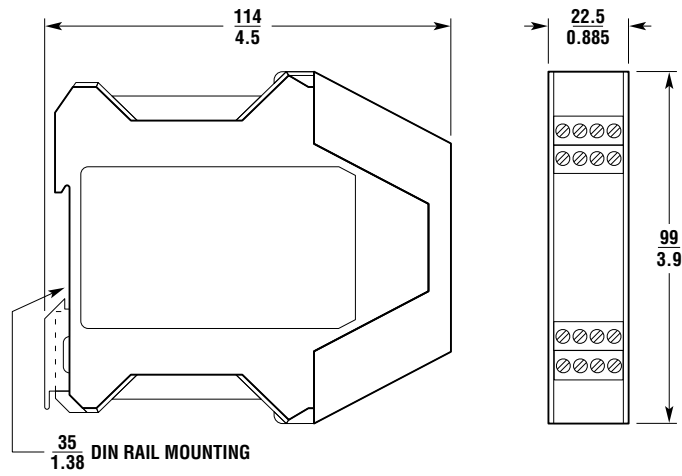

G

Ordering

Model	Switch Construction	Contacts	Wiring Entry	Part No.
Control Units for 2-Wire Switches				
CM-S21-24 (24 VAC/DC)				44536-0120
CM-S41-24 (24 VAC/DC)				44536-0140
CM-S41-110 (110 VAC or 230 VAC)				44536-0141
CM-SE-24 (24 VAC/DC)				44536-0170
2-Wire Switches				
CM-S11-PC3	Plastic	2-wire system	3 m cable	44536-1100
CM-S11-PC5	Plastic	2-wire system	5 m cable	44536-1105
CM-S11-PC10	Plastic	2-wire system	10 m cable	44536-1110
CM-S11-PCC5	Plastic	2-wire system	connector + 5 m cable	44536-1159
CM-S31SC3	Stainless Steel	2-wire system	3 m cable	44536-3100
CM-S31SC5	Stainless Steel	2-wire system	5 m cable	44536-3105
CM-S31SCC5	Stainless Steel	2-wire system	connector + 5 m cable	44536-3159
Control Units for 1 N/C + 1 N/O Reed Style Switches				
CM-S30 (24VAC/DC)				44536-0030
CM-S4 (24VAC/DC)				44536-0040
1 N/C + 1 N/O Reed Style Switches				
CM-S1PC3	Plastic	1 N/C + 1 N/O	3 m cable	44536-0100
CM-S1PC5	Plastic	1 N/C + 1 N/O	5 m cable	44536-0105
CM-S2PC3	Plastic	1 N/C + 1 N/O	3 m cable	44536-0200
CM-S2PC5	Plastic	1 N/C + 1 N/O	5 m cable	44536-0205
CM-S3PC3	Plastic	1 N/C + 1 N/O	3 m cable	44536-0300
CM-S3PC5	Plastic	1 N/C + 1 N/O	5 m cable	44536-0305
CM-S5PC5	Plastic	1 N/C + 1 N/O	5 m cable	44536-0505
CM-S5PC10	Plastic	1 N/C + 1 N/O	10 m cable	44536-0510
CM-S6PC5	Plastic	1 N/C + 1 N/O	5 m cable	44536-0605
CM-S6PC10	Plastic	1 N/C + 1 N/O	10 m cable	44536-0610
Universal Reed Style Switches (can be used with safety monitoring relays that accept 1N/C + 1N/O or 2NC switch contacts except the SR203, SR208, SR209) <i>CAUTION! Universal reed switches may be operated with a coded or non-coded actuator when using 2 NC contacts with a safety monitoring relay.</i>				
CM-S221PC5	Plastic	2 N/C + 1 N/O	5 m cable	44536-0221
CM-S521PC5	Plastic	2 N/C + 1 N/O	5 m cable	44536-0521
CM-S521PC10	Plastic	2 N/C + 1 N/O	10 m cable	44536-1521
CM-S621PC5	Plastic	2 N/C + 1 N/O	5 m cable	44536-0621
CM-S621PC10	Plastic	2 N/C + 1 N/O	10 m cable	44536-1621
CM-S321SC5	Stainless Steel	2 N/C + 1 N/O	5 m cable	44536-3221
CM-S321SCC5	Stainless Steel, backing plate	2 N/C + 1 N/O	connector + 5 m cable	44536-3229
CM-S321SCC	Stainless Steel, backing plate	2 N/C + 1 N/O	connector, no cable	44536-3220
CM-S421SC5	Stainless Steel, No backing plate	2 N/C + 1 N/O	5 m cable	44536-4221
CM-S421SCC5	Stainless Steel, No backing plate	2 N/C + 1 N/O	connector + 5 m cable	44536-4229
Recommended Safety Monitoring Relays for Universal Reed Style Switches				
CM-S4, CM-S30, G9SA series, G9SX-AD, G9SX-BC, SR series				
Spare Actuators/Accessories				
Replacement Actuator for CM-S1, Red ABS Plastic				44536-0710
Replacement Actuator for CM-S2, Red ABS Plastic				44536-0720
Replacement Actuator for CM-S3, Red ABS Plastic				44536-0730
Replacement Actuator for CM-S5, CM-S521 Red ABS Plastic				44536-0750
Replacement Actuator for CM-S6, CM-S621 Red ABS Plastic				44536-0760
Replacement Actuator for CM-S11, Red ABS Plastic				44536-0711
Replacement Actuator for CM-S31, Red ABS Plastic				44536-0731
Replacement Actuator for CM-S221, Red ABS Plastic				44536-0721
Replacement Actuator for CM-S321, Stainless Steel, backing plate				44536-0741
Replacement Actuator for CM-S421, Stainless Steel, No backing Plate				44536-0751
Mounting Bracket for CM-S3				44536-0800

G

 = Highlighted **Rapid Delivery** products are available for shipment today or within **FIVE** days.

 Universal Mounting Brackets can be used with this product. See page G247 for details.