

Installation Instructions for the Magnetoresistive Sensor ICs Standard Power Series: SM351RT, SM451R, SM353RT, SM453R

32304117
Issue B

Table 1. Electrical Specifications (3 V ≤ Vcc ≤ 24 V, -40 °C ≤ Ta ≤ 85 °C [-40 °F ≤ Ta ≤ 185 °F] unless otherwise specified.)

Characteristic	Condition	Min.	Typ.	Max.	Unit
Supply voltage (Vcc)	Vcc reference to ground	3	12	24	V
Supply current:	—	—	—	8	mA
off	Vcc = 5 V, T = 25 °C [77 °F]	—	2.5	3.5	
on	Vcc = 5 V, T = 25 °C [77 °F]	—	4	5	
Start-up time	Vcc > 3 V	—	—	10	μs
Output leakage current	Vcc = 24, off	—	—	10	μA
Output saturation voltage	load current = 20 mA	—	—	500	mV
Rise time	Vcc = 5 V, R = 2 kOhm, C = 20 pF	—	—	1.5	μs
Fall time	Vcc = 5 V, R = 2 kOhm, C = 20 pF	—	—	1.5	

Table 2. Magnetic Specifications (3 V < Vcc < 24 V, -40 °C < Ta < 85 °C [-40 °F < Ta < 185 °F].)

Characteristic	Min.	Typ.	Max.	Unit
SM351RT, SM451R:				Gauss
operate (positive)	3	7	11	
release (positive)	2	4.8	9	
hysteresis	—	2.2	—	
SM353RT, SM453R:				Gauss
operate (positive)	6	14	20	
release (positive)	3	9.3	18	
hysteresis	—	5.7	—	

NOTICE

The magnetic field strength (Gauss) required to cause the switch to change state (operate and release) will be as specified in the magnetic characteristics. To test the switch against the specified magnetic characteristics, the switch must be placed in a uniform magnetic field.

NOTICE

These magnetoresistive sensor ICs may have an initial output in either the ON or OFF state if powered up with an applied magnetic field in the differential zone (applied magnetic field >Brp and <Bop). Honeywell recommends allowing 10 μs for output voltage to stabilize after supply voltage has reached its final rated value.

Table 3. Absolute Maximum Ratings

Characteristic	Condition	Min.	Typ.	Max.	Unit
Operating temperature	ambient	-40 [-40]	—	85 [185]	°C [°F]
Soldering temperature:					°C [°F]
SM351RT, SM353RT	ambient applied for < 10 s	—	—	245 [473]	
SM451R, SM453R	ambient applied for < 3 s	—	—	260 [500]	
Supply voltage (Vs)	—	-26	—	26	V
Load current	output sinking (open collector)	—	—	40	μA

NOTICE

Absolute maximum ratings are the extreme limits that the device will withstand without damage to the device. However, the electrical and mechanical characteristics are not guaranteed as the maximum limits (above recommended operating conditions) are approached, nor will the device necessarily operate at absolute maximum ratings.



Magneto-resistive Sensor ICs

Standard Power Series: SM351RT, SM451R, SM353RT, SM453R

Issue B
32304117

Figure 1. Typical Magnetic Performance Over Temperature

SM351RT, SM451R

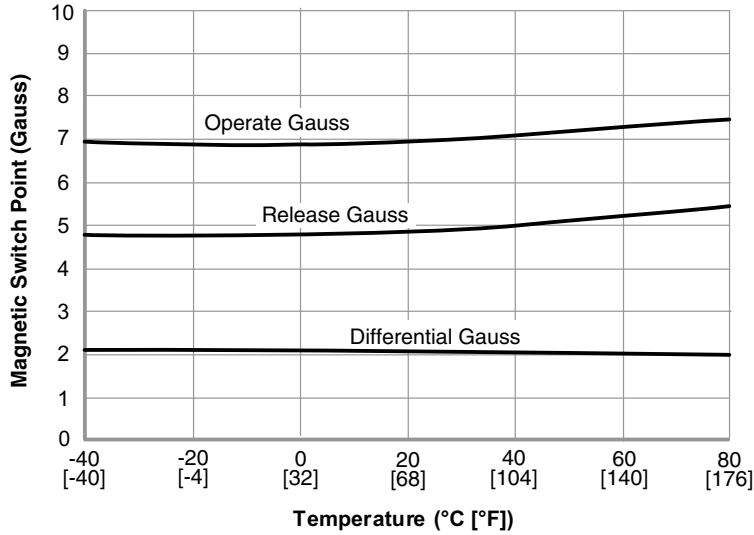

SM353RT, SM453R

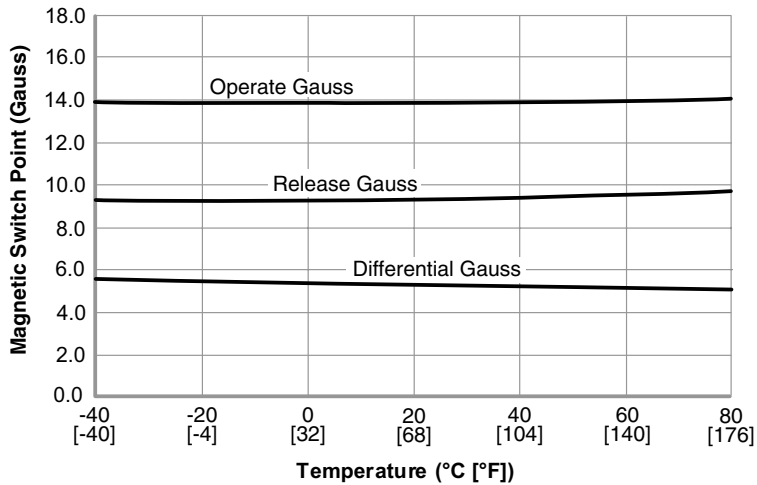
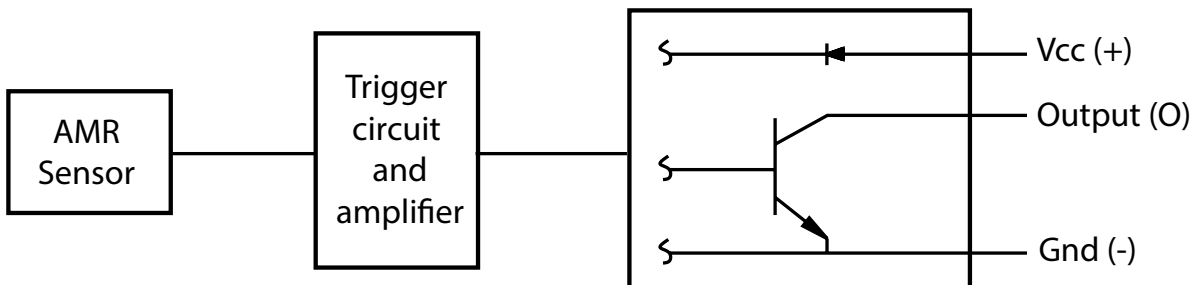

Figure 2. Block/Electrical Diagram



Magneto-resistive Sensor ICs

Standard Power Series: SM351RT, SM451R, SM353RT, SM453R

Issue B
32304117

Figure 3. Alignment of the Magnet to the SOT-23 Package (SM351RT, SM353RT) Omnipolar Magneto-resistive Sensor IC

Ideal alignment: The magnet is aligned in the same plane as the sensor IC.

The magnetic flux lines stay horizontal as the magnet approaches the sensor IC (see Figure 3.A).

Figure 3.A

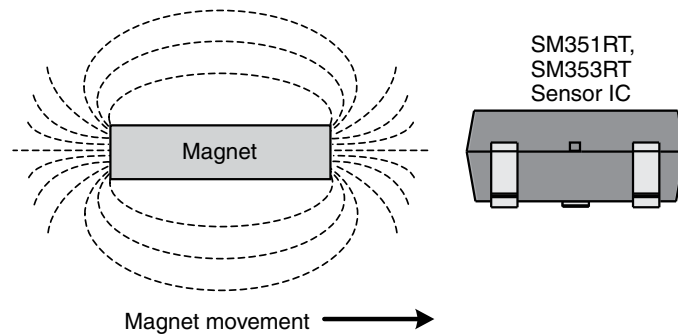

Offset alignment: The magnet is not aligned in the same plane as the sensor IC.

Parallel magnet approach to the sensor IC may cause dead zones.

Dead zones may occur when the majority of the magnet's magnetic flux lines become vertical as it approaches the sensor IC, turning the sensor IC ON, then OFF, then ON (see Figure 3.B).

Figure 3.B

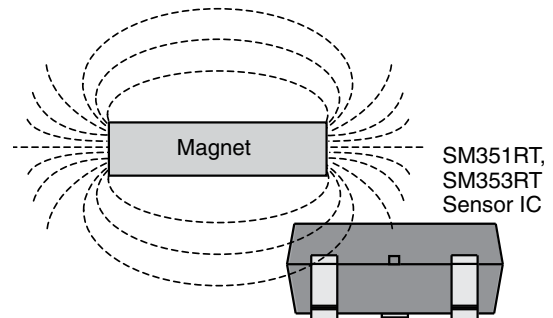

Perpendicular magnet approach to the sensor IC eliminates possible dead zones.

The sensor IC detects the approaching magnet's horizontal magnetic flux lines, turning the sensor IC to ON. The sensor IC stays ON as the magnet continues to approach. When the magnet is located directly over the sensor IC, all magnetic flux lines are now horizontal (see Figure 3.C). (Note: This alignment decreases the magnetic flux strength at the sensor IC.)

Figure 3.C

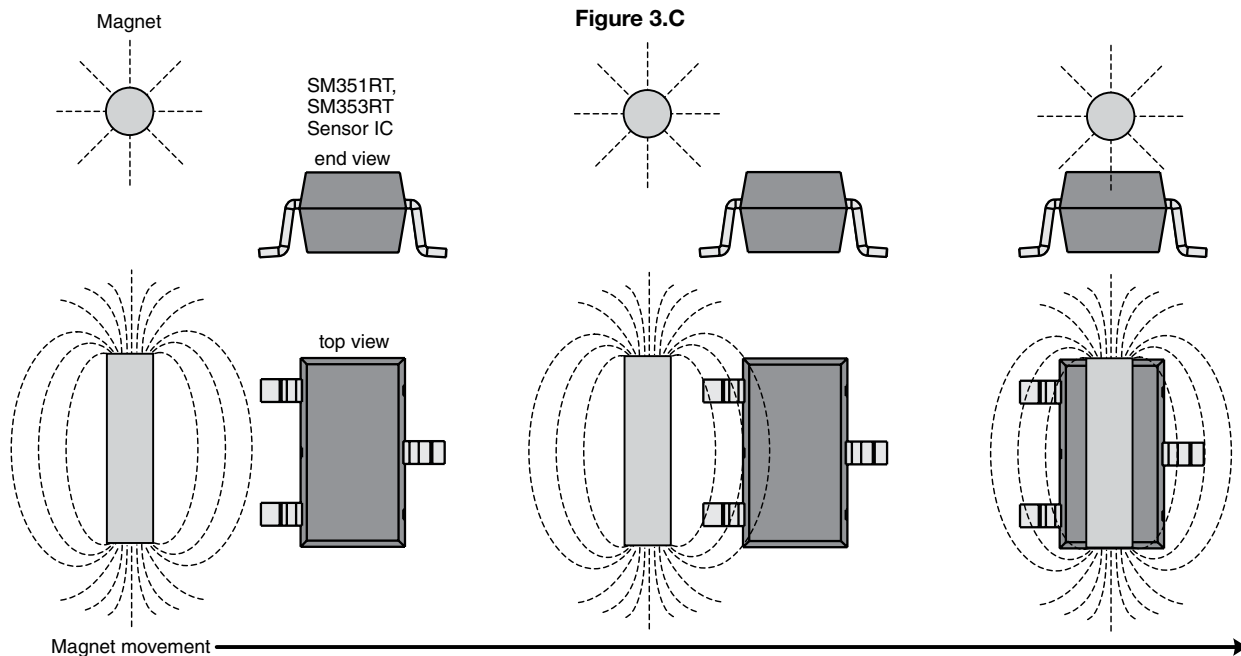

Magneto-resistive Sensor ICs

Standard Power Series: SM351RT, SM451R, SM353RT, SM453R

Issue B
32304117

Figure 4. Alignment of the Magnet to the TO-92-Style Package (SM451R, SM453R) Omnipolar Magneto-resistive Sensor IC

Ideal alignment: The magnet is aligned in the same plane as the sensor IC.

The magnetic flux lines stay horizontal as the magnet approaches the sensor IC (see Figure 4.A).

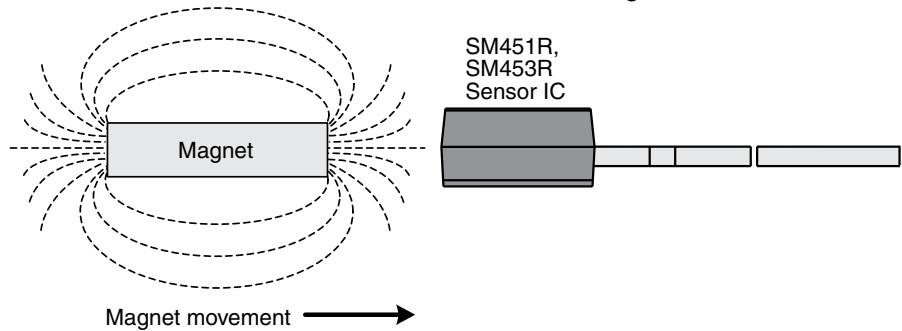

Figure 4.A

Offset alignment: The magnet is not aligned in the same plane as the sensor IC.

Parallel magnet approach to the sensor IC may cause dead zones.

Dead zones may occur when the majority of the magnet's magnetic flux lines become vertical as it approaches the sensor IC, turning the sensor IC ON, then OFF, then ON (see Figure 4.B).

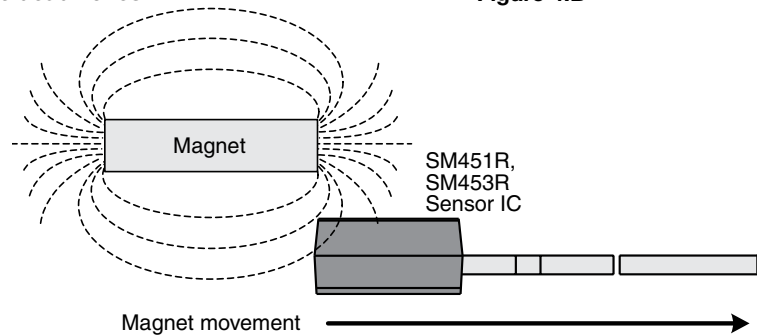

Figure 4.B

Perpendicular magnet approach to the sensor IC eliminates possible dead zones.

The sensor IC detects the approaching magnet's horizontal magnetic flux lines, turning the sensor IC to ON. The sensor IC stays ON as the magnet continues to approach. When the magnet is located directly over the sensor IC, all magnetic flux lines are now horizontal (see Figure 4.C). (Note: This alignment decreases the magnetic flux strength at the sensor IC.)

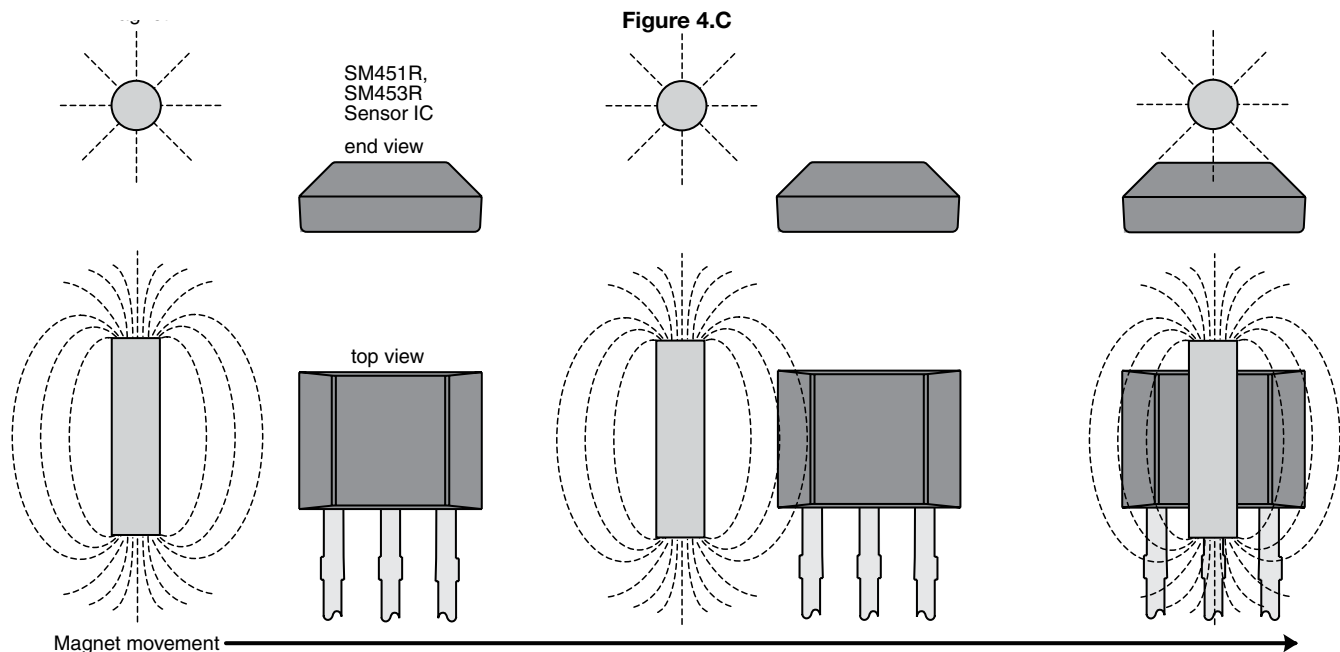

Figure 4.C

Magnetostrictive Sensor ICs

Standard Power Series: SM351RT, SM451R, SM353RT, SM453R

Issue B
32304117

Figure 5. SM351RT, SM353RT Sensor IC, Tape and Reel Mounting Dimensions (For reference only. mm/[in.])

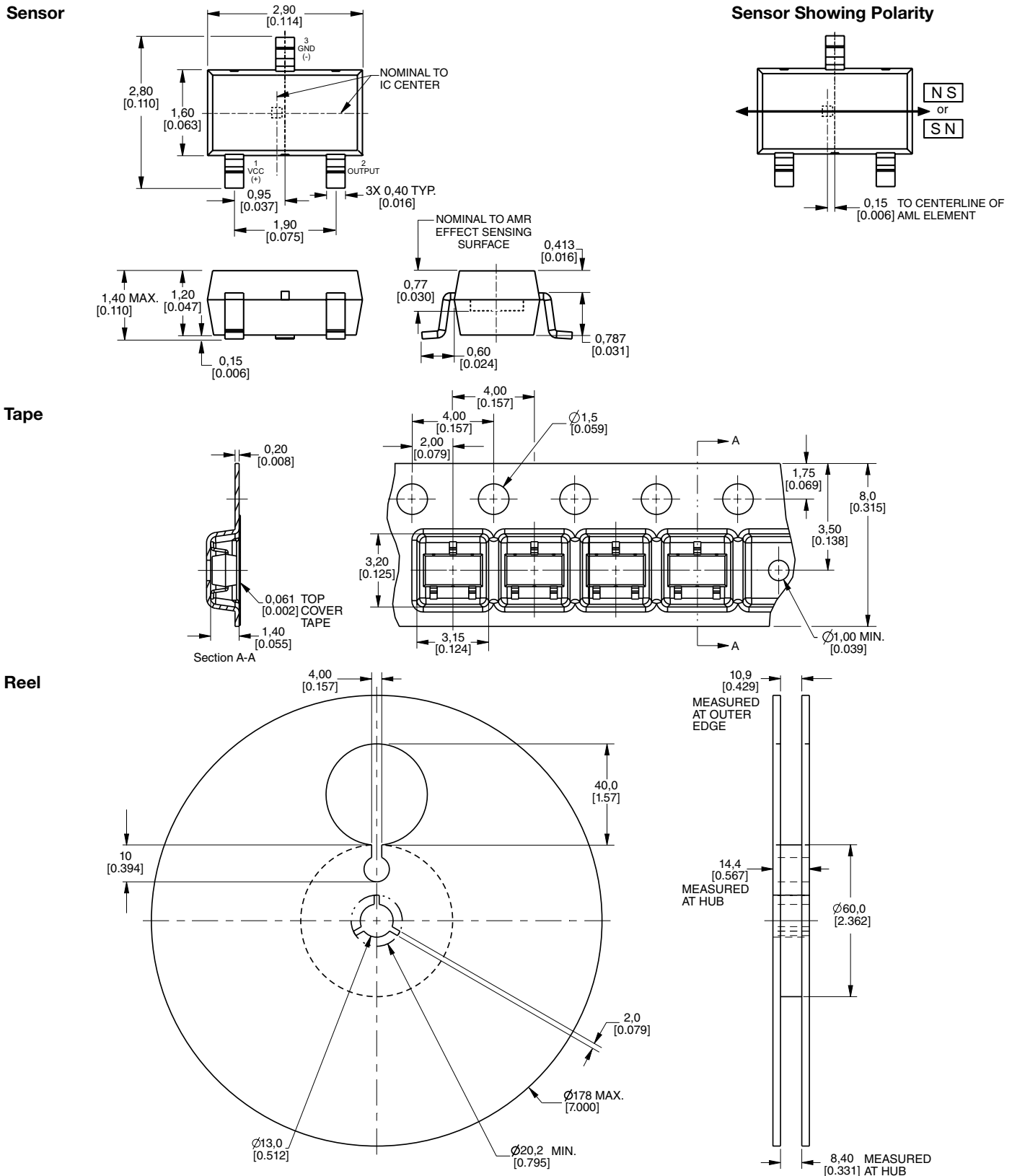

Magneto-resistive Sensor ICs

Standard Power Series: SM351RT, SM451R, SM353RT, SM453R

Issue B
32304117

Figure 6. SM451R and SM453R Sensor IC Mounting Dimensions (For reference only. mm/[in].)

Sensor

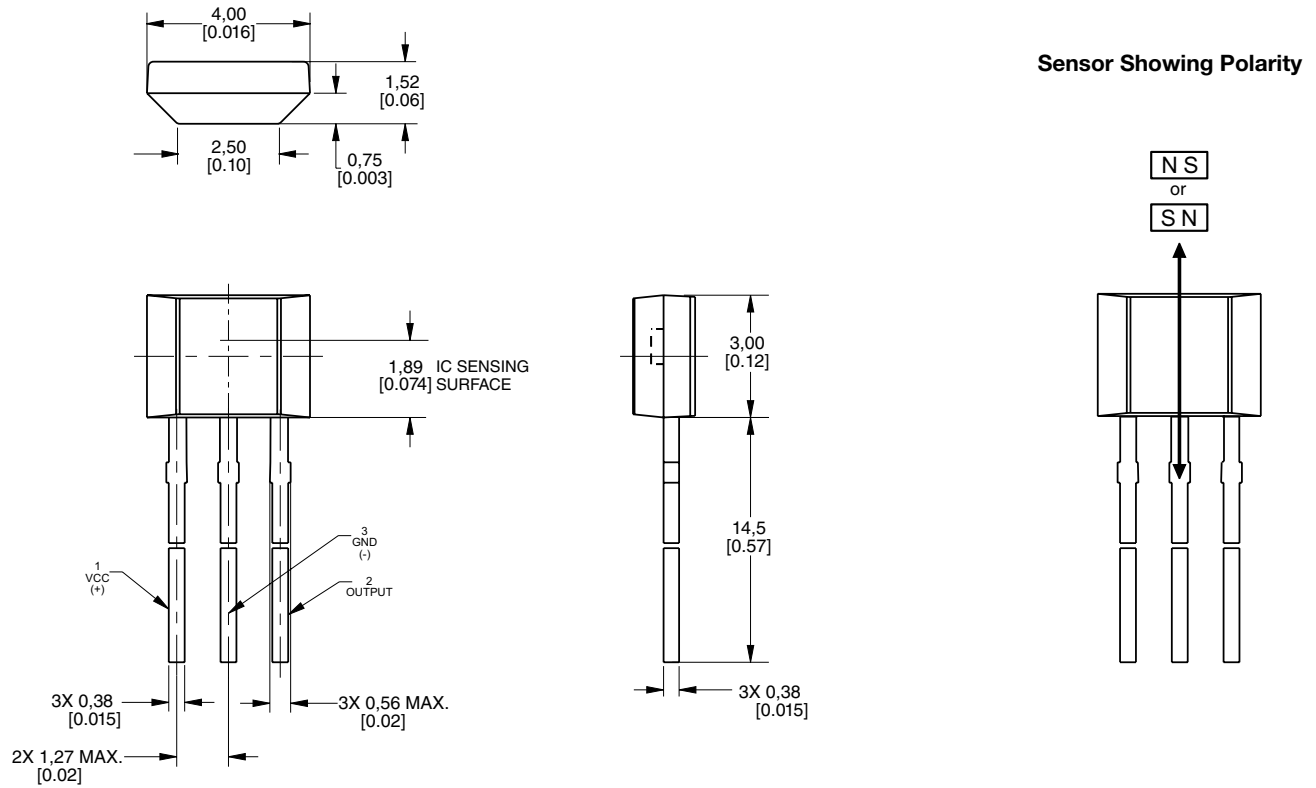

▲ WARNING

PERSONAL INJURY

DO NOT USE these products as safety or emergency stop devices or in any other application where failure of the product could result in personal injury.

Failure to comply with these instructions could result in death or serious injury.

WARRANTY/REMEDY

Honeywell warrants goods of its manufacture as being free of defective materials and faulty workmanship. Honeywell's standard product warranty applies unless agreed to otherwise by Honeywell in writing; please refer to your order acknowledgement or consult your local sales office for specific warranty details. If warranted goods are returned to Honeywell during the period of coverage, Honeywell will repair or replace, at its option, without charge those items it finds defective. **The foregoing is buyer's sole remedy and is in lieu of all other warranties, expressed or implied, including those of merchantability and fitness for a particular purpose. In no event shall Honeywell be liable for consequential, special, or indirect damages.**

While we provide application assistance personally, through our literature and the Honeywell web site, it is up to the customer to determine the suitability of the product in the application.

Specifications may change without notice. The information we supply is believed to be accurate and reliable as of this printing. However, we assume no responsibility for its use.

Honeywell serves its customers through a worldwide network of sales offices, representatives and distributors. For application assistance, current specifications, pricing or name of the nearest Authorized Distributor, contact your local sales office or:

E-mail: info.sc@honeywell.com

Internet: sensing.honeywell.com

Phone and Fax:

USA/Canada +1-800-537-6945

International +1-815-235-6847; +1-815-235-6545 Fax