

# Wireless-Mbus Modules

---

User guide version V2.3  
Software version V3.03 & V03.02 & V04.03

## **ADEUNIS RF**

283 rue Louis Néel - Parc Technologique Pré Roux  
38920 CROLLES - France  
Tel. : +33 (0)4 76 92 07 77 - Fax : +33 (0)4 76 04 80 87  
[www.adeunis-rf.com](http://www.adeunis-rf.com)      [arf@adeunis-rf.com](mailto:arf@adeunis-rf.com)



## Information

Document information	
<b>Title</b>	Wireless M-Bus module User guide
<b>Subtitle</b>	Version 2.2 - Software Version V3.03 & V03.02 & V04.03
<b>Document type</b>	Hardware integration and software management manual
<b>Document status</b>	Release for Wireless M-Bus software version V3.03 & V03.02 & V04.03

This document applies to the following products

Name	Reference	Firmware version
<b>WMBUS TRX 25mW</b>	ARF7751BB	V3.03
<b>WMBUS TRX 25mW AES/OMS</b>	ARF7751CA	V03.02
<b>WMBUS TRX 25mW AES/OMS + mode C</b>	ARF7751CB	V04.03

## Disclaimer

This document and the use of any information contained therein, is subject to the acceptance of the Adeunis RF terms and conditions. They can be downloaded from [www.adeunis-rf.com](http://www.adeunis-rf.com).

Adeunis RF makes no warranties based on the accuracy or completeness of the contents of this document and reserves the right to make changes to specifications and product descriptions at any time without notice.

Adeunis RF reserves all rights to this document and the information contained herein. Reproduction, use or disclosure to third parties without express permission is strictly prohibited. Copyright © 2012, Adeunis RF.

Adeunis RF is a registered trademark in the EU and other countries.

## Technical Support

### Website

Our website contains many useful information : modules and stand alone products information, user guides, configuration software and technical documents which can be accessed 24 hours a day.

### Email

If you have technical problems or cannot find the required information in the provided documents, contact our Technical Support by email. Use our dedicated email address ([arf@adeunis-rf.com](mailto:arf@adeunis-rf.com)) rather than any personal email address of our staff. This makes sure that your request is processed as soon as possible.

### Helpful Information when Contacting Technical Support

When contacting Technical Support please have the following information ready:

- Product type (e.g. Wireless M-Bus),
- Firmware version (e.g. V3.03)
- Clear description of your question or the problem
- A short description of the application
- Your complete contact details

## Declaration of conformity

We ADEUNIS RF,  
283 rue LOUIS NEEL, 38920 CROLLES, France

declare under our own responsibility that the products

Name Wireless M-Bus module  
Reference(s) ARF7751BB, ARF7751CA, ARF7751CB

to which this declaration refers conform with the relevant standards or other standardising documents

- EN 300 220-2 (v2.3.1) (2010-02)
- EN 60950-1 (2001) + A11 (2004)
- EN 301 489-1 (v1.8.1) (2008-04)
- EN 301 489-3 (v1.4.1) (2002-08)
- EN 62311 (2008)

According to the RTTE Directive 99/5/EC

### Notes:

- Conformity has been evaluated according to the procedure described in Annex III of the RTTE directive
- Receiver class (if applicable): 3

Crolles, 18 November 2010

Hervé Vincent, CEO



## Table of contents

Information	2
Disclaimer	2
Technical Support	2
Declaration of conformity	3
<b>INTRODUCTION</b>	<b>6</b>
Environmental recommendations	6
Warnings	6
Disposal of waste by users in private households within the European Union	7
<b>EINLEITUNG</b>	<b>7</b>
Hinweise zum Umweltschutz	7
Warnhinweise	8
Entsorgung der Abfälle von Betreibern in Privathaushalten innerhalb der Europäischen Union	8
<b>Modules Functionnalities</b>	<b>8</b>
<b>1. Modules overview</b>	<b>9</b>
1.1. Adeunis module concept	9
1.2. Module functionality	9
1.3. Wireless M-Bus (WMBUS)	9
1.4. Technical specifications	9
<b>2. Main characteristics</b>	<b>10</b>
2.1. Form factor and footprint	10
2.2. Pins description	10
2.2.1 Pinout of the module	10
2.2.2 Pin configuration	11
2.3. Recommended design	12
<b>3. Electrical &amp; Radio characteristics</b>	<b>12</b>
3.1. Absolute Maximum Specification	12
3.2. Global Electrical Characteristics	12
3.3. IOs Electrical Characteristics	12
3.4. Typical radio characteristics	13
3.5. Antenna	13
<b>4. Communication modes</b>	<b>14</b>
4.1. Mode S (default mode)	14
4.2. Mode T (Fast transmit)	14
4.3. Mode C (Compact mode, best energy budget) (from module ARF7751CB)	15
4.4. Mode R (best range)	15

<b>5.</b>	<b>Modem state machine</b>	<b>16</b>
5.1.	Modes switching process	16
5.2.	Command Mode	17
5.3.	Communication mode	19
5.3.1	One way mode	20
5.3.1.01	Quick setup of meter:	20
5.3.1.02	Quick setup of other module:	20
5.3.1.03	Data transfer with T1 S1 R «one way» mode	20
5.3.2	Two way mode	21
5.3.2.01	T2 use cases overview	21
5.3.2.02	R2 Use cases overview	22
5.3.2.03	S2 Use cases overview	22
5.4.	Packet format	24
5.5.	Tx frame format (Host to Module)	24
5.6.	Tx frame extended format (Host to Module)	24
5.7.	Rx frame format (Module to Host)	24
<b>6.</b>	<b>Other functionalities</b>	<b>25</b>
6.1.	Low Power Mode	25
6.2.	Set-up of preamble length and periodic wakeup time	25
6.3.	OMS Encryption (Module ARF7751CA/CB)	26
6.4.	Cyclic synchronous retransmission (OMS support)	26
6.5.	Specific ARF-AES128 encryption (Module ARF7751CA/CB)	27
6.5.1	Typical ARF-AES128 use cases	27
6.6.	Specific frame output format	28
<b>7.</b>	<b>Version history</b>	<b>28</b>

## INTRODUCTION

All rights to this manual are the exclusive property of ADEUNIS RF. All rights reserved. Copying this manual (without written permission from the owner) via printing, copying, recording or by any other means, translating this manual (in full or partially) into any other language, including all programming languages, using any electrical, mechanical, magnetic or optical devices, manually or any by other methods, is prohibited.

ADEUNIS RF reserves the right to change the technical specifications or functions of its products, or to cease manufacturing any of its products, or to cease technical support for one of its products without notice in writing and urges its customers to make sure that the information they have is valid.

ADEUNIS RF configuration software and programs are available free of charge in a non-modifiable version. ADEUNIS RF can make no guarantees, including guarantees concerning suitability and applicability for a certain type of application. Under no circumstances can the manufacturer, or the distributor of an ADEUNIS RF program, be held liable for any damage caused by the use of the aforesaid program. Program names, as well as all copyright relating to programs, are the exclusive property of ADEUNIS RF. Any transfer, granting of licences to a third party, leasing, hire, transport, copying, editing, translation, modification into another programming language or reverse engineering are prohibited without ADEUNIS RF's prior written authorisation and consent.

ADEUNIS RF  
283, rue Louis Néel  
38920 Crolles  
France

Telephone +33 (0)4 76 92 07 77  
Fax +33 (0)4 76 08 97 46

## Environmental recommendations

All superfluous packaging materials have been eliminated. We have done everything possible to make it easy to separate the packaging into three types of materials: cardboard (box), expanded polystyrene (filler material) and polyethylene (packets, foam protective sheets). Your device is composed of materials that can be recycled and reused if it is dismantled by a specialist company. Please observe local regulations concerning the manner in which waste packaging material, used batteries and your obsolete equipment are disposed of.

## Warnings

Valid for Narrow Band modules with the following references: ARF7751  
Read the instructions in the manual.



The safety of this product is only guaranteed when it is used in accordance with its purpose.  
Maintenance should only be carried out by qualified persons.



Please note, do not install the equipment close to a heat source or in damp conditions.



Please note: for your own safety, you must ensure that the equipment is switched off before carrying out any work on it.



Please note: For your safety, the power supply circuit must be SELV (Safety Extra Low Voltage) and must be a limited power sources.

## Recommendations regarding use

- Before using the system, check that the power supply voltage shown in the user manual corresponds to your supply. If it doesn't, please consult your supplier.
- Place the device against a flat, firm and stable surface.
- The device must be installed in a location that is sufficiently ventilated so that there is no risk of internal heating and it must not be covered with objects such as newspapers, cloths, curtains, etc.
- The device's aerial must be free and at least 10 cm away from any conducting material.
- The device must never be exposed to heat sources such as heating equipment.
- Do not place the device close to objects with naked flames such as lit candles, blowtorches, etc.
- The device must not be exposed to aggressive chemical agents or solvents likely to damage the plastic or corrode the metal parts.
- Install your device close to its DC power supply.

## Disposal of waste by users in private households within the European Union



This symbol on the product or on its packaging indicates that this product must not be disposed off with your other household waste. Instead, it is your responsibility to dispose of your waste by taking it to a collection point designated for the recycling of electrical and electronic appliances. Separate collection and recycling of your waste at the time of disposal will contribute to conserving natural resources and guarantee recycling that respects the environment and human health. For further information concerning your nearest recycling centre, please contact your nearest local authority/town hall offices, your household waste collection company or the shop where you bought the product.

## EINLEITUNG

Alle Rechte an diesem Handbuch sind das alleinige Eigentum der ADEUNIS RF. Alle Rechte sind vorbehalten. Jede (ohne die schriftliche Genehmigung des Eigentümers erfolgende) Wiedergabe dieses Handbuches durch Druck, Kopie, Aufzeichnung oder jedwedes andere Mittel sowie die (vollständige oder teilweise) Übersetzung in jede andere Sprache einschließlich aller Programmiersprachen durch Verwendung welcher elektrischer, mechanischer, magnetischer, optischer, manueller Vorrichtungen oder anderen Methoden auch immer, sind verboten.

Die ADEUNIS RF behält sich das Recht vor, ohne irgendeine schriftliche Mitteilung die technischen Spezifikationen oder die Funktionen ihrer Produkte zu verändern, bzw. die Herstellung eines ihrer Produkte einzustellen oder den technischen Support für eines ihrer Produkte auszusetzen und bittet ihre Kunden inständig sich zu vergewissern, dass die ihnen zur Verfügung stehenden Informationen zutreffend sind.

Die Konfigurations- und Programmsoftware der ADEUNIS RF steht kostenlos in einer Version zur Verfügung, die nicht verändert werden kann. Die ADEUNIS RF kann keinerlei Garantie und auch keine Garantie zur Eignung und Anwendbarkeit für eine Applikation bestimmten Typs gewähren. Der Hersteller oder der Verkäufer eines Programms der ADEUNIS RF kann in keinem Fall für irgendwelche Schäden haftbar gemacht werden, die durch die Anwendung des besagten Programms gegebenenfalls verursacht werden könnten. Die Bezeichnungen der Programme sowie alle Urheberrechte zu den Programmen sind das alleinige Eigentum der ADEUNIS RF. Jede Übertragung, Gewährung von Lizenzen an einen Dritten, Leasingvergabe, Vermietung, Übereignung, Kopie, Übersetzung, Modifizierung in eine andere Programmiersprache oder durch ein Reverse Engineering ist ohne die schriftliche Genehmigung und ohne das Einverständnis der ADEUNIS RF verboten.

ADEUNIS RF  
 283, rue Louis Néel  
 38920 Crolles  
 France

Tel +33 (0)4 76 92 07 77  
 Fax +33 (0)4 76 08 97 46

## Hinweise zum Umweltschutz

Alle überflüssigen Verpackungsmaterialien wurden vermieden. Wir haben auch alles getan, was uns möglich ist, damit die Verpackung ohne Weiteres in drei Typen von Werkstoffen getrennt werden kann : Karton (die Schachtel), geschäumtes Polystyrol (Dämmmaterial) und Polyäthylen (Beutel, Schaumfolie zum Schutz). Ihr Gerät besteht aus Werkstoffen, die recycelt und weiterverwendet werden können, wenn es von einem darauf spezialisierten Unternehmen demontiert wird. Beachten Sie bitte die jeweils geltenden örtlichen Vorschriften zur Entsorgung der Verpackungsmaterialien, der verbrauchten Batterien und Ihres ausgemusterten Gerätes.

## Warnhinweise

Gültig für die Relaisempfänger mit den Artikelnummern : ARF7751



Lesen Sie die Anleitungen dieses Handbuches.



Die durch dieses Produkt gewährte Sicherheit kann nur bei einer Anwendung entsprechend dem vorgesehenen Einsatzzweck gewährleistet werden.



Achtung ! Zu Ihrer eigenen Sicherheit ist es unerlässlich, das Gerät vor jedem technischen Eingriff spannungsfrei zu schalten.



Achtung ! Zu Ihrer eigenen Sicherheit die Stromversorgung Schaltung muss SELV (Safety Extra Low Voltage) sein und muss der begrenzten Stromquellen sein.

Empfehlungen für den Einsatz

- Vor dem Einsatz des Systems müssen Sie überprüfen, dass die in der Bedienungsanleitung angegebene Anschlussspannung den Werten Ihrer Stromversorgung entspricht. Anderenfalls wenden Sie sich bitte an Ihren Lieferanten.
- Stellen Sie das Gerät auf einer ebenen, festen und stabilen Fläche auf.
- Um jede Gefahr einer inneren Erwärmung des Gerätes zu vermeiden, ist dieses an einem gut belüfteten Ort aufzustellen und darauf zu achten, dass keine Gegenstände wie Zeitschriften, Matten, Vorhänge u. a. darauf abgelegt werden.
- Die Antenne des Gerätes muss frei liegen und von jeglichen leitenden Werkstoffen mindestens 10 cm entfernt sein.
- Das Gerät darf niemals der Einwirkung von Wärmequellen oder Heizgeräten ausgesetzt sein.
- Das Gerät darf sich niemals in der Nähe von Gegenständen mit offener Flamme befinden, wie brennenden Kerzen, Schweißbrennern usw.
- Das Gerät darf niemals der Einwirkung von aggressiven Chemikalien oder Lösemittel ausgesetzt werden, die geeignet sein könnten, den Kunststoff zu beschädigen oder die Metallteile zu korrodieren.
- Stellen Sie Ihr Gerät in der Nähe der Quelle seiner Spannungsversorgung DC auf.

## Entsorgung der Abfälle von Betreibern in Privathaushalten innerhalb der Europäischen Union



Dieses Symbol auf dem Produkt oder auf seiner Verpackung weist darauf hin, dass dieses Produkt nicht gemeinsam mit Ihrem anderen Haushaltsmüll entsorgt werden darf. Stattdessen haben Sie dafür Sorge zu tragen, Ihre Abfälle bei einer Erfassungsstelle zu entsorgen, die auf das Recycling elektrischer und elektronischer Geräte spezialisiert ist. Die gesonderte Erfassung und das Recycling ihrer Abfälle bei der Entsorgung tragen dazu bei, die natürlichen Ressourcen zu bewahren und ein Recycling zu gewährleisten, das dem Schutz der Umwelt und der menschlichen Gesundheit dient. Für weitere Informationen zu der Ihrer Wohnung am nächsten gelegene Recyclingstelle wenden Sie sich bitte an die örtliche Gemeindeverwaltung, an die zuständige Dienststelle für die Müllabfuhr oder an das Geschäft, in dem sie das Gerät gekauft haben

## Modules Functionnalities

- Embedded
- Not embedded

Function	ARF7751BB	ARF7751CA	ARF7751CB
T1 / T2	●	●	●
R1 / R2	●	●	●
S1 / S2	●	●	●
C1	○	○	●
Low Power Mode	●	●	●
Synchronous cyclic Transmission	○	●	●
OMS mode 5 compliance	○	●	●
AES 128 encryption	○	●	●

## 1. Modules overview

### 1.1. Adeunis module concept

The idea behind Adeunis module concept is to provide the user with a module which is ready for sending and receiving data over a radio link thus enabling the user to focus on the development of his/her application. The aim is to relieve the user from having to deal with the complex radio management.

Adeunis Wireless-MBus comes in one version:

- “Ready To Use” version

Adeunis can also customize its catalogue products on customer specifications, which allows us to provide :

- “Customisable” versions

Both versions use the same hardware basis. The difference lies in the firmware which is running in the module. However, from a user standpoint, all versions of the firmware provide an abstraction layer in charge of the radio operating management. This manual describes the «Ready to use» version

### 1.2. Module functionality

“Ready To Use” versions are intended for user willing to embed a radio functionality onto their already existing electronic design.

In the “Ready To Use” versions the modules operates in a standalone way and behaves like a

Serial interface <-> RF gateway. So in this case, the user has to interface the module with a host processor where the application code will be running.

The diagram above represents the way Adeunis Wireless M-Bus works: on the transmitter side the module will send data coming from the serial link over the RF link and on the receiver side it will pass the data coming from the RF link onto the serial link.

The communication is half-duplex. By default, the modules provided by Adeunis-RF are in RTU mode. So they are directly usable without any extra configuration, except the Wireless M-Bus modes.

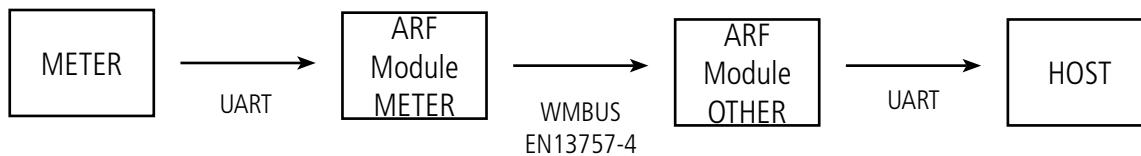

«Ready to use» offers to different modes :

- Command mode (default mode) used to set-up the module
- Communication mode, used to exchange data using the WMBUS format

### 1.3. Wireless M-Bus (WMBUS)

Wireless M-Bus is the open standard for wireless AMR (Automatic Meter Reading), to optimize automatic remote reading and control of meters (smart metering).

This document describes the implementation of our Wireless M-Bus module, for more details please refer to EN13757-4:2005 standard.

This standard uses the unlicensed 868 MHz frequency band with operating on 12 transmission channels with a throughput between 4.8 and 100kbps. All devices should comply with EN300-220 standard.

### 1.4. Technical specifications

Technical specifications	
Communication	Wireless M-Bus protocol all modes supported S1, S1-m, S2, T1, T2, R2 ,S2, T2, C1 (frame format A and B)
Module configuration	Through AT commands
Radio data rate	4.8kbps (mode R), 32 kbps (mode S) and 100 kbps (mode T, C)
UART data rate	115.2 kbauds
UART TTL ports	TXD - RXD - RTS - CTS
Frequency channel	10 (mode R) and 1 (mode S, C and T)

Technical specifications	
Programmable RF output power	Up to 25 mW (14 dBm)
Sensitivity	T mode: down to -110 dBm @ BER10 <sup>-3</sup> (Data rate 100kbps) S mode: down to -112 dBm @ BER10 <sup>-3</sup> (Data rate 32kbps) R mode: down to -117 dBm @ BER10 <sup>-3</sup> (Data rate 4.8kbps)
Operating range (open space)	External antenna: up to 1000 m
Operating voltage	2v to 3,6v (3,3v nominal)
Tx / Rx / Stanby / Sleep consumption	max 35mA / max 22mA / < 0.6µA / < 0.2µA
Operating temperature	-40°C / +85°C
Dimensions	26 x 16 x 2 mm
Standard compliance	EN 300-220, EN 301-489, EN 60950, EN 13757-4:2005, AES/OMS mode 5

## 2. Main characteristics

### 2.1. Form factor and footprint

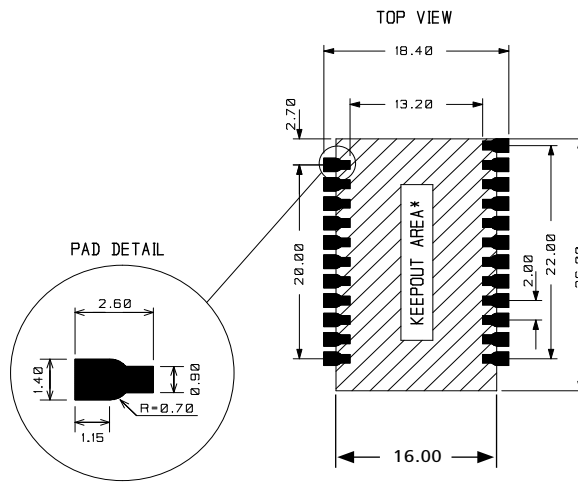

Please note : dxf & gerber files can be provided on demand.

### 2.2. Pins description

#### 2.2.1 Pinout of the module

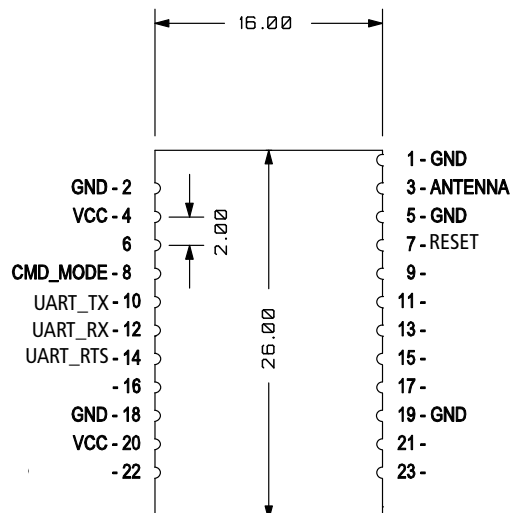

## 2.2.2 Pin configuration

Pin module	Pin name	I/O (1)	Description
1	GND		Ground (2)
2	GND		Ground (2)
3	ANTENNA		<b>RF output</b> Must be adapted with 50 ohms matching
4	VCC		<b>Supply voltage (2)</b>
5	GND		Ground (2)
6			(3)
7	/RESET	I	Low pulse to reset the module. May be left unconnected
8	CMD_MODE	I Internal pull-up	Command mode Should be connected to the host controller, may be left unconnected if command mode not used. Apply a low level to enter command mode
9			(3)
10	UART_TX	O	<b>Data output</b> Must be connected to the host controller
11			(3)
12	UART_RX	I Internal pull-up	<b>Data input</b> Must be connected to the host controller.
13			(3)
14	UART_RTS	O	<b>UART flow control</b> Must be connected to the host controller if hardware flow control is used, must be left unconnected if not used
15			(3)
16			(3)
17			(3)
18	GND		Ground (2)
19	GND		Ground (2)
20	VCC		<b>Supply voltage (2)</b>
21			(3)
22			(3)
23			(3)

- (1) Described from the module point of view (I : Is an input of the module, O is an output of the module) - The internal resistance is between 30Ko and 60Ko, typical 45Ko
- (2) All GND and VCC pins must be connected
- (3) Must be left unconnected

### 2.3. Recommended design

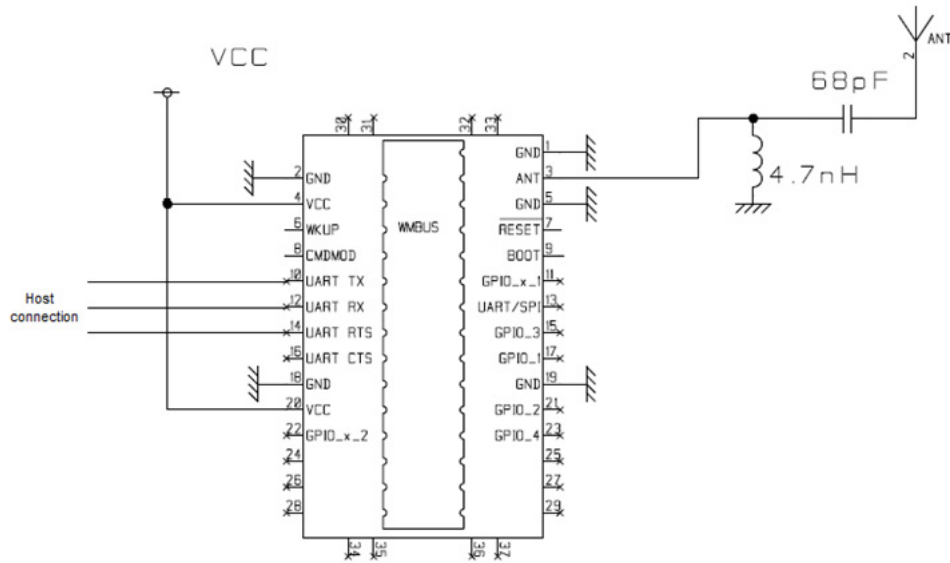

## 3. Electrical & Radio characteristics

The table below summarizes all the different electrical input/output generic characteristics of the modules

### 3.1. Absolute Maximum Specification

Parameter	Conditions	Min	Typ	Max	Units
Voltage on any GPIOs Pin	Vcc > 2.2 V	-0.3		Vcc+0.3	V
	Vcc < 2.2	-0.3		Vcc+0.3	V
Vcc	WMBUS	-0.3		3.6	V
RF input Power				10	dBm
Storage Temperature Range		-55		+125	°C

Stresses above those listed under “Absolute Maximum Ratings” may cause permanent damage to the module.

### 3.2. Global Electrical Characteristics

Parameter	Conditions	Min	Typ	Max	Units
Vcc	WMBUS	2V	2.4	3.6	V
Specified Operating Temperature Range		-30		70	°C

### 3.3. IOs Electrical Characteristics

Parameter	Conditions	Min	Typ	Max	Units
Input High Voltage	VCC = 2.0 to 3.6 V	VCC - 0.6			V
Input Low Voltage	VCC = 2.0 to 3.6 V			0,6	V
Output High Voltage	IOH = -1 mA	Vcc - 0.7			V
Output Low Voltage	IOL = 1.4 mA			0.6	V
Input Leakage Current	Weak Pullup On, VIN = 0 V, Vcc = 1.8V		4		µA

Parameter	Conditions	Min	Typ	Max	Units
	Weak Pullup On, Vin = 0 V, Vcc = 3.6 V		20	30	μA
Vcc Ramp Time for Power On	From 0V to 0,9Vmin			3	ms
Minimum RST Low Time to Generate a System Reset		15			μS
Reset Time Delay	Delay between release of any reset source and code execution		10		μS
Sleep Mode Wake-up Time		10	26		μS
CMD_MODE Time			500		μS
Power ON reset time		16	20		ms
Rise Time	0.1 x VCC to 0.9 x VCC, CL= 5 pF			8	ns
Fall Time	0.9 x VCC to 0.1 x VCC, CL= 5 pF			8	ns
Input Capacitance				1	pF
	0V < Vin < Vcc				
Weak Pull up activated	5			25	μA
Internal Weak Pull up resistor			220		KOhms

### 3.4. Typical radio characteristics

Sensitivity PER <20%

Voltage (V)	Temperature (°C)	Mode	Channel	Nominal Frequency (MHz)	Sensitivity (dBm)
3	25	R	10	868.27	-119
		S	x	868.3	-113
		T, C	x	868.95	-110

Sensitivity PER <1%

Voltage (V)	Temperature (°C)	Mode	Channel	Nominal Frequency (MHz)	Sensitivity (dBm)
3	25	R	10	868.27	-117
		S	x	868.3	-110
		T, C	x	868.95	-107

### 3.5. Antenna

The footprint of the inductor and capacitor are useful to ensure good impedance matching between antenna and Adeunis modules. The values will depend on the selected RF frequency and characteristics of the antenna.

The SMA connector can be bent or straight depending on the selected antenna but is not essential. We could very well consider 8.6 cm welded wire antennas directly on the PCB either horizontally or vertically. However and wherever possible, it is interesting to keep the footprint of SMAs to facilitate the development for the degrees of freedom offered from an application point of view (offset antenna, etc ...). We would offer the antennas associated with these connectors.

For a quick set-up, we recommend not to get the inductor, to install the capacitor to 27 pF (or replace it by a short circuit or a 0 ohm resistor) and solder a 8.6 cm length wire behind the capacitor.

ADEUNIS RF will assist you in your choice of antennas so as to optimize the performance of your products. Feel free to contact us for more information.

## 4. Communication modes

Devices which implement Wireless M-Bus stack are classified as either Meters, Others or Repeater devices, those three roles are define as such:

- Meters are mainly use for devices requiring sending information to a master, considered as slave or Tx devices.
- Others or Concentrator are use for devices collecting data from meters, also considered as master or Rx devices. It happens that the concentrator sends information to the meter, to confirm it is ready to receive data, or to acknowledge data reception.
- Repeater are transponder devices, to allow data transfer from a meter to a concentrator.

The protocol stack defines three operating modes to exchange data between meters and Others:

**Mode S:** "Default Stationary" mode (a number of times per day )

**Mode T:** "Fast Transmit" mode (short data burst every few seconds)

**Mode R:** "Best RF range" mode, 10 frequency channels

**Mode C:** "Compact Mode". This mode is similar to mode T but it allows more data transmission within the same energy budget and with the same duty cycle.

### 4.1. Mode S (default mode)

This mode includes 3 sub modes: S1, S1-m and S2

Sub mode S1 is a unidirectional communication link. The meter sends RF data as soon as it received them on its UART input, it doesn't care if the concentrator is ready or not. It returns in standby mode after transmission. This mode uses long header.

Sub modes S1-m is similar to S1, but with its short header, the transmit period has a duty cycle limitation of 0,02 % per hour. It requires a receiver continuously enabled.

Sub modes S2 is a bidirectional communication link. Before sending any data, the meter checks if it receives a wake up frame, which can be seen like a "OK" to send frame. After, it returns in sleep or standby mode.

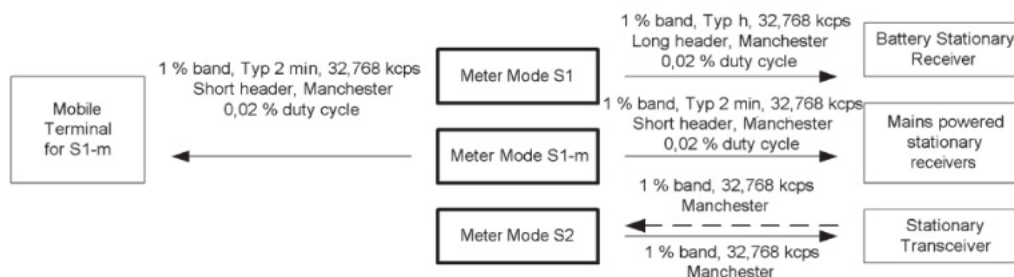

### 4.2. Mode T (Fast transmit)

This mode includes 2 sub modes: T1 and T2

Sub mode T1 is a unidirectional communication link. The meter sends RF data as soon as it received them on its UART input, it doesn't care if the concentrator is ready or not. It returns in sleep or standby mode after transmission.

Sub mode T2 is a bidirectional communication link, meter sends its data on a regular basis, but it stays awake for a short period to receive a potential Acknowledge for the concentrator. The Acknowledge frame is use to lock on, if further bi-directional communication may follow.

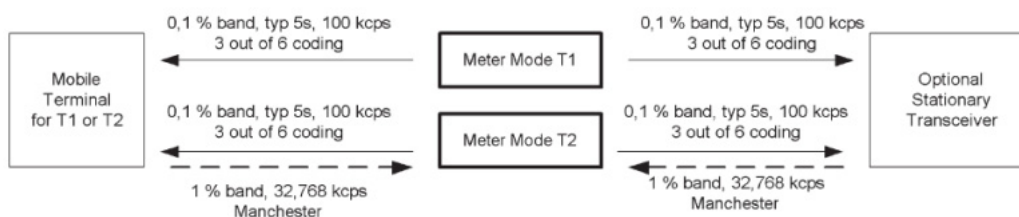

### 4.3. Mode C (Compact mode, best energy budget) (module ARF7751CB)

C mode is part of the standard EN13757-4 release in 2013 as well as the existing modes such as modes R, S or T. This mode is mainly used by heat meters and water meters.

It saves up to 50% energy compared to other modes which ensures a high degree of autonomy (battery life).

C mode is distinguished from other modes by removing unnecessary and / or redundant data (reduced CRC and NRZ encoding).

The module includes submode C1, with frame format A and B. In order to get the best economy budget, Adeunis RF suggests to use Frame Format B. For more detailed information, please refer to EN13757-4 V2013.

Sub mode C1 is a unidirectional communication link. The meter sends RF data as soon as it received them on its UART input, it doesn't care if the concentrator is ready or not. It returns in sleep or standby mode after transmission.

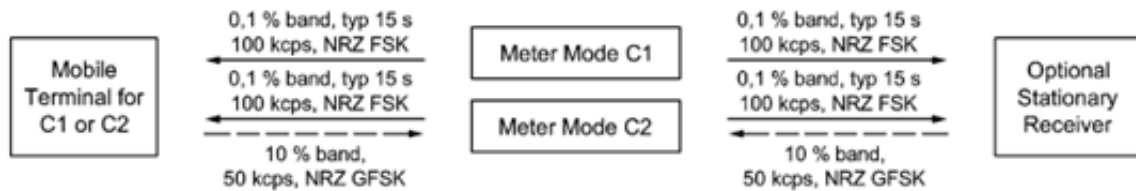

### 4.4. Mode R (best range)

In this mode, the meter sends data only if it receives a wake up frame ("OK to send"), in that case a bidirectional link is open, otherwise the device returns in sleep or standby mode. In this mode, 10 frequency channels are available.

A one way «R1» mode is also available on our module.

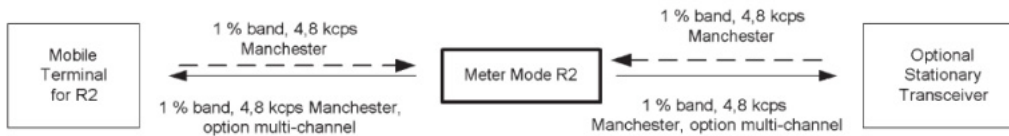

Please find below the list of available channels in Mode R (0 to 9)

Channel number	Frequency
C0	868.030 Mhz
C1	868.090 Mhz
C2	868.150 Mhz
C3	868.210 Mhz
C4	868.270 Mhz
C5	868.330 Mhz
C6	868.390 Mhz
C7	868.450 Mhz
C8	868.510 Mhz
C9	868.570 Mhz

## 5. Modem state machine

At startup, the module is checking the CMD\_MODE pin and the Boot selection parameter to access either the Command mode or the communication mode. Default setting of the «Ready-to-use» module is : serial rate : 115.2kbps  
 The following figure highlights how to use or «Ready-to-use» module :

### First step

- go to command mode

### Second step

- setup you parameter (meter/other, mode R/S/T)
- Option : save your configuration
- Leave command mode

### Third step

- Operation mode. Exchange (receive and/or transmit) frames

### 5.1. Modes switching process

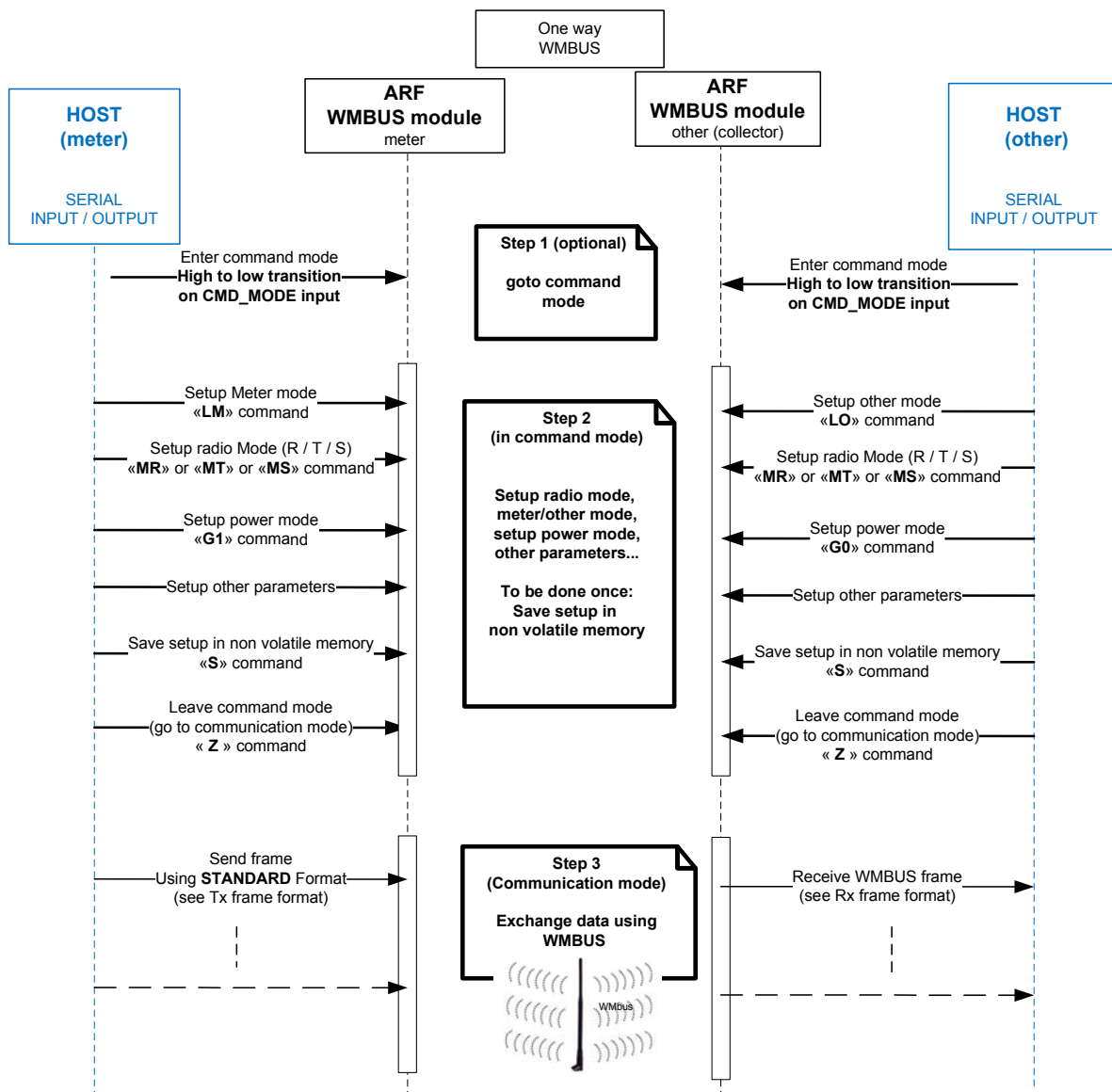

Entering the command mode can be achieved in different ways as illustrated in the following figure.

**Warning !** : for module ARF7751CAx, boot mode factory value/settings is Boot selection = « D » (BD).

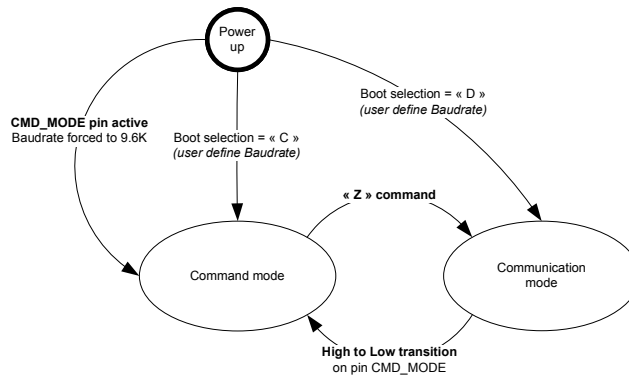

Note : when using the CMD\_MODE pin, the low level («Active») must be held until the '>' char is transmitted on UART\_TX.

Since x4.xx and x3.02 the command mode can be accessed by sending the following « +++ » sequence

**(n x) 0xFF 0xFD 0x2B 0x2B 0x2B**

Example: 0xFF 0xFF 0xFF 0xFF 0xFF 0xFF 0xFF 0xFF 0xFF 0xFF 0xFF 0xFD 0x2B 0x2B 0x2B

with :

- n > 10 ; recommended value. CAUTION: If n is too low the « +++ » sequence can be ignored and discarded silently by the module.
- When the « +++ » sequence is successfully interpreted the '>' is feedback on the serial line
- Don't use the « +++ » sequence when the module is already in command mode

## 5.2. Command Mode

In command mode the user is able to send command to the module in order to configure its parameters (radio parameters, serial parameters, communications parameters, etc.). In this mode, the module does not go in sleep mode or standby mode, it is expecting data transfer in the serial links. The chapter command interface describes all the commands which are available.

### Command Interface

The command interface consists of a set of commands enabling the user to configure the radio module.

The following table is showing all commands available in RTU modules, it is important to mention that for each command sent to the module provides a mean to check whether the command was valid or not: with the UART serial link, the module is returning the character ">" for valid commands, and "#" in case of either an invalid command, a wrong argument, or a wrong parameter.

#### The commands columns (1 & 2):

The first column provides the character that can be used via a HyperTerminal to program the module, while the 2nd column is the hexadecimal value to be use in standard serial link programming.

#### The parameters column (4 & 5):

The 4th column provides the list of character that can be use via HyperTerminal to set the module parameter, while the 5th column is the hexadecimal value to be use in standard serial link programming.

Command		Parameter			Description	Default value
Char	Hex	Char	Hex			
<b>Radio Group</b>						
"L"	0x4C	Meter role (Tx) Other role (Rx)	"M" "O"	0x4D 0x4F	WMBUS Link role selection meter or other	«O» Other role for ARF7751CB «M» meter mode for other references

Radio mode selection						
"M"	0x4D	Mode S1 short preamble (S1-m)	"S"	0x53		T1 Mode for ARF7751CB  R mode for other references
		Mode S1 long preamble	"L"	0x4C	S1-m, S1, T1, R «one way», S2, T2, R	
		Mode R «one way»	"R"	0x52		
		Mode T1	"T"	0x54		
		Mode R	"r"	0x72		
		Mode S2, short preamble	"s"	0x73		
		Mode T2	"t"	0x74		
		Mode C1 format A	A		Transmit / receive C1 frame with format A	
		Mode C1 format B	B		Transmit / receive C1 frame with format B	
		Mode C1	C		« FOR UNIVERSAL » receiver : Able to receive 3 kinds of frame : T, C1 format A and C1 format B	
"C"	0x43	T, C1 format A and C1 format B	"0" to "9"	0x30 to 0x39	Canal selection in R mode	4
Radio Group						
"P"	0x50	Power: -8dBm	"0"	0x30	Power selection	"7": 13dBm
		Power: -5dBm	"1"	0x31		
		Power: -2dBm	"2"	0x32		
		Power: +1dBm	"3"	0x33		
		Power: +4dBm	"4"	0x34		
		Power: +7dBm	"5"	0x35		
		Power: +10dBm	"6"	0x36		
		Power: +13dBm	"7"	0x37		
General group						
"B"	0x42	Boot in command mode	"C"	0x43	Boot selection	<ul style="list-style-type: none"> <li>«D» Data mode for ARF7751CB</li> <li>"C" Command mode for other reference</li> </ul>
		Boot in Data mode (communication)	"D"	0x44		
"G"	0x47	Power management mode selection			In meter mode, the module has to be set in standby mode  In Other mode, the module can be set to Continuous Rx mode or Wake on radio mode	"0"
		Continuous Rx mode	"0"	0x30		
		Standby mode	"1"	0x31		
		Wake on radio mode	"2"	0x32		
"N"	0x4E	Number of preamble bytes coded on 16 bits (MSB byte has to be sent first)		0x0000 to 0xFFFF	Number of Preamble bytes 0x0000 : default number of preamble byte according the minus required by the WMBUS mode selected To 0xFFFF: allows up to 2 seconds preamble duration	0x00 = default number of preamble byte according the minus required by the WMBUS mode selected
"W"	0x57	Wake up time period coded on 16 bits (MSB byte has to be sent first)		0x0000 to 0xFFFF	Wake up time period Defines the periodic wakeup time in other mode when Wake on radio mode is used (expressed in number of preamble byte of the received frame) 0x0000 : minimum wake up time for the current WMBUS selected mode	0x0000 : minimum wake up time for the current WMBUS selected mode
"S"	0x53	None			Save parameter in non volatile memory	na
"Z"	0x5A	None			Quit command mode, and go in communication mode (Data mode)	na

Command	Parameter				Description	Default value
<b>WMBUS Group</b>						
"I"	0x49	8 characters to be sent:  2 ID  6 Address		8 chars to be sent for manufacturer ID + WMBUS address	Settings of the manufacturer ID (first 2 characters) and manufacturer address (last 6 characters). [ID1][ID2][@1][@2][@3][@4][@4][@5][@6]	Each ARF module address is unique when using the default ARF manufacturer ID
«F»	0x46	C field			C Field to be set in WMBUS frame	0x44
<b>Communication Group</b>						
"U"	0x55	115200bps	"3"	0x33	Set the UART bit rate	"3": 115200bps
<b>Filtering Group</b>						
"H"	0x48	Frame filtering activation	"0"	0x30	Not Activated	"0": filtering deactivated
			"1"	0x31	Activated	
"D"	0x44	Manufacturer ID used for filtering		2 char to be sent for manufacturer ID		0x0646 (ARF manufacturer ID)
"J"	0x4A	Upper WMBUS filtering address		6 char to be sent for high WMBUS address		0xFFFFFFFF
"K"	0x4B	Lower WMBUS filtering address		6 char to be sent for low WMBUS address		0x000000000000
<b>Advanced group</b>						
«a,b»		Bidirectional settings			Refer to technical notes (please contact Adeunis RF)	a : 0x0000 b : 0x0000
«c,j»		Synchronous cyclic retransmission				c : 0x000000 j : «0»
«h»		OMS/AES modes				«0»

### 5.3. Communication mode

When the module is set in communication mode the user is able to exchange data with a remote module. The communication is always half-duplex.

Explanations given in these paragraphs for T1 mode are applicable for C1 mode. For selecting the appropriate C1 mode use command MA or MB instead of MT.

The C1 mode MB is the most efficient mode regarding the energy budget : In C1 mode with frame format B (MB), the transmission of a frame with a payload of 100 bytes takes about 11 ms, while in T1 mode you can send only a 50 bytes payload for the same duration. For other configuration, for being able to receive T mode frame, C1 format A and B frame you must choose MC. Then you will have an « Universal » receiver.

The communication mode is called asynchronous mode as there is no coordination in the way the modules will access the radio channel. So when a module is configured in one way, asynchronous mode (S1, T1, R "one way") the data coming on its serial interface will be immediately sent over the radio link without any consideration regarding the radio channel availability. As a consequence it is up to the user's application protocol to manage the access to the radio channel in order to avoid packets collision between equipments.

In communication mode, the packet sent over the air follow the frame format of Wireless M-Bus protocol, but the exchange between the host

and the module is a subset of this Wireless M-Bus frame definition. See packet format paragraph.

In this mode the module can send or receive data following Wireless-MBus protocol with others modules. In this protocol, there are various modes to exchange data with remote modules:

- Mode T1: Asynchronous mode, any data coming on its serial interface will be immediately sent over the radio link by the module. Data Rate 100kpbs
- Mode S1: Idem as above, Asynchronous mode, but the data rate is around 32kbps (two versions exist; one with short preamble and one with long preamble)
- Mode R "one way": Idem as above, Asynchronous mode, but the data rate is around 4.8kbps
- Mode R: In this mode, the packet are sent (from "meter") only if they received an "OK to send" from remote module (other). The data rate is around 4,8kbps
- Mode T2: In this mode, the "meter" requests the "other" equipment before sending its data with a data rate either 100kbps or 32kbps
- Mode S2: In this mode, the meter sends its data directly to the other with a data rate of 32.768 kbps,

The module reaches this mode either after the boot (reset or power up), or after exiting the command mode.

### 5.3.1 One way mode

The following settings have to be applied to the module to get a valid transmission:

#### 5.3.1.01 Quick setup of meter:

Enter the module command mode (refer entering command mode chapter)

- Select WMBUS meter mode by sending "LM" command
- Select WMBUS radio mode :
  - Send "MS" command to select S1 mode
  - Send "MT" command to select T1 mode
  - Send "MR" command to select R "one way" mode
- Select power mode using "G1" command.
  - G1 is the only available mode for meter operation. In this mode, the module is in low power mode while there is no frame to be transmitted. The module is wakeup when an incoming frame is catch from UART interface and go back to sleep mode when the frame has been transmitted.
- Save parameter in non volatile memory using "S" command
- Exit command mode using "Z" command

#### 5.3.1.02 Quick setup of other module:

The other module can be configured for continuous reception mode

- Select WMBUS other mode by sending "LO" command
- Select WMBUS radio mode :
  - Send "MS" command to select S1 mode
  - Send "MT" command to select T1 mode
  - Send "MR" command to select R "one way" mode
- Select power mode using "G0" command.
  - With G0 mode, the radio part of the module is continuously on to listen for incoming frame. When a frame is demodulated, it is transmitted on the UART.
- Save parameter in non volatile memory using "S" command
- Exit command mode using "Z" command

#### 5.3.1.03 Data transfer with T1 S1 R «one way» mode

The data are transmitted from "meter" to "other". The host controller sends its data to the WMBUS module according to the packet format described below. The module is wakeup and data are transmitted to the "other" module under WMBUS frame format selected. The module then send the ACK char ('>') when transmission has been performed or a NACK char ('#') if data from meter cannot be interpreted. The "meter" then sleeps again until some new data are transmitted from the host controller.

On the "other" side, the frame send by the meter is demodulated and transmitted on UART Tx line. With G0 mode, the receiver is coming back to reception mode immediately while in G2 mode, the receiver performs a periodic wakeup cycle to listen for incoming frame.

### 5.3.2 Two way mode

The following figure explains how to achieve the bidirectional set-up and exchange. For detailed information (commands to be used and parameters settings) please read the bidirectional application note available on request.

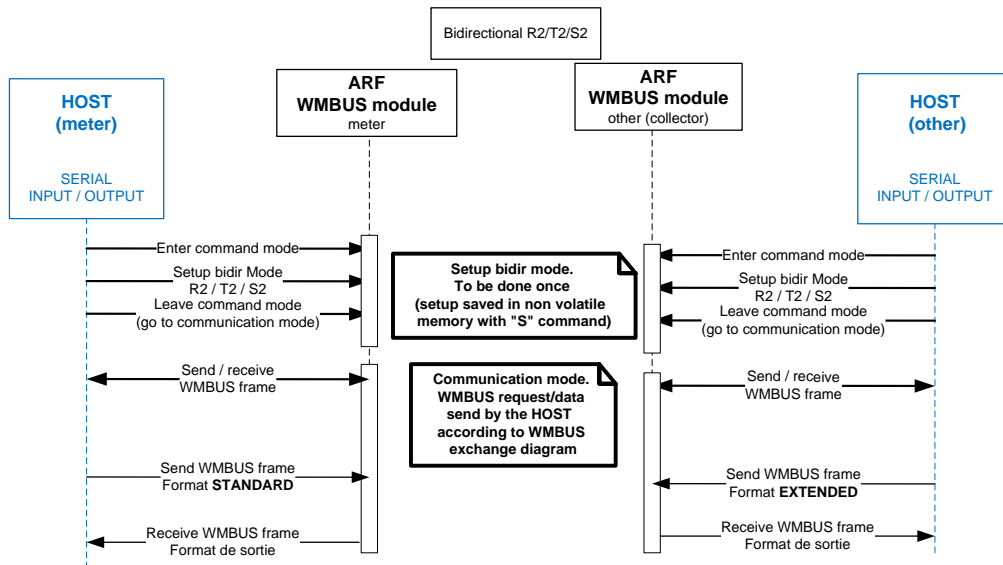

#### 5.3.2.01 T2 use cases overview

T2 mode: The meter sends periodically (seconds-minutes) an access demand; request; on ACK reception the meter waits for an incoming data request and sends a user data respond.

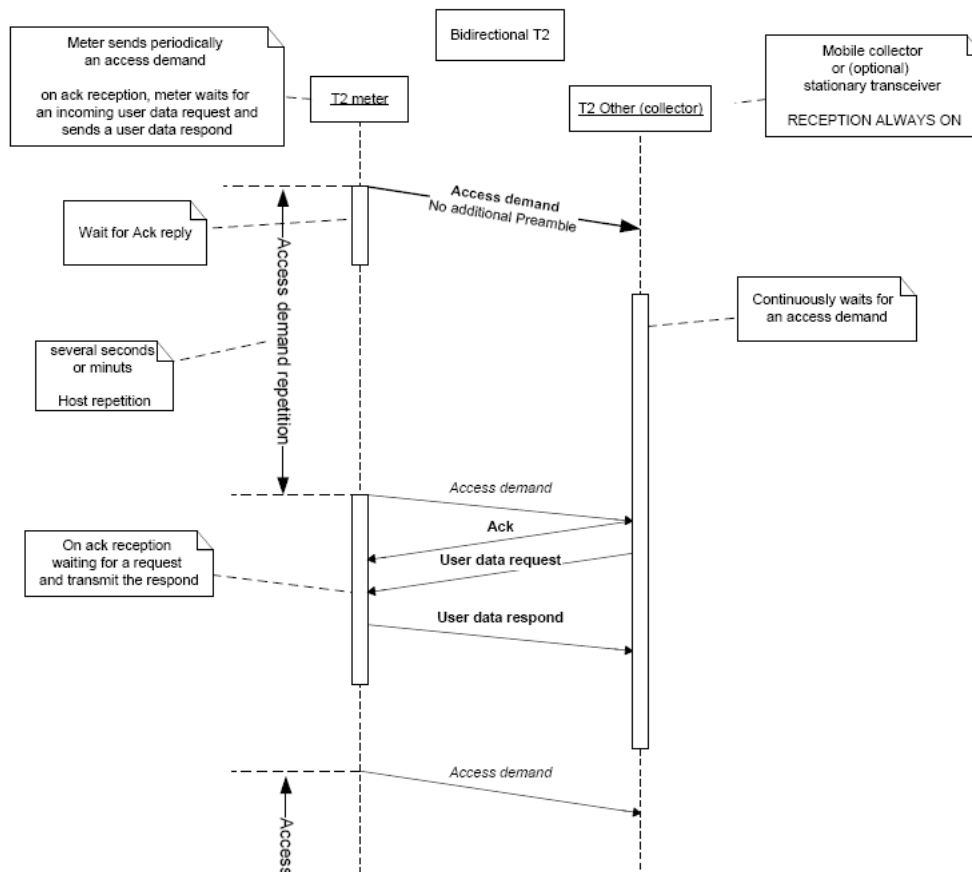

### 5.3.2.02 R2 Use cases overview

R2 mode: The collector sends periodically a data request; The Meter wake-up periodically (few seconds) and responds to data request.

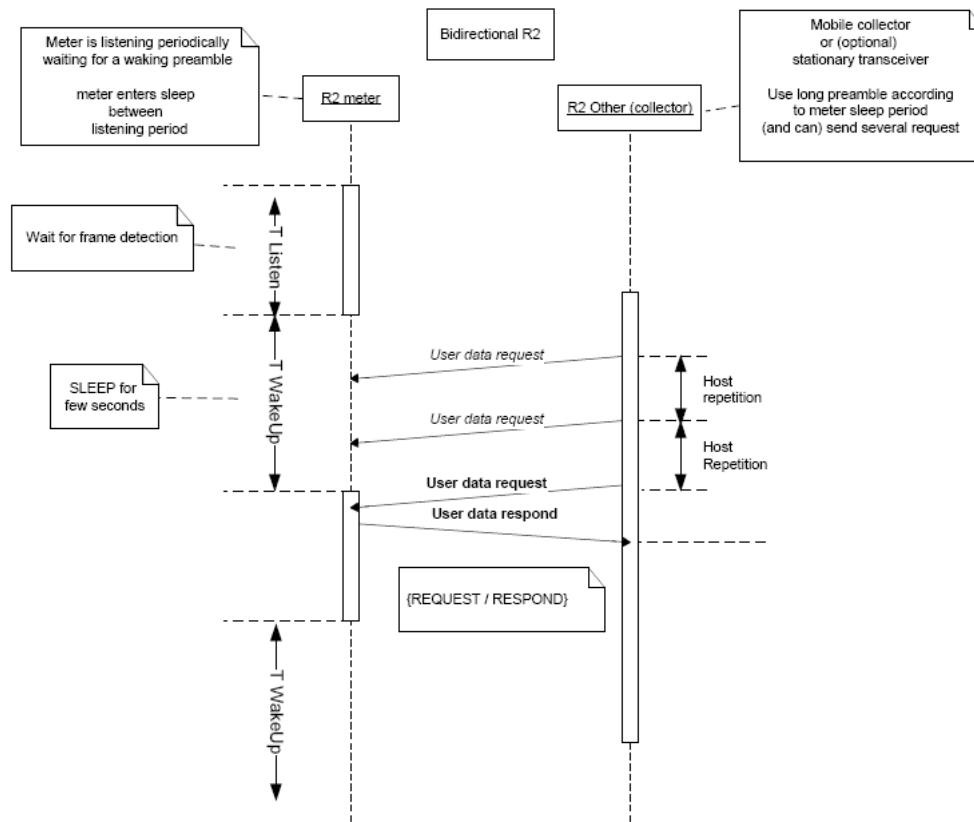

### 5.3.2.03 S2 Use cases overview

S2 mode: The meter sends periodically (seconds-minutes) its data; After data transmission the meter waits for an optional incoming status request.

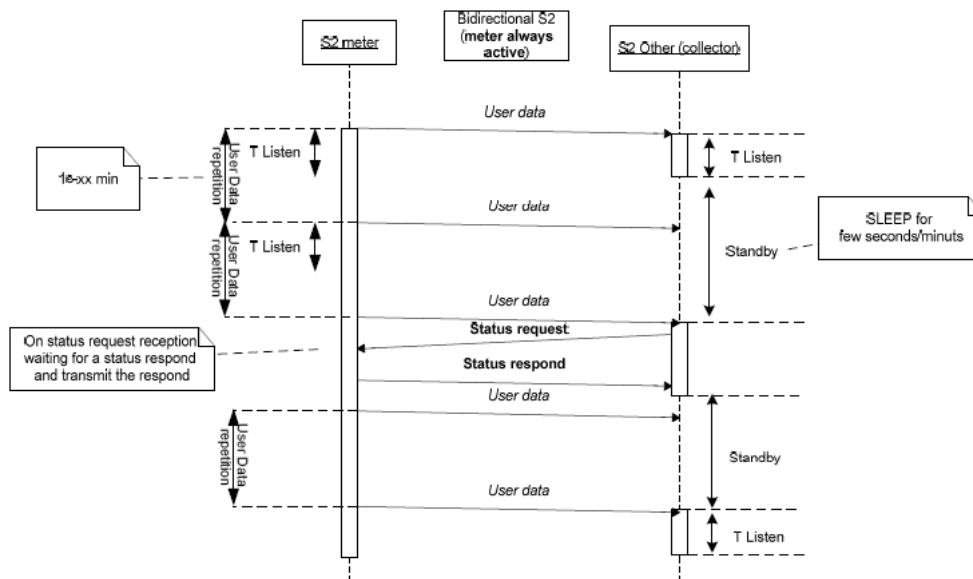

Figure 4: S2 overview, active meter

### S2 Mode - Active collector

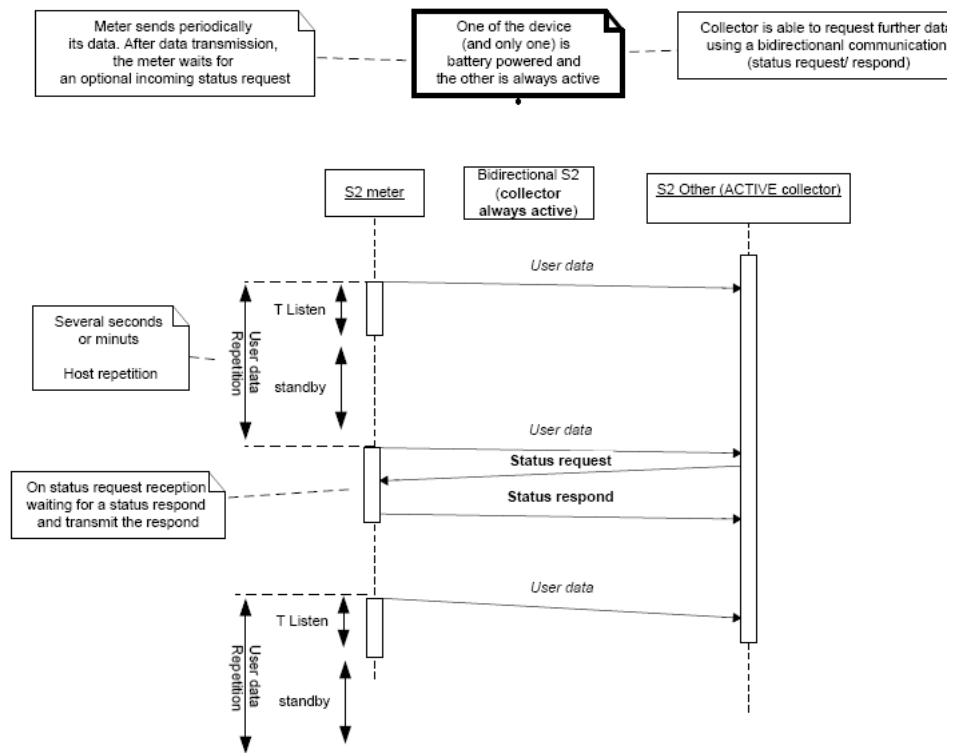
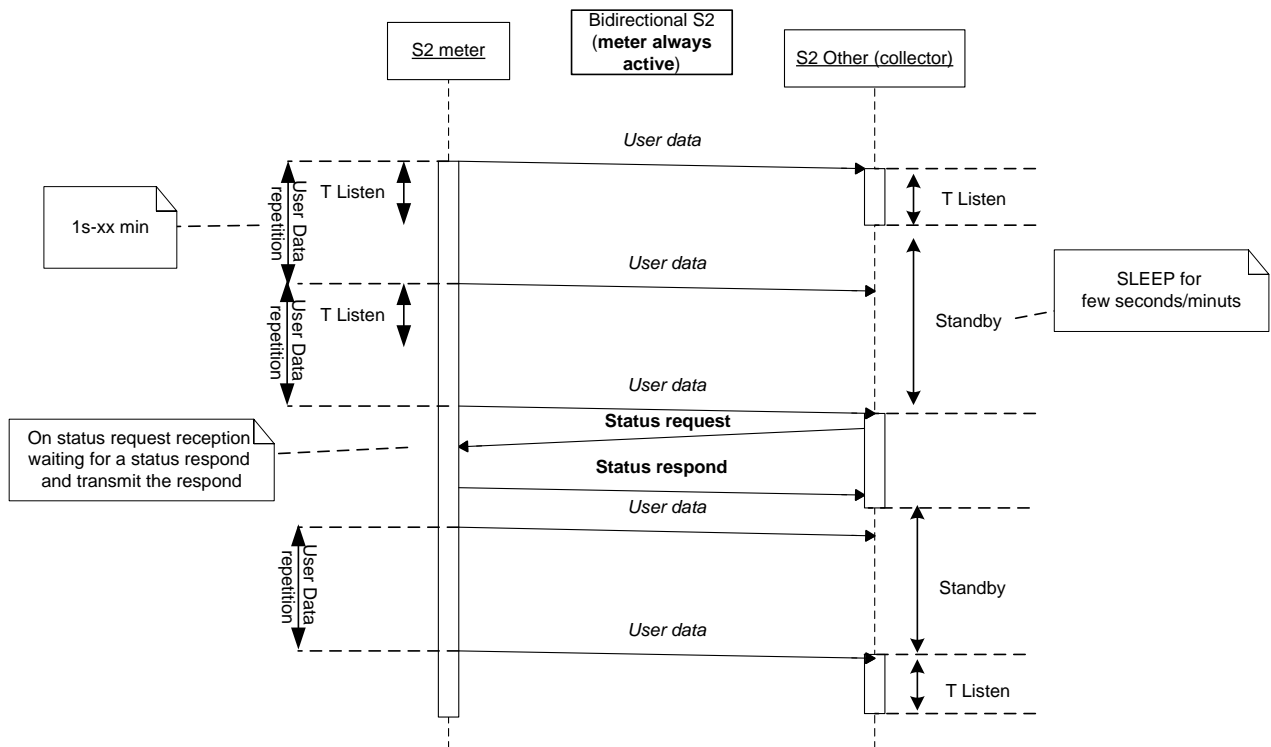

Figure 3: S2 overview, active collector

### S2 Mode - Active meter



### 5.4. Packet format

Find below a description of the Adeunis-RF Wireless-MBus packet format:

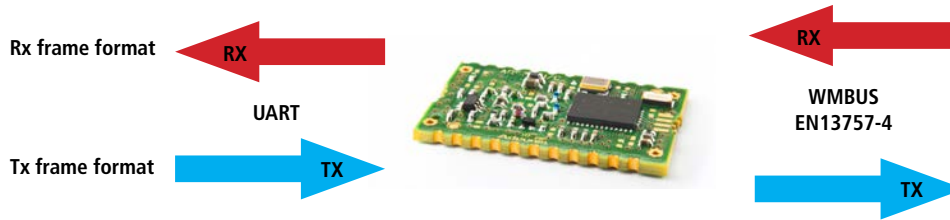

Tx or RX frame format, is the packet data exchanged between the module and the host, while the data transmitted over the air follow the Wireless M-Bus protocol framing, which includes Preamble, Synchro, Wireless M-Bus Encapsulation, encoded data, and CRC. The frame format A and B of the link layer are supported according to EN13757-4 :2013.

### 5.5. Tx frame format (Host to Module)

The module, to send any data over the air, must receive a packet format on the serial link with the following format:

0xFF	0xFF	Length	CI	Data
1 Byte	1 Byte	1 Byte	1 Byte	From 1 Byte to 245 Bytes
Wake-up Byte.	Start of frame	Define the length in Bytes of the Data section. Maximum length is 245 for T mode and 213 byte for other modes.	CI Field to be sent in the Tx Frame	Payload Max=245 mode T, C1A Max = 241 mode C1B Max= 245 modes R/S

### 5.6. Tx frame extended format (Host to Module)

This format is reserved to the bidirectional mode on «Other» side.

0xFF	0xFE	Length	M&A	CI	Data
1 Byte	1 Byte	1 Byte	2+6 Bytes	1 Byte	From 1 Byte to 245 Bytes
Wake-up Byte.	Start of frame	Define the length in Bytes of the Data section. Maximum length is 245 for T mode and 213 byte for other modes.	Manufacturer ID and address	CI Field to be sent in the Tx Frame	Payload Max=245 mode T, C1A Max =241 mode C1B Max= 213 modes R/S
		Must be set to 0 in R Other mode to request a frame from meter.		Must be left empty in R Other mode when Length field equals 0	Must be left empty in R Other mode when Length field equals 0

### 5.7. Rx frame format (Module to Host)

On radio frame reception, the module transmits the data on the serial link with the following format:

0xFF	Length	C	M & A	CI	Data	RSSI
1 Bytes	1 byte	1 Byte	2 + 6 Bytes	1 Byte	From 1 Byte to 245 Bytes	1 Byte
Wake-up Byte sent in UART mode from Module to Host. This wake-up byte can be used to wake-up the host if needed. In SPI mode, this bit is not available, the host reads directly the ACK/NACK.	Define the length in Bytes of the Data section. Maximum length is 245.  This Length is set to 0, in case no frame has been received	WMBUS C Field in the Rx received frame	WMBUS Manufacturer ID and Address of WMBUS received frame	WMBUS CI Field in the Rx received frame	Data received. 245Bytes max.	RSSI Level of Rx Frame. 0 => -125dBm 1 => -124,5dBm  X => -125 + x*0,5 dBm  255 => 2,5dBm

## 6. Other functionalities

### 6.1. Low Power Mode

Radio polling for receiver ( Other) energy saving ( battery operated, ...) devices. The additional energy cost for the transmitter ( Meter) is very low if you don't need to send frame very often.

How it works :

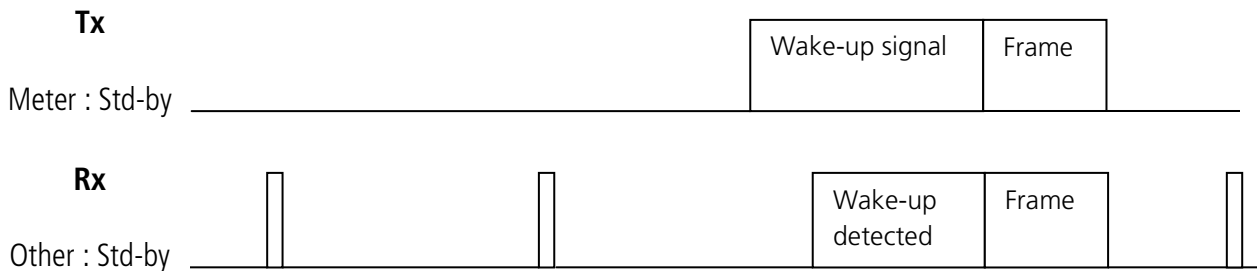

The wake-up period of the receiver (Other) and the preamble length of the transmitter( Meter) should be the same.

The other module can be configured for low power reception mode

- Select WMBUS other mode by sending "LO" command
- Select WMBUS radio mode :
  - Send "MS" command to select S1 mode
  - Send "MT" command to select T1 mode
  - Send "MR" command to select R "one way" mode
- Select power mode using "G2" command.
  - With G2 mode, the radio part of the module listen the radio periodically and stay in sleep mode for the remaining time.
  - There is no action required from host application to wake up the module. This is done automatically according the wake up period set in "W" command when "G2" is selected. This mode requires some preamble set with length according to the wake period of the other device. When a frame is demodulated, it is transmitted on the UART.
- Save parameter in non volatile memory using "S" command
- Exit command mode using "Z" command

### 6.2. Set-up of preamble length and periodic wakeup time

Setting preamble length (meter side) and periodic wakeup time (other side) for G2 operation mode.

Note : you must configure the same value for N and W if you want the radio polling to work.

#### S1 mode:

Minimum Preamble length: 41 bytes

Maximum Preamble length: 8192 bytes (ie 2 seconds with a data rate of 32.768kbps)

On "meter" side, the preamble length is set with command "N". "N0029" will set the preamble length to 41 bytes. On "other" side, the wake up period has to be set with command "W" set to the same value as the "N" command on meter ("W0029").

#### T1 mode:

Minimum Preamble length: 81 bytes

Maximum Preamble length: 25000 bytes (ie 2 seconds with a data rate of 100kbps)

On "meter" side, the preamble length is set with command "N". "N0051" will set the preamble length to 81 bytes. On "other" side, the wake up period has to be set with command "W" set to the same value as the "N" command on meter ("W0051").

#### R mode "one way":

Minimum Preamble length: 15 bytes

Maximum Preamble length: 1200 bytes (ie 2 seconds with a data rate of 4.8kbps)

On "meter" side, the preamble length is set with command "N". "N000F" will set the preamble length to 15 bytes. On "other" side, the wake up period has to be set with command "W" set to the "N" command value of meter "W000F".

### 6.3. OMS Encryption (Module ARF7751CA/CB)

ARF Module supports OMS3.0.1, encryption mode 5: the AES-encryption uses a block size of 16 Bytes and a 128 Bit key with cipher block chaining. The CBC (Cipher Block Chaining) encryption for AES128 uses a dynamic 128 bit (16 Byte) initialisation vector to start the encryption of the first block.

The link layer header (including ID) and the fixed 4-bytes or 12-bytes header after the CI-field, are never encrypted

Please contact us for more detailed information.

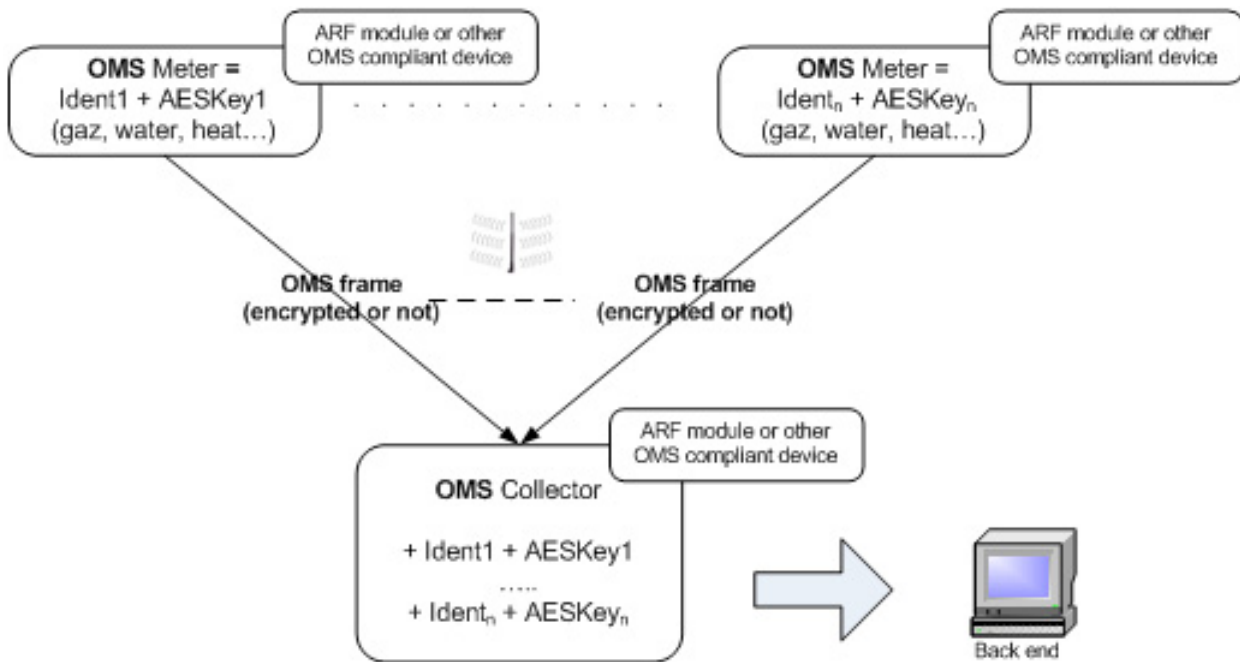

### 6.4. Cyclic synchronous retransmission (OMS support)

Cyclic retransmission feature allows to transmit synchronously a WMBUS frame. The frame is transmitted with a predefined interval. The frame content can be updated via the serial link.

This feature is usable:

- On meter mode unidirectional, T1/S1/R1. (cannot be used in bidirectional mode).
- The long preamble is not supported

To preserve the synchronization during a frame update, avoid to update the frame when the frame transmission is in progress (end of interval). A simple way to do this is to refresh the frame after the transmission, when the module feedbacks the character '>' (transmission performed).

In this mode, you can activate the following options:

- Usage of a transmission jitter. The transmission jitter is based on OMS requirement (allow to have a jitter from +/- 0.62 ms up to +/- 166s with duration from 2s up to 5400s). For durations > 5400s, the jitter is limited to +/- 166s.
- Auto-incrementation of the access number for OMS frame content (with Ci 0x72 and 0x7A) activating OMS 5 allows to transmit an encrypted message using each time a different access number.

Please contact us for more detailed information.

### 6.5. Specific ARF-AES128 encryption (Module ARF7751CA/CB)

ARF-AES encryption (decryption) is performed:

- On data field,
- for each block of 16 data bytes ; If the last block is not 16 bytes long, the block will be transmitted without encryption.
- The encryption of each block is performed using and the preset initialization vector.

Please contact us for more detailed information.

#### 6.5.1 Typical ARF-AES128 use cases

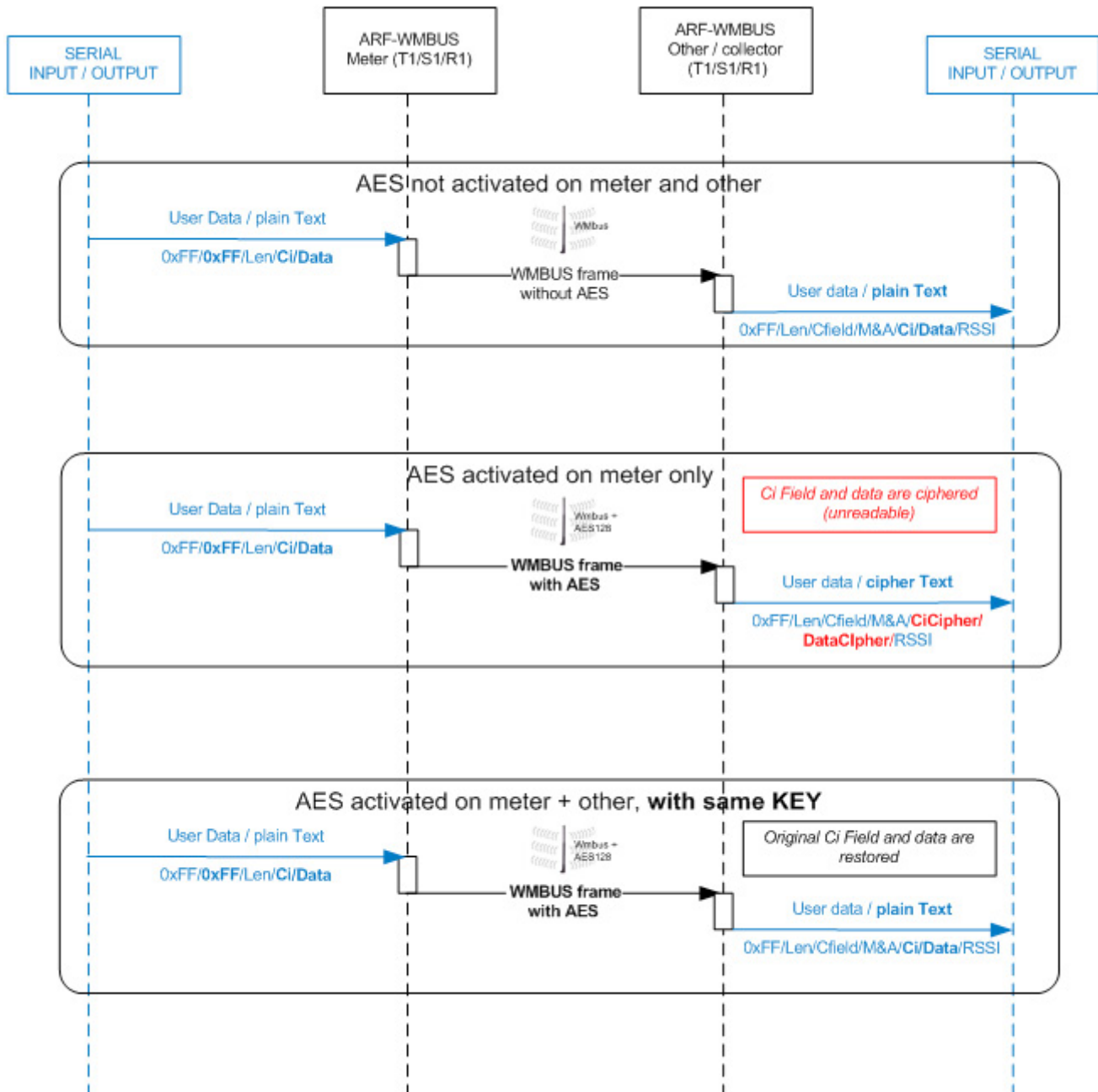

## 6.6. Specific frame output format

A specific output format is available for compatibility with other WMBUS products.

Please contact us for more detailed information.

## 7. Version history

User guide version	Contents
V2.3	Mode C description
V2.2	Mode R Channels added (p15), channel default value modified (p17)
V2.1	Pin out description modified
V2.0	Document created