

A decorative graphic on the left side of the page, consisting of a large dashed circle, a solid blue circle, and several overlapping curved lines in blue and grey.

Product Manual

DB35.3[®] Series 80-160GB

SATA

ST3160215SCE
ST380215SCE

PATA

ST3160215ACE
ST380215ACE

100439554
Rev. F
August 2007

Copyright © 2006-2007 Seagate Technology LLC. All rights reserved. Printed in USA

Publication number: 100439554, Rev. F
August 2007

Seagate, Seagate Technology and the Wave logo are registered trademarks of Seagate Technology LLC in the United States and/or other countries. DB35.3 Series, SeaTools and SeaTDD are either trademarks or registered trademarks of Seagate Technology LLC or one of its affiliated companies in the United States and/or other countries. All other trademarks or registered trademarks are the property of their respective owners.

One gigabyte, or GB, equals one billion bytes when referring to hard drive capacity. Accessible capacity may vary depending on operating environment and formatting. Seagate reserves the right to change, without notice, product offerings or specifications.

Contents

1.0	Introduction	1
1.1	About the Serial ATA interface	2
2.0	Drive specifications	3
2.1	Specification summary table	3
2.1.1	Formatted capacity	6
2.1.2	Default logical geometry	6
2.1.3	Recording and interface technology	6
2.1.4	Physical characteristics	7
2.1.5	Seek time	7
2.1.6	Start/stop times	7
2.1.7	Power specifications	8
2.1.8	Environmental specifications	11
2.1.9	Acoustics	12
2.2	Electromagnetic immunity	13
2.3	Reliability	13
2.4	Agency certification	14
2.4.1	Safety certification	14
2.4.2	Electromagnetic compatibility	14
2.4.3	FCC verification	14
2.5	Environmental protection	16
2.5.1	European Union Restriction of Hazardous Substances (RoHS) Directive	16
2.5.2	China Restriction of Hazardous Substances (RoHS) Directive	16
2.6	Corrosive environment	16
3.0	Handling, mounting and configuring the drive	17
3.1	Handling and static discharge precautions	17
3.2	Mounting the drive	18
3.3	Breather filter hole precautions	19
3.4	How to configure and attach Serial ATA (SATA) drives	20
3.4.1	How to configure the drive	20
3.4.2	How to connect the SATA cables	20
3.5	How to configure and attach the Parallel ATA (PATA) drives	21
3.5.1	How to set the jumper settings	21
4.0	Interface	23
4.1	Serial ATA (SATA) interface	24
4.1.1	Hot-Plug compatibility	24
4.1.2	Serial ATA device plug connector pin definitions	24
4.2	Parallel ATA (PATA) Interface	26
4.2.1	ATA interface signals and connector pins	26
4.3	Supported ATA commands	27
4.4	Identify Device command	29
4.5	Set Features command	32
4.6	S.M.A.R.T. commands	33
5.0	Seagate Technology support services	35

List of Figures

Figure 1.	Representative 5V startup and operation current profile	9
Figure 2.	Representative 12V startup and operation current profile	9
Figure 3.	Mounting dimensions for PATA/SATA drives —top, side and end view.	18
Figure 4.	Breather filter hole location	19
Figure 5.	Serial ATA connectors	20
Figure 6.	Attaching SATA cabling	20
Figure 7.	Master/slave jumper settings	21
Figure 8.	Ultra ATA cable connectors	22
Figure 9.	I/O pins and supported ATA signals	26

1.0 Introduction

This manual describes the functional, mechanical and interface specifications for the following Seagate® DB35.3® Series SATA/PATA model drives:

SATA models	PATA models
ST3160215SCE	ST3160215ACE
ST380215SCE	ST380215ACE

The drives provide the following key features:

- 7,200-RPM spindle speed.
- Tunneling Magnetoresistive (TMR) recording heads.
- Low profile deck design for improved air-flow and low-profile system design.
- State-of-the-art cache and on-the-fly error-correction algorithms.
- Full-track multiple-sector transfer capability without local processor intervention.
- Quiet operation.
- SeaTools diagnostic software performs a drive self-test that eliminates unnecessary drive returns.
- Support for S.M.A.R.T. drive monitoring and reporting.

SATA specific key features:

- High instantaneous (burst) data-transfer rates (up to 300 Mbytes per second).
- Native Command Queueing with command ordering to increase performance in demanding applications.
- Supports latching SATA cables and connectors.

PATA specific key features:

- High instantaneous (burst) data transfer rates (up to 100 Mbytes per second) using Ultra DMA mode 5.
- Support for Read Multiple and Write Multiple commands.
- Support for autodetection of master/slave drives that use cable select (CSEL).

1.1 About the Serial ATA interface

The Serial ATA interface provides several advantages over the traditional Parallel ATA interface. The primary advantages include:

- Easy installation and configuration with true plug-and-play connectivity. It is not necessary to set any jumpers or other configuration options.
- Thinner and more flexible cabling for improved enclosure airflow and ease of installation.
- Scalability to higher performance levels.

In addition, Serial ATA makes the transition from Parallel ATA easy by providing legacy software support. Serial ATA was designed to allow you to install a Serial ATA host adapter and Serial ATA disc drive in your current system and expect all of your existing applications to work as normal.

The Serial ATA interface connects each disc drive in a point-to-point configuration with the Serial ATA host adapter. There is no master/slave relationship with Serial ATA devices like there is with Parallel ATA. If two drives are attached on one Serial ATA host adapter, the host operating system views the two devices as if they were both “masters” on two separate ports. This essentially means both drives behave as if they are Device 0 (master) devices.

Note. The host adapter may, optionally, emulate a master/slave environment to host software where two devices on separate Serial ATA ports are represented to host software as a Device 0 (master) and Device 1 (slave) accessed at the same set of host bus addresses. A host adapter that emulates a master/slave environment manages two sets of shadow registers. This is not a typical Serial ATA environment.

The Serial ATA host adapter and drive share the function of emulating Parallel ATA device behavior to provide backward compatibility with existing host systems and software. The Command and Control Block registers, PIO and DMA data transfers, resets, and interrupts are all emulated.

The Serial ATA host adapter contains a set of registers that shadow the contents of the traditional device registers, referred to as the Shadow Register Block. All Serial ATA devices behave like Device 0 devices. For additional information about how Serial ATA emulates parallel ATA, refer to the “Serial ATA: High Speed Serialized AT Attachment” specification. The specification can be downloaded from www.serialata.org.

2.0 Drive specifications

Unless otherwise noted, all specifications are measured under ambient conditions, at 25°C, and nominal power. For convenience, the phrases *the drive* and *this drive* are used throughout this manual to indicate the following drive models:

SATA models	PATA models
ST3160215SCE	ST3160215ACE
ST380215SCE	ST380215ACE

2.1 Specification summary table

The specifications listed in the table below are for quick reference. For details on specification measurement or definition, see the appropriate section of this manual.

Table 1: Drive specifications summary for 160 and 80 Gbyte models

Drive specification	ST3160215SCE, ST3160215ACE	ST380215SCE, ST380215ACE
Formatted Gbytes (512 bytes/sector)*	160	80
Guaranteed sectors	312,581,808	156,301,488
Bytes per sector	512	
Default sectors per track	63	
Default read/write heads	16	
Default cylinders	16,383	
Recording density, max	824 kbits/in	
Track density, max	140 ktracks/in	
Areal density, max	116.2 Gbits/in ²	
Spindle speed	7,200 RPM	
Internal data transfer rate, max	930 Mbits/sec	
Sustained data transfer rate, max	78 Mbytes/sec	
I/O data-transfer rate, max	300 Mbytes/sec (SATA models) 100 Mbytes/sec (PATA models)	
ATA data-transfer modes supported	PIO modes 0–4 Multiword DMA modes 0–2 Ultra DMA modes 0–5	
Cache buffer	2 Mbytes	
Height, max	20.2 mm (0.794 inches)	
Width, max	101.6 mm (4.000 inches)	
Length, max	146.6 mm (5.772 inches)	
Weight, typical	380 grams (0.838 lb.)	370 grams (0.816160GB: lb.)
Average latency	4.16 msec	
Power-on to ready, max	16 sec	
Standby to ready, max	16 sec	
Track-to-track seek time, typical	<1.0 msec read <1.2 msec write	
Average seek, read, typical	<14.0 msec	
Average seek, write, typical	<15.0 msec	
Startup current (typical) 12V (peak)	2.0 amps	
Voltage tolerance (including noise)	5V ± 5% 12V ± 10%	
Temperature gradient, max	20°C (operating) 30°C (nonoperating)	
Relative humidity	5% to 90% (operating) 5% to 95% (nonoperating)	
Relative humidity gradient, per hour max	30%	
Wet bulb temperature, max	37.7°C (operating) 40.0°C (nonoperating)	
Altitude, operating	–60.96 m to 3,048 m (–200 ft. to 10,000+ ft.)	
Altitude, nonoperating, max	–60.96 m to 12,192 m below mean sea level (–200 ft. to 40,000+ ft. below mean sea level)	
Operational Shock, max	63 Gs at 2 msec	
Non-Operational Shock, max	350 Gs at 2 msec	
Vibration, operating	5–350 Hz: 0.50 Gs	
Vibration, nonoperating	5–350 Hz: 5.0 Gs	

Drive specification	ST3160215SCE, ST3160215ACE	ST380215SCE, ST380215ACE
Drive acoustics, sound power Idle**	2.6 bels (typical) 2.8 bels (max)	
CE seek profile	2.7 bels (typical) 2.8 bels (max)	
Nonrecoverable read errors	1 per 10 ¹⁴ bits read	
Annualized Failure Rate (AFR)***	0.68%	
Warranty	5 years on distribution units. To determine the warranty for a specific drive, use a web browser to access the following web page: www.seagate.com/support/service/ From this page, click on the "Verify Your Warranty" link. You will be asked to provide the drive serial number, model number (or part number) and country of purchase. The system will display the warranty information for your drive.	
Contact start-stop cycles (25°C, 50% rel. humidity)	50,000	
Supports Hotplug operation per Serial ATA Revision 2.5 specification	Yes	

* One Gbyte equals one billion bytes when referring to hard drive capacity. Accessible capacity may vary depending on operating environment and formatting.

** During periods of drive idle, some offline activity may occur according to the S.M.A.R.T. specification, which may increase acoustic and power to operational levels.

2.1.1 Formatted capacity

Model	Formatted capacity*	Guaranteed sectors	Bytes per sector
ST3160215SCE, ST3160215ACE	160 Gbytes	312,581,808	512
ST380215SCE, ST380215ACE	80 Gbytes	156,301,488	512

*One Gbyte equals one billion bytes when referring to hard drive capacity. Accessible capacity may vary depending on operating environment and formatting.

2.1.1.1 LBA mode

When addressing these drives in LBA mode, all blocks (sectors) are consecutively numbered from 0 to $n-1$, where n is the number of guaranteed sectors as defined above.

See Section 4.4, "Identify Device command" (words 60-61 and 100-103) for additional information about 48-bit addressing support of drives with capacities over 137 Gbytes.

2.1.2 Default logical geometry

Cylinders	Read/write heads	Sectors per track
16,383	16	63

2.1.3 Recording and interface technology

	160GB	80GB
Interface	Serial ATA and Parallel ATA	
Recording method	Perpendicular	
Recording density, KBPI (kbits/inch max)	824	
Track density, KTPI (ktracks/inch avg)	140	
Areal density (Gbits/inch ² avg)	116.2	
Spindle speed (RPM) (\pm 0.2%)	7,200	
Internal data transfer rate (Mbits/sec max)	930	
Sustained data transfer rate (Mbytes/sec max)	78	
I/O data-transfer rate (Mbytes/sec max)	SATA - 300 PATA - 100 (Ultra DMA mode 5)	

2.1.4 Physical characteristics

Drive specification		
Maximum height	(mm) (inches)	20.2 0.794
Maximum width	(mm) (inches)	101.6 4.000
Maximum length	(mm) (inches)	146.6 5.772
Typical weight		380 grams (0.838 lbs) 160 GB models 370 grams (0.816 lbs) 80 GB models
Cache Size		2 Mbytes

2.1.5 Seek time

Seek measurements are taken with nominal power at 25°C ambient temperature. All times are measured using drive diagnostics. The specifications in the table below are defined as follows:

- Track-to-track seek time is an average of all possible single-track seeks in both directions.
- Average seek time is a true statistical random average of at least 5,000 measurements of seeks between random tracks, less overhead.

Typical seek times (msec)	Read	Write
Track-to-track	<1.0	<1.2
Average	<14.0	<15.0
Average latency	4.16	4.16

Note. These drives are designed to consistently meet the seek times represented in this manual. Physical seeks, regardless of mode (such as track-to-track and average), are expected to meet or exceed the noted values. However, due to the manner in which these drives are formatted, benchmark tests that include command overhead or measure logical seeks may produce results that vary from these specifications.

2.1.6 Start/stop times

Power-on to Ready (sec)	16 (max)
Standby to Ready (sec)	16 (max)
Ready to spindle stop (sec)	10 (max)

2.1.7 Power specifications

The drive receives DC power (+5V or +12V) through a four-pin standard drive power connector.

2.1.7.1 Power consumption

Power requirements for the drives are listed in the table on page 8. Typical power measurements are based on an average of drives tested, under nominal conditions, using +5.0V and +12.0V input voltage at 25°C ambient temperature.

- **Spinup power**

Spinup power is measured from the time of power-on to the time that the drive spindle reaches operating speed.

- **Seek mode**

During seek mode, the read/write actuator arm moves toward a specific position on the disc surface and does not execute a read or write operation. Servo electronics are active. Seek mode power represents the worst-case power consumption, using only random seeks with read or write latency time. This mode is not typical and is provided for worst-case information.

- **Read/write power and current**

Read/write power is measured with the heads on track, based on a 16-sector write followed by a 32-msec delay, then a 16-sector read followed by a 32-msec delay.

- **Operating power and current**

Operating power is measured using 40 percent random seeks, 40 percent read/write mode (1 write for each 10 reads) and 20 percent drive idle mode.

- **Idle mode power**

Idle mode power is measured with the drive up to speed, with servo electronics active and with the heads in a random track location.

- **Standby mode**

During Standby mode, the drive accepts commands, but the drive is not spinning, and the servo and read/write electronics are in power-down mode.

Table 2: DC power requirements

Power dissipation using consumer storage profile (ST3160215ACE values shown)	Average (watts, 25° C)	Average 5V typ amps	Average 12V typ amps
Spinup	—	—	2.0 (peak)
Idle*	5.73	0.665	0.202
Operating (CE seeks)	6.00	0.623	0.237
Standby	0.80	0.106	0.023
Sleep	0.80	0.106	0.023

*During periods of drive idle, some offline activity may occur according to the S.M.A.R.T. specification, which may increase acoustic and power to operational levels.

2.1.7.1.1 Representative current profile

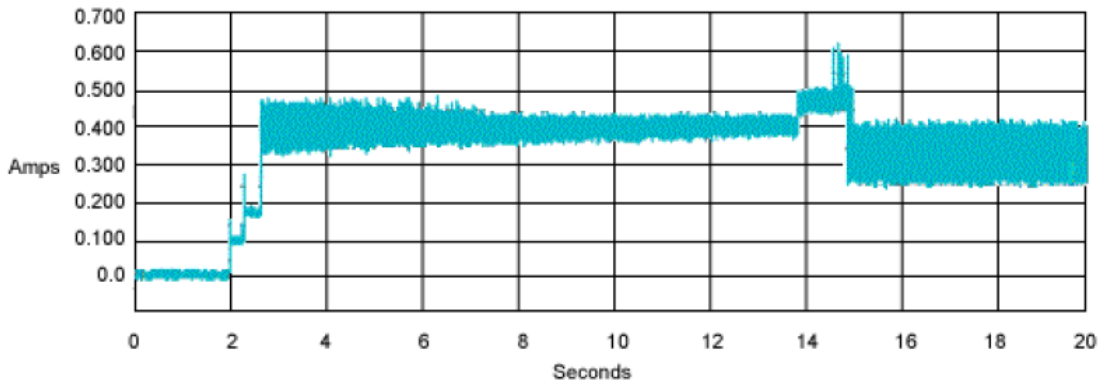

Figure 1 Representative 5V startup and operation current profile

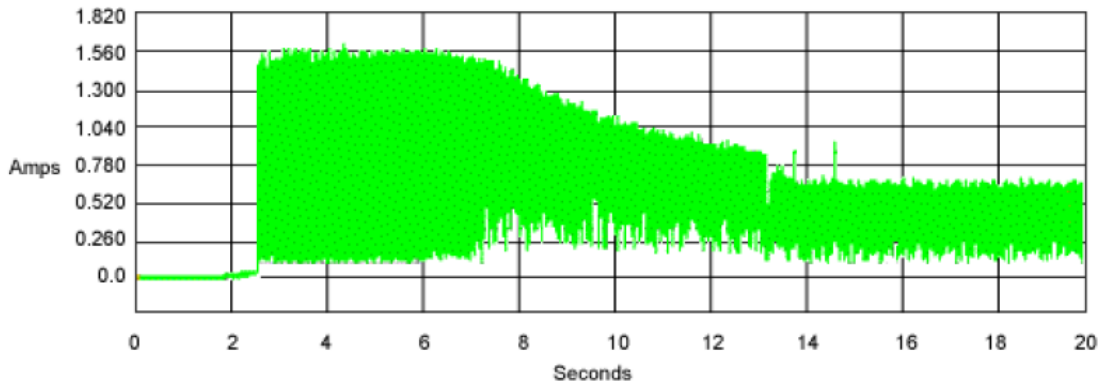

Figure 2 Representative 12V startup and operation current profile

2.1.7.2 Conducted noise

Input noise ripple is measured at the host system power supply across an equivalent 80-ohm resistive load on the +12 volt line or an equivalent 15-ohm resistive load on the +5 volt line.

- Using 12-volt power, the drive is expected to operate with a maximum of 120 mV peak-to-peak square-wave injected noise at up to 10 MHz.
- Using 5-volt power, the drive is expected to operate with a maximum of 100 mV peak-to-peak square-wave injected noise at up to 10 MHz.

Note. Equivalent resistance is calculated by dividing the nominal voltage by the typical RMS read/write current.

2.1.7.3 Voltage tolerance

Voltage tolerance (including noise):

5V \pm 5%
12V \pm 10%

2.1.7.4 Power-management modes

The drive provides programmable power management to provide greater energy efficiency. In most systems, you can control power management through the system setup program. The drive features the following power-management modes:

Power mode	Heads	Spindle	Buffer
Active	Tracking	Rotating	Enabled
Idle	Tracking	Rotating	Enabled
Standby	Parked	Stopped	Enabled
Sleep	Parked	Stopped	Disabled

- **Active mode**

The drive is in Active mode during the read/write and seek operations.

- **Idle mode**

The buffer remains enabled, and the drive accepts all commands and returns to Active mode any time disc access is necessary.

- **Standby mode**

The drive enters Standby mode when the host sends a Standby Immediate command. If the host has set the standby timer, the drive can also enter Standby mode automatically after the drive has been inactive for a specifiable length of time. The standby timer delay is established using a Standby or Idle command. In Standby mode, the drive buffer is enabled, the heads are parked and the spindle is at rest. The drive accepts all commands and returns to Active mode any time disc access is necessary.

- **Sleep mode**

The drive enters Sleep mode after receiving a Sleep command from the host. In Sleep mode, the drive buffer is disabled, the heads are parked and the spindle is at rest. The drive leaves Sleep mode after it receives a Hard Reset or Soft Reset from the host. After receiving a reset, the drive exits Sleep mode and enters Standby mode with all current translation parameters intact.

- **Idle and Standby timers**

Each time the drive performs an Active function (read, write or seek), the standby timer is reinitialized and begins counting down from its specified delay times to zero. If the standby timer reaches zero before any drive activity is required, the drive makes a transition to Standby mode. In both Idle and Standby mode, the drive accepts all commands and returns to Active mode when disc access is necessary.

2.1.8 Environmental specifications

2.1.8.1 Case temperature

Actual drive case temperature should not exceed 75°C (167°F). Recommended measurement locations are shown in Figure 3 on page 18.

Above 1,000 feet (305 meters), the maximum temperature is derated linearly to 44°C (112°F) at 10,000 feet (3,048 meters).

2.1.8.2 Temperature gradient

Operating	20°C per hour (68°F per hour max), without condensation
Nonoperating	30°C per hour (86°F per hour max)

2.1.8.3 Humidity

2.1.8.3.1 Relative humidity

Operating	5% to 90% noncondensing (30% per hour max)
Nonoperating	5% to 95% noncondensing (30% per hour max)

2.1.8.3.2 Wet bulb temperature

Operating	37.7°C (99.9°F max)
Nonoperating	40.0°C (104.0°F max)

2.1.8.4 Altitude

Operating	–60.96 m to 3,048 m (–200 ft. to 10,000+ ft.)
Nonoperating	–60.96 m to 12,192 m (–200 ft. to 40,000+ ft.)

2.1.8.5 Shock

All shock specifications assume that the drive is mounted securely with the input shock applied at the drive mounting screws. Shock may be applied in the X, Y or Z axis.

2.1.8.5.1 Operating shock

These drives comply with the performance levels specified in this document when subjected to a maximum operating shock of 63 Gs based on half-sine shock pulses of 2 msec. Shocks should not be repeated more than two times per second.

2.1.8.5.2 Nonoperating shock

The nonoperating shock level that the drive can experience without incurring physical damage or degradation in performance when subsequently put into operation is 350 Gs based on a nonrepetitive half-sine shock pulse of 2 msec duration.

2.1.8.6 Vibration

All vibration specifications assume that the drive is mounted securely with the input vibration applied at the drive mounting screws. Vibration may be applied in the X, Y or Z axis.

2.1.8.6.1 Operating vibration

The following table lists the maximum vibration levels that the drive may experience while meeting the performance standards specified in this document.

5–350 Hz	0.50 Gs
----------	---------

2.1.8.6.2 Nonoperating vibration

The following table lists the maximum nonoperating vibration that the drive may experience without incurring physical damage or degradation in performance when subsequently put into operation.

5–350 Hz	5.0 Gs
----------	--------

2.1.9 Acoustics

Drive acoustics are measured as overall A-weighted acoustic sound power levels (no pure tones). All measurements are consistent with ISO document 7779. Sound power measurements are taken under essentially free-field conditions over a reflecting plane. For all tests, the drive is oriented with the cover facing upward.

Note. For seek mode tests, the drive is placed in seek mode only. The number of seeks per second is defined by the following equation:

$$(\text{Number of seeks per second} = 0.4 / (\text{average latency} + \text{average access time}))$$

Table 3: Fluid Dynamic Bearing (FDB) motor acoustics

Models	Idle*	Seek profile
All models	2.6 bels (typ) 2.8 bels (max)	2.7 bels (typ) 2.8 bels (max)

*During periods of drive idle, some offline activity may occur according to the S.M.A.R.T. specification, which may increase acoustic and power to operational levels.

2.2 Electromagnetic immunity

When properly installed in a representative host system, the drive operates without errors or degradation in performance when subjected to the radio frequency (RF) environments defined in the following table:

Table 4: Radio frequency environments

Test	Description	Performance level	Reference standard
Electrostatic discharge	Contact, HCP, VCP: ± 4 kV; Air: ± 8 kV	B	EN 61000-4-2: 95
Radiated RF immunity	80 to 1,000 MHz, 3 V/m, 80% AM with 1 kHz sine 900 MHz, 3 V/m, 50% pulse modulation @ 200 Hz	A	EN 61000-4-3: 96 ENV 50204: 95
Electrical fast transient	± 1 kV on AC mains, ± 0.5 kV on external I/O	B	EN 61000-4-4: 95
Surge immunity	± 1 kV differential, ± 2 kV common, AC mains	B	EN 61000-4-5: 95
Conducted RF immunity	150 kHz to 80 MHz, 3 Vrms, 80% AM with 1 kHz sine	A	EN 61000-4-6: 97
Voltage dips, interrupts	0% open, 5 seconds 0% short, 5 seconds 40%, 0.10 seconds 70%, 0.01 seconds	C C C B	EN 61000-4-11: 94

2.3 Reliability

Nonrecoverable read errors	1 per 10^{14} bits read, max.
Annualized Failure Rate (AFR)	0.68% (nominal power, 25°C ambient temperature)
Contact start-stop cycles	50,000 cycles (at nominal voltage and temperature, with 60 cycles per hour and a 50% duty cycle)
Warranty	5 years on distribution units. To determine the warranty for a specific drive, use a web browser to access the following web page: www.seagate.com/support/service/ From this page, click on the "Verify Your Warranty" link. You will be asked to provide the drive serial number, model number (or part number) and country of purchase. The system will display the warranty information for your drive.
Preventive maintenance	None required.

2.4 Agency certification

2.4.1 Safety certification

The drives are recognized in accordance with UL 1950 and CSA C22.2 (950) and meet all applicable sections of IEC950 and EN 60950 as tested by TUV North America.

2.4.2 Electromagnetic compatibility

Hard drives that display the CE mark comply with the European Union (EU) requirements specified in the Electromagnetic Compatibility Directive (89/336/EEC). Testing is performed to the levels specified by the product standards for Information Technology Equipment (ITE). Emission levels are defined by EN 55022, Class B and the immunity levels are defined by EN 55024.

Seagate uses an independent laboratory to confirm compliance with the EC directives specified in the previous paragraph. Drives are tested in representative end-user systems. Although CE-marked Seagate drives comply with the directives when used in the test systems, we cannot guarantee that all systems will comply with the directives. The drive is designed for operation inside a properly designed enclosure, with properly shielded I/O cable (if necessary) and terminators on all unused I/O ports. Computer manufacturers and system integrators should confirm EMC compliance and provide CE marking for their products.

Korean RRL

If these drives have the Korea Ministry of Information and Communication (MIC) logo, they comply with paragraph 1 of Article 11 of the Electromagnetic Compatibility control Regulation and meet the Electromagnetic Compatibility (EMC) Framework requirements of the Radio Research Laboratory (RRL) Ministry of Information and Communication Republic of Korea.

These drives have been tested and comply with the Electromagnetic Interference/Electromagnetic Susceptibility (EMI/EMS) for Class B products. Drives are tested in a representative, end-user system by a Korean-recognized lab.

- Family name: DB35 Series
- Certificate number: STX-L3510 (B)

Australian C-Tick (N176)

If these models have the C-Tick marking, they comply with the Australia/New Zealand Standard AS/NZS3548 1995 and meet the Electromagnetic Compatibility (EMC) Framework requirements of the Australian Communication Authority (ACA).

2.4.3 FCC verification

These drives are intended to be contained solely within a personal computer or similar enclosure (not attached as an external device). As such, each drive is considered to be a subassembly even when it is individually marketed to the customer. As a subassembly, no Federal Communications Commission verification or certification of the device is required.

Seagate Technology LLC has tested this device in enclosures as described above to ensure that the total assembly (enclosure, disc drive, motherboard, power supply, etc.) does comply with the limits for a Class B computing device, pursuant to Subpart J, Part 15 of the FCC rules. Operation with noncertified assemblies is likely to result in interference to radio and television reception.

Radio and television interference. This equipment generates and uses radio frequency energy and if not installed and used in strict accordance with the manufacturer's instructions, may cause interference to radio and television reception.

This equipment is designed to provide reasonable protection against such interference in a residential installation. However, there is no guarantee that interference will not occur in a particular installation. If this equipment does cause interference to radio or television, which can be determined by turning the equipment on and off, you are encouraged to try one or more of the following corrective measures:

- Reorient the receiving antenna.
- Move the device to one side or the other of the radio or TV.
- Move the device farther away from the radio or TV.
- Plug the computer into a different outlet so that the receiver and computer are on different branch outlets.

If necessary, you should consult your dealer or an experienced radio/television technician for additional suggestions. You may find helpful the following booklet prepared by the Federal Communications Commission: *How to Identify and Resolve Radio-Television Interference Problems*. This booklet is available from the Superintendent of Documents, U.S. Government Printing Office, Washington, DC 20402. Refer to publication number 004-000-00345-4.

2.5 Environmental protection

Seagate designs its products to meet environmental protection requirements worldwide, including regulations restricting certain chemical substances.

2.5.1 European Union Restriction of Hazardous Substances (RoHS) Directive

Seagate designs its products to meet environmental protection requirements worldwide, including regulations restricting certain chemical substances. A new law, the European Union Restriction of Hazardous Substances (RoHS) Directive, restricts the presence of chemical substances, including Lead, Cadmium, Mercury, Hexavalent Chromium, PBB and PBDE, in electronic products, effective July 2006. This drive is manufactured with components and materials that comply with the RoHS Directive.

2.5.2 China Restriction of Hazardous Substances (RoHS) Directive

2.5.2 中国限制危险物品的指令

This product has an Environmental Protection Use Period (EPUP) of 20 years. The following table contains information mandated by China's "Marking Requirements for Control of Pollution Caused by Electronic Information Products" Standard.



该产品具有20年的环境保护使用周期（EPUP）。下表包含了中国“电子产品所导致的污染的控制的记号要求”所指定的信息。

Name of Parts 部件名称	Toxic or Hazardous Substances or Elements 有毒有害物质或元素					
	Lead 铅 (Pb)	Mercury 汞 (Hg)	Cadmium 镉 (Cd)	Hexavalent Chromium 六价铬 (Cr6+)	Polybrominated Biphenyl 多溴联苯 (PBB)	Polybrominated Diphenyl Ether 多溴二苯醚 (PBDE)
PCBA	X	O	O	O	O	O
HDA	X	O	O	O	O	O

"O" indicates the hazardous and toxic substance content of the part (at the homogenous material level) is lower than the threshold defined by the China RoHS MCV Standard.

“O”表示该部件（于同类物品程度上）所含的危险和有毒物质低于中国RoHS MCV标准所定义的门槛值。

"X" indicates the hazardous and toxic substance content of the part (at the homogenous material level) is over the threshold defined by the China RoHS MCV Standard.

“X”表示该部件（于同类物品程度上）所含的危险和有毒物质超出中国RoHS MCV标准所定义的门槛值。

2.6 Corrosive environment

Seagate electronic drive components pass accelerated corrosion testing equivalent to 10 years exposure to light industrial environments containing sulfurous gases, chlorine and nitric oxide, classes G and H per ASTM B845. However, this accelerated testing cannot duplicate every potential application environment. Users should use caution exposing any electronic components to uncontrolled chemical pollutants and corrosive chemicals as electronic drive component reliability can be affected by the installation environment. The silver, copper, nickel and gold films used in Seagate products are especially sensitive to the presence of sulfide, chloride, and nitrate contaminants. Sulfur is found to be the most damaging. In addition, electronic components should never be exposed to condensing water on the surface of the printed circuit board assembly (PCBA) or exposed to an ambient relative humidity greater than 95%. Materials used in cabinet fabrication, such as vulcanized rubber, that can outgas corrosive compounds should be minimized or eliminated. The useful life of any electronic equipment may be extended by replacing materials near circuitry with sulfide-free alternatives.

3.0 Handling, mounting and configuring the drive

This section contains the specifications and instructions for configuring and mounting the drive.

3.1 Handling and static discharge precautions

After unpacking, and before installation, the drive may be exposed to potential handling and electrostatic discharge (ESD) hazards. Observe the following standard handling and static-discharge precautions:

Caution:

- Before handling the drive, put on a grounded wrist strap, or ground yourself frequently by touching the metal chassis of a computer that is plugged into a grounded outlet. Wear a grounded wrist strap throughout the entire installation procedure.
- Handle the drive by its edges or frame *only*.
- The drive is extremely fragile—handle it with care. Do not press down on the drive top cover.
- Always rest the drive on a padded, antistatic surface until you mount it in the computer.
- Do not touch the connector pins or the printed circuit board.
- Do not remove the factory-installed labels from the drive or cover them with additional labels. Removal voids the warranty. Some factory-installed labels contain information needed to service the drive. Other labels are used to seal out dirt and contamination.

3.2 Mounting the drive

You can mount the drive in any orientation using four screws in the side-mounting holes or four screws in the bottom-mounting holes. See Figure 3 for drive mounting dimensions. Follow these important mounting precautions when mounting the drive:

- Allow a minimum clearance of 0.030 inches (0.76 mm) around the entire perimeter of the drive for cooling.
- Use only 6-32 UNC mounting screws.
- Do not overtighten the mounting screws (maximum torque: 6 inch-lb.).
- Do not use a drive interface cable that is more than 18 inches long.

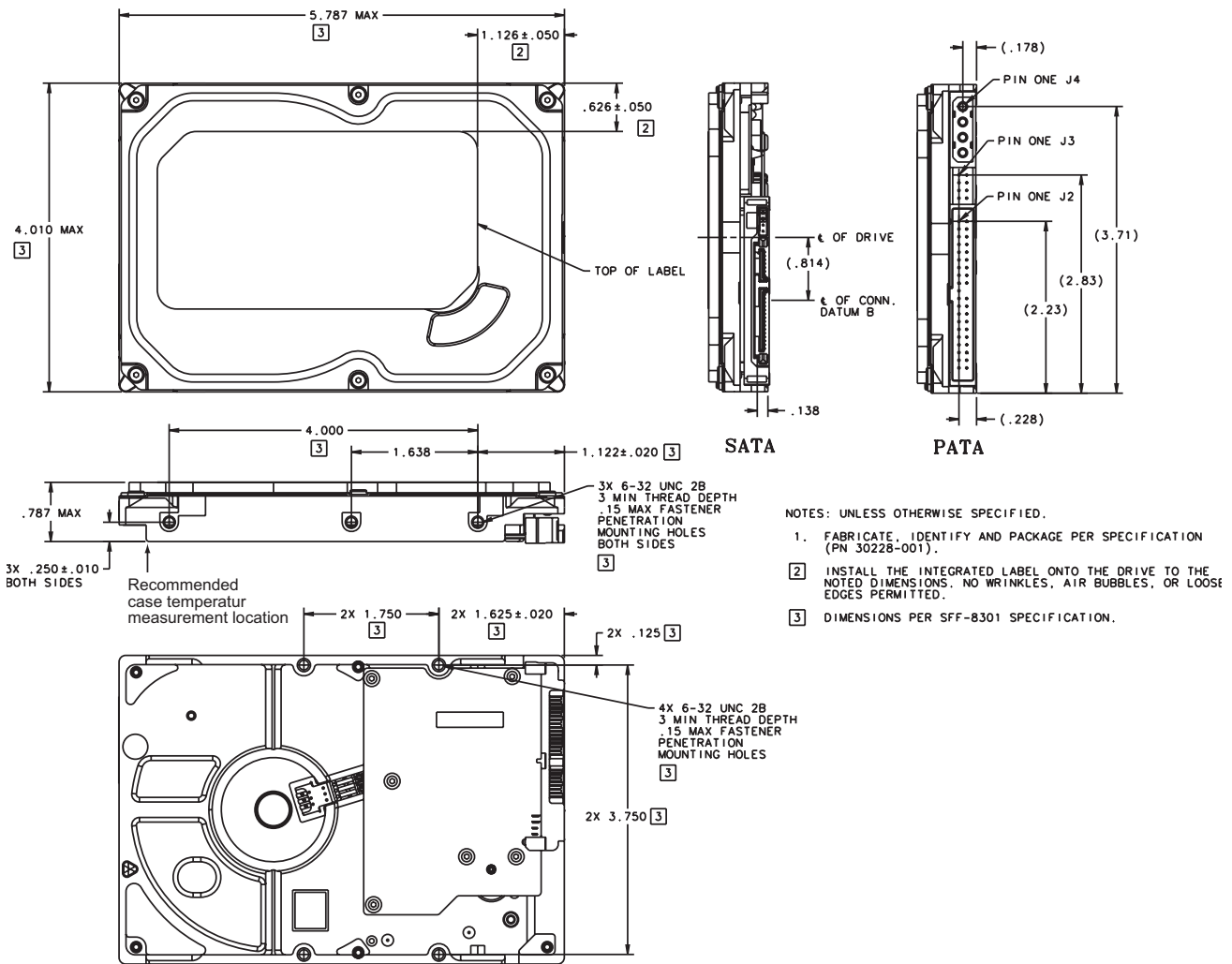

Figure 3 Mounting dimensions for PATA/SATA drives —top, side and end view

3.3 Breather filter hole precautions

This section contains information regarding the precautions which should be taken regarding the breather filter hole in Seagate hard disc drives. Proper precautions should be taken to ensure full functionality and prevent possible damage to the drive.

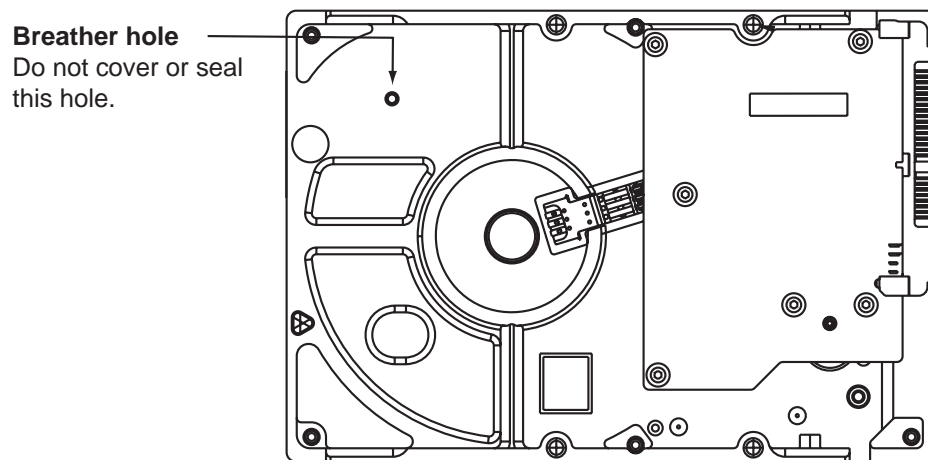

Figure 4 Breather filter hole location

Caution: Do not cover, seal, or insert any object into this hole.

This hole has two purposes:

- To allow condensation inside the hard disc to escape.
- To allow air pressure inside the hard disc to equalize with ambient pressure.
- If this hole is covered, sealed, or penetrated by any object, the drive reliability may be compromised and could lead to permanent damage. Covering or sealing this hole voids the warranty.

3.4 How to configure and attach Serial ATA (SATA) drives

3.4.1 How to configure the drive

Each drive on the Serial ATA interface connects point-to-point with the Serial ATA host adapter. There is no master/slave relationship because each drive is considered a master in a point-to-point relationship. If two drives are attached on one Serial ATA host adapter, the host operating system views the two devices as if they were both “masters” on two separate ports. Both drives behave as if they are Device 0 (master) devices.

Serial ATA drives are designed for easy installation. It is usually not necessary to set any jumpers on the drive for proper operation; however, if you connect the drive and receive a “drive not detected” error, your SATA-equipped motherboard or host adapter may use a chipset that does not support SATA speed autonegotiation. If you have a motherboard or host adapter that does not support autonegotiation:

- Install a jumper as shown in Figure 5 below to limit the data transfer rate to 1.5 Gbits per second (and leave the drive connected to the SATA-equipped motherboard or host adapter that doesn't support autonegotiation) or
- Install a SATA host adapter that supports autonegotiation, leave the drive jumper block set to “Normal operation” (see Figure 5 below), and connect the drive to that adapter. This option has the benefit of not limiting the drive to a 1.5 Gbits/sec transfer rate.

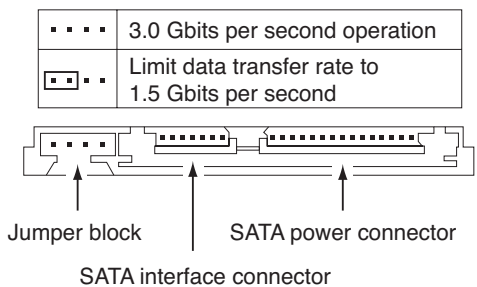

Figure 5. Serial ATA connectors

3.4.2 How to connect the SATA cables

The Serial ATA interface cable consists of four conductors in two differential pairs, plus three ground connections. The cable size may be 30 to 26 AWG with a maximum length of one meter (39.37 inches). See Table 5 for connector pin definitions. Either end of the SATA signal cable can be attached to the drive or host.

For direct backplane connection, the drive connectors are inserted directly into the host receptacle. The drive and the host receptacle incorporate features that enable the direct connection to be hot pluggable and blind mateable.

For installations which require cables, you can connect the drive as illustrated in Figure 6.

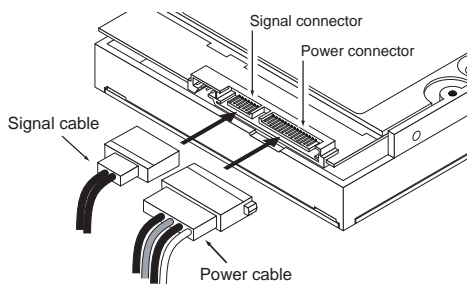

Figure 6. Attaching SATA cabling

Each cable is keyed to ensure correct orientation. DB35.3 Series drives support latching SATA connectors.

3.5 How to configure and attach the Parallel ATA (PATA) drives

3.5.1 How to set the jumper settings

The options jumper block shown in Figure 7 is used to configure the drive for operation. It is the 8-pin dual header between the interface connector and the power connector. Use the following settings to configure the drive as a master or a slave.

3.5.1.1 How to configure the drive as a master or slave

Master or single drive. The drive is configured at the factory for a master or single-drive operation with a jumper set on pins 7 and 8.

Drive as slave. Remove all jumpers.

Drive as master with a non-ATA-compatible slave.

Use this jumper setting *only* if the drive does not work as a master with no jumpers installed.

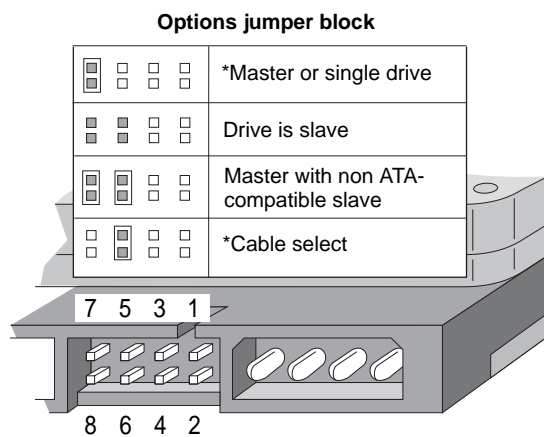

Figure 7 Master/slave jumper settings

3.5.1.2 How to use the cable-select option

Computers that use cable select determine the master and slave drives by selecting or deselecting pin 28, CSEL, on the interface bus. Master and slave drives are determined by their physical position on the cable. To enable cable select, set a jumper on pins 5 and 6 as shown in Figure 7. Refer to your computer manual to determine whether your computer supports this option.

3.5.1.3 Ultra ATA/100 cable

An 80-conductor 40-pin cable is required to run Ultra DMA mode 3, mode 4, and mode 5. This cable uses even-numbered conductors connected to the ground pins to improve signal integrity.

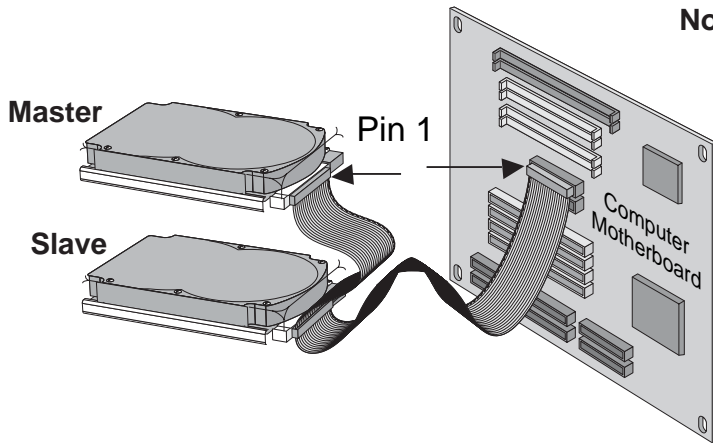

Note. If you are using a 40-pin, 80-conductor cable, attach the blue connector to the motherboard, the black connector to the master drive, and the gray connector to the slave.

Figure 8 Ultra ATA cable connectors

Note. The drive supports both host and drive cable detection. The host detects the 80-conductor cable by sampling pin 34, CBLID-, on the interface bus. The drive detects the 80-conductor cable by sensing a capacitor at the host side through the CBLID- signal. The result is reported in a Fast Rise Detected bit (bit 13 of word 93 in the Identify drive parameter block).

4.0 Interface

Interface	Refer to
SATA	Section 4.1 beginning on page 24
PATA	Section 4.2 beginning on page 26

The following sections apply to both SATA and PATA drives.

- Supported commands (see section 4.3 on page 27)
- Identify Device command (see section 4.4 on page 29)
- Set Features command (see section 4.5 on page 32)
- S.M.A.R.T. commands (see section 4.6 on page 33)

4.1 Serial ATA (SATA) interface

These drives use the industry-standard Serial ATA interface that supports FIS data transfers. It supports ATA programmed input/output (PIO) modes 0–4; multiword DMA modes 0–2, and Ultra DMA modes 0–6.

For detailed information about the Serial ATA interface, refer to the “Serial ATA: High Speed Serialized AT Attachment” specification.

4.1.1 Hot-Plug compatibility

DB35.3 Series drives incorporate connectors which enable you to hot plug these drives in accordance with the Serial ATA II: Extension to Serial ATA 1.0a specification. This specification can be downloaded from www.serialata.org.

4.1.2 Serial ATA device plug connector pin definitions

Table 5 summarizes the signals on the Serial ATA interface and power connectors.

Table 5: Serial ATA connector pin definitions

Segment	Pin	Function	Definition
Signal	S1	Ground	2nd mate
	S2	A+	Differential signal pair A from Phy
	S3	A-	
	S4	Ground	2nd mate
	S5	B-	Differential signal pair B from Phy
	S6	B+	
Signal	S7	Ground	2nd mate

Key and spacing separate signal and power segments

Power	P1	V ₃₃	3.3V power
	P2	V ₃₃	3.3V power
	P3	V ₃₃	3.3V power, pre-charge, 2nd mate
	P4	Ground	1st mate
	P5	Ground	2nd mate
	P6	Ground	2nd mate
	P7	V ₅	5V power, pre-charge, 2nd mate
	P8	V ₅	5V power
	P9	V ₅	5V power
	P10	Ground	2nd mate
	P11	Ground or LED signal	If grounded, drive does not use deferred spin
	P12	Ground	1st mate.
	P13	V ₁₂	12V power, pre-charge, 2nd mate
	P14	V ₁₂	12V power
	P15	V ₁₂	12V power

Notes:

1. All pins are in a single row, with a 1.27 mm (0.050") pitch.
2. The comments on the mating sequence apply to the case of backplane blindmate connector only. In this case, the mating sequences are:
 - the ground pins P4 and P12.
 - the pre-charge power pins and the other ground pins.
 - the signal pins and the rest of the power pins.
3. There are three power pins for each voltage. One pin from each voltage is used for pre-charge when installed in a blind-mate backplane configuration.
4. All used voltage pins (V_x) must be terminated.

4.2 Parallel ATA (PATA) Interface

These drives use the industry-standard ATA task file interface that supports 16-bit data transfers. It supports ATA programmed input/output (PIO) modes 0–4; multiword DMA modes 0–2, and Ultra DMA modes 0–5. The drive also supports the use of the IORDY signal to provide reliable high-speed data transfers.

You can use a daisy-chain cable to connect two drives to a single AT host bus. For detailed information about the ATA interface, refer to the draft of *AT Attachment with Packet Interface Extension (ATA/ATAPI-7)*, *NCITS T13 1410D*, subsequently referred to as the *Draft ATA-7 Standard*.

4.2.1 ATA interface signals and connector pins

Figure 9 on page 26 summarizes the signals on the ATA interface connector that the drive supports. For a detailed description of these signals, refer to the *Draft ATA-7 Standard*.

Drive pin #	Signal name	Host pin # and signal description
1	Reset	1 Hardware Reset
2	Ground	2 Ground
3	DD7	3 Host Data Bus Bit 7
4	DD8	4 Host Data Bus Bit 8
5	DD6	5 Host Data Bus Bit 6
6	DD9	6 Host Data Bus Bit 9
7	DD5	7 Host Data Bus Bit 5
8	DD10	8 Host Data Bus Bit 10
9	DD4	9 Host Data Bus Bit 4
10	DD11	10 Host Data Bus Bit 11
11	DD3	11 Host Data Bus Bit 3
12	DD12	12 Host Data Bus Bit 12
13	DD2	13 Host Data Bus Bit 2
14	DD13	14 Host Data Bus Bit 13
15	DD1	15 Host Data Bus Bit 1
16	DD14	16 Host Data Bus Bit 14
17	DD0	17 Host Data Bus Bit 0
18	DD15	18 Device Data (15:0)
19	Ground	19 Ground
20	(removed)	20 (No Pin)
21	DMARQ	21 DMA Request
22	Ground	22 Ground
23	DIOW	23 Device I/O Write:
	STOP	Stop Ultra DMA Burst
24	Ground	24 Ground
25	DIOR	25 Device I/O Read:
	HDMARDY	Host Ultra DMA Ready:
	HSTROBE	Host Ultra DMA Data Strobe
26	Ground	26 Ground
27	IORDY	27 I/O Channel Ready
	DDMARDY	Device Ultra DMA Ready
	DSTROBE	Device Ultra DMA Data Strobe
28	CSEL	28 Cable Select
29	DMACK	29 DMA Acknowledge
30	Ground	30 Ground
31	INTRQ	31 Device Interrupt
32	IOCS16	32 Reserved
33	DA1	33 Host Address Bus Bit 1
34	PDIAG	34 Passed Diagnostics
	CBLID	Cable Assembly Type Identifier
35	DA0	35 Device Address (2:0)
36	DA2	36 Device Address (2:0)
37	CS0	37 Chip Select (1:0)
38	CS1	38 Chip Select (1:0)
39	DASP	39 Drive Active/Slave Present
40	Ground	40 Ground

Pins 28, 34 and 39 are used for master-slave communication (details shown below).

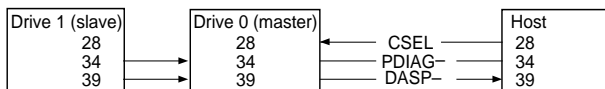

Figure 9 I/O pins and supported ATA signals

4.3 Supported ATA commands

The following table lists ATA-standard commands that the drive supports. For a detailed description of the ATA commands, refer to the Serial ATA: High Speed Serialized AT Attachment specification for SATA models or the *Draft ATA-7 Standard* for the PATA models. See “S.M.A.R.T. commands” on page 33 for details and subcommands used in the S.M.A.R.T. implementation.

Table 6: Supported ATA commands

Command name	Command code (in hex)
Check Power Mode	98 _H or E5 _H
Device Configuration Freeze Lock	B1 _H / C1 _H
Device Configuration Identify	B1 _H / C2 _H
Device Configuration Restore	B1 _H / C0 _H
Device Configuration Set	B1 _H / C3 _H
Device Reset	08 _H
Download Microcode	92 _H
Execute Device Diagnostics	90 _H
Flush Cache	E7 _H
Flush Cache Extended	EA _H
Format Track	50 _H
Identify Device	EC _H
Idle	97 _H or E3 _H
Idle Immediate	95 _H or E1 _H
Initialize Device Parameters	91 _H
Read Buffer	E4 _H
Read DMA	C8 _H
Read DMA Extended	25 _H
Read DMA Without Retries	C9 _H
Read Log Ext	2F _H
Read Multiple	C4 _H
Read Multiple Extended	29 _H
Read Native Max Address	F8 _H
Read Native Max Address Extended	27 _H
Read Sectors	20 _H
Read Sectors Extended	24 _H
Read Sectors Without Retries	21 _H
Read Verify Sectors	40 _H
Read Verify Sectors Extended	42 _H
Read Verify Sectors Without Retries	41 _H
Recalibrate	10 _H
Security Disable Password	F6 _H

Command name	Command code (in hex)
Security Erase Prepare	F3 _H
Security Erase Unit	F4 _H
Security Freeze	F5 _H
Security Set Password	F1 _H
Security Unlock	F2 _H
Seek	70 _H
Set Features	EF _H
Set Max Address Note: Individual Set Max Address commands are identified by the value placed in the Set Max Features register as defined to the right.	F9 _H Address: 00 _H Password: 01 _H Lock: 02 _H Unlock: 03 _H Freeze Lock: 04 _H
Set Max Address Extended	37 _H
Set Multiple Mode	C6 _H
Sleep	99 _H or E6 _H
S.M.A.R.T. Disable Operations	B0 _H / D9 _H
S.M.A.R.T. Enable/Disable Autosave	B0 _H / D2 _H
S.M.A.R.T. Enable Operations	B0 _H / D8 _H
S.M.A.R.T. Execute Offline	B0 _H / D4 _H
S.M.A.R.T. Read Attribute Thresholds	B0 _H / D1 _H
S.M.A.R.T. Read Data	B0 _H / D0 _H
S.M.A.R.T. Read Log Sector	B0 _H / D5 _H
S.M.A.R.T. Return Status	B0 _H / DA _H
S.M.A.R.T. Save Attribute Values	B0 _H / D3 _H
S.M.A.R.T. Write Log Sector	B0 _H / D6 _H
Standby	96 _H or E2 _H
Standby Immediate	94 _H or E0 _H
Write Buffer	E8 _H
Write DMA	CA _H
Write DMA Extended	35 _H
Write DMA FUA Extended	CD _H (SATA only)
Write DMA Without Retries	CB _H
Write Log Extended	3F _H
Write Multiple	C5 _H
Write Multiple Extended	39 _H
Write Multiple FUA Extended (SATA only)	CE _H (SATA only)
Write Sectors	30 _H
Write Sectors Without Retries	31 _H
Write Sectors Extended	34 _H

4.4 Identify Device command

The Identify Device command (command code EC_H) transfers information about the drive to the host following power up. The data is organized as a single 512-byte block of data, whose contents are shown in the Table 6 on page 27. All reserved bits or words should be set to zero. Parameters listed with an “x” are drive-specific or vary with the state of the drive. See Section 2.0 on page 3 for default parameter settings.

The following commands contain drive-specific features that may not be included in the Serial ATA specification for SATA models or *Draft ATA-7 Standard* for PATA models.

Word	Description	Value
0	Configuration information: <ul style="list-style-type: none"> • Bit 15: 0 = ATA; 1 = ATAPI • Bit 7: removable media • Bit 6: removable controller • Bit 0: reserved 	0C5A _H
1	Number of logical cylinders	16,383
2	ATA-reserved	0000 _H
3	Number of logical heads	16
4	Retired	0000 _H
5	Retired	0000 _H
6	Number of logical sectors per logical track: 63	003F _H
7–9	Retired	0000 _H
10–19	Serial number: (20 ASCII characters, 0000 _H = none)	ASCII
20	Retired	0000 _H
21	Retired	0400 _H
22	Obsolete	0000 _H
23–26	Firmware revision (8 ASCII character string, padded with blanks to end of string)	x.xx
27–46	Drive model number (40 ASCII characters, padded with blanks to end of string)	ST3xxxxxSCE - SATA models ST3xxxxxACE - PATA models
47	(Bits 7–0) Maximum sectors per interrupt on Read multiple and Write multiple (16)	8010 _H
48	Reserved	0000 _H
49	Standard Standby timer, IORDY supported and may be disabled	2F00 _H
50	ATA-reserved	0000 _H
51	PIO data-transfer cycle timing mode	0200 _H
52	Retired	0200 _H
53	Words 54–58, 64–70 and 88 are valid	0007 _H
54	Number of current logical cylinders	xxxx _H
55	Number of current logical heads	xxxx _H
56	Number of current logical sectors per logical track	xxxx _H
57–58	Current capacity in sectors	xxxx _H
59	Number of sectors transferred during a Read Multiple or Write Multiple command	xxxx _H

Word	Description	Value
60–61	Total number of user-addressable LBA sectors available (see Section 2.1.1 for related information) *Note: The maximum value allowed in this field is: 0FFFFFFFh (268,435,455 sectors, 137 Gbytes). Drives with capacities over 137 Gbytes will have 0FFFFFFFh in this field and the actual number of user-addressable LBAs specified in words 100-103. This is required for drives that support the 48-bit addressing feature.	0FFFFFFFh*
62	Retired	0000 _H
63	Multiword DMA active and modes supported (see note following this table)	xx07 _H
64	Advanced PIO modes supported (modes 3 and 4 supported)	0003 _H
65	Minimum multiword DMA transfer cycle time per word (120 nsec)	0078 _H
66	Recommended multiword DMA transfer cycle time per word (120 nsec)	0078 _H
67	Minimum PIO cycle time without IORDY flow control (240 nsec)	00F0 _H
68	Minimum PIO cycle time with IORDY flow control (120 nsec)	0078 _H
69–74	ATA-reserved	0000 _H
75	Queue depth	0000 _H
76	Serial ATA capabilities	xxxx _H (SATA only)
77	Reserved for future Serial ATA definition	xxxx _H (SATA only)
78	Serial ATA features supported	xxxx _H (SATA only)
79	Serial ATA features enabled	xxxx _H (SATA only)
80	Major version number	007E _H
81	Minor version number	0000 _H
82	Command sets supported	346B _H
83	Command sets supported	7D01 _H
84	Command sets support extension	4003 _H
85	Command sets enabled	34xx _H
86	Command sets enabled	3xxx _H
87	Command sets enable extension	4003 _H
88	Ultra DMA support and current mode (see note following this table)	xx3F _H
89	Security erase time	0000 _H
90	Enhanced security erase time	0000 _H
92	Master password revision code	FFFE _H
93	Hardware reset value (see description following this table)	xxxx _H
95–99	ATA-reserved	0000 _H
100–103	Total number of user-addressable LBA sectors available (see Section 2.1.1 for related information). These words are required for drives that support the 48-bit addressing feature. Maximum value: 0000FFFFFFFFFh.	160 GB models = 312,581,808 80 GB models = 156,301,488
104–127	ATA-reserved	0000 _H

Word	Description	Value
128	Security status	0001 _H
129–159	Seagate-reserved	xxxx _H
160–254	ATA-reserved	0000 _H
255	Integrity word	xxA5 _H

Note. Advanced Power Management (APM) and Automatic Acoustic Management (AAM) features are not supported

Note. See the bit descriptions below for words 63, 88, and 93 of the Identify Drive data:

Description (if bit is set to 1)		
Bit	Word 63	
0	Multiword DMA mode 0 is supported.	
1	Multiword DMA mode 1 is supported.	
2	Multiword DMA mode 2 is supported.	
8	Multiword DMA mode 0 is currently active.	
9	Multiword DMA mode 1 is currently active.	
10	Multiword DMA mode 2 is currently active.	
Bit	Word 88	
0	Ultra DMA mode 0 is supported.	
1	Ultra DMA mode 1 is supported.	
2	Ultra DMA mode 2 is supported.	
3	Ultra DMA mode 3 is supported.	
4	Ultra DMA mode 4 is supported.	
5	Ultra DMA mode 5 is supported.	
8	Ultra DMA mode 0 is currently active.	
9	Ultra DMA mode 1 is currently active.	
10	Ultra DMA mode 2 is currently active.	
11	Ultra DMA mode 3 is currently active.	
12	Ultra DMA mode 4 is currently active.	
13	Ultra DMA mode 5 is currently active.	
Bit	Word 93 (PATA only)	
13	1 = 80-conductor cable detected, CBLID above V _{IH} 0 = 40-conductor cable detected, CBLID below V _{IL}	

4.5 Set Features command

This command controls the implementation of various features that the drive supports. When the drive receives this command, it sets BSY, checks the contents of the Features register, clears BSY and generates an interrupt. If the value in the register does not represent a feature that the drive supports, the command is aborted. Power-on default has the read look-ahead and write caching features enabled. The acceptable values for the Features register are defined as follows:

02 _H	Enable write cache (<i>default</i>).
03 _H	Set transfer mode (based on value in Sector Count register). Sector Count register values:
00 _H	Set PIO mode to default (PIO mode 2).
01 _H	Set PIO mode to default and disable IORDY (PIO mode 2).
08 _H	PIO mode 0
09 _H	PIO mode 1
0A _H	PIO mode 2
0B _H	PIO mode 3
0C _H	PIO mode 4 (<i>default</i>)
20 _H	Multiword DMA mode 0
21 _H	Multiword DMA mode 1
22 _H	Multiword DMA mode 2
40 _H	Ultra DMA mode 0
41 _H	Ultra DMA mode 1
42 _H	Ultra DMA mode 2
43 _H	Ultra DMA mode 3
44 _H	Ultra DMA mode 4
45 _H	Ultra DMA mode 5
10 _H	Enable use of SATA features
55 _H	Disable read look-ahead (read cache) feature (SATA only)
82 _H	Disable write cache
90 _H	Disable use of SATA features (SATA only)
AA _H	Enable read look-ahead (read cache) feature (<i>default</i>).
F1 _H	Report full capacity available

Note. At power-on, or after a hardware or software reset, the default values of the features are as indicated above.

4.6 S.M.A.R.T. commands

S.M.A.R.T. provides near-term failure prediction for disc drives. When S.M.A.R.T. is enabled, the drive monitors predetermined drive attributes that are susceptible to degradation over time. If self-monitoring determines that a failure is likely, S.M.A.R.T. makes a status report available to the host. Not all failures are predictable. S.M.A.R.T. predictability is limited to the attributes the drive can monitor. For more information on S.M.A.R.T. commands and implementation, see the *Draft ATA-7 Standard*.

SeaTools diagnostic software activates a built-in drive self-test (DST S.M.A.R.T. command for D4_H) that eliminates unnecessary drive returns. The diagnostic software ships with all new drives and is also available at: <http://seatools.seagate.com>.

This drive is shipped with S.M.A.R.T. features disabled. You must have a recent BIOS or software package that supports S.M.A.R.T. to enable this feature. The table below shows the S.M.A.R.T. command codes that the drive uses.

Code in features register	S.M.A.R.T. command
D0 _H	S.M.A.R.T. Read Data
D2 _H	S.M.A.R.T. Enable/Disable Attribute Autosave
D3 _H	S.M.A.R.T. Save Attribute Values
D4 _H	S.M.A.R.T. Execute Off-line Immediate (runs DST)
D5 _H	S.M.A.R.T. Read Log Sector
D6 _H	S.M.A.R.T. Write Log Sector
D8 _H	S.M.A.R.T. Enable Operations
D9 _H	S.M.A.R.T. Disable Operations
DA _H	S.M.A.R.T. Return Status

Note. If an appropriate code is not written to the Features Register, the command is aborted and 0x04 (abort) is written to the Error register.

5.0 Seagate Technology support services

Internet

For information regarding Seagate products and services, visit www.seagate.com. Worldwide support is available 24 hours daily by email for your questions.

Presales Support:

Presales@Seagate.com

Technical Support:

DiscSupport@Seagate.com

Warranty Support:

<http://www.seagate.com/support/service/index.html>

mySeagate

my.seagate.com is the industry's first Web portal designed specifically for OEMs and distributors. It provides self-service access to critical applications, personalized content and the tools that allow our partners to manage their Seagate account functions. Submit pricing requests, orders and returns through a single, password-protected Web interface-anytime, anywhere in the world.

spp.seagate.com

spp.seagate.com supports Seagate resellers with product information, program benefits and sales tools. You may register for customized communications that are not available on the web. These communications contain product launch, EOL, pricing, promotions and other channel-related information. To learn more about the benefits or to register, go to spp.seagate.com, any time, from anywhere in the world.

Seagate Service Centers

Presales Support

Our Presales Support staff can help you determine which Seagate products are best suited for your specific application or computer system, as well as product availability and compatibility.

Technical Support

Seagate technical support is available to assist you online at support.seagate.com or through one of our call centers. Have your system configuration information and your "ST" model number available.

SeaTDD™ (+1-405-324-3655) is a telecommunications device for the deaf (TDD). You can send questions or comments 24 hours daily and exchange messages with a technical support specialist during normal business hours for the call center in your region.

Customer Service Operations

Warranty Service

Seagate offers worldwide customer support for Seagate products. Seagate distributors, OEMs and other direct customers should contact their Seagate Customer Service Operations (CSO) representative for warranty-related issues. Resellers or end users of drive products should contact their place of purchase or Seagate warranty service for assistance. Have your serial number and model or part number available.

Data Recovery Services

Seagate offers data recovery services for all formats and all brands of storage media. Our data recovery services labs are currently located throughout the world. . Additional information, including an online request form and data loss prevention resources, is available at <http://services.seagate.com/index.aspx>

Authorized Service Centers

Seagate Service Centers are available on a global basis for the return of defective products. Contact your customer support representative for the location nearest you.

USA/Canada/Latin America support services

For an extensive list of telephone numbers to technical support, presales and warranty service in USA/Canada/Latin America, including business hours, go to the "Contact Us" page on www.seagate.com.

Global Customer Support

Presales, Technical, and Warranty Support

Call Center	Toll-free	Direct dial
USA, Canada, and Mexico	1-800-SEAGATE	+1-405-324-4700

Data Recovery Services

Call Center	Toll-free	Direct dial	FAX
USA, Canada, and Mexico	1-800-475-01435	+1-905-474-2162	1-800-475-0158 +1-905-474-2459

Europe, the Middle East and Africa Support Services

For an extensive list of telephone numbers to technical support, presales and warranty service in Europe, the Middle East and Africa, go to the "Contact Us" page on www.seagate.com.

Asia/Pacific Support Services

For an extensive list of telephone numbers to technical support, presales and warranty service in Asia/Pacific, go to the "Contact Us" page on www.seagate.com.

Index

A

acoustics 12
Active mode 10
agency certification (regulatory) 14
altitude 11
ambient conditions 3
areal density 6
ATA-standard commands 27
Australian C-Tick 14
autodetection 1
average seek time 7

B

BPI 6
breather filter hole precautions 19
burst 1

C

cable 22
cable select 1
cables and connectors 20
cable-select option 21
cache 1
case temperature 11
CE mark 14
certification 14
Check Power Mode 27
China RoHS directive 16
commands 27
compliance 14
conducted noise 9
conducted RF immunity 13
configuring PATA drive 21
configuring SATA drive 20
configuring the drive 17
connector pins 26
connectors 22
contact start-stop cycles 13
Corrosive environment 16
CSA C22.2 (950) 14
CSEL 21
C-Tick 14
current profile 9
cycles 13

D

data-transfer rates 1
DC power 8
density 6
Device Configuration Freeze Lock 27

Device Configuration Identify 27
Device Configuration Restore 27
Device Configuration Set 27
Device Reset 27
diagnostic software 1, 33
dissipation 8
Download Microcode 27
drive diagnostics 7
drive monitoring 1
drive self-test 1, 33
DST 33

E

electrical fast transient 13
electromagnetic compatibility 14
Electromagnetic Compatibility Directive 14
electromagnetic immunity 13
electrostatic discharge 13
EMC compliance 14
EN 60950 14
enclosures 14
environmental specifications 11
EPRML 6
error-correction algorithms 1
errors 13
EU RoHS directive 16
European Union 14
Execute Device Diagnostics 27

F

failure prediction 33
FCC verification 14
features 1
Features register 32
Flush Cache 27
Flush Cache Extended 27
Format Track 27
formatted capacity 6
frequency 13

G

guaranteed sectors 6

H

handling 17
handling the drive 17
heads 1
height 7
humidity 11

I

I/O data-transfer rate 6
Identify Device 27

- Identify Device command 29
- Idle 27
- Idle and Standby timers 10
- Idle Immediate 27
- Idle mode 10
- Idle mode power 8
- IEC950 14
- Information Technology Equipment 14
- Initialize Device Parameters 27
- interface 6, 23
- interface signals 26
- interference 14
- internal data-transfer rate OD 6
- ISO document 7779 12

J

- jumper settings 21

K

- Korean RRL 14

L

- LBA mode 6
- length 7
- logical geometry 6

M

- maintenance 13
- master 21
- master/slave 1, 2
- Master/slave configuration 21
- maximum temperature 11
- measurement locations 11
- modes 26
- monitoring 1
- mounting the drive 17, 18

N

- noise 9
- nominal power 3
- nonoperating shock 11
- nonoperating vibration 12
- nonrecoverable read errors 13

O

- operating power and current 8
- operating shock 11
- operating vibration 12
- orientation 18

P

- PATA interface 26

- physical characteristics 7
- pins 26
- PIO 26
- point-to-point 2, 20
- power consumption 8
- power management 10
- power specifications 8
- power-management modes 10
- Power-on to Ready 7
- precautions 18
- preventive maintenance 13
- programmable power management 10

R

- radiated RF immunity 13
- radio and television interference 14
- radio frequency 13
- random track location 8
- Read Buffer 27
- Read DMA 27
- Read DMA Extended 27
- Read DMA without Retries 27
- read errors 13
- Read Log Ext 27
- Read Multiple 1, 27
- Read Multiple Extended 27
- Read Native Max Address 27
- Read Native Max Address Extended 27
- Read Sectors 27
- Read Sectors Extended 27
- Read Sectors Without Retries 27
- Read Verify Sectors 27
- Read Verify Sectors Extended 27
- Read Verify Sectors Without Retries 27
- read/write power and current 8
- Recalibrate 27
- recording and interface technology 6
- recording density 6
- recording heads 1
- recording method 6
- register 32
- relative humidity 11
- reliability 13
- resistance 9
- resistive load 9
- RF 13
- RoHS 16

S

- S.M.A.R.T. commands 33
- S.M.A.R.T. Disable Operations 28
- S.M.A.R.T. drive monitoring 1
- S.M.A.R.T. Enable Operations 28
- S.M.A.R.T. Enable/Disable Autosave 28

- S.M.A.R.T. Execute Offline 28
- S.M.A.R.T. Read Attribute Thresholds 28
- S.M.A.R.T. Read Data 28
- S.M.A.R.T. Read Log Sector 28
- S.M.A.R.T. Return Status 28
- S.M.A.R.T. Save Attribute Values 28
- S.M.A.R.T. Write Log sector 28
- safety certification 14
- SATA 24
- SATA interface 24
- screws 18
- SeaTools 1, 33
- sectors 6
- Security Disable Password 27
- Security Erase Prepare 28
- Security Erase Unit 28
- Security Freeze 28
- Security Set Password 28
- Security Unlock 28
- Seek 28
- seek mode 8
- seek temperature 7
- seek time 7
- serial ATA ports 2
- servo electronics 8
- Set Features 28
- Set Features command 32
- Set Max Address 28
- Set Max Address Extended 28
- Set Multiple Mode 28
- shock 11
- signals 26
- single-track seeks 7
- slave 21
- Sleep 8, 28
- Sleep mode 10
- sound 12
- specification summary table 3
- specifications 3
- spindle speed 6
- Spinup 8
- spinup power 8
- Standby 8, 28
- Standby Immediate 28
- Standby mode 8, 10
- Standby to Ready 7
- start/stop times 7
- start-stop cycles 13
- static-discharge precautions 17
- stop times 7
- subassembly 14
- support services 35
- surge immunity 13

T

- technical support services 35
- temperature 11
- temperature gradient 11
- timers 10
- TMR 1
- track density 6
- track-to-track seek time 7
- TUV North America 14

U

- UL 1950 14
- Ultra ATA/100 22
- Ultra DMA 22

V

- vibration 11
- voltage 9
- voltage dips, interrupts 13
- voltage tolerance 9

W

- weight 7
- wet bulb temperature 11
- width 7
- Write Buffer 28
- Write DMA 28
- Write DMA Extended 28
- Write DMA FUA Extended 28
- Write DMA Without Retries 28
- Write Log Extended 28
- Write Multiple 1, 28
- Write Multiple Extended 28
- Write Multiple FUA Extended 28
- Write Sectors 28
- Write Sectors Extended 28
- Write Sectors Without Retries 28



Seagate Technology LLC
920 Disc Drive, Scotts Valley, California 95066-4544, USA
Publication Number: 100439554, Rev. F, Printed in U.S.A.