



design • manufacture • supply

Midas Components Limited
Electra House
32 Southtown Road
Great Yarmouth
Norfolk
NR31 0DU
England

Telephone
Fax
Email
Website

+44 (0)1493 602602
+44 (0)1493 665111
sales@midasdisplays.com
www.midasdisplays.com

Specification	
Part Number:	MCOB22005A1V-EYP
Version:	
Date:	



design • manufacture • supply

- The following icons are absolutely designed by Midas independently in 2007-SEP. They are not in common use in the LCD industry yet but just used for marking out Midasproducts' characteristics quickly and simply without any special meaning. Midas reserves the composing right and copyright. No one else is allowed to adopt these icons without Midas approval.
- The ISO9001 logo used in this document is authorized by SGS (www.sgs.com). Midas had already successfully passed the strict and professional ISO9001:2000 Quality Management System Certification and got the certificate (No.: CN07/00404)
- The technologies/techniques/crafts which denoted by the following icons are not exclusively owned by Midas, but also shared by Midas LCD strategic cooperators, however all these technologies/techniques/crafts have been finally confirmed by Midas professional engineers and QC department.
- As the difference in test standard and test conditions, also Midas insufficient familiarity with the actual LCD using environment, all the referred information in this DATASHEET (including the icons) only have two functions:
 - 4.1: providing quick reference when you are judging whether or not the product meets your requirements.
 - 4.2: listing out definitely the tolerance.

SAMPLE APPROVAL document rather than consider this DATASHEET as the standard for judging whether or not the LCD meets your requirements. Once you instruct Midas to a mass-production without definite demand for providing sample before, Midas will disclaim all responsibility if the mass-production is proved not meeting with your requirements.

- The sequence of the icons is random and doesn't indicate the importance grade.
- Icons explanation

Midas 2006 version logo. Midas is an integrated manufacturer of flat panel display (FPD). Midas supplies TN, HTN, STN, FSTN monochrome LCD panel; COB, COG, TAB LCD module; and all kinds of LED backlight.



FAST RESPONSE TIME

This icon on the cover indicates the product is with high response speed; Otherwise not.



PROTECTION CIRCUIT

This icon on the cover indicates the product is with protection circuit; Otherwise not.



HIGH CONTRAST

This icon on the cover indicates the product is with high contrast; Otherwise not.



LONG LIFE VERSION

This icon on the cover indicates the product is long life version (over 9K hours guaranteed); Otherwise not.



WIDE VIEWING SCOPE

This icon on the cover indicates the product is with wide viewing scope; Otherwise not.



Anti UV VERSION

This icon on the cover indicates the product is against UV line. Otherwise not.



RoHS COMPLIANCE

This icon on the cover indicates the product meets ROHS requirements; Otherwise not.

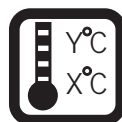

OPERATION TEMPERATURE RANGE

This icon on the cover indicates the operating temperature range (X-Y).



3TIMES 100% QC EXAMINATION

This icon on the cover indicates the product has passed Midas thrice 100% QC. Otherwise not.



TWICE SELECTION OF LED MATERIALS

This icon on the cover indicates the LED had passed Midas twice strict selection which promises the product's identical color and brightness; Otherwise not.



Vcm = 3.0V

This icon on the cover indicates the product can work at 3.0V exactly; otherwise not.



N SERIES TECHNOLOGY (2008 developed)

New structure, new craft, new technology and new materials inside both LCD module and LCD panel to improve the "RainBow"

Contents

Page

1.	Revision History	4
2.	General Specification	4
3.	Module Coding System	5
4.	Interface Pin Function	6
5.	Outline Dimension	7
6.	Optics & Electrical Characteristics	9
7..	Absolute Maximum Ratings	22
8.	Block Diagram	26
9.	Timing Characteristics	27
10.	Initializing of OLED Module	30
11	Absolute Maximum Ratings	47
12	Electrical Characteristicsical	48
13	Optical Characteristics	48
11.	OLED Lifetime	49
12.	Reliability	50
13.	Inspection specification	52
14	Precautions in use of Modules	58

1.Revision History

DATE	VERSION	REVISED PAGE NO.	Note
2010/12/07	1		First issue

2. General Specification

The Features is described as follow:

- Module dimension: 116.0 × 37.0 × 9.8 (max.) mm³
- View area: 85.0 × 18.6 mm²
- Active area: 77.3 × 11.85 mm²
- Number of dots: 20 Character x 2 Line
- Pixel size: 0.6 x 0.65 mm²
- Pixel pitch: 0.65 x0.70 mm2
- Character size: 3.2 x 5.55 mm2
- Character pitch: 3.9 x 6.25 mm2
- Duty: 1/16
- Emitting Color: Yellow

Midas Displays OLED Part Number System

MCO	B	21605	A	*	V	-	E	W	I	*
1	2	3	4	5	6		7	8	9	10
1	=	MCO:	Midas Displays OLED							
2	=	Blank:	B: COB (Chip on Board) T: TAB (Taped Automated Bonding)							
3	=	No of dots:	(e.g. 240064 = 240 x 64 dots)				(e.g. 21605 = 2 x 16 5mm C.H.)			
4	=	Series	A to Z							
5	=	Series Variant:	A to Z and 1 to 9 – see addendum							
6	=	Operating Temp Range:	A: -30+85° C		V: -40+80° C		Y: -40 +70° C		Z: -30+70° C	
			X: -40 +85° C							
7	=	Character Set:	Blank: Not Applicable E: Multi European Font Set (English/Japanese – Western European (K) – Cyrillic (R))							
8	=	Colour:	Y: Yellow		W: White		B: Blue		R: Red	
							G: Green		RGB: Full Colour	
9	=	Interface:	P: Parallel		I: I ² C		S: SPI		M: Multi	
10	=	Voltage Variant:	e.g. 3 = 3v							

4. Interface Pin Function

Pin No.	Symbol	Level	Description
1	VSS	0V	Ground
2	VDD	5.0V	Supply Voltage for logic
3	NC	—	
4	RS	H/L	H: DATA, L: Instruction code
5	R/W	H/L	H: Read(MPU→Module) L: Write(MPU→Module)
6	E	H,H→L	Chip enable signal
7	DB0	H/L	Data bit 0
8	DB1	H/L	Data bit 1
9	DB2	H/L	Data bit 2
10	DB3	H/L	Data bit 3
11	DB4	H/L	Data bit 4
12	DB5	H/L	Data bit 5
13	DB6	H/L	Data bit 6
14	DB7	H/L	Data bit 7
15	NC	—	
16	NC	—	

✘ Brightness Control

Brightness(nits)	Power consumption(measured with random texts)
125(typical)	80mW(5V*16mA)

Notes: 1. When random texts pattern is running , averagely , at any instance , about 1/2 of pixels will be

on.

2. You can to use the display off mode to make long life.

5. Outline Dimension

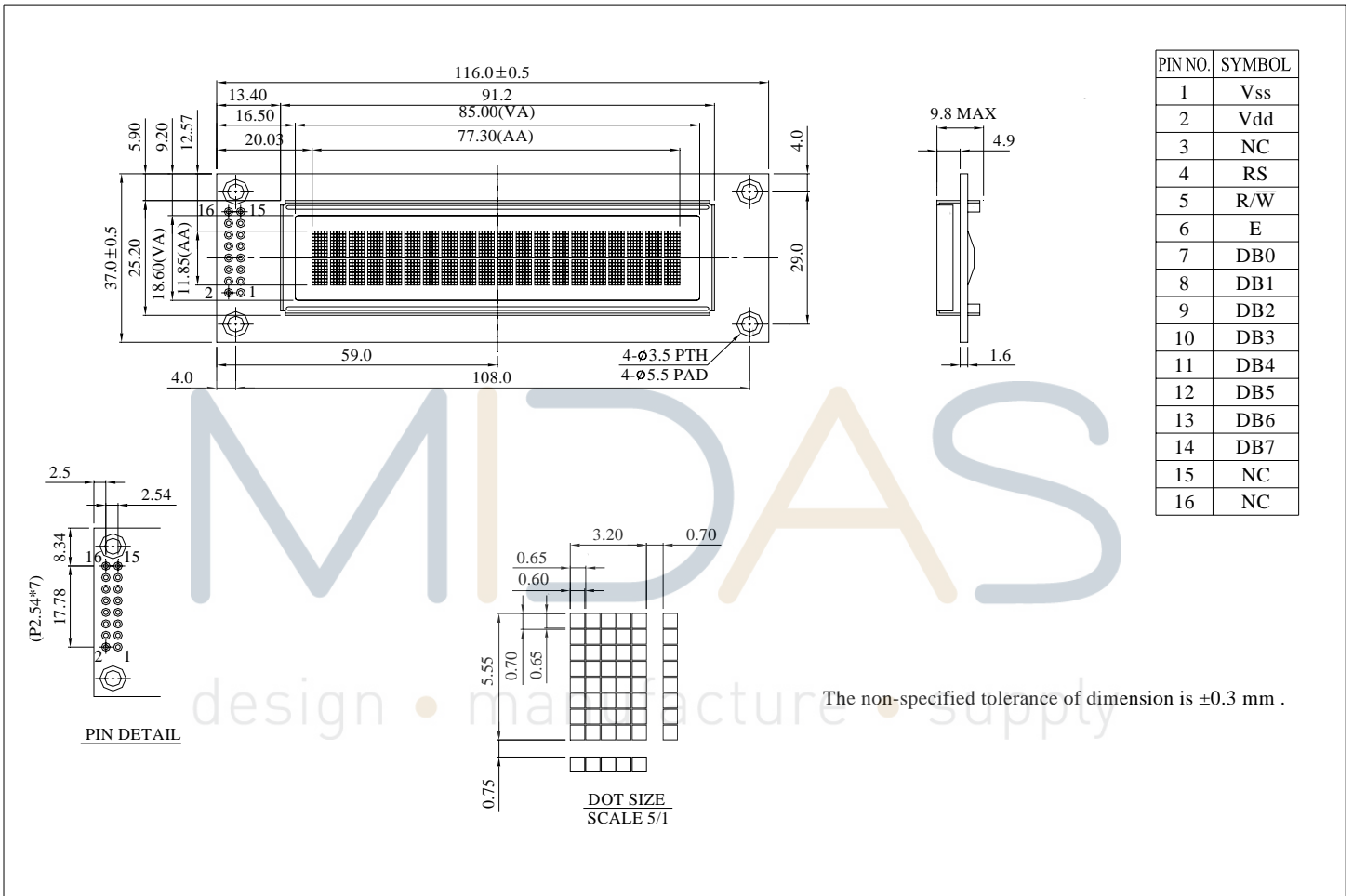

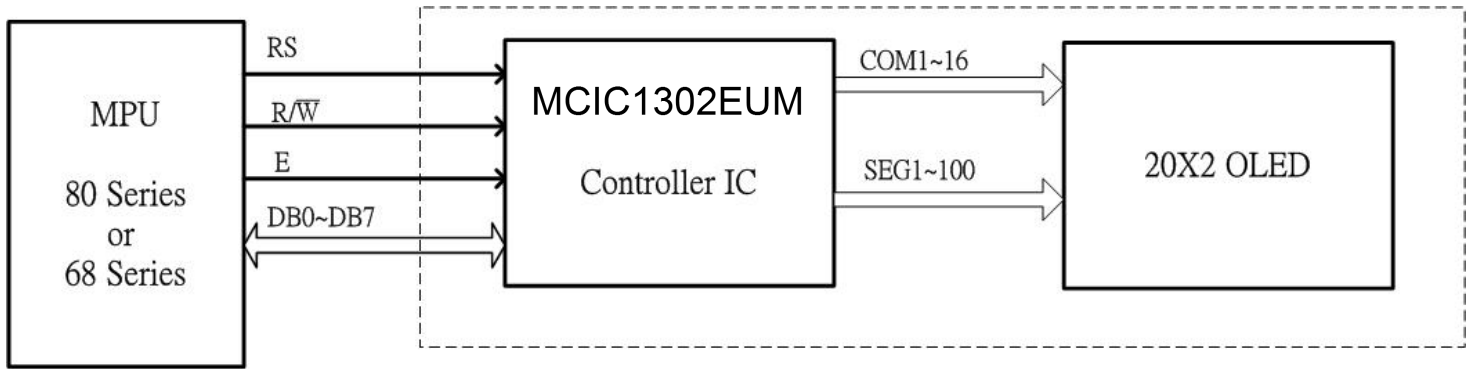

Address Format	DB7	DB6	DB5	DB4	DB3	DB2	DB1	DB0
CA (Character Address)	1	ADD6	ADD5	ADD4	ADD3	ADD2	ADD1	ADD0

1	2	3	4	17	18	19	20
CA1000000	CA1000001	CA1000010	CA1000011	CA1001000	CA1001001	CA1001010	CA1001011
CA1100000	CA1100001	CA1100010	CA1100011	CA1101000	CA1101001	CA1101010	CA1101011

6. Optics & Electrical Characteristics

REGISTERS

IC provides two types of 8-bit registers, namely: Instruction Register (IR) and Data Register (DR). The register is selected using the RS Pin. When the RS pin is set to "0", the Instruction Register Type is selected. When RS pin is set to "1", the Data Register Type is selected. Please refer to the table below.

RS	R/WB	Operation
0	0	Instruction register write as an internal operation.
0	1	Read busy flag (DB7) and address counter (DB0 to DB6)
1	0	Data register write as an internal operation (DR to DDRAM or CGRAM)
1	1	Data register read as an internal operation (DDRAM or CGRAM to DR)

INSTRUCTION REGISTER (IR)

The Instruction Register is used to store the instruction code (i.e. Display Clear, Cursor Home and others), Display Data RAM (DDRAM) Address, and the Character Generator RAM (CGRAM) Address. Instruction register can only be written from the MPU.

DATA REGISTER (DR)

The Data Register is used as a temporary storage for data that are going to be written into the DDRAM or CGRAM as well as those data that are going to be read from the DDRAM or CGRAM.

BUSY FLAG (BF)

The Busy Flag is used to determine whether IC is idle or internally operating. When IC is performing some internal operations, the Busy Flag is set to "1". Under this condition, the no other instruction will not be accepted. When RS Pin is set to "0" and R/WB Pin is set to "1", the Busy Flag will be outputted to the DB7 pin.

When IC is idle or has completed its previous internal operation, the Busy Flag is set to "0". The next instruction can now be processed or executed.

ADDRESS COUNTER (AC)

The address counter is used to assign the Display Data RAM (DDRAM) Address and the Character Generator RAM (CGRAM) Address. When Address information is written into the Instruction Register (IR), this Address information is sent from the Instruction Register to the Address Counter. At the same time, the nature of the Address (either CGRAM or DDRAM) is determined by the instruction.

After writing into or reading from the DDRAM or CGRAM, the Address Counter is automatically increased or decreased by 1 (for Write or Read Function). It must be noted that when the RS pin is set to "0" and R/WB is set to "1", the contents of the Address Counter are outputted to the pins – DB0 to

DB6.

DISPLAY DATA RAM (DDRAM)

The Display Data RAM (DDRAM) is used to store the Display Data which is represented as 8-bit character code. The Display Data RAM supports an extended capacity of 128 x8-bits or 128 characters.

The Display Data RAM Address (ADD) is set in the Address Counter as a hexadecimal.

	High Order Bits			Low Order Bits			
Address Counter (hex)	AC6	AC5	AC4	AC3	AC2	AC1	AC0

An example of a DDRAM Address=39 is given below.

DDRAM Address:39						
AC6	AC5	AC4	AC3	AC2	AC1	AC0
0	1	1	1	0	0	1

1-LINE DISPLAY (N=0)

When the number of characters displayed is less than 128, the first character is displayed at the head position. The relationship between the DDRAM Address and position on the OLED Panel is shown below.

Display Position (digit)	1	2	3	4	126	127	128
DDRAM address (hexadecimal)	00	01	02	03	7D	7E	7F

For example, when only 8 characters are displayed in one Display Line, the relationship between the DDRAM Address and position on the OLED Panel is shown below.

Display Position	1	2	3	4	5	6	7	8
DDRAM address	00	01	02	03	04	05	06	07
Shift left	01	02	03	04	05	06	07	08
Shift right	7F	00	01	02	03	04	05	06

2-LINE DISPLAY (N=1)

Case 1: The Number of Characters displayed is less than 64 x 2 lines

When the number of characters displayed is less than 64 x 2 lines, then the first character of the first and second lines are displayed starting from the head. It is important to note that every line reserve 64 x 8bits DDRAM space. 1st line is 00 to 3F, second line is 40 to 7F. Please refer the figure below.

Display Position	1	2	3	4	61	62	63	64
DDRAM Address (hexadecimal)	00	01	02	03	3C	3D	3E	3F
	40	41	42	43	7C	7D	7E	7F

To illustrate, for 2-line x 20 characters display, the relationship between the DDRAM address and position of the OLED panel is shown below.

Display Position	1	2	3	4	18	19	20
DDRAM address (hexadecimal)	00	01	02	03	11	12	13
	40	41	42	43	51	52	53
Shift left	01	02	03	04	19	20	21
	41	42	43	44	52	53	54
Shift right	3F	00	01	02	10	11	12
	7F	40	41	42	50	51	52

Case 2: 40-Character x 2 Lines Display

IC(Master) can be extended to display 40 characters x 2 lines by cascade the other IC(Slave). When there is a Display Shift operation, the DDRAM Address is also shifted. Please refer to the example below.

Display Position	1	2	3	4	5	6	7	8	9	10	11	37	38	39	40
DDRAM address	00	01	02	03	04	05	06	07	08	09	0A	24	25	26	27
	40	41	42	43	44	45	46	47	48	49	4A	64	65	66	67
	IC display (Master)											Cascade 2 nd IC (Slave)				
Shift left	01	02	03	04	05	06	07	08	09	0A	0B	25	26	27	28
	41	42	43	44	45	46	47	48	49	4A	4B	65	66	67	68
Shift right	3F	00	01	02	03	04	05	06	07	08	09	23	24	25	26
	7F	40	41	42	43	44	45	46	47	48	49	63	64	65	66

SLAVE MODE DATA INPUT

When IC is under slave mode, display data is send from the other IC(master).The input data "D" is shifted at the falling edge of CL

M/S	Mode	D	CL	LAT
H	Master	Output	Output	Output
L	Slave	Input	Input	Input

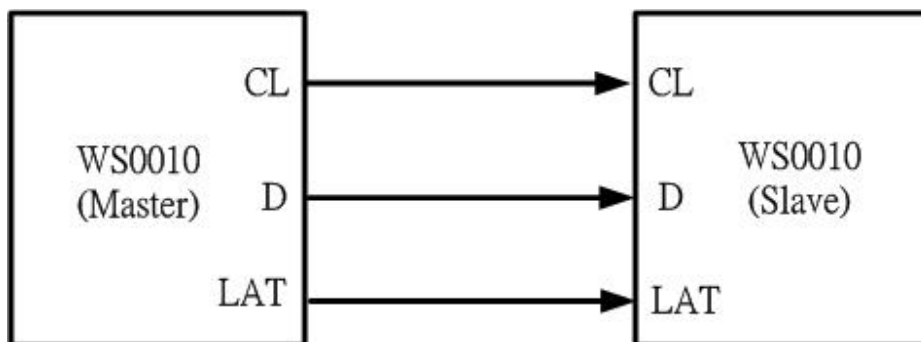

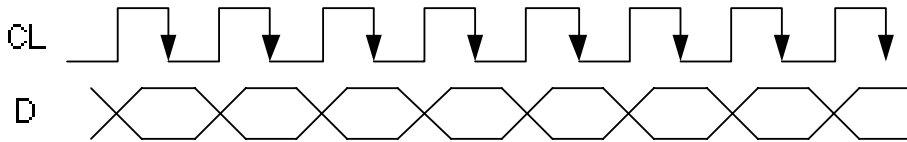

BIDIRECTIONAL SHIFT REGISTER BLOCK

This block shifts the serial data at the falling edge of CL. When SHL is set "H", the data input from D is shifted from bit100 to bit1 (When IC is "master" mode, D is output; When IC is "slave" mode, D is input). When SHL is set "L", the data input is shifted from bit1 to bit100.

Condition 1 : SHL="H"

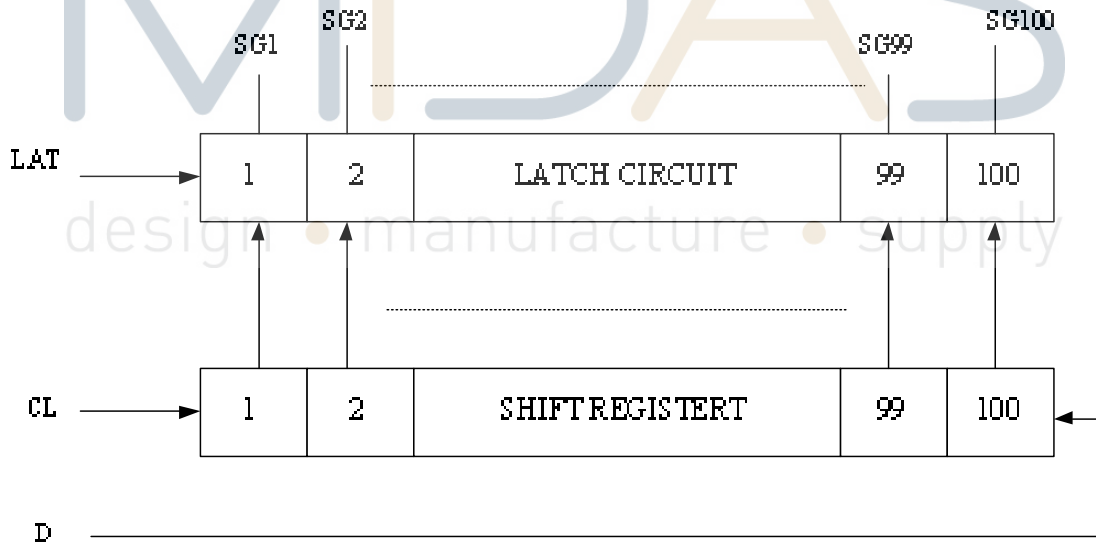

Condition 2 : SHL="L

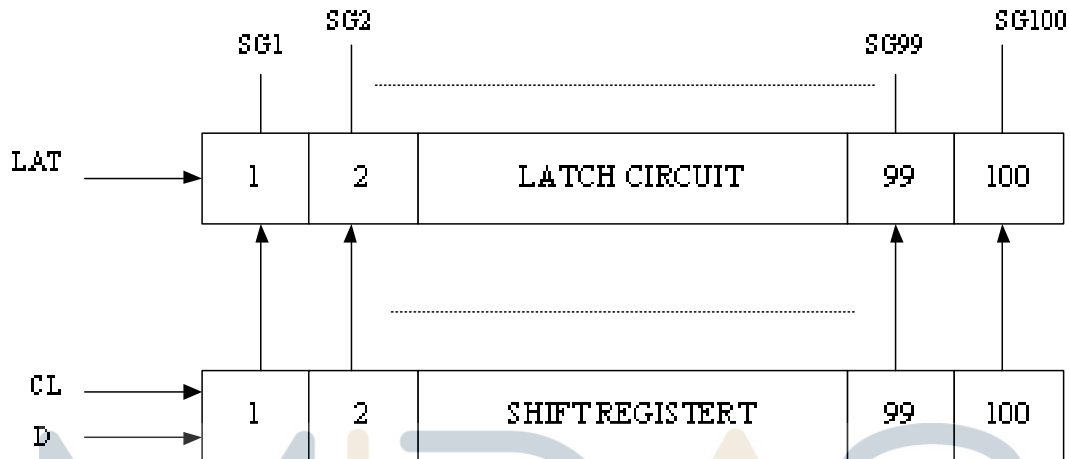

CHARACTER GENERATOR ROM (CGROM)

The Character Generator ROM (CGROM) is used to generate either 5 x 8 dots or 5 x 10 dots character patterns from 8-bit character codes. IC build in three set of font tables as "Western European", "English Japanese" and "English Russian". User can use software to select suitable font table (**Default "English Japanese"**).

CHARACTER GENERATOR RAM (CGRAM)

The Character Generator RAM (CGRAM) is used to generate either 5 x 8 dot or 5 x 10 dot character patterns. It can generate eight 5 x 8 dot character patterns or four 5 x 10 dot character patterns. The character patterns generated by the CGRAM can be rewritten. User-defined character patterns for the CGRAM are supported.

RELATIONSHIP BETWEEN CGRAM ADDRESS, DDRAM CHARACTER CODE AND CGRAM CHARACTER PATTERNS (FOR 5 X 8 DOT CHARACTER PATTERN)

Character Codes (DDRAM Data)								CGRAM Address						Character Patterns (CGRAM Data)								
7	6	5	4	3	2	1	0	5	4	3	2	1	0	7	6	5	4	3	2	1	0	
High				Low				High			Low			High				Low				
0	0	0	0	*	0	0	0	0	0	0	0	0	0	*	*	*	1	1	1	1	0	Character pattern 1
											0	0	1	*	*	*	1	0	0	0	1	
											0	1	0	*	*	*	1	0	0	0	1	
											0	1	1	*	*	*	1	1	1	1	0	
											1	0	0	*	*	*	1	0	1	0	0	
											1	0	1	*	*	*	1	0	0	1	0	
											1	1	0	*	*	*	1	0	0	0	1	
											1	1	1	*	*	*	0	0	0	0	0	
0	0	0	0	*	0	0	1	0	0	1	0	0	0	*	*	*	1	0	0	0	1	Character pattern 2
											0	0	1	*	*	*	0	1	0	1	0	
											0	1	0	*	*	*	1	1	1	1	1	
											0	1	1	*	*	*	0	0	1	0	0	
											1	0	0	*	*	*	1	1	1	1	1	
											1	0	1	*	*	*	0	0	1	0	0	
											1	1	0	*	*	*	0	0	1	0	0	
											1	1	1	*	*	*	0	0	0	0	0	
0	0	0	0	*	0	0	0	*	*	*	0	0	0	0	0	Character pattern 3~7
											0	0	1	*	*	*	0	1	0	1	0	
											0	1	0	*	*	*	0	0	0	0	0	
											0	1	1	*	*	*	0	0	0	0	0	
											1	0	0	*	*	*	1	0	0	0	1	
											1	0	1	*	*	*	0	1	1	1	0	
											1	1	0	*	*	*	0	0	1	0	0	
											1	1	1	*	*	*	0	0	0	0	0	
0	0	0	0	*	1	1	1	1	1	1	0	0	0	*	*	*	0	0	0	0	0	Character pattern 8
											0	0	1	*	*	*	0	1	0	1	0	
											0	1	0	*	*	*	0	0	0	0	0	
											0	1	1	*	*	*	0	0	0	0	0	
											1	0	0	*	*	*	1	0	0	0	1	
											1	0	1	*	*	*	0	1	1	1	0	
											1	1	0	*	*	*	0	0	1	0	0	
											1	1	1	*	*	*	0	0	0	0	0	
											Cursor position											

Notes:

1. * = Not Relevant

2. The character pattern row positions correspond to the CGRAM data bits -- 0 to 4, where bit 4 is in the left position.

3. Character Code Bits 0 to 2 correspond to the CGRAM Address Bits 3 to 5 (3 bits: 8 types)

4. If the CGRAM Data is set to "1", then the selection is displayed. If the CGRAM is set to "0", there no selection is made.

5. The CGRAM Address Bits 0 to 2 are used to define the character pattern line position. The 8th line is the cursor position and its display is formed by the logical OR with the cursor. The 8th line CGRAM data bits 0 to 4 must be set to "0". If any of the 8th line CGRAM data bits 0 to 4 is set to "1", the corresponding display location will light up regardless of the cursor position.

6. When the Character Code Bits 4 to 7 are set to "0", then the CGRAM Character Pattern is selected. It must be noted that Character Code Bit 3 is not relevant and will not have any effect on the character display. Because of this, the first Character Pattern shown above (R) can be displayed when the Character Code is 00H or 08H.

The logo for MIDAS features the word "MIDAS" in a large, sans-serif font. The letters "M", "I", "D", and "S" are rendered in a light blue color, while the letters "A" and "S" are rendered in a light orange color. The letters are closely spaced and have a slight shadow effect.

design • manufacture • supply

RELATIONSHIP BETWEEN CGRAM ADDRESS, DDRAM CHARACTER CODE AND CGRAM CHARACTER PATTERNS (FOR 5 X10 DOT CHARACTER PATTERN)

Character Codes (DDRAM Data)								CGRAM Address						Character Patterns (CGRAM Data)								
7	6	5	4	3	2	1	0	5	4	3	2	1	0	7	6	5	4	3	2	1	0	
High				Low				High			Low			High				Low				
0	0	0	0	*	0	0	*	0	0	0	0	0	0	*	*	*	0	0	1	0	0	Character pattern 1
										0	0	0	1	*	*	*	0	1	1	1	0	
										0	0	1	0	*	*	*	1	0	1	0	1	
										0	0	1	1	*	*	*	1	0	1	0	0	
										0	1	0	0	*	*	*	0	1	1	0	0	
										0	1	0	1	*	*	*	0	0	1	1	0	
										0	1	1	0	*	*	*	0	0	1	0	1	
										0	1	1	1	*	*	*	1	0	1	0	1	
										1	0	0	0	*	*	*	0	1	1	1	0	
										1	0	0	1	*	*	*	0	0	1	0	0	
										1	0	1	0	*	*	*	*	*	*	*	*	
										1	0	1	1	*	*	*	*	*	*	*	*	
0	0	0	0	*	.	.	*	.	.	0	0	0	0	Character pattern 2~3	
										0	0	1	0
										0	0	1	1
										0	1	0	0
										0	1	0	1
										0	1	1	0
										0	1	1	1
										1	0	0	0
0	0	0	0	*	1	1	*	1	1	0	0	0	0	*	*	*	1	0	1	0	1	Character pattern 4
										0	0	0	1	*	*	*	1	1	1	1	1	
										0	0	1	0	*	*	*	1	1	1	1	1	
										0	0	1	1	*	*	*	1	1	1	1	1	
										0	1	0	0	*	*	*	0	1	1	1	0	
										0	1	0	1	*	*	*	0	0	1	0	0	
										0	1	1	0	*	*	*	0	0	1	0	0	
										0	1	1	1	*	*	*	1	0	1	0	1	
										1	0	0	0	*	*	*	0	1	1	1	0	
										1	0	0	1	*	*	*	0	0	1	0	0	
										1	0	1	0	*	*	*	*	*	*	*	*	
										1	0	1	1	*	*	*	*	*	*	*	*	
0	0	0	0	*	1	1	*	1	1	0	0	0	0	Character pattern 4	
										0	0	1	0
										0	0	1	1
										0	1	0	0
										0	1	0	1
										0	1	1	0
										0	1	1	1
										1	0	0	0
0	0	0	0	*	1	1	*	1	1	0	0	0	0	Character pattern 4	
										0	0	1	0
										0	0	1	1
										0	1	0	0
										0	1	0	1
										0	1	1	0
										0	1	1	1
										1	0	0	0
0	0	0	0	*	1	1	*	1	1	0	0	0	0	Character pattern 4	
										0	0	1	0
										0	0	1	1
										0	1	0	0
										0	1	0	1
										0	1	1	0
										0	1	1	1
										1	0	0	0
0	0	0	0	*	1	1	*	1	1	0	0	0	0	Character pattern 4	
										0	0	1	0
										0	0	1	1
										0	1	0	0
										0	1	0	1
										0	1	1	0
										0	1	1	1
										1	0	0	0
0	0	0	0	*	1	1	*	1	1	0	0	0	0	Character pattern 4	
										0	0	1	0
										0	0	1	1
										0	1	0	0
										0	1	0	1
										0	1	1	0
										0	1	1	1
										1	0	0	0
0	0	0	0	*	1	1	*	1	1	0	0	0	0	Character pattern 4	
										0	0	1	0
										0	0	1	1
										0	1	0	0
										0	1	0	1
										0	1	1	0
										0	1	1	1
										1	0	0	0

Notes:

1. * = Not Relevant
2. The character pattern row positions correspond to the CGRAM data bits -- 0 to 4, where bit 4 is in the left position.
3. Character Code Bits 1 and 2 correspond to the CGRAM Address Bits – 4 and 5 respectively (2 bits : 4 types)
4. If the CGRAM Data is set to "1", then the selection is displayed. If the CGRAM is set to "0", there no selection is made.
5. The CGRAM Address Bits 0 to 3 are used to define the character pattern line position. The 11th line is the cursor position and its display is formed by the logical OR with the cursor. The 11th line CGRAM data bits 0 to 4 must be set to "0". If any of the 11th line CGRAM data bits 0 to 4 is set to "1", the corresponding display location will light up regardless of the cursor position.
6. When the Character Code Bits 4 to 7 are set to "0", then the CGRAM Character Pattern is selected. It must be noted that Character Code Bit -- 0 and 3 are not relevant and will not have any effect on the character display. Because of this, the Character Pattern shown above (\$) can be displayed when the Character Code is 00H, 01H, 08H or 09H.

TIMING GENERATION CIRCUIT

The timing signals for the internal circuit operations (i.e. DDRAM, CGRAM, and CGROM) are generated by the Timing Generation Circuit. The timing signals for the MPU internal operation and the RAM Read for Display are generated separately in order to prevent one from interfering with the other. This means that, for example, when the data is being written into the DDRAM, there will be no unwanted interference such as flickering in areas other than the display area.

OLED DRIVER CIRCUIT

IC provides 16 Common Drivers and 100 Segment Driver Outputs. When a character font and the number of lines to be displayed have been selected, the corresponding Common Drivers output the waveform automatically. A non-selection waveform will be outputted by the rest of the Common outputs.

CURSOR/BLINK CONTROL CIRCUIT

The cursor or character blinking is generated by the Cursor / Blink Control Circuit. The cursor or the blinking will appear with the digit located at the Display Data RAM (DDRAM) Address Set in the Address Counter (AC).

	AC6	AC5	AC4	AC3	AC2	AC1	AC0
Address counter	0	0	0	0	1	1	1

CASE 1: FOR 1-LINE DISPLAY

Example: When the Address Counter (AC) is set to 0EH, the cursor position is displayed at DDRAM Address 0EH.

Display position	1	2	3	4	5	14	15	19	20
DDRAM address (hexadecimal)	00	01	02	03	04	0D	0E	12	13

|
Cursor Position

Notes:

The cursor or blinking appears when the Address Counter (AC) selects the Character Generator RAM (CGRAM). When the AC selects CGRAM Address, then the cursor or the blinking is displayed in a irrelevant and meaningless position.

CASE 2: FOR 2-LINE DISPLAY

Example: When the Address Counter (AC) is set to 46H, the cursor position is displayed at DDRAM Address 46H.

Display position	1	2	3	4	5	6	7	8	19	20
DDRAM address (hexadecimal)	00	01	02	03	04	05	06	07	09	13
	40	41	42	43	44	45	46	47	49	53

design • manufacture • supply

Cursor Position

Notes:

The cursor or blinking appears when the Address Counter (AC) selects the Character Generator RAM (CGRAM). When the AC selects CGRAM Address, then the cursor or the blinking is displayed in an irrelevant and meaningless position.

CHARACTER MODE ADDRESSING

IC provides two kind of character mode. User can fill in 128 characters data (N=0, one line) or 64 characters data per line (N=1, two line) in embedded RAM to display graphic. Character mode address can be controlled by DDRAM address instruction.

Address Form at	DB7	DB6	DB5	DB4	DB3	DB2	DB1	DB0
CA (Character Address)	1	ADD6	ADD5	ADD4	ADD3	ADD2	ADD1	ADD0

(1) 1-Line condition (N=0)

1	2	3	4	125	126	127	128
CA=10000000	CA=10000001	CA=10000010	CA=10000011			CA=11111100	CA=11111101	CA=11111110	CA=11111111

(2) 2-Line condition (N=1)

1	2	3	4	61	62	63	64
CA=10000000	CA=10000001	CA=10000010	CA=10000011			CA=10111100	CA=10111101	CA=10111110	CA=10111111
CA=11000000	CA=11000001	CA=11000010	CA=11000011			CA=11111100	CA=11111101	CA=11111110	CA=11111111

GRAPHIC MODE ADDRESSING

IC provides not only character mode but also graphic mode. User can fill in 100x16 data in embedded RAM to display graphic. Graphic mode addressing is different from character mode.

Use DDRAM address instruction to set X-axis address of Graphic mode and CGRAM address instruction to set Y-axis of Graphic mode.

Address Form at	DB7	DB6	DB5	DB4	DB3	DB2	DB1	DB0
GXA(Graphic X-axis Address)	1	ADD6	ADD5	ADD4	ADD3	ADD2	ADD1	ADD0
GYA(Graphic Y-axis Address)	0	1	0	0	0	0	0	CGA0

	1	2	3	4	97	98	99	100
CGA0=0	GXA=1000000 GYA=0100000	GXA=1000001 GYA=0100000	GXA=1000010 GYA=0100000	GXA=1000011 GYA=0100000	D0		GXA=1110000 GYA=0100000	GXA=1110001 GYA=0100000	GXA=1110010 GYA=0100000	GXA=1110011 GYA=0100000
					D1					
					D2					
					D3					
					D4					
					D5					
					D6					
					D7					
C		X	X	X			X	X	X	X

design • manufacture • supply

7. Absolute Maximum Ratings

CHARACTER GENERATOR ROM (CGROM)

IC provides three set of character font. Character font can be selected by programming FT.

ENGLISH JAPANESE CHARACTER FONT TABLE (default FT[1:0]= 00)

Upper 4bit Lower 4bit	LLLL	LLLH	LLHL	LLHH	LHLL	LHLH	LHHL	LHHH	HLLL	HLLH	HLHL	HLHH	HHLL	HHLH	HHHL	HHHH
LLLL	CG RAM (1)	☒	☒	☒	☒	☒	☒	☒	☒	☒	☒	☒	☒	☒	☒	☒
LLLL	CG RAM (2)	☒	☒	☒	☒	☒	☒	☒	☒	☒	☒	☒	☒	☒	☒	☒
LLHL	CG RAM (3)	☒	☒	☒	☒	☒	☒	☒	☒	☒	☒	☒	☒	☒	☒	☒
LLHH	CG RAM (4)	☒	☒	☒	☒	☒	☒	☒	☒	☒	☒	☒	☒	☒	☒	☒
LHLL	CG RAM (5)	☒	☒	☒	☒	☒	☒	☒	☒	☒	☒	☒	☒	☒	☒	☒
LHLH	CG RAM (6)	☒	☒	☒	☒	☒	☒	☒	☒	☒	☒	☒	☒	☒	☒	☒
LHHL	CG RAM (7)	☒	☒	☒	☒	☒	☒	☒	☒	☒	☒	☒	☒	☒	☒	☒
LHHH	CG RAM (8)	☒	☒	☒	☒	☒	☒	☒	☒	☒	☒	☒	☒	☒	☒	☒
HLLL	CG RAM (9)	☒	☒	☒	☒	☒	☒	☒	☒	☒	☒	☒	☒	☒	☒	☒
HLLH	CG RAM (10)	☒	☒	☒	☒	☒	☒	☒	☒	☒	☒	☒	☒	☒	☒	☒
HLHL	CG RAM (11)	☒	☒	☒	☒	☒	☒	☒	☒	☒	☒	☒	☒	☒	☒	☒
HLHH	CG RAM (12)	☒	☒	☒	☒	☒	☒	☒	☒	☒	☒	☒	☒	☒	☒	☒
HHLL	CG RAM (13)	☒	☒	☒	☒	☒	☒	☒	☒	☒	☒	☒	☒	☒	☒	☒
HHLH	CG RAM (14)	☒	☒	☒	☒	☒	☒	☒	☒	☒	☒	☒	☒	☒	☒	☒
HHHL	CG RAM (15)	☒	☒	☒	☒	☒	☒	☒	☒	☒	☒	☒	☒	☒	☒	☒
HHHH	CG RAM (16)	☒	☒	☒	☒	☒	☒	☒	☒	☒	☒	☒	☒	☒	☒	☒

WESTERN EUROPEAN CHARACTER FONT TABLE I (FT[1:0]=01)

Upper 4bit Lower 4bit	LLLL	LLLH	LLHL	LLHH	LHLL	LHLH	LHHL	LHHH	HLLL	HLLH	HLHL	HLHH	HLLL	HHLH	HHHL	HHHH
LLLL	CG RAM (1)			ø	á	â	ã	ä	å	æ	ç	è	é	ê	ë	ü
LLLL	CG RAM (2)		!	1	À	Á	Â	Ã	Ä	Å	Æ	Ç	È	É	Ê	Ë
LLHL	CG RAM (3)		"	2	È	É	Ê	Ë	Ì	Í	Î	Ï	Ð	Ñ	Ò	Ó
LLHH	CG RAM (4)		#	3	Ó	Ô	Õ	Ö	Ø	Ù	Ú	Û	Ü	Ý	Þ	ß
LHLL	CG RAM (5)		*	4	Ð	Ñ	Ò	Ó	Ô	Õ	Ö	Ø	Ù	Ú	Û	Ü
LHLH	CG RAM (6)		z	5	È	É	Ê	Ë	Ì	Í	Î	Ï	Ð	Ñ	Ò	Ó
LHHL	CG RAM (7)		&	6	Ù	Ú	Û	Ü	Ý	Þ	ß	à	á	â	ã	ä
LHHH	CG RAM (8)		'	7	ä	å	æ	ç	è	é	ê	ë	ì	í	î	ï
HLLL	CG RAM (9)		ç	8	h	ï	ð	ñ	ò	ó	ô	õ	ö	÷	ø	ù
HLLH	CG RAM (10)		ç	9	í	î	ï	ð	ñ	ò	ó	ô	õ	ö	÷	ø
HLHL	CG RAM (11)		*	:	Ë	Ì	Í	Î	Ï	Ð	Ñ	Ò	Ó	Ô	Õ	Ö
HLHH	CG RAM (12)		+	;	Ë	Ì	Í	Î	Ï	Ð	Ñ	Ò	Ó	Ô	Õ	Ö
HHLL	CG RAM (13)		,	<	Ë	Ì	Í	Î	Ï	Ð	Ñ	Ò	Ó	Ô	Õ	Ö
HHLH	CG RAM (14)		-	=	Ë	Ì	Í	Î	Ï	Ð	Ñ	Ò	Ó	Ô	Õ	Ö
HHHL	CG RAM (15)		.	>	Ë	Ì	Í	Î	Ï	Ð	Ñ	Ò	Ó	Ô	Õ	Ö
HHHH	CG RAM (16)		/	?	Ë	Ì	Í	Î	Ï	Ð	Ñ	Ò	Ó	Ô	Õ	Ö

ENGLISH_RUSSIAN CHARACTER FONT TABLE(FT[1:0]=10)

Upper 4bit	LLLL	LLLH	LLHL	LLHH	LHLL	LHLH	LHHL	LHHH	HLLL	HLLH	HLHL	HLHH	HHLL	HHLH	HHHL	HHHH
LLLL	CG RAM (1)	А	В	С	Д	Е	Ж	З	И	Й	К	Л	М	Н	О	П
LLLL	CG RAM (2)	а	б	в	г	д	е	ж	з	и	й	к	л	м	н	о
LLHL	CG RAM (3)	А	В	С	Д	Е	Ж	З	И	Й	К	Л	М	Н	О	П
LLHH	CG RAM (4)	А	В	С	Д	Е	Ж	З	И	Й	К	Л	М	Н	О	П
LHLL	CG RAM (5)	А	В	С	Д	Е	Ж	З	И	Й	К	Л	М	Н	О	П
LHLH	CG RAM (6)	А	В	С	Д	Е	Ж	З	И	Й	К	Л	М	Н	О	П
LHHL	CG RAM (7)	А	В	С	Д	Е	Ж	З	И	Й	К	Л	М	Н	О	П
LHHH	CG RAM (8)	А	В	С	Д	Е	Ж	З	И	Й	К	Л	М	Н	О	П
HLLL	CG RAM (9)	А	В	С	Д	Е	Ж	З	И	Й	К	Л	М	Н	О	П
HLLH	CG RAM (10)	А	В	С	Д	Е	Ж	З	И	Й	К	Л	М	Н	О	П
HLHL	CG RAM (11)	А	В	С	Д	Е	Ж	З	И	Й	К	Л	М	Н	О	П
HLHH	CG RAM (12)	А	В	С	Д	Е	Ж	З	И	Й	К	Л	М	Н	О	П
HHLL	CG RAM (13)	А	В	С	Д	Е	Ж	З	И	Й	К	Л	М	Н	О	П
HHLH	CG RAM (14)	А	В	С	Д	Е	Ж	З	И	Й	К	Л	М	Н	О	П
HHHL	CG RAM (15)	А	В	С	Д	Е	Ж	З	И	Й	К	Л	М	Н	О	П
HHHH	CG RAM (16)	А	В	С	Д	Е	Ж	З	И	Й	К	Л	М	Н	О	П

WESTERN EUROPEAN CHARACTER FONT TABLE II (FT[1:0]=1)

Upper 4bit Lower 4bit	LLLL	LLLH	LLHL	LLHH	LHLL	LHLH	LHHL	LHHH	HLLL	HLLH	HLHL	HLHH	HHLL	HHLH	HHHL	HHHH
LLLL	CG RAM (1)	±	⊞	⊞	⊞	⊞	⊞	⊞	⊞	⊞	⊞	⊞	⊞	⊞	⊞	⊞
LLLL	CG RAM (2)	≡	!	1	⊞	⊞	⊞	⊞	⊞	⊞	⊞	⊞	⊞	⊞	⊞	⊞
LLHL	CG RAM (3)	⊞	"	2	⊞	⊞	⊞	⊞	⊞	⊞	⊞	⊞	⊞	⊞	⊞	⊞
LLHH	CG RAM (4)	⊞	#	3	⊞	⊞	⊞	⊞	⊞	⊞	⊞	⊞	⊞	⊞	⊞	⊞
LHLL	CG RAM (5)	⊞	4	⊞	⊞	⊞	⊞	⊞	⊞	⊞	⊞	⊞	⊞	⊞	⊞	⊞
LHLH	CG RAM (6)	⊞	5	⊞	⊞	⊞	⊞	⊞	⊞	⊞	⊞	⊞	⊞	⊞	⊞	⊞
LHHL	CG RAM (7)	⊞	6	⊞	⊞	⊞	⊞	⊞	⊞	⊞	⊞	⊞	⊞	⊞	⊞	⊞
LHHH	CG RAM (8)	⊞	7	⊞	⊞	⊞	⊞	⊞	⊞	⊞	⊞	⊞	⊞	⊞	⊞	⊞
HLLL	CG RAM (9)	⊞	⊞	⊞	⊞	⊞	⊞	⊞	⊞	⊞	⊞	⊞	⊞	⊞	⊞	⊞
HLLH	CG RAM (10)	⊞	⊞	⊞	⊞	⊞	⊞	⊞	⊞	⊞	⊞	⊞	⊞	⊞	⊞	⊞
HLHL	CG RAM (11)	⊞	⊞	⊞	⊞	⊞	⊞	⊞	⊞	⊞	⊞	⊞	⊞	⊞	⊞	⊞
HLHH	CG RAM (12)	⊞	⊞	⊞	⊞	⊞	⊞	⊞	⊞	⊞	⊞	⊞	⊞	⊞	⊞	⊞
HHLL	CG RAM (13)	⊞	⊞	⊞	⊞	⊞	⊞	⊞	⊞	⊞	⊞	⊞	⊞	⊞	⊞	⊞
HHLH	CG RAM (14)	⊞	⊞	⊞	⊞	⊞	⊞	⊞	⊞	⊞	⊞	⊞	⊞	⊞	⊞	⊞
HHHL	CG RAM (15)	⊞	⊞	⊞	⊞	⊞	⊞	⊞	⊞	⊞	⊞	⊞	⊞	⊞	⊞	⊞
HHHH	CG RAM (16)	⊞	⊞	⊞	⊞	⊞	⊞	⊞	⊞	⊞	⊞	⊞	⊞	⊞	⊞	⊞

8. Block Diagram

Instruction	Code										Description	Max. Execution Time when fsp or fosc = 250KHz	
	RS	R/WB	DB7	DB6	DB5	DB4	DB3	DB2	DB1	DB0			
Clear Display	0	0	0	0	0	0	0	0	0	0	1	Clears entire display. Sets DDRAM Address 0 into the Address Counter	6.2ms
Return Home	0	0	0	0	0	0	0	0	0	1	0	Sets DDRAM Address 0 into the Address Counter. Returns shifted display to original position. DDRAM contents remain unchanged. (DB0 is test pin. User should set DB0=0 all the time)	0
Entry Mode Set	0	0	0	0	0	0	0	1	I/D	S		Sets cursor move direction and specifies display shift. (These operations are performed during data write and read.)	0
Display ON/OFF Control	0	0	0	0	0	0	1	D	C	B		Sets entire Display (D) ON/OFF. Sets Cursor (C) ON/OFF. Sets Blinking (B) of Cursor Position Character.	0
Cursor/ Display Shift/ Mode/ Pwr	0	0	0	0	0	1	S/C	R/L	0	0		Moves cursor & shifts display without changing DDRAM contents.	0
							G/C	PWR	1	1		Sets Graphical/Character Mode Sets internal power on/off	
Function Set	0	0	0	0	1	DL	N	F	FT1	FT0		Sets interface data length (DL). Sets number of display lines (N). Sets Character Font (F). Sets Font Table (FT)	0
Set CGRAM Address	0	0	0	1	ACG	ACG	ACG	ACG	ACG	ACG	ACG	Sets CGRAM Address. CGRAM data is sent and received after this setting.	0
Set DDRAM Address	0	0	1	ADD	ADD	ADD	ADD	ADD	ADD	ADD	ADD	Sets DDRAM Address. The DDRAM data is sent and received after this setting.	0
Read Busy Flag & Address	0	1	BF	AC	AC	AC	AC	AC	AC	AC	AC	Reads Busy Flag (BF) indicating that internal operation is being performed. Reads Address Counter contents.	0
Write data into the CGRAM or DDRAM	1	0	Write Data								Writes data into the CGRAM or DDRAM	0	
Read Data from the CGRAM or DDRAM	1	1	Read Data								Read data from the CGRAM or DDRAM	0	

9. Timing Characteristics

AC CHARACTERISTICS

Read / Write Characteristics (8080-series MPU)

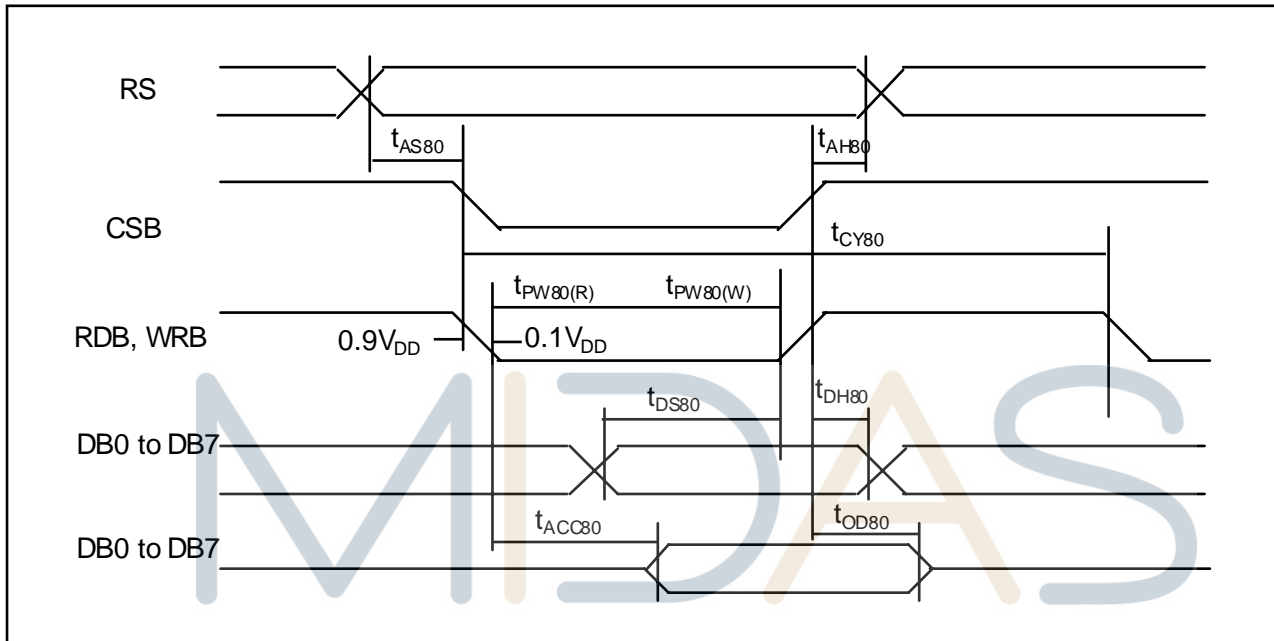

Figure 1. Read / Write Characteristics (8080-series MPU)

VDD = 4.7 to 5.3V, Ta = 25°C)

Item	Signal	Symbol	Min.	Typ.	Max.	Unit	Remark
Address setup time	RS	tAS80	20	-	-	ns	
Address hold time		tAH80	0	-	-	ns	
System cycle time		tCY80	500	-	-	ns	
Pulse width (WRB)	RW_WRB	tPW80(W)	250	-	-	ns	
Pulse width (RDB)	E_RDB	tPW80(R)	250	-	-	ns	
Data setup time	DB7 to DB0	tDS80	40	-	-	ns	
Data hold time		tDH80	20	-	-	ns	
Read access time	DB0	tACC80	-	-	180	ns	CL = 100pF
Output disable time		tOD80	10	-	-	ns	

Read / Write Characteristics (6800-series Microprocessor)

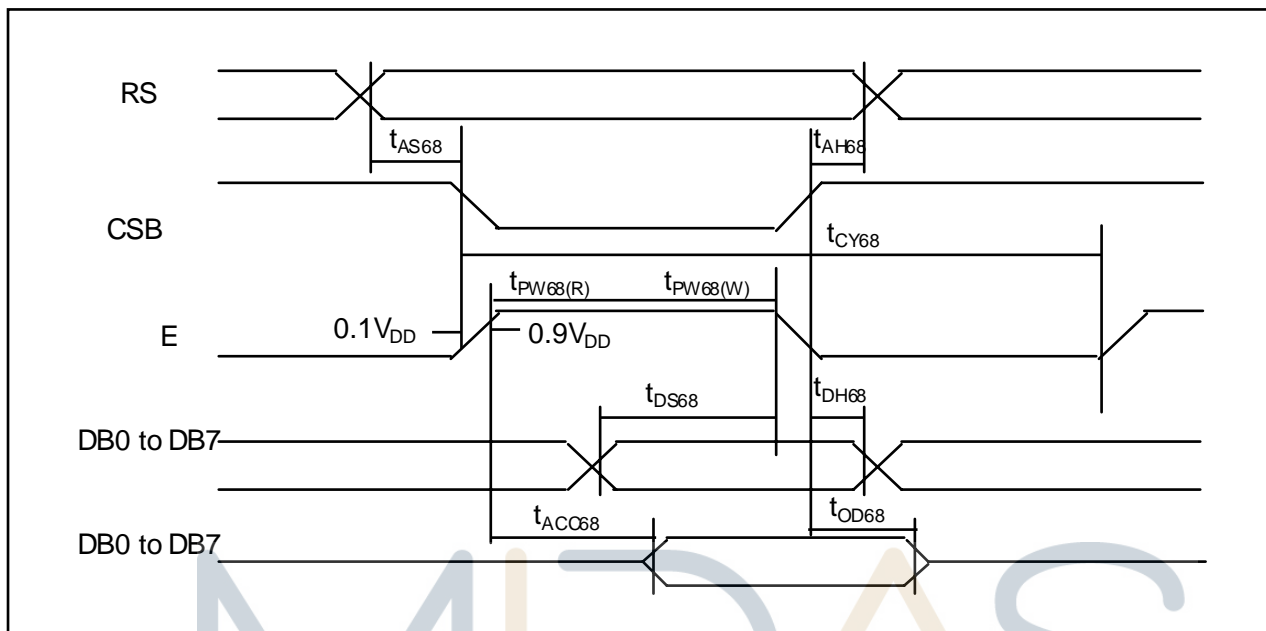

Figure 2. Read / Write Characteristics (6800-series MPU)

($V_{DD} = 4.7$ to $5.3V$, $T_a = 25^\circ C$)

Item	Signal	Symbol	Min.	Typ.	Max.	Unit	Remark
Address setup time	RS	t_{AS68}	20	-	-	ns	
Address hold time	RS	t_{AH68}	0	-	-	ns	
System cycle time		t_{CY68}	500	-	-	ns	
Pulse width (E)	E_RDB	$t_{PW68(W)}$	250	-	-	ns	
Pulse width (E)	E_RDB	$t_{PW68(R)}$	250	-	-	ns	
Data setup time	DB7	t_{DS68}	40	-	-	ns	
Data hold time	DB7 to DB0	t_{DH68}	20	-	-	ns	
Read access time	DB0	t_{ACC68}	-	-	180	ns	$CL = 100pF$
Output disable time	DB0	t_{OD68}	10	-	-	ns	

Serial Interface Characteristics

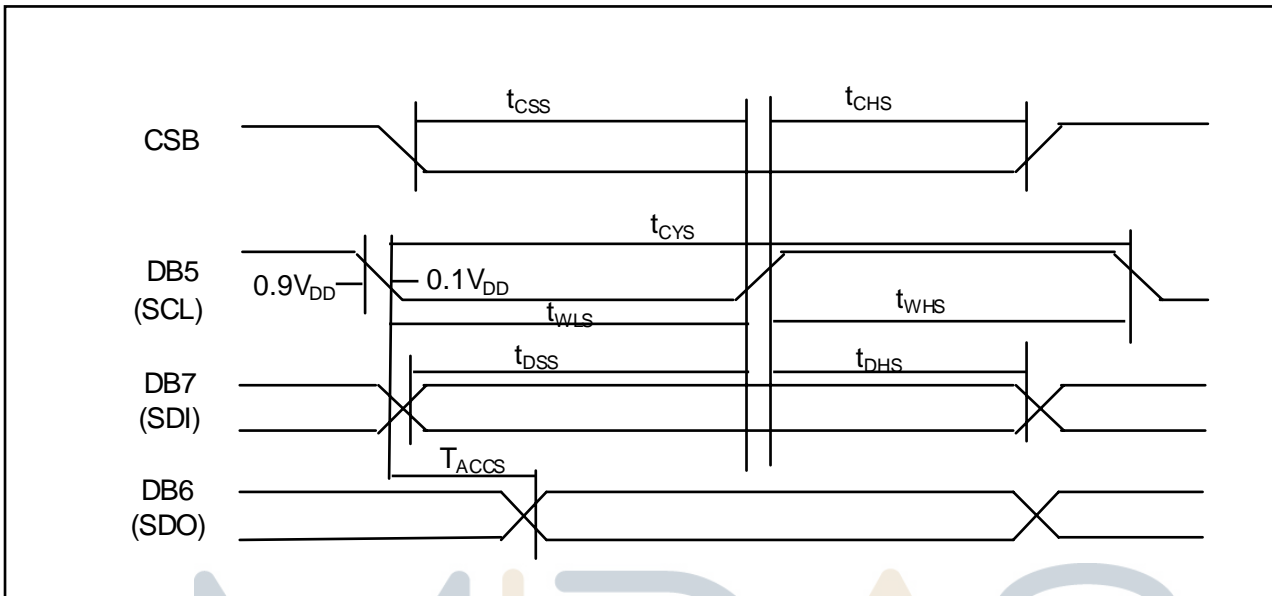

Figure 3. Serial Interface Characteristics

(VDD = 4.7 to 5.3V, Ta = 25°C)

Item	Signal	Symbol	Min.	Typ.	Max.	Unit	Remark
Serial clock cycle	DB5 (SCL)	tCYS	300	-	-	-	
SCL high pulse width	DB5 (SCL)	tWHS	100	-	-	ns	
SCL low pulse width	DB5 (SCL)	tWLS	100	-	-	ns	
CSB setup time	CSB	tCSS	150	-	-	ns	
CSB hold time	CSB	tCHS	150	-	-	ns	
Data setup time	DB7 (SDI)	tDSS	100	-	-	ns	
Data hold time	DB7 (SDI)	tDHS	100	-	-	ns	
Read access time	DB6 (SDO)	tACCS	-	-	80	ns	

Serial Interface Characteristics

10. Initializing of OLED Module

(1) 8-bit mode

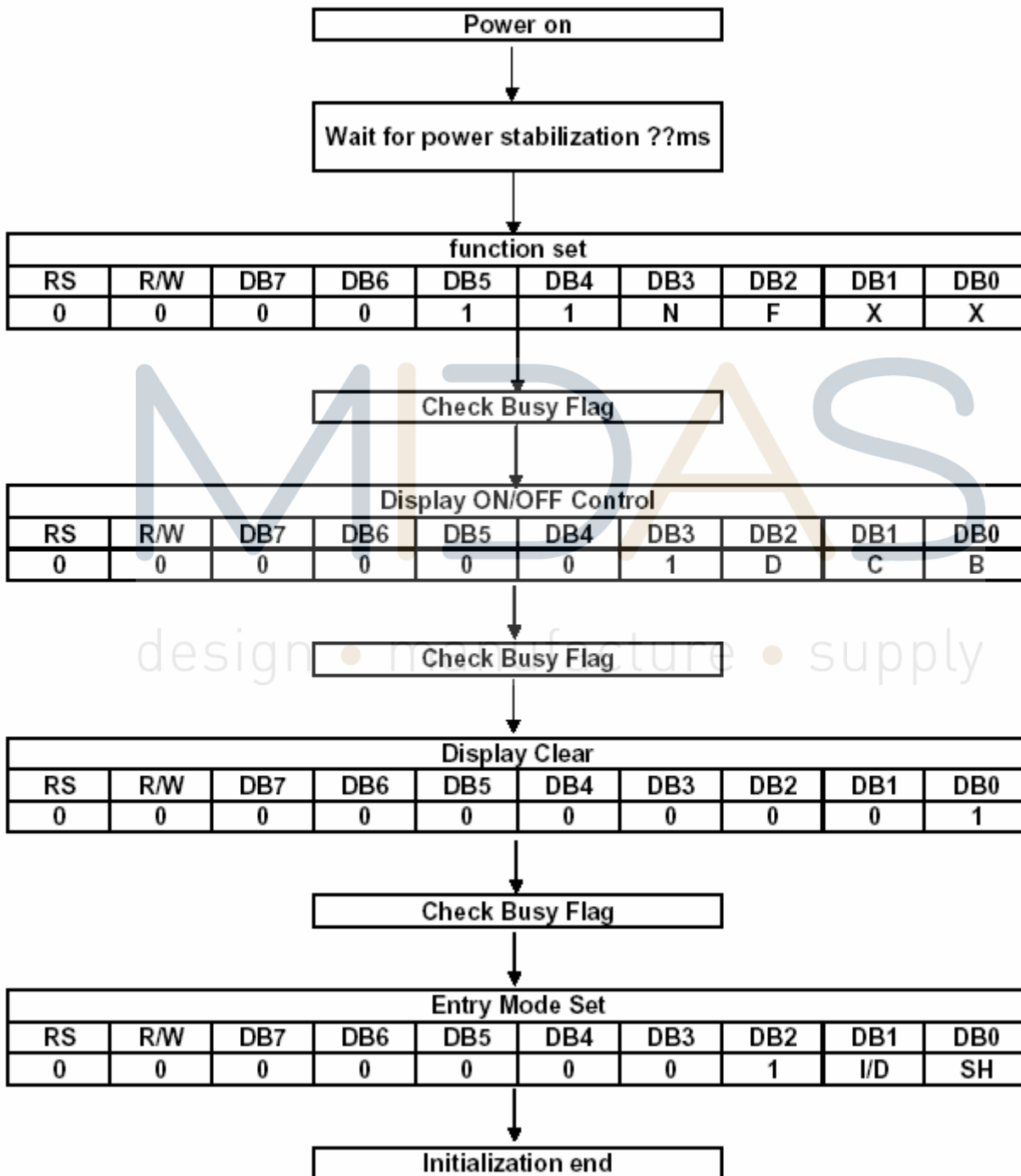

(2)4-bit mode

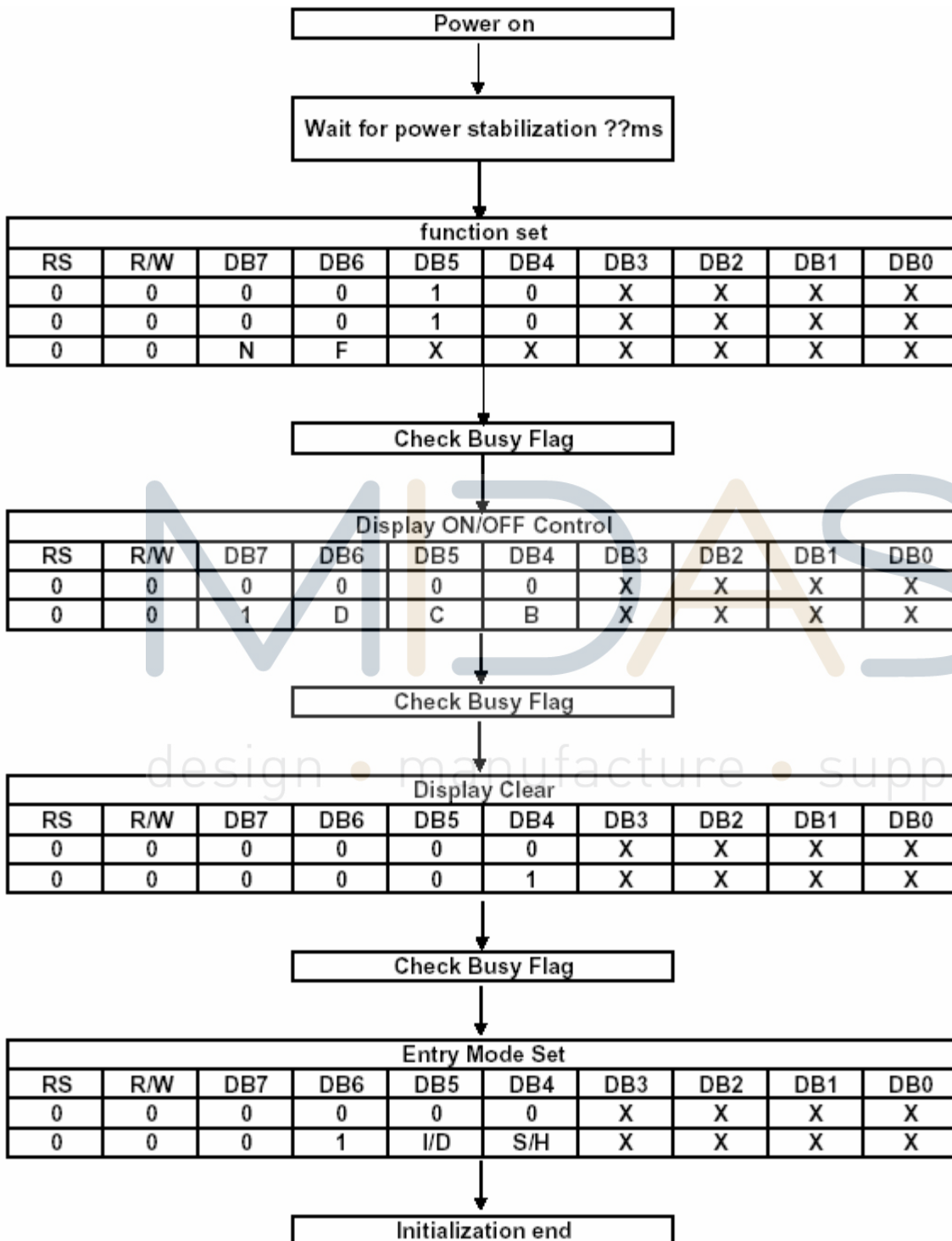

INSTRUCTIONS

IC Instruction Register (IR) and Data Register (DR) are the only registers that can be controlled by the MPU. Prior to the commencement of its internal operation, IC temporarily stores the control information to its Instruction Register (IR) and Data Register (DR) in order to easily facilitate interface with various types of MPU. The internal operations of the IC are determined by the signals (RS, R/WB, DB0 to DB7) that are sent from the MPU. These signals are categorized into 4 instructions types, namely:

- 1, Function Setting Instructions (i.e. Display, Format, Data Length etc.)
2. Internal RAM Address Setting Instructions
3. Data Transfer with Internal RAM Instructions
4. Miscellaneous Function Instructions

The generally used instructions are those that execute data transfers with the internal RAM. However, when the internal RAM addresses are auto incremented/decremented by 1 after each Data Write, the program load of the MPU is lightened. The Display Shift Instruction can be executed at the same time as the Display Data Write, thereby minimizing system development time with maximum programming efficiency.

When an instruction is being executed for an internal operation, only the Busy Flag/Address Read Instruction can be performed. The other instructions are not valid. It should be noted that during the execution of an instruction, the Busy Flag is set to "1". The Busy Flag is set to "0" when the instructions are can be accepted and executed. Therefore, the Busy Flag should be checked to make certain that BF = "0" before sending another instruction from the MPU. If not, the time between the first instruction and the next instruction is longer than the time it takes to execute the instruction itself.

Instruction	Code										Description	Max. Execution Time when fsp or fosc = 250KHz	
	RS	R/WB	DB7	DB6	DB5	DB4	DB3	DB2	DB1	DB0			
Clear Display	0	0	0	0	0	0	0	0	0	0	1	Clears entire display. Sets DDRAM Address 0 into the Address Counter	6.2ms
Return Home	0	0	0	0	0	0	0	0	0	1	0	Sets DDRAM Address 0 into the Address Counter. Returns shifted display to original position. DDRAM contents remain unchanged. (DB0 is test pin. User should set DB0=0 all the time)	0
Entry Mode Set	0	0	0	0	0	0	0	1	I/D	S		Sets cursor move direction and specifies display shift. (These operations are performed during data write and read.)	0
Display ON/OFF Control	0	0	0	0	0	0	1	D	C	B		Sets entire Display (D) ON/OFF. Sets Cursor (C) ON/OFF. Sets Blinking (B) of Cursor Position Character.	0
Cursor/ Display Shift/ Mode/ Pwr	0	0	0	0	0	1	S/C	R/L	0	0		Moves cursor & shifts display without changing DDRAM contents.	0
							G/C	PWR	1	1		Sets Graphical/Character Mode Sets internal power on/off	
Function Set	0	0	0	0	1	DL	N	F	FT1	FT0		Sets interface data length (DL). Sets number of display lines (N). Sets Character Font (F). Sets Font Table (FT)	0
Set CGRAM Address	0	0	0	1	ACG	ACG	ACG	ACG	ACG	ACG	ACG	Sets CGRAM Address. CGRAM data is sent and received after this setting.	0
Set DDRAM Address	0	0	1	ADD	ADD	ADD	ADD	ADD	ADD	ADD	ADD	Sets DDRAM Address. The DDRAM data is sent and received after this setting.	0
Read Busy Flag & Address	0	1	BF	AC	AC	AC	AC	AC	AC	AC	AC	Reads Busy Flag (BF) indicating that internal operation is being performed. Reads Address Counter contents.	0
Write data into the CGRAM or DDRAM	1	0	Write Data								Writes data into the CGRAM or DDRAM	0	
Read Data from the CGRAM or DDRAM	1	1	Read Data								Read data from the CGRAM or DDRAM	0	

Notes:

1. After the CGRAM/DDRAM Read or Write Instruction has been executed, the RAM Address Counter is incremented or decremented by 1. After the Busy Flag is turned OFF, the RAM Address is updated.
2. I/D=Increment/Decrement Bit
 - I/D="1": Increment
 - I/D="0": Decrement
3. S=Shift Entire Display Control Bit. When S="0", shift function disable.
4. BF=Busy Flag
 - BF="1": Internal Operating in Progress
 - BF="0": No Internal Operation is being executed, next instruction can be accepted.
5. R/L=Shift Right/Left
 - R/L="1": Shift to the Right
 - R/L="0": Shift to the Left
6. S/C=Display Shift/Cursor Move
 - S/C="1": Display Shift
 - S/C="0": Cursor Move
7. G/C=Graphic/Character mode selection. G/C="0", Character mode is selected. G/C="1", Graphic mode is selected.
8. PWR=Internal DCDC on/of control. PWR="1", DCDC on. PWR="0", DCDC off.
9. DDRAM=Display Data RAM
10. CGRAM=Character Generator RAM
11. ACG=CGRAM Address
12. ADD=Address Counter Address (corresponds to cursor address)
13. AC=Address Counter (used for DDRAM and CGRAM Addresses)
14. F=Character Pattern Mode
 - F="1": 5 x 10 dots
 - F="0": 5 x 8 dots
15. N=Number of Lines Displayed
 - N="1": 2-Line Display
 - N="0": 1-Line Display

INSTRUCTION DESCRIPTION

CLEAR DISPLAY INSTRUCTION

RS	R/WB	DB7	DB6	DB5	DB4	DB3	DB2	DB1	DB0
0	0	0	0	0	0	0	0	0	1

This instruction is used to clear the Display Write Space 20H in all DDRAM Addresses. That is, the character pattern for the Character Code 20H must be a BLANK pattern. It then sets the DDRAM Address 0 into the Address Counter and reverts the display to its original state (if the display has been shifted). The display will be cleared and the cursor or blinking will go to the left edge of the display. If there are 2 lines displayed, the cursor or blinking will go to the first line's left edge of the display.

Under the Entry Mode, this instruction also sets the I/D to 1 (Increment Mode). The S Bit of the Entry Mode does not change.

RETURN HOME INSTRUCTION

RS	R/WB	DB7	DB6	DB5	DB4	DB3	DB2	DB1	DB0
0	0	0	0	0	0	0	0	1	*

Note: * = Not Relevant

This instruction is used to set the DDRAM Address 0 into the Address Counter and revert the display to its original status (if the display has been shifted). The DDRAM contents do not change. The cursor or blinking will go to the left edge of the display. If there are 2 lines displayed, the cursor or blinking will go to the first line's left edge of the display.

ENTRY MODE SET INSTRUCTION

The Entry Mode Set Instruction has two controlling bits: I/D and S. Please refer to the table below.

RS	R/WB	DB7	DB6	DB5	DB4	DB3	DB2	DB1	DB0
0	0	0	0	0	0	0	1	I/D	S

I/D IS THE INCREMENT/DECREMENT BIT.

When I/D is set to "1", the DDRAM Address is incremented by "1" when a character code is written into or read from the DDRAM. An increment of 1 will move the cursor or blinking one step to the right. When I/D is set to "0", the DDRAM is decremented by 1 when a character code is written into or read from the DDRAM. A decrement of 1 will move the cursor or blinking one step to the left.

S: SHIFT ENTIRE DISPLAY CONTROL BIT

This bit is used to shift the entire display. When S is set to "1", the entire display is shifted to the right (when I/D = "0") or left (when I/D = "1"). When S is set to "0", the display is not shifted.

Ex1 : I/D=1, S=1

		1	2	3	4	_		Initial display
	1	2	3	4	A	_		Input new character "A"
1	2	3	4	A	B	_		Input new character "B"
2	3	4	A	B	C	_		Input new character "C"
3	4	A	B	C	D	_		Input new character "D"

Ex2 : I/D=0, S=1

1	2	3	4	_				Initial display
	1	2	3	4	A			Input new character "A"
		1	2	3	B	A		Input new character "B"
			1	2	C	B		Input new character "C"
				1	D	C		Input new character "D"

DISPLAY ON/OFF CONTROL INSTRUCTION

The Display On / OFF Instruction is used to turn the display ON or OFF. The controlling bits are D, C and B.

RS	R/WB	DB7	DB6	DB5	DB4	DB3	DB2	DB1	DB0
----	------	-----	-----	-----	-----	-----	-----	-----	-----

0	0	0	0	0	0	1	D	C	B
---	---	---	---	---	---	---	---	---	---

CURSOR/DISPLAY SHIFT INSTRUCTION

This instruction is used to shift the cursor or display position to the left or right without writing or reading the Display Data. This function is used to correct or search the display. Please refer to the table below.

RS	R/WB	DB7	DB6	DB5	DB4	DB3	DB2	DB1	DB0
0	0	0	0	0	1	S/C	R/L	0	0
0	0	0	0	0	1	G/C	PW	1	1

S/C	R/L	Shift Function
0	0	Shifts the cursor position to the left. (AC is decremented by 1).
0	1	Shifts cursor position to the right. (AC incremented by 1).
1	0	Shifts entire display to the left. The cursor follows the display shift.
1	1	Shifts the entire display to the right. The cursor follows the display shift.

In a 2-line Display, the cursor moves to the second line when it passes the 40th digit of the first line.

The first and second line displays will shift at the same time.

When the displayed data is shifted repeatedly, each line moves only horizontally. The second line display does not shift into the first line position.

The Address Counter (AC) contents will not change if the only action performed is a Display Shift.

G/C: GRAPHIC MODE / CHARACTER MODE SELECTION

This bit is used to select the display mode for further process.

When G/C = 1, the *GRAPHIC MODE* will be selected.

When G/C = 0, the *CHARACTER MODE* will be selected.

PWR: ENABLE/DISABLE INTERNAL POWER

This bit is used to turn ON or turn OFF the internal power.

When PWR = 1, the internal power is turned ON.

When PWR = 0, the internal power is turned OFF.

FUNCTION SET INSTRUCTION

The Function Set Instruction has three controlling 3 bits, namely: DL, N and F. Please refer to the table below.

RS	R/WB	DB7	DB6	DB5	DB4	DB3	DB2	DB1	DB0
----	------	-----	-----	-----	-----	-----	-----	-----	-----

0	0	0	0	1	DL	N	F	FT1	FT0
---	---	---	---	---	----	---	---	-----	-----

DL: INTERFACE DATA LENGTH CONTROL BIT

This is used to set the interface data length. When DL is set to "1", the data is sent or received in 8-bit length via the DB0 to DB7 (for an 8-Bit Data Transfer). When DL is set to "0", the data is sent or

received in 4-bit length via DB4 to DB7 (for a 4-Bit Data Transfer). When the 4-bit data length is selected, the data must be sent or received twice.

N: NUMBER OF DISPLAY LINE

This is used to set the number of display lines. When N="1", the 2-line display is selected. When N is

set to "0", the 1-line display is selected.

F: CHARACTER FONT SET

This is used to set the character font set. When F is set to "0", the 5 x 8 dot character font is selected. When F is set to "1", the 5 x 10 dot character font is selected.

It must be noted that the character font setting must be performed at the head of the program before executing any instructions other than the Busy Flag and Address Instruction. Otherwise, the Function

Set Instruction cannot be executed unless the interface data length is changed.

FT1, FT0: FONT TABLE SELECTION

These two bits are used to select one font table out of the three for further process.

When (FT1, FT0) = (0, 0), the *ENGLISH_JAPANESE CHARACTER FONT TABLE* will be selected.

(FT1, FT0) = (0, 1), the *WESTERN EUROPEAN CHARACTER FONT TABLE* will be selected.

(FT1, FT0) = (1, 0), the *ENGLISH_RUSSIAN CHARACTER FONT TABLE* will be selected.

(FT1, FT0) = (1, 1), N/A

Note: The default setting for FT1 and FT0 is 0 and 0 respectively which means the default Font Table

is *ENGLISH_JAPANESE CHARACTER FONT TABLE*.

SET CGRAM ADDRESS INSTRUCTION

This instruction is used to set the CGRAM Address binary AAAAAA into the Address Counter. Data is then written to or read from the MPU for CGRAM.

RS	R/WB	DB7	DB6	DB5	DB4	DB3	DB2	DB1	DB0
0	0	0	0	ACG	ACG	ACG	ACG	ACG	ACG

Note: ACG is the CGRAM Address

SET DDRAM ADDRESS INSTRUCTION

This instruction is used to set the DDRAM Address binary AAAAAAA into the Address Counter.

The data is written to or read from the MPU for the DDRAM. If 1-line display is selected (N="0"), then AAAAAAA can be 00H to 4FH. When the 2-line display is selected, then AAAAAAA can be 00H to 27H for the first line and 40H to 67H for the second line.

RS	R/WB	DB7	DB6	DB5	DB4	DB3	DB2	DB1	DB0
0	0	1	ADD	ADD	ADD	ADD	ADD	ADD	ADD

Note: ADD = DDRAM Address

READ BUSY FLAG AND ADDRESS INSTRUCTION

This instruction is used to read the Busy Flag (BF) to indicate if IC is internally operating on a previously received instruction. If BF is set to "1", then the internal operation is in progress and the next instruction will not be accepted. If the BF is set to "0", then the previously received instruction has been executed and the next instruction can be accepted and processed. It is important to check the BF

status before proceeding to the next write operation. The value of the Address Counter in binary AAAAAAA is simultaneously read out. This Address Counter is used by both the CGRAM and the DDRAM and its value is determined by the previous instruction. The contents of the address are the same as for the instructions -- Set CGRAM Address and Set DDRAM Address.

RS	R/WB	DB7	DB6	DB5	DB4	DB3	DB2	DB1	DB0
0	1	BF	AC	AC	AC	AC	AC	AC	AC

Notes:

1. BF=Busy Flag
2. AC=Address Counter

WRITE DATA TO CGRAM / DDRAM INSTRUCTION

This instruction writes 8-bit binary data -- DDDDDDDD to the CGRAM or the DDRAM. The previous CGRAM or DDRAM Address setting determines whether a data is to be written into the CGRAM or the DDRAM. After the write process is completed, the address is automatically incremented or

decremented by 1 in accordance with the Entry Mode instruction. It must be noted that the Entry Mode instruction also determines the Display Shift.

RS	R/WB	DB7	DB6	DB5	DB4	DB3	DB2	DB1	DB0
1	0	D	D	D	D	D	D	D	D

READ DATA FROM THE CGRAM OR DDRAM INSTRUCTION

This instruction reads the 8-bit binary data -- DDDDDDDD from the CGRAM or the DDRAM. The Set CGRAM Address or Set DDRAM Address Set Instruction must be executed before this instruction can be performed, otherwise, the first Read Data will not be valid.

RS	R/WB	DB7	DB6	DB5	DB4	DB3	DB2	DB1	DB0
1	1	D	D	D	D	D	D	D	D

MPU INTERFACE

IC provides High-speed 8-bit parallel bi-directional interface with 6800-series or 8080-series and serial interface. User can choice by signal "PS" and "C68".

68 – series interface

(a) 8-BIT mode (Not available for serial mode)

When IC interfaces with an 8-bit MPU, DB0 to DB7 are used. The 8-bit data transfer starts from the four high order bits --DB4 to DB7 followed by the four low order bits -- DB0 to DB3. An example of a Busy Flag Check Timing in an 8-Bit MPU Interface is given in the diagram.

(b) 4-BIT mode (Not available for serial mode)

IC can be configured to interface with a 4-bit MPU and is selected via a program. If the I/O port of the 4-Bit MPU from which IC is connected to, is capable of transferring 8 bits, then an 8-bit data transfer operation is executed. Otherwise, two 4-bit data transfer operations are needed to

satisfy one complete data transfer. Under the 4-bit data transfer, DB4 to DB7 are used as bus lines. DB0 to DB3 are disabled. The data transfer between IC and MPU is completed after two 4-bit data have been transferred. The Busy Flag must be checked (one instruction) after completion of the data transfer (that is, 4-bit data has been transferred twice.). The Busy Flag must be checked after two 4-bits data transfer has been completed. Please refer to the diagram below for a 4-bit data transfer timing sequence.

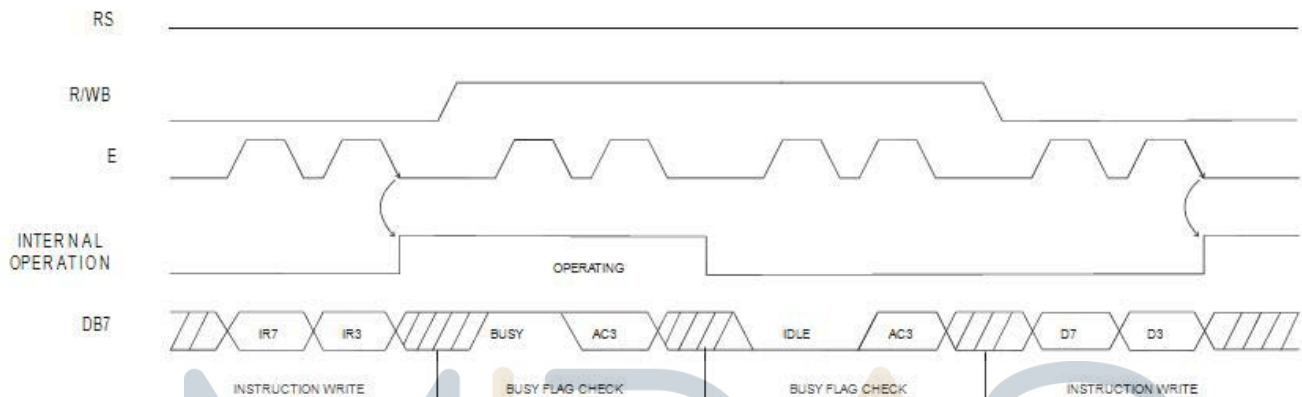

where:

1. IR7=Instruction Bit 7
2. IR3=Instruction Bit 3
3. AC3=Address Counter 3

From the above timing diagram, it is important to note that the Busy Flag Check and the data transfer are both executed twice.

80 – series interface

(a) 8-BIT mode

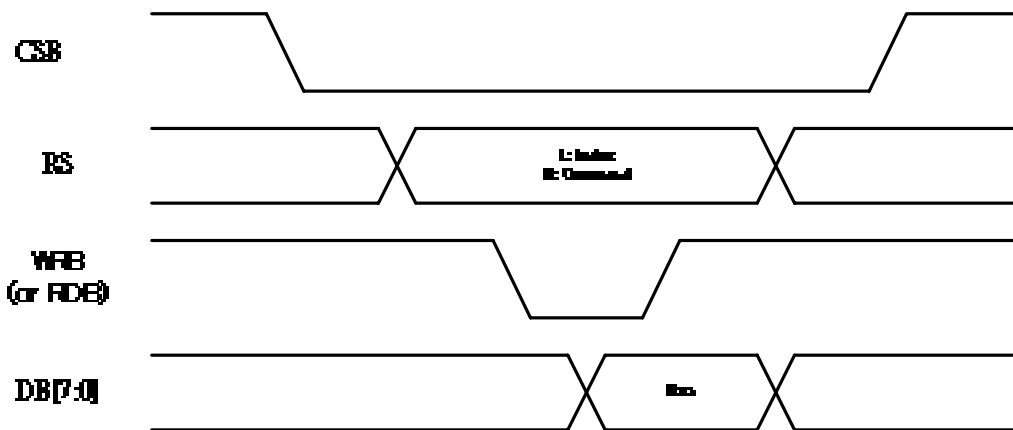

(b) 4-BIT mode

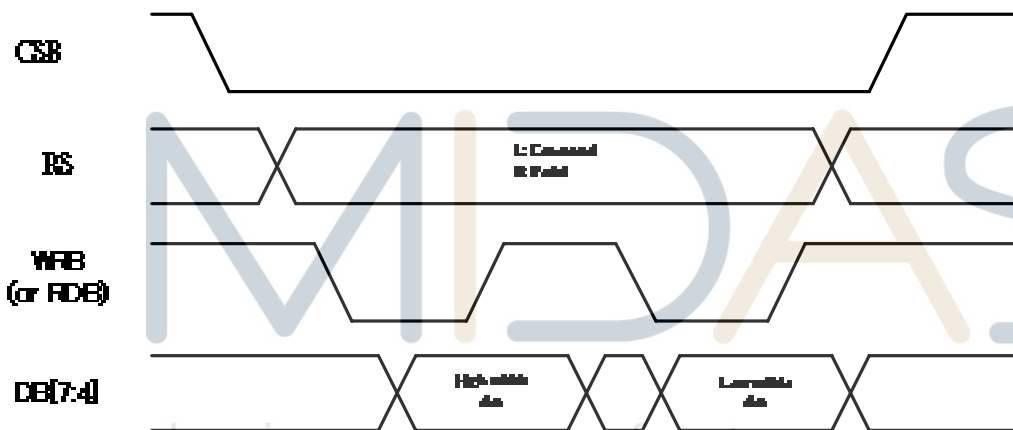

Serial interface

3-Line series Write/Read

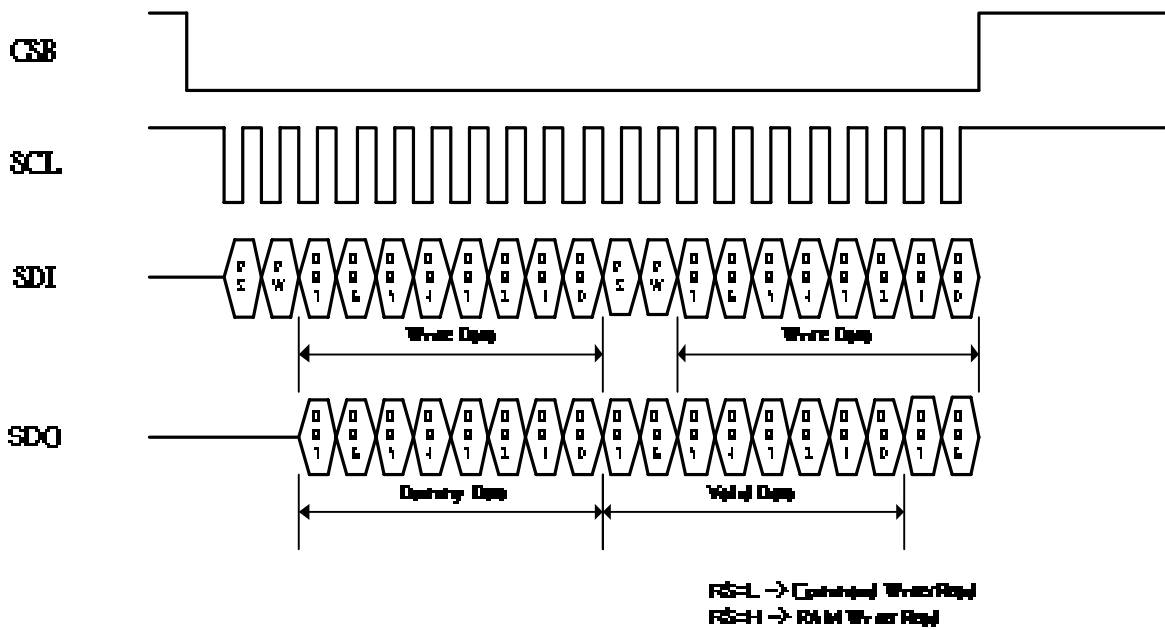

AC CHARACTERISTICS

Read / Write Characteristics (8080-series MPU)

design • manufacture • supply

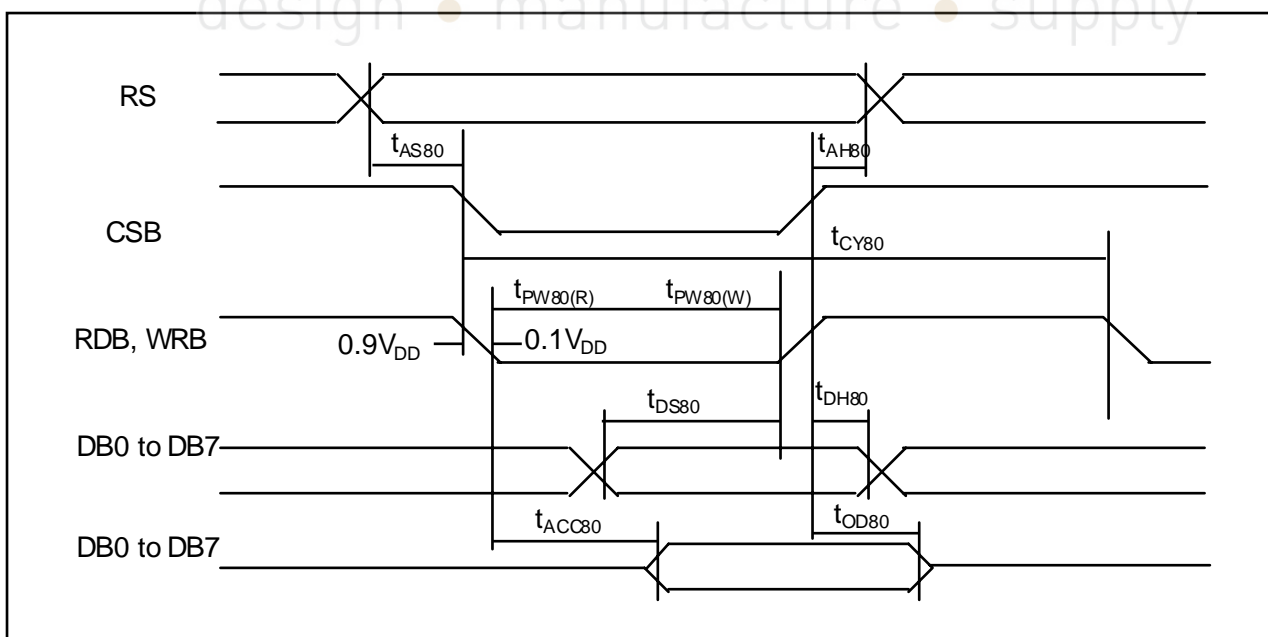

Figure 1. Read / Write Characteristics (8080-series MPU)

VDD = 4.7 to 5.3V, Ta = -40 to +85°C)

Item	Signal	Symbol	Min.	Typ.	Max.	Unit	Remark
Address setup time	RS	tAS80	0	-	-	ns	
Address hold time		tAH80	0	-	-	ns	
System cycle time		tCY80	300	-	-	ns	
Pulse width (WRB)	RW_WRB	tPW80(W)	80	-	-	ns	
Pulse width (RDB)	E_RDB	tPW80(R)	80	-	-	ns	
Data setup time	DB7 to DB0	tDS80	40	-	-	ns	
Data hold time		tDH80	15	-	-	ns	
Read access time	DB0	tACC80	-	-	140	ns	CL = 100pF
Output disable time		tOD80	10	-	100	ns	

Read / Write Characteristics (6800-series Microprocessor)

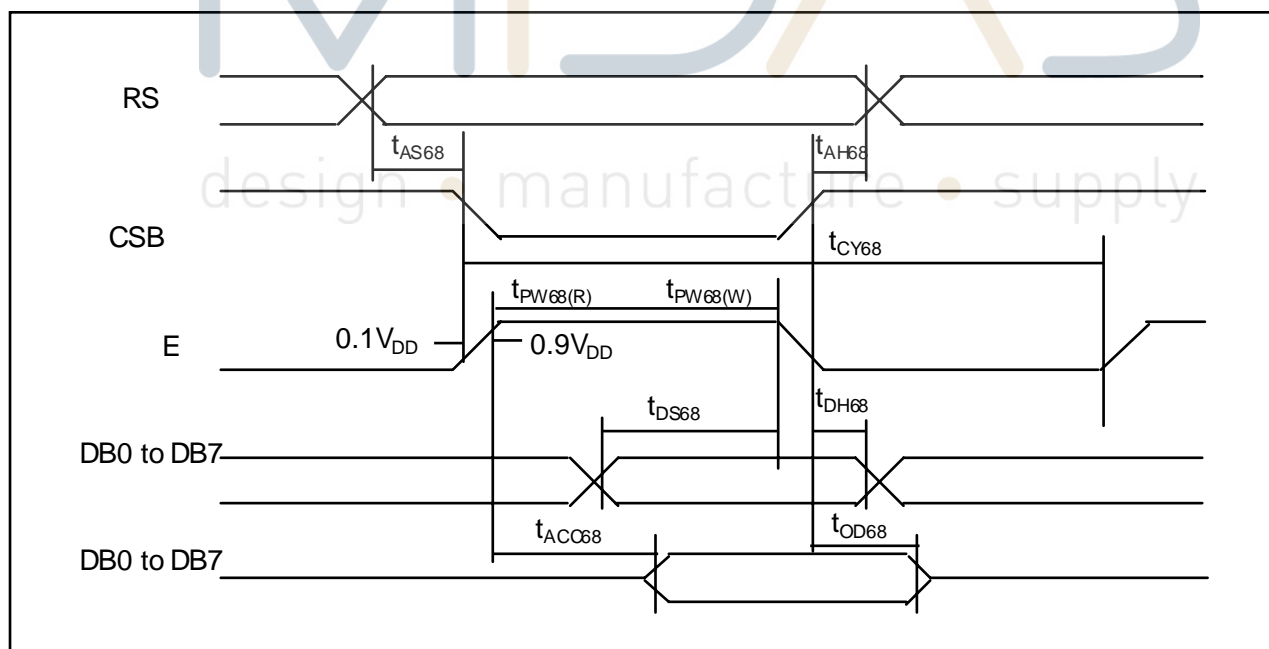

Figure 2. Read / Write Characteristics (6800-series MPU)

(VDD = 4.7 to 5.3V, Ta = -40 to +85°C)

Item	Signal	Symbol	Min.	Typ.	Max.	Unit	Remark
Address setup time	RS	tAS68	0	-	-	ns	
Address hold time		tAH68	0	-	-	ns	
System cycle time		tCY68	300	-	-	ns	
Pulse width (E)	E_RDB	tPW68(W)	80	-	-	ns	
Pulse width (E)	E_RDB	tPW68(R)	80	-	-	ns	
Data setup time	DB7 to DB0	tDS68	40	-	-	ns	
Data hold time		tDH68	0	-	-	ns	
Read access time	DB0	tACC68	-	-	70	ns	CL = 100pF
Output disable time		tOD68	5	-	50	ns	

Serial Interface Characteristics

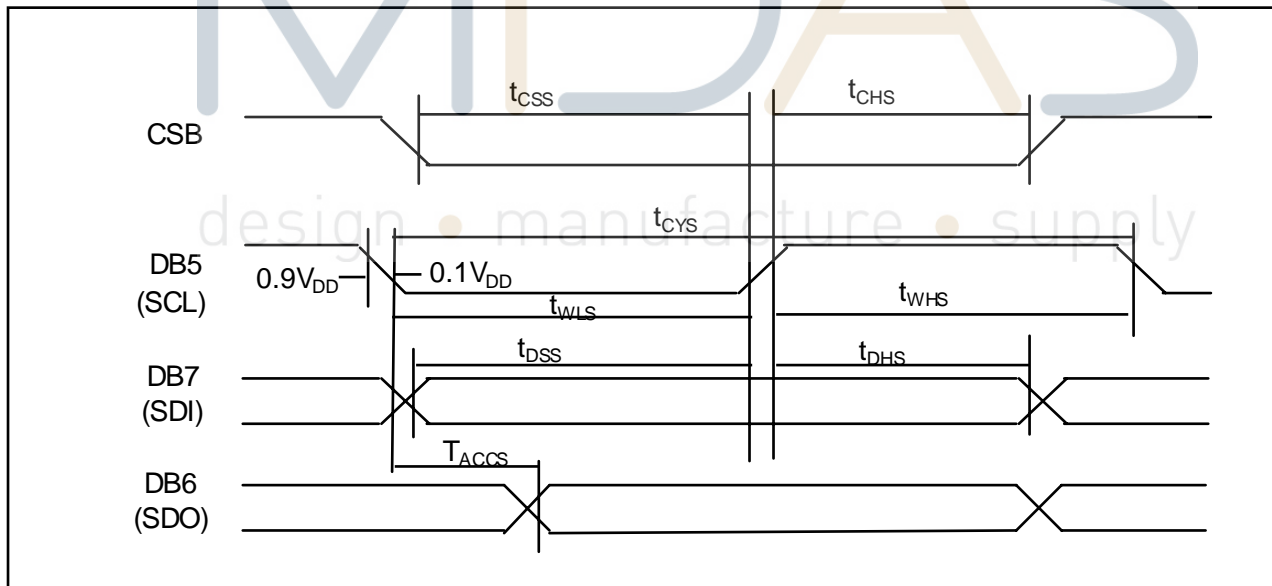

Figure 3. Serial Interface Characteristics

(VDD = 4.7 to 5.3V, Ta = -40 to +85°C)

Item	Signal	Symbol	Min.	Typ.	Max.	Unit	Remark
------	--------	--------	------	------	------	------	--------

Serial clock cycle	DB5 (SCL)	tCYS	250	-	-	ns	
SCL high pulse width		tWHS	100	-	-		
SCL low pulse width		tWLS	100	-	-		
CS1B setup time	CSB	tCSS	150	-	-	ns	
CS1B hold time		tCHS	150	-	-		
Data setup time	DB7 (SDI)	tDSS	100	-	-	ns	
Data hold time		tDHS	100	-	-		
Read access time	DB6 (SDO)	tACCS	-	-	50	ns	

MIDAS

design • manufacture • supply

11. Absolute Maximum Ratings

Item	Symbol	Min	Max	Unit	Notes
Operating Temperature	T_{OP}	-40	+80	°C	
Storage Temperature	T_{ST}	-40	+80	°C	
Input Voltage	V_I	-0.3	VDD	V	
Supply Voltage For Logic	VDD-V _{SS}	-0.3	5.3	V	



12. Electrical Characteristics

Item	Symbol	Condition	Min	Typ	Max	Unit
Supply Voltage For Logic	VDD-VSS	—	3.0	5.0	5.3	V
Input High Volt.	VIH	—	0.9 VDD	—	VDD	V
Input Low Volt.	VIL	—	GND	—	0.1VDD	V
Output High Volt.	VOH	IOH=-0.5mA	0.8 VDD	—	VDD	V
Output Low Volt.	VOL	IOL=0.5mA	GND	—	0.2 VDD	V
Supply Current	IDD	VDD=5V	—	16	—	mA
CIE _x (Yellow)		x,y(CIE1931)	0.44	0.48	0.52	
CIE _y (Yellow)		x,y(CIE1931)	0.46	0.50	0.54	

13. Optical Characteristics

Item	Symbol	Condition	Min	Typ	Max	Unit
View Angle	(V) θ		160			deg
	(H) ϕ		160			deg
Contrast Ratio	CR	Dark	2000:1		—	—
Response Time	T rise	—		10		μ s
	T fall	—		10		μ s
Supply Voltage For Logic 5V 50% Check Board Brightness		With polarizer		125		nits
Supply Voltage For Logic 3V 50% Check Board Brightness		With polarizer		175		nits

14.OLED Lifetime

ITEM	Conditions	Typ	Remark
Operating Life Time	Ta=25°C /Initial 50% CheckBoard brightness 125nits	100,000 Hrs	Note

Notes:

1. Simulation pattern for operation test: interchanging with 50% checkboard
The brightness decay does not exceed 50%.
2. You can use the display off mode to make long life.
3. The average operating lifetime at room temperature is estimated by the accelerated operation at high temperature conditions.



15. Reliability

Content of Reliability Test

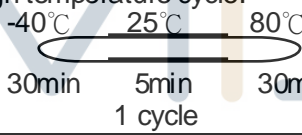
Environmental Test			
Test Item	Content of Test	Test Condition	Applicable Standard
High Temperature storage	Endurance test applying the high storage temperature for a long time.	80°C 240hrs	—
High Temperature Operation	Endurance test applying the electric stress (Voltage & Current) and the thermal stress to the element for a long time.	80°C 240hrs	—
Low Temperature Operation	Endurance test applying the electric stress under low temperature for a long time.	-40°C 240hrs	—
High Temperature/ Humidity Storage	Endurance test applying the high temperature and high humidity storage for a long time.	60°C,90%RH 240hrs	—
Temperature Cycle	Endurance test applying the low and high temperature cycle.  -40°C 25°C 80°C 30min 5min 30min 1 cycle	-40°C/80°C 100 cycles	—
Mechanical Test			
Vibration test	Endurance test applying the vibration during transportation and using.	10~22Hz→1.5mmp-p 22~500Hz→1.5G Total 0.5hrs	—
Shock test	Constructional and mechanical endurance test applying the shock during transportation.	50G Half sign wave 11 msedc 3 times of each direction	—
Atmospheric pressure test	Endurance test applying the atmospheric pressure during transportation by air.	115mbar 40hrs	—
Others			
Static electricity test	Endurance test applying the electric stress to the terminal.	VS=800V,RS=1.5kΩ CS=100pF 1 time	—

***Supply voltage for logic system=5V. Supply voltage for OLED system =Operating voltage at 25°C

Test and measurement conditions

1. All measurements shall not be started until the specimens attain to temperature stability.
After the completion of the described reliability test, the samples were left at room temperature for 2 hrs prior to conducting the failure test at $23\pm 5^{\circ}\text{C}$; $55\pm 15\%$ RH.
2. All-pixels-on is used as operation test pattern.
3. The degradation of Polarizer are ignored for High Temperature storage, High Temperature/ Humidity Storage, Temperature Cycle

Evaluation criteria

1. The function test is OK.
2. No observable defects.
3. Luminance: $> 50\%$ of initial value.
4. Current consumption: within $\pm 50\%$ of initial value.



APPENDIX:

RESIDUE IMAGE

Because the pixels are lighted in different time, the luminance of active pixels may reduce or differ from inactive pixels. Therefore, the residue image will occur. To avoid the residue image, every pixel needs to be lighted up uniformly.

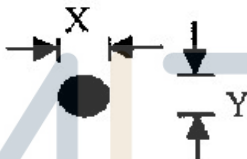

16. Inspection specification

NO	Item	Criterion	AQL													
01	Electrical Testing	1.1 Missing vertical, horizontal segment, segment contrast defect. 1.2 Missing character, dot or icon. 1.3 Display malfunction. 1.4 No function or no display. 1.5 Current consumption exceeds product specifications. 1.6 Viewing angle defect. 1.7 Mixed product types. 1.8 Contrast defect.	0.65													
02	Black or bright spots on OLED (display only)	2.1 Bright and black spots on display $\leq 0.25\text{mm}$, no more than three Bright or black spots present. 2.2 Densely spaced: No more than two spots or lines within 3mm	2.5													
03	Black spots, bright spots, contamination (non-display)	3.1 Round type : As following drawing $\Phi = (x + y) / 2$  <table border="1" data-bbox="901 795 1364 1041"> <thead> <tr> <th>SIZE</th> <th>Acceptable QTY</th> </tr> </thead> <tbody> <tr> <td>$\Phi \leq 0.10$</td> <td>Accept no dense</td> </tr> <tr> <td>$0.10 < \Phi \leq 0.20$</td> <td>2</td> </tr> <tr> <td>$0.20 < \Phi \leq 0.25$</td> <td>1</td> </tr> <tr> <td>$0.25 < \Phi$</td> <td>0</td> </tr> </tbody> </table>	SIZE	Acceptable QTY	$\Phi \leq 0.10$	Accept no dense	$0.10 < \Phi \leq 0.20$	2	$0.20 < \Phi \leq 0.25$	1	$0.25 < \Phi$	0	2.5			
		SIZE	Acceptable QTY													
$\Phi \leq 0.10$	Accept no dense															
$0.10 < \Phi \leq 0.20$	2															
$0.20 < \Phi \leq 0.25$	1															
$0.25 < \Phi$	0															
3.2 Line type : (As following drawing)  <table border="1" data-bbox="742 1086 1364 1265"> <thead> <tr> <th>Length</th> <th>Width</th> <th>Acceptable QTY</th> </tr> </thead> <tbody> <tr> <td>---</td> <td>$W \leq 0.02$</td> <td>Accept no dense</td> </tr> <tr> <td>$L \leq 3.0$</td> <td>$0.02 < W \leq 0.03$</td> <td rowspan="2">2</td> </tr> <tr> <td>$L \leq 2.5$</td> <td>$0.03 < W \leq 0.05$</td> </tr> <tr> <td>---</td> <td>$0.05 < W$</td> <td>As round type</td> </tr> </tbody> </table>	Length	Width	Acceptable QTY	---	$W \leq 0.02$	Accept no dense	$L \leq 3.0$	$0.02 < W \leq 0.03$	2	$L \leq 2.5$	$0.03 < W \leq 0.05$	---	$0.05 < W$	As round type	2.5	
Length	Width	Acceptable QTY														
---	$W \leq 0.02$	Accept no dense														
$L \leq 3.0$	$0.02 < W \leq 0.03$	2														
$L \leq 2.5$	$0.03 < W \leq 0.05$															
---	$0.05 < W$	As round type														
04	Polarizer bubbles	If bubbles are visible, judge using black spot specifications, not easy to find, must check in specify direction.	<table border="1" data-bbox="869 1332 1364 1556"> <thead> <tr> <th>Size Φ</th> <th>Acceptable QTY</th> </tr> </thead> <tbody> <tr> <td>$\Phi \leq 0.20$</td> <td>Accept no dense</td> </tr> <tr> <td>$0.20 < \Phi \leq 0.50$</td> <td>3</td> </tr> <tr> <td>$0.50 < \Phi \leq 1.00$</td> <td>2</td> </tr> <tr> <td>$1.00 < \Phi$</td> <td>0</td> </tr> <tr> <td>Total QTY</td> <td>3</td> </tr> </tbody> </table>	Size Φ	Acceptable QTY	$\Phi \leq 0.20$	Accept no dense	$0.20 < \Phi \leq 0.50$	3	$0.50 < \Phi \leq 1.00$	2	$1.00 < \Phi$	0	Total QTY	3	2.5
Size Φ	Acceptable QTY															
$\Phi \leq 0.20$	Accept no dense															
$0.20 < \Phi \leq 0.50$	3															
$0.50 < \Phi \leq 1.00$	2															
$1.00 < \Phi$	0															
Total QTY	3															

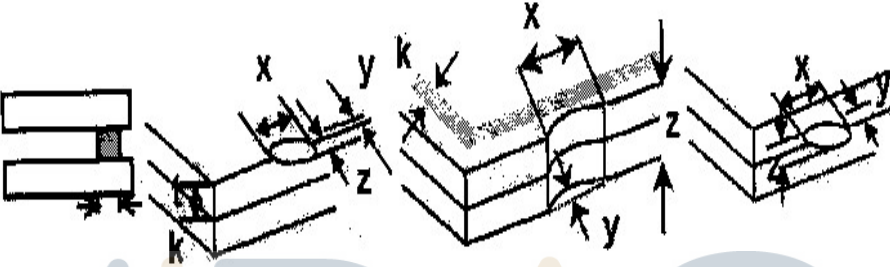
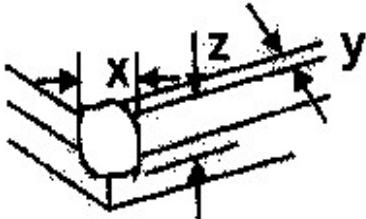
NO	Item	Criterion	AQL																		
05	Scratches	Follow NO.3 black spots, bright spots, contamination																			
06	Chipped glass	<p>Symbols Define: x: Chip length y: Chip width z: Chip thickness k: Seal width t: Glass thickness a: OLED side length L: Electrode pad length:</p> <p>6.1 General glass chip : 6.1.1 Chip on panel surface and crack between panels:</p>  <table border="1" data-bbox="437 987 1177 1207"> <thead> <tr> <th>z Chip thickness</th> <th>y: Chip width</th> <th>x: Chip length</th> </tr> </thead> <tbody> <tr> <td>$Z \leq 1/2t$</td> <td>Not over viewing area</td> <td>$x \leq 1/8a$</td> </tr> <tr> <td>$1/2t < z \leq 2t$</td> <td>Not exceed 1/3k</td> <td>$x \leq 1/8a$</td> </tr> </tbody> </table> <p>⊙ If there are 2 or more chips, x is total length of each chip.</p> <p>6.1.2 Corner crack:</p>  <table border="1" data-bbox="437 1547 1177 1767"> <thead> <tr> <th>z Chip thickness</th> <th>y: Chip width</th> <th>x: Chip length</th> </tr> </thead> <tbody> <tr> <td>$Z \leq 1/2t$</td> <td>Not over viewing area</td> <td>$x \leq 1/8a$</td> </tr> <tr> <td>$1/2t < z \leq 2t$</td> <td>Not exceed 1/3k</td> <td>$x \leq 1/8a$</td> </tr> </tbody> </table> <p>⊙ If there are 2 or more chips, x is the total length of each chip.</p>	z Chip thickness	y: Chip width	x: Chip length	$Z \leq 1/2t$	Not over viewing area	$x \leq 1/8a$	$1/2t < z \leq 2t$	Not exceed 1/3k	$x \leq 1/8a$	z Chip thickness	y: Chip width	x: Chip length	$Z \leq 1/2t$	Not over viewing area	$x \leq 1/8a$	$1/2t < z \leq 2t$	Not exceed 1/3k	$x \leq 1/8a$	2.5
z Chip thickness	y: Chip width	x: Chip length																			
$Z \leq 1/2t$	Not over viewing area	$x \leq 1/8a$																			
$1/2t < z \leq 2t$	Not exceed 1/3k	$x \leq 1/8a$																			
z Chip thickness	y: Chip width	x: Chip length																			
$Z \leq 1/2t$	Not over viewing area	$x \leq 1/8a$																			
$1/2t < z \leq 2t$	Not exceed 1/3k	$x \leq 1/8a$																			

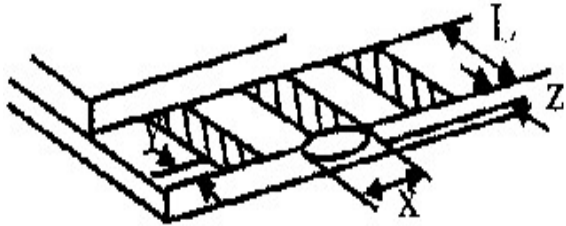
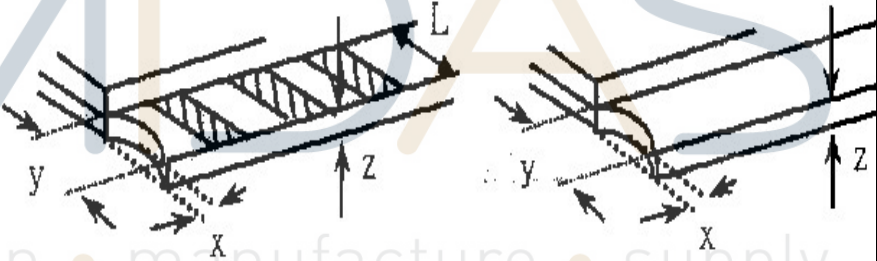
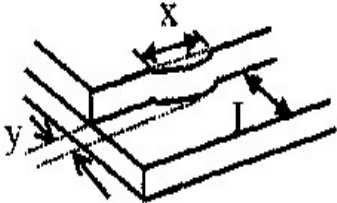

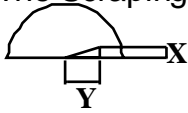
NO	Item	Criterion	AQL								
06	Glass crack	<p>Symbols :</p> <p>x: Chip length y: Chip width z: Chip thickness k: Seal width t: Glass thickness a: OLED side length L: Electrode pad length</p> <p>6.2 Protrusion over terminal :</p> <p>6.2.1 Chip on electrode pad :</p>  <table border="1" data-bbox="443 842 1118 958"> <thead> <tr> <th>y: Chip width</th> <th>x: Chip length</th> <th>z: Chip thickness</th> </tr> </thead> <tbody> <tr> <td>$y \leq 0.5\text{mm}$</td> <td>$x \leq 1/8a$</td> <td>$0 < z \leq t$</td> </tr> </tbody> </table>	y: Chip width	x: Chip length	z: Chip thickness	$y \leq 0.5\text{mm}$	$x \leq 1/8a$	$0 < z \leq t$			
		y: Chip width	x: Chip length	z: Chip thickness							
$y \leq 0.5\text{mm}$	$x \leq 1/8a$	$0 < z \leq t$									
<p>6.2.2 Non-conductive portion:</p>  <table border="1" data-bbox="497 1285 1118 1402"> <thead> <tr> <th>y: Chip width</th> <th>x: Chip length</th> <th>z: Chip thickness</th> </tr> </thead> <tbody> <tr> <td>$y \leq L$</td> <td>$x \leq 1/8a$</td> <td>$0 < z \leq t$</td> </tr> </tbody> </table> <p>⊙ If the chipped area touches the ITO terminal, over 2/3 of the ITO must remain and be inspected according to electrode terminal specifications.</p> <p>⊙ If the product will be heat sealed by the customer, the alignment mark not be damaged.</p> <p>6.2.3 Substrate protuberance and internal crack.</p>  <table border="1" data-bbox="852 1644 1230 1720"> <thead> <tr> <th>y: width</th> <th>x: length</th> </tr> </thead> <tbody> <tr> <td>$y \leq 1/3L$</td> <td>$x \leq a$</td> </tr> </tbody> </table>	y: Chip width	x: Chip length	z: Chip thickness	$y \leq L$	$x \leq 1/8a$	$0 < z \leq t$	y: width	x: length	$y \leq 1/3L$	$x \leq a$	2.5
y: Chip width	x: Chip length	z: Chip thickness									
$y \leq L$	$x \leq 1/8a$	$0 < z \leq t$									
y: width	x: length										
$y \leq 1/3L$	$x \leq a$										

NO	Item	Criterion	AQL
07	Cracked glass	The OLED with extensive crack is not acceptable.	2.5
08	Bezel	8.1 Bezel may not have rust, be deformed or have fingerprints, stains or other contamination. 8.2 Bezel must comply with job specifications.	2.5 0.65
9	PCB、COB	<p>9.1 COB seal may not have pinholes larger than 0.2mm or contamination.</p> <p>9.2 COB seal surface may not have pinholes through to the IC.</p> <p>9.3 The height of the COB should not exceed the height indicated in the assembly diagram.</p> <p>9.4 There may not be more than 2mm of sealant outside the seal area on the PCB. And there should be no more than three places.</p> <p>9.5 No oxidation or contamination PCB terminals.</p> <p>9.6 Parts on PCB must be the same as on the production characteristic chart. There should be no wrong parts, missing parts or excess parts.</p> <p>9.7 The jumper on the PCB should conform to the product characteristic chart.</p> <p>9.8 If solder gets on bezel tab pads, zebra pad or screw hold pad, make sure it is smoothed down.</p> <p>9.9 The Scraping testing standard for Copper Coating of PCB</p>  <p style="text-align: center;">$X * Y \leq 2\text{mm}^2$</p>	2.5 2.5 0.65 2.5 2.5 0.65 0.65 2.5 2.5
10	Soldering	<p>10.1 No un-melted solder paste may be present on the PCB.</p> <p>10.2 No cold solder joints, missing solder connections, oxidation or icide.</p> <p>10.3 No residue or solder balls on PCB.</p> <p>10.4 No short circuits in components on PCB.</p>	2.5 2.5 2.5 0.65

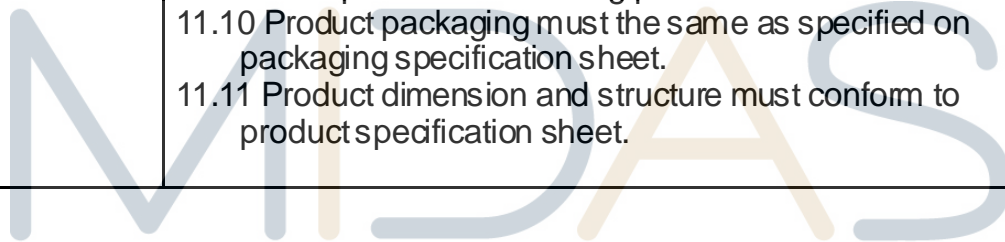
NO	Item	Criterion	AQL
11	General appearance	11.1 No oxidation, contamination, curves or, bends on interface Pin (OLB) of TCP.	2.5
		11.2 No cracks on interface pin (OLB) of TCP.	0.65
		11.3 No contamination, solder residue or solder balls on product.	2.5
		11.4 The IC on the TCP may not be damaged, circuits.	2.5
		11.5 The uppermost edge of the protective strip on the interface pin must be present or look as if it causes the interface pin to sever.	2.5
		11.6 The residual rosin or tin oil of soldering (component or chip component) is not burned into brown or black color.	2.5
		11.7 Sealant on top of the ITO circuit has not hardened.	0.65
		11.8 Pin type must match type in specification sheet.	0.65
		11.9 OLED pin loose or missing pins.	0.65
		11.10 Product packaging must be the same as specified on packaging specification sheet.	0.65
		11.11 Product dimension and structure must conform to product specification sheet.	0.65

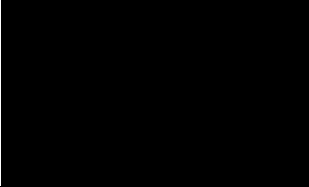
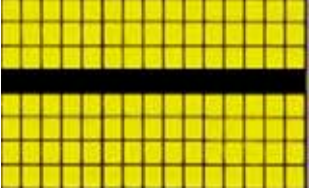

design • manufacture • supply

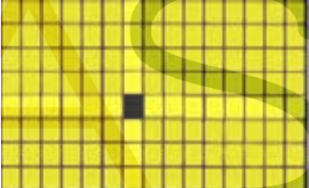
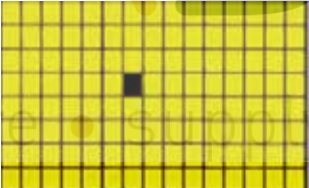
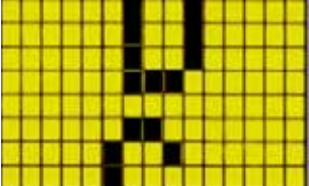
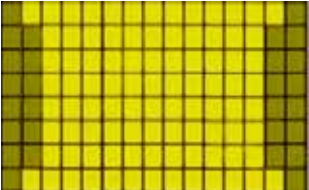
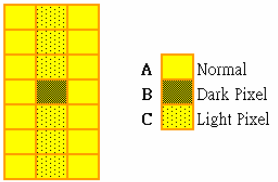
Check Item	Classification	Criteria
No Display	Major	
Missing Line	Major	 
Pixel Short	Major	
Darker Short	Major	
Wrong Display	Major	
Un-uniform $B/A \times 100\% < 70\%$ $A/C \times 100\% < 70\%$	Major	 

17. Precautions in use of Modules

1. Avoid applying excessive shocks to the module or making any alterations or modifications to it.
2. Don't make extra holes on the printed circuit board, modify its shape or change the components of OLED module.
3. Don't disassemble the OLED module.
4. Don't operate it above the absolute maximum rating.
5. Don't drop, bend or twist OLED module.
6. Soldering: only to the I/O terminals.
7. Storage: please storage in anti-static electricity container and clean environment.
8. Midas have the right to change the passive components
(Resistors, capacitors and other passive components will have different appearance and color caused by the different supplier.)
9. Midas have the right to change the PCB Rev.



15.1 Handling Precautions

- (1) Since the display panel is being made of glass, do not apply mechanical impacts such as dropping from a high position.
- (2) If the display panel is broken by some accident and the internal organic substance leaks out, be careful not to inhale nor lick the organic substance.
- (3) If pressure is applied to the display surface or its neighborhood of the OLED display module, the cell structure may be damaged and be careful not to apply pressure to these sections.
- (4) The polarizer covering the surface of the OLED display module is soft and easily scratched. Please be careful when handling the OLED display module.
- (5) When the surface of the polarizer of the OLED display module has soil, clean the surface. It takes advantage of by using following adhesion tape.

* Scotch Mending Tape No. 810 or an equivalent

Never try to breathe upon the soiled surface nor wipe the surface using cloth containing solvent such as ethyl alcohol, since the surface of the polarizer will become cloudy.

Also, pay attention that the following liquid and solvent may spoil the polarizer:

* Water

* Ketone

* Aromatic Solvents

- (6) Hold OLED display module very carefully when placing OLED display module into the System housing. Do not apply excessive stress or pressure to OLED display module. And, do not over bend the film with electrode pattern layouts.

These stresses will influence the display performance. Also, secure sufficient rigidity for the outer cases.

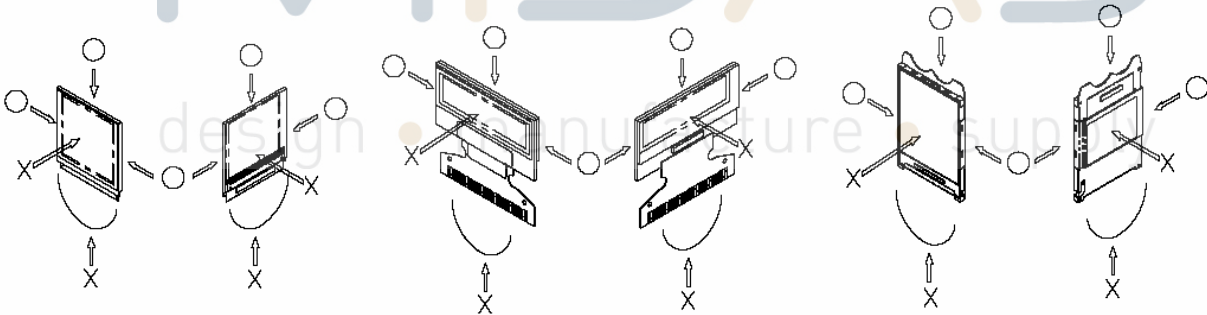

- (7) Do not apply stress to the LSI chips and the surrounding molded sections.
- (8) Do not disassemble nor modify the OLED display module.
- (9) Do not apply input signals while the logic power is off.
- (10) Pay sufficient attention to the working environments when handing OLED display modules to prevent occurrence of element breakage accidents by static electricity.
 - * Be sure to make human body grounding when handling OLED display modules.
 - * Be sure to ground tools to use or assembly such as soldering irons.
 - * To suppress generation of static electricity, avoid carrying out assembly work under dry environments.
 - * Protective film is being applied to the surface of the display panel of the OLED display

module. Be careful since static electricity may be generated when exfoliating the protective film.

(11) Protection film is being applied to the surface of the display panel and removes the protection film before assembling it. At this time, if the OLED display module has been stored for a long period of time, residue adhesive material of the protection film may remain on the surface of the display panel after removed of the film. In such case, remove the residue material by the method introduced in the above Section 5.

(12) If electric current is applied when the OLED display module is being dewed or when it is placed under high humidity environments, the electrodes may be corroded and be careful to avoid the above.

8.2 Storage Precautions

(1) When storing OLED display modules, put them in static electricity preventive bags avoiding exposure to direct sun light nor to lights of fluorescent lamps. and, also, avoiding high temperature and high humidity environment or low temperature (less than 0°C) environments.

(We recommend you to store these modules in the packaged state when they were shipped from Midas Components Ltd.

At that time, be careful not to let water drops adhere to the packages or bags nor let dewing occur with them.

(2) If electric current is applied when water drops are adhering to the surface of the OLED display module, when the OLED display module is being dewed or when it is placed under high humidity environments, the electrodes may be corroded and be careful about the above.

8.3 Designing Precautions

(1) The absolute maximum ratings are the ratings which cannot be exceeded for OLED display module, and if these values are exceeded, panel damage may be happen.

(2) To prevent occurrence of malfunctioning by noise, pay attention to satisfy the VIL and VIH specifications and, at the same time, to make the signal line cable as short as possible.

(3) We recommend you to install excess current preventive unit (fuses, etc.) to the power circuit (VDD). (Recommend value: 0.5A)

(4) Pay sufficient attention to avoid occurrence of mutual noise interference with the neighboring devices.

(5) As for EMI, take necessary measures on the equipment side basically.

(6) When fastening the OLED display module, fasten the external plastic housing section.

(7) If power supply to the OLED display module is forcibly shut down by such errors as taking out the main battery while the OLED display panel is in operation, we cannot guarantee the quality of this OLED display module.

Connection (contact) to any other potential than the above may lead to rupture of the IC.