



design • manufacture • supply

Midas Components Limited
Electra House
32 Southtown Road
Great Yarmouth
Norfolk
NR31 0DU
England

Telephone
Fax
Email
Website

+44 (0)1493 602602
+44 (0)1493 665111
sales@midasdisplays.com
www.midasdisplays.com

Specification	
Part Number:	MCOB21605GX-EBP
Version:	
Date:	



design • manufacture • supply

Content

- Coding system3
- Mechanical Specification4
- Mechanical Drawing.....5
- Pin Description.....6
- DC Characteristics7
- Optical Characteristics7
- Electrical Absolute Ratings8
- POWER SUPPLY8
- Application9
- SSD1311 CGROM CHARACTER CODE.....11



Midas Displays OLED Part Number System

MCO	B	21605	A	*	V	-	E	W	I	*		
1	2	3	4	5	6		7	8	9	10		
1	=	MCO:	Midas Displays OLED									
2	=	Blank:	B: COB (Chip on Board) T: TAB (Taped Automated Bonding)									
3	=	No of dots:	(e.g. 240064 = 240 x 64 dots)				(e.g. 21605 = 2 x 16 5mm C.H.)					
4	=	Series	A to Z									
5	=	Series Variant:	A to Z and 1 to 9 – see addendum									
6	=	Operating Temp Range:	A: -30+85° C		V: -40+80° C		Y: -40 +70° C		Z: -30+70° C			
			X: -40 +85° C									
7	=	Character Set:	Blank: Not Applicable E: Multi European Font Set (English/Japanese – Western European (K) – Cyrillic (R))									
8	=	Colour:	Y: Yellow		W: White		B: Blue		R: Red		G: Green	RGB: Full Colour
9	=	Interface:	P: Parallel		I: I ² C		S: SPI		M: Multi			
10	=	Voltage Variant:	e.g. 3 = 3v									

Functions and Features

- 2 lines x 16 characters
- Built-in controller
- Parallel or serial MPU interface (Default 6800 MPU parallel)
- +2.8V ~ +5.3V Power Supply
- viewing angle “Free”
- Wide Temperature -40°C ~ +80°C (Operating)
- Sunlight Readable Technology
- RoHS compliant

Mechanical Specification

Item	Description	
Product No.	ΑΠΡΟΤΥΠΟ	
Viewing Area	58.22(W)×13.52(H)	mm
Module Size	80.0(W)×36.0(H)×9.1 (D)	mm
Dot Size	0.57(W)×0.67(H)	mm
Dot Pitch	0.60(W)×0.70(H)	mm
Display Format	16 characters (W)×2 lines (H)	
Duty Ratio	1/16	Duty
Controller	SSD1311 or Equivalent	
Interface	6800 (Default) 8Bit 8080 (Option) SPI (Option) I2C (Option)	

Mechanical Drawing

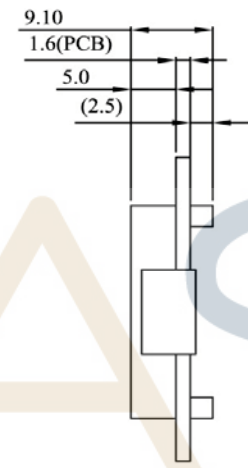
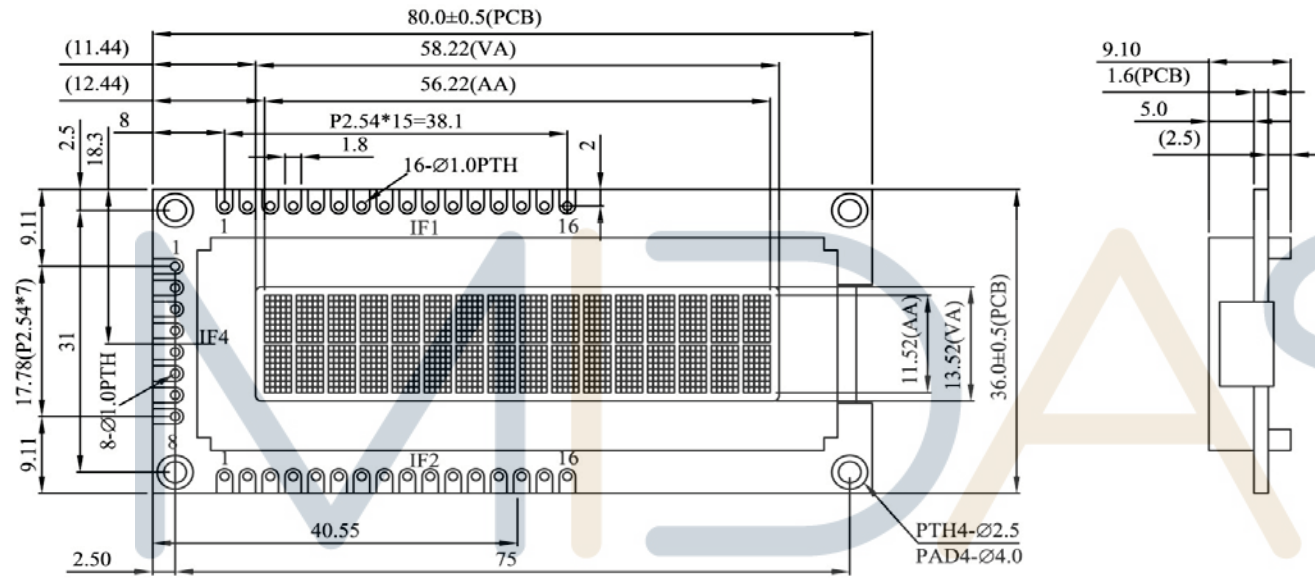

IF1,IF2	SYMBOL
1	VSS
2	VDD
3	Vo
4	RS
5	R/W#
6	E
7-14	DB0-7
15-16	NC

design • manufacture • supply

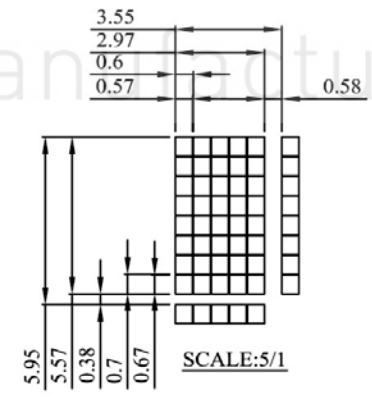

Pin Description

Parallel Interface (default):

Pin No.	Symbol	External Connection	Description
1	VSS	Power Supply	Ground
2	VDD	Power Supply	Supply Voltage for OLED and logic
3	Vo	-	Contrast Adjustment
4	RS(D/C#)	MPU	Register select signal. H: DATA, L: Command
5	RW# (WR#)	MPU	6800-interface: Read/Write select signal, R/W=1: Read R/W: =0: Write 8080-interface: Active LOW Write signal.
6	E or /RD	MPU	6800-interface: Operation enable signal. Falling edge triggered. 8080-interface: Active LOW Read signal.
7-14	DB0~DB7	MPU	8-bit Bi-directional data bus lines
15-16	NC	-	No Connect

DC Characteristics

Item	Symbol	Condition	Min.	Type	Max.	Unit
Power Supply for Logic	VDD	(Wide Voltage I/O Application)	2.8	5.0	5.3	Volt
Input Voltage for I/O Pins	V _i	(Wide Voltage I/O Application)	2.8	5.0	5.3	Volt
Input Voltage	V _{IL}	L level	0	-	0.2 VDD	Volt
Input Voltage	V _{IH}	H level	0.8 VDD	-	VDD	Volt
Output Voltage	V _{OL}	L level	0	-	0.1 VDD	
Output Voltage	V _{OH}	H level	0.9 VDD	-	VDD	
Power Supply Current for OLED	I _{DD}	Note	-	30		mA
Sleep Mode Current for VDD	I _{DD,SLEEP}			1	10	μA

Note:

VDD = 5.0V, 25% Display Area Turn on. 100 cd/m²

When random texts pattern is running, averagely, about 1/4 of pixels will be on.

Optical Characteristics

Item	Symbol	Min.	Typ	Max.	Unit
Viewing angle range			Free		Degree
Dark Room Contrast	Cr		>10,000:1		
Brightness	Lbr		140		cd/m ²
Peak Emission Wavelength	C.I.E 1931	X=0.12 Y=0.22	X=0.16 Y=0.26	X=0.20 Y=0.30	

Electrical Absolute Ratings

Item	Symbol	Min.	Typ.	Max.	Unit	Notes
Power Supply for Logic	VDD	-0.3	5.0	5.5	Volt	1,2
Input Voltage for I/O Pins	VI	-0.3	5.0	5.5	Volt	1,2
Life Time (100 cd/m ²)		---	70,000	---	Hours	3

Note 1: All the above voltages are on the basis of "VSS = 0V".

Note 2: When this module is used beyond the above absolute maximum ratings, permanent breakage of the module may occur.

Note 3: Ta = 25°C, 25% Checkerboard.

Software configuration follows Section ACTUAL APPLICATION EXAMPLE Initialization. End of lifetime is specified as 50% of initial brightness reached. The average operating lifetime at room temperature is estimated by the accelerated operation at high temperature conditions.

POWER SUPPLY

Adjust Brightness by Software & Hardware(VR)

Adjust Brightness by Software(Only)

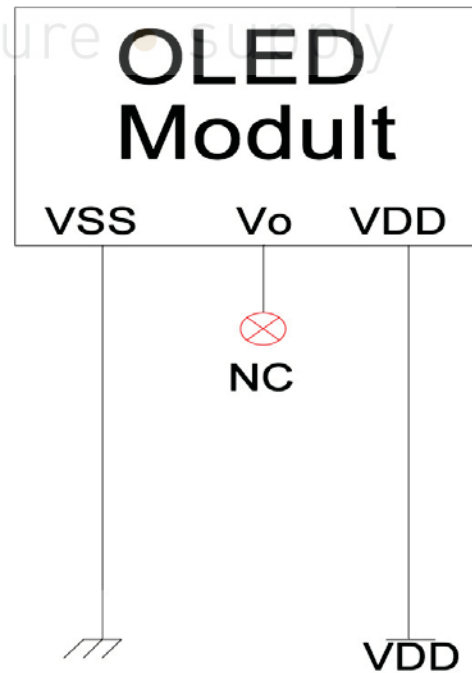
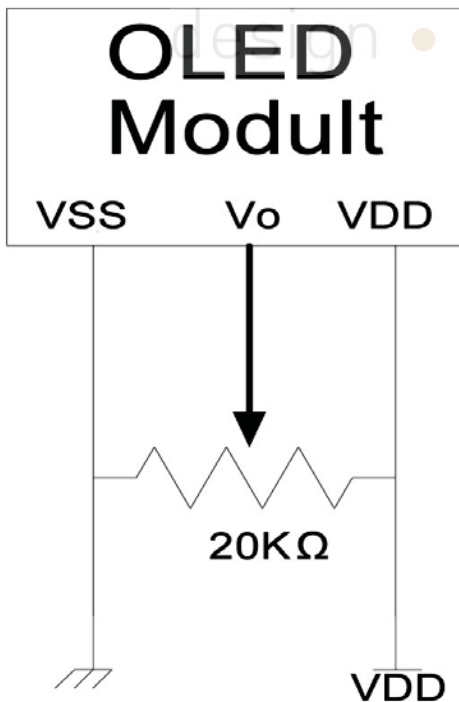

Application

Power up Sequence

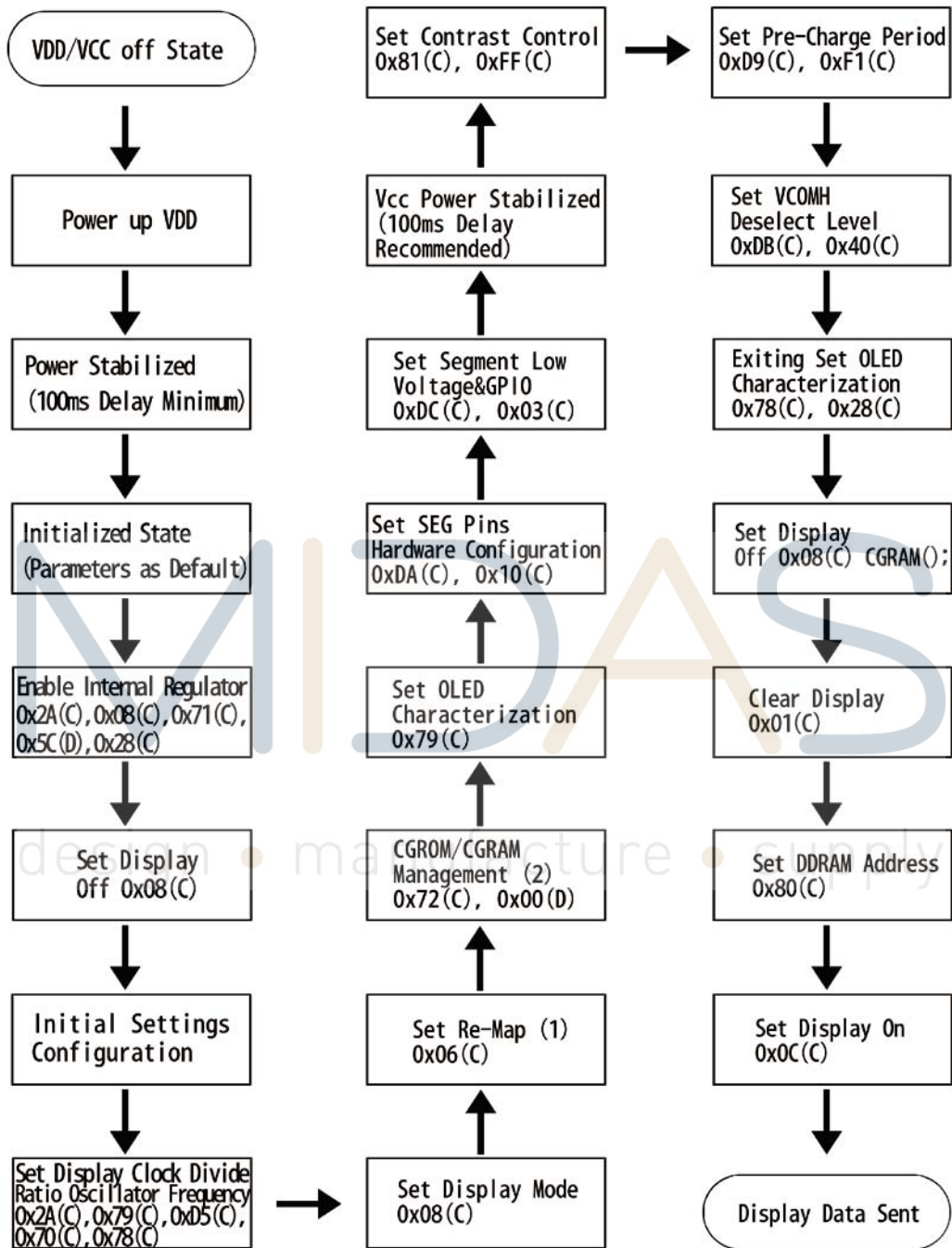

(1) This command could be programmable or defined by pin configuration.

(2) This command could be programmable or defined by pin configuration.

※ (C) : Write Command ※ (D) : Write Data

If the noise is accidentally occurred at the displaying window during the operation, please reset the display in order to recover the display function.

Power down Sequence

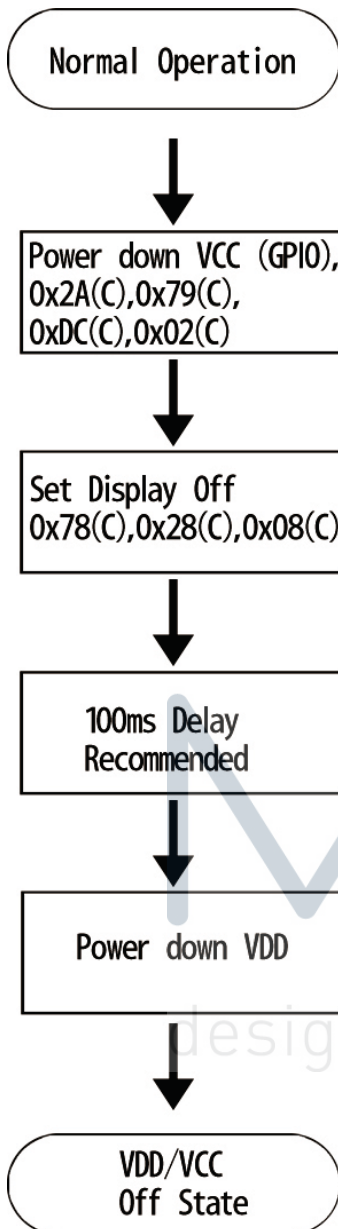

Entering Sleep Mode

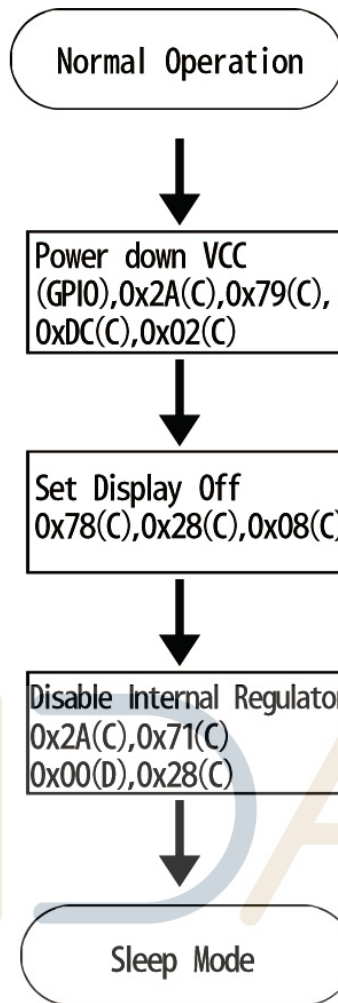

Exiting Sleep Mode

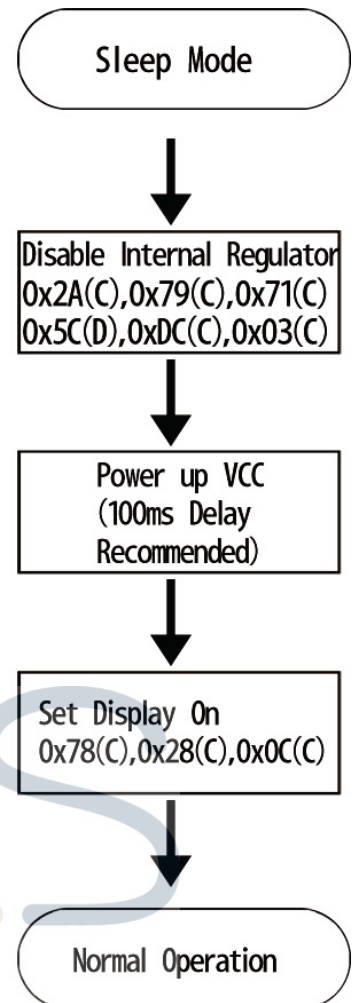

SSD1311 CGROM CHARACTER CODE

ROM A

b7-4 \ b3-0	0000	0001	0010	0011	0100	0101	0110	0111	1000	1001	1010	1011	1100	1101	1110	1111
0000																
0001	☒	☒	☒	☒	☒	☒	☒	☒	☒	☒	☒	☒	☒	☒	☒	☒
0010		!	"	#	\$	%	&	'	()	*	+	,	-	.	/
0011	0	1	2	3	4	5	6	7	8	9	*	*	<	=	>	?
0100	I	A	B	C	D	E	F	G	H	I	J	K	L	M	N	O
0101	P	Q	R	S	T	U	V	W	X	Y	Z	A	B	C	D	E
0110	a	b	c	d	e	f	g	h	i	j	k	l	m	n	o	p
0111	q	r	s	t	u	v	w	x	y	z	A	B	C	D	E	F
1000	0	1	2	3	4	5	6	7	8	9	*	*	<	=	>	?
1001	☒	☒	☒	☒	☒	☒	☒	☒	☒	☒	☒	☒	☒	☒	☒	☒
1010	☒	☒	☒	☒	☒	☒	☒	☒	☒	☒	☒	☒	☒	☒	☒	☒
1011	☒	☒	☒	☒	☒	☒	☒	☒	☒	☒	☒	☒	☒	☒	☒	☒
1100	☒	☒	☒	☒	☒	☒	☒	☒	☒	☒	☒	☒	☒	☒	☒	☒
1101	☒	☒	☒	☒	☒	☒	☒	☒	☒	☒	☒	☒	☒	☒	☒	☒
1110	☒	☒	☒	☒	☒	☒	☒	☒	☒	☒	☒	☒	☒	☒	☒	☒
1111	☒	☒	☒	☒	☒	☒	☒	☒	☒	☒	☒	☒	☒	☒	☒	☒

ROM B

b7-4	b3-0															
	0000	0001	0010	0011	0100	0101	0110	0111	1000	1001	1010	1011	1100	1101	1110	1111
0000																
0001	▲	◆	■	♣	♠	♣	♠	♣	♠	♣	♠	♣	♠	♣	♠	♣
0010	!	"	#	\$	%	&	'	()	*	+	,	-	.	/	
0011	0	1	2	3	4	5	6	7	8	9	:	;	<	=	>	?
0100	Ⓐ	Ⓑ	Ⓒ	Ⓓ	Ⓔ	Ⓕ	Ⓖ	Ⓗ	Ⓘ	Ⓢ	Ⓣ	Ⓚ	Ⓛ	Ⓜ	Ⓝ	Ⓞ
0101	Ⓟ	Ⓠ	Ⓡ	Ⓢ	Ⓣ	Ⓤ	Ⓥ	Ⓦ	Ⓧ	Ⓨ	Ⓩ	Ⓨ	Ⓩ	Ⓨ	Ⓩ	Ⓨ
0110	Ⓛ	Ⓜ	Ⓝ	Ⓞ	Ⓟ	Ⓠ	Ⓡ	Ⓢ	Ⓣ	Ⓤ	Ⓥ	Ⓦ	Ⓧ	Ⓨ	Ⓩ	Ⓨ
0111	Ⓟ	Ⓠ	Ⓡ	Ⓢ	Ⓣ	Ⓤ	Ⓥ	Ⓦ	Ⓧ	Ⓨ	Ⓩ	Ⓨ	Ⓩ	Ⓨ	Ⓩ	Ⓨ
1000	Ⓐ	Ⓑ	Ⓒ	Ⓓ	Ⓔ	Ⓕ	Ⓖ	Ⓗ	Ⓘ	Ⓢ	Ⓣ	Ⓚ	Ⓛ	Ⓜ	Ⓝ	Ⓞ
1001	Ⓟ	Ⓠ	Ⓡ	Ⓢ	Ⓣ	Ⓤ	Ⓥ	Ⓦ	Ⓧ	Ⓨ	Ⓩ	Ⓨ	Ⓩ	Ⓨ	Ⓩ	Ⓨ
1010	Ⓐ	Ⓑ	Ⓒ	Ⓓ	Ⓔ	Ⓕ	Ⓖ	Ⓗ	Ⓘ	Ⓢ	Ⓣ	Ⓚ	Ⓛ	Ⓜ	Ⓝ	Ⓞ
1011	Ⓐ	Ⓑ	Ⓒ	Ⓓ	Ⓔ	Ⓕ	Ⓖ	Ⓗ	Ⓘ	Ⓢ	Ⓣ	Ⓚ	Ⓛ	Ⓜ	Ⓝ	Ⓞ
1100	Ⓐ	Ⓑ	Ⓒ	Ⓓ	Ⓔ	Ⓕ	Ⓖ	Ⓗ	Ⓘ	Ⓢ	Ⓣ	Ⓚ	Ⓛ	Ⓜ	Ⓝ	Ⓞ
1101	Ⓐ	Ⓑ	Ⓒ	Ⓓ	Ⓔ	Ⓕ	Ⓖ	Ⓗ	Ⓘ	Ⓢ	Ⓣ	Ⓚ	Ⓛ	Ⓜ	Ⓝ	Ⓞ
1110	Ⓐ	Ⓑ	Ⓒ	Ⓓ	Ⓔ	Ⓕ	Ⓖ	Ⓗ	Ⓘ	Ⓢ	Ⓣ	Ⓚ	Ⓛ	Ⓜ	Ⓝ	Ⓞ
1111	Ⓐ	Ⓑ	Ⓒ	Ⓓ	Ⓔ	Ⓕ	Ⓖ	Ⓗ	Ⓘ	Ⓢ	Ⓣ	Ⓚ	Ⓛ	Ⓜ	Ⓝ	Ⓞ

ROM C

b7-4	b3-0															
	0000	0001	0010	0011	0100	0101	0110	0111	1000	1001	1010	1011	1100	1101	1110	1111
0000	0	1	2	3	4	5	6	7	8	9	0	1	2	3	4	5
0001	6	7	8	9	A	B	C	D	E	F	G	H	I	J	K	L
0010	.	!	"	#	\$	%	&	'	()	*	+	,	-	.	/
0011	0	1	2	3	4	5	6	7	8	9	*	+	<	=	>	?
0100	a	b	c	d	e	f	g	h	i	j	k	l	m	n	o	
0101	p	q	r	s	t	u	v	w	x	y	z	[\]	^	_
0110	\	a	b	c	d	e	f	g	h	i	j	k	l	m	n	o
0111	p	q	r	s	t	u	v	w	x	y	z	[\]	^	_
1000	0	1	2	3	4	5	6	7	8	9	0	1	2	3	4	5
1001	6	7	8	9	A	B	C	D	E	F	G	H	I	J	K	L
1010	.	!	"	#	\$	%	&	'	()	*	+	,	-	.	/
1011	0	1	2	3	4	5	6	7	8	9	*	+	<	=	>	?
1100	0	1	2	3	4	5	6	7	8	9	0	1	2	3	4	5
1101	6	7	8	9	A	B	C	D	E	F	G	H	I	J	K	L
1110	.	!	"	#	\$	%	&	'	()	*	+	,	-	.	/
1111	0	1	2	3	4	5	6	7	8	9	0	1	2	3	4	5