

### Getting started with X-NUCLEO-NFC02A1 dynamic NFC/RFID tag IC expansion board based on M24LR04E-R for STM32 Nucleo

#### Introduction

The X-NUCLEO-NFC02A1 is a dynamic NFC/RFID tag IC expansion board based on M24LR04E-R to allow expansion of STM32 Nucleo boards.

M24LR04E-R is an NFC Type V/RFID tag IC with a dual interface 4 KBit Electrically Erasable Programmable Read-Only Memory (EEPROM) that also features an I2C interface. It can be operated either from an external power supply, or directly powered by the received carrier electromagnetic field.

X-NUCLEO-NFC02A1 is compatible with the Arduino™ UNO R3 connector pin assignment and can readily be plugged onto any STM32 Nucleo board. Various expansion boards can be easily stacked to allow evaluation of different devices operating together with the dynamic NFC TAG.

The board, shown in [Figure 1](#), features:

- On-board M24LR04E-R NFC Type V/RFID tag IC
- Copper etched double layer 30 mm \* 30 mm PCB Antenna
- Selectable power supply: the board is either powered from the STM32 Nucleo Board or self-powered.
- 3 general purpose LEDs

**Figure 1. Expansion board based on M24LR04E-R for STM32 Nucleo**



# Contents

- 1      Getting started ..... 5**
  - 1.1    Hardware requirements ..... 5
  - 1.2    System requirements ..... 5
  - 1.3    Setting up the board ..... 5
  
- 2      Hardware description ..... 6**
  - 2.1    X-NUCLEO-NFC02A1 board ..... 6
  - 2.2    Power Supply and GPIO options ..... 7
    - 2.2.1    Power Supply option ..... 7
    - 2.2.2    GPIO options ..... 7
  - 2.3    X-NUCLEO-NFC02A1 assembly drawing ..... 8
  
- 3      Component description ..... 9**
  
- 4      Block diagram and hardware schematics ..... 10**
  
- 5      Bill of materials (BOM) ..... 12**
  
- 6      Federal Communications Commission (FCC) and  
Industry Canada (IC) Compliance Statements ..... 14**
  - 6.1    FCC Compliance Statement ..... 14
    - 6.1.1    Part 15.19 ..... 14
    - 6.1.2    Part 15.105 ..... 14
    - 6.1.3    Part 15.21 ..... 14
  - 6.2    Formal notices required by the Industry Canada ..... 14
    - 6.2.1    Compliance Statement ..... 14
    - 6.2.2    Déclaration de conformité ..... 14
  
- 7      Revision history ..... 16**

## List of tables

Table 1.	Interconnections between STM32 Nucleo board and X-NUCLEO-NFC02A1 (left side) . . .	6
Table 2.	Interconnections between STM32 Nucleo board and X-NUCLEO-NFC02A1 (right side) . .	7
Table 3.	M24LR04E-R details . . . . .	9
Table 4.	BOM . . . . .	12
Table 5.	Document revision history . . . . .	16

## List of figures

Figure 1.	Expansion board based on M24LR04E-R for STM32 Nucleo . . . . .	1
Figure 2.	Top assembly view . . . . .	8
Figure 3.	Functional block diagram . . . . .	10
Figure 4.	STM32 Nucleo connectors . . . . .	10
Figure 5.	M24LR04E-R section . . . . .	11
Figure 6.	LEDs and power supply selection . . . . .	11

# 1 Getting started

This section describes the hardware requirements for the X-NUCLEO-NFC02A1 expansion board for STM32 Nucleo.

## 1.1 Hardware requirements

The X-NUCLEO-NFC02A1 is an expansion board to be used with STM32 Nucleo boards. To operate correctly, the X-NUCLEO-NFC02A1 must be connected to the STM32 Nucleo board.

The STM32 Nucleo firmware and the related documentation are available on [www.st.com](http://www.st.com).

The interconnection between the STM32 Nucleo and the X-NUCLEO-NFC02A1 is designed so that any STM32 Nucleo board can be used. Complete testing has been performed on the NUCLEO-L053R8 (based on the ultra-low power STM32L053R8), and the NUCLEO-F401RE (hosting the dynamically efficient STM32F401RE).

## 1.2 System requirements

To use the STM32 Nucleo boards with the X-NUCLEO-NFC02A1 expansion board and to install the board firmware package (order code: X-CUBE-NFC2) the user needs

- a PC with Keil<sup>®</sup>, IAR<sup>™</sup> or Keil<sup>®</sup> AC6 Embedded Development Tool
- a USB type A to Mini-B USB cable to connect the STM32 Nucleo board to the PC

The X-CUBE-NFC2 firmware and the related documentation are available on [www.st.com](http://www.st.com).

The microcontroller on the STM32 Nucleo board must be programmed. For further information about usage of STM32 Nucleo board, refer to user manuals UM1724 and UM1725, available on [www.st.com](http://www.st.com).

## 1.3 Setting up the board

To set up the board, perform the following steps:

1. Check that the jumper on the ST1 connector X-NUCLEO-NFC02A1 is in place. This jumper provides the required voltage to the device on the board
2. Connect the X-NUCLEO-NFC02A1 on the STM32 Nucleo board from the top
3. Power the STM32 Nucleo board using the Mini-B USB cable
4. Program the firmware in the STM32 on the Nucleo board using the provide example
5. Reset the MCU board using the reset button available on the STM32 Nucleo board
6. The kit is ready to be used

## 2 Hardware description

This section describes the X-NUCLEO-NFC02A1 features and provides useful information to understand the board schematic diagrams.

### 2.1 X-NUCLEO-NFC02A1 board

The board allows the user to test the functionality of the M24LR04E-R device, a Dynamic NFC/RFID tag IC with a dual-interface EEPROM. It features an I2C interface and can be operated from a VCC power supply. It is also a contactless memory powered by the received carrier electromagnetic wave.

The M24LR04E-R is organized as 512 × 8 bits in the I2C mode and as 128 × 32 bits in RF mode. The M24LR04E-R also features an energy harvesting analog output, as well as a user-configurable digital output pin toggling during either RF write in progress or RF busy mode.

The M24LR04E-R provides an Energy Harvesting mode on the analog output pin Vout.

When the Energy Harvesting mode is activated, the M24LR04E-R can output the excess energy coming from the RF field on the Vout analog pin. In case the RF field strength is insufficient or when Energy Harvesting mode is disabled, the analog output pin Vout goes into high-Z state and Energy Harvesting mode is automatically stopped.

The M24LR04E-R also features an user configurable open drain output pin toggling during either during RF Write in Progress or RF Busy.

These functionalities can be exploited using the firmware package X-CUBE-NFC2.

The X-NUCLEO-NFC02A1 expansion board and the STM32 Nucleo board are connected through connectors CN1, CN2, CN3 and CN4 (see [Table 1](#) and [Table 2](#) for details).

**Table 1. Interconnections between STM32 Nucleo board and X-NUCLEO-NFC02A1 (left side)**

Signal name	NC	IOREF	RESET	3V3	5V	GND	GND	VIN	A0	A1	A2	A3	A4	A5
Connector name	CN2 Power								CN3 Analog					
Pin number	1	2	3	4	5	6	7	8	1	2	3	4	5	6
NUCLEO-L053R8 (MCU port)	-	-	-	-	-	-	-	-	PA0	PA1	PA4	PB0	PC1/PB9	PC0/PB8
X-NUCLEO-NFC02A1 Expansion board	-	3V3	-	3V3	-	GND	GND	-	-	-	-	-	-	-

**Table 2. Interconnections between STM32 Nucleo board and X-NUCLEO-NFC02A1 (right side)**

Signal name	D15	D14	AREF	GND	D13	D12	D11	D10	D9	D8	D7	D6	D5	D4	D3	D2	D1	D0
Connector name	CN1 Digital										CN4 Digital							
Pin number	10	9	8	7	6	5	4	3	2	1	8	7	6	5	4	3	2	1
NUCLEO-L053R8 (MCU port)	PB8	PB9	-	-	PA5	PA6	PA7	PB8	PC7	PA9	PA8	PB10	PB4	PB5	PB3	PA10	PA2	PA3
X-NUCLEO-NFC02A1 Expansion board	M24LR_SCL	M24LR_SDA	-	GND	-	M24LR_WIP/BUSY (opt)	-	-	-	-	-	-	MCU_LED1	MCU_LED2	MCU_LED3	-	-	-

## 2.2 Power Supply and GPIO options

### 2.2.1 Power Supply option

The X-NUCLEO-NFC02A1 board contains the M24LR04E chip. In addition to basic functionalities (NFC & I2C) of this dynamic NFC/RFID tag IC, some jumpers on board permit to configure extra features.

- ST1: selects the M24LR power source: external (Nucleo Board power supply) or M24LR energy harvesting
- ST2: M24LR energy harvesting is used to power Nucleo STM32 board.

If this feature is used, user has to make sure that the Nucleo STM32 board can accommodate this power configuration (SB2&SB12 removed).

### 2.2.2 GPIO options

The M24LR\_WIP/BUSY optional signal can be disconnected from the Nucleo STM32 Board by removing R1 resistor.

The same option applies to the lines driving the 3 general purpose LEDs (MCU\_LED1, MCU\_LED2 and MCU\_LED3), that can be dedicated to other purposes (by removing, respectively, R2, R3 and R4).

Refer to the schematic diagrams for details.

In case these connections are modified the firmware must be updated to enable proper use of the STM32 resources.

## 2.3 X-NUCLEO-NFC02A1 assembly drawing

Figure 2 shows the components on the X-NUCLEO-NFC02A1 board.

Figure 2. Top assembly view

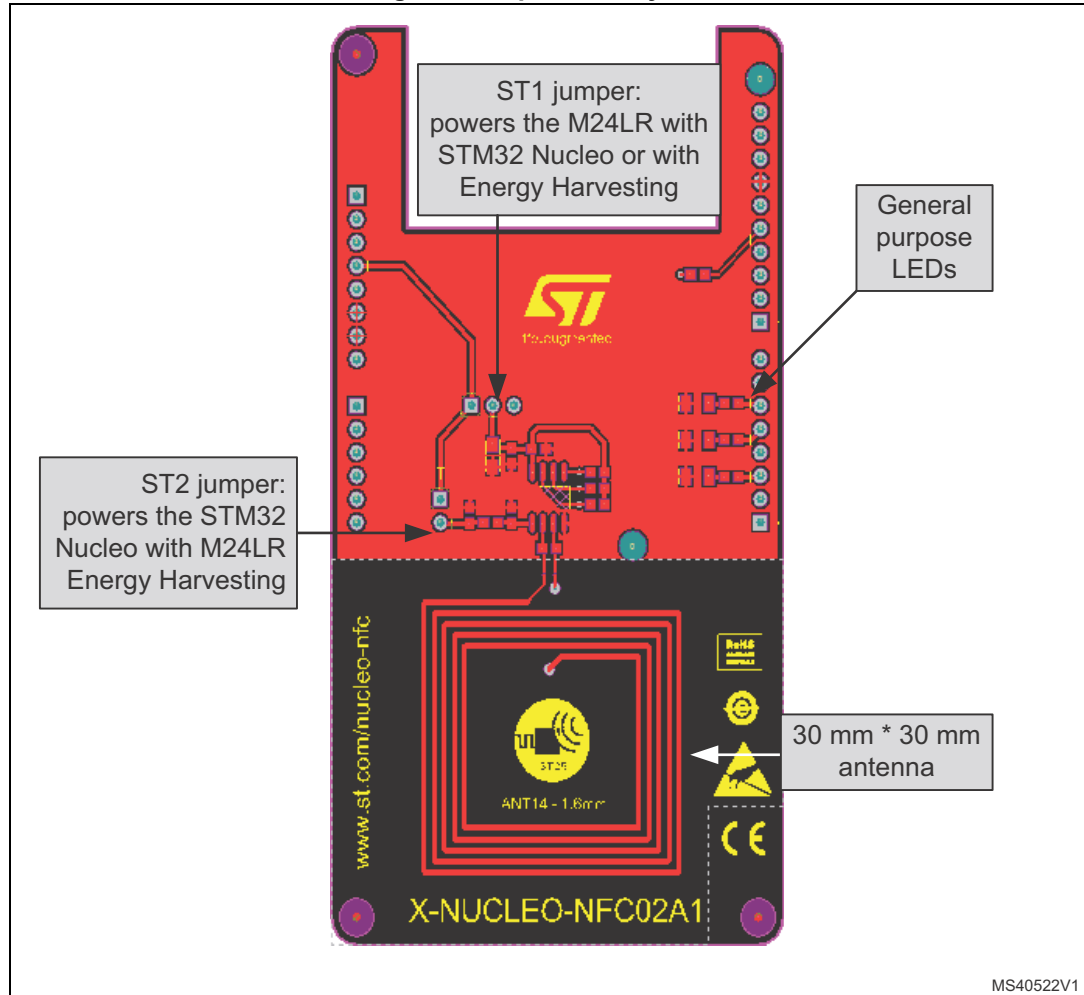



### 3 Component description

The main component on the board is the M24LR04E-R, a dynamic NFC Tag Type V, featuring a 4 Kbit EEPROM, an energy harvesting solution and a configurable open drain output to indicate either RF write in progress or RF busy mode.

The communication between the device and the STM32 Nucleo boards is through I2C interface, and, optionally, through a GPIO for M24LR\_WIP/BUSY signal.

The configuration used to develop this application is detailed in [Table 3](#).

**Table 3. M24LR04E-R details**

Feature	Description
Sales type	M24LR04E-R6MNT/2
Package	SO8N
Operating voltage	1.8 to 5.5 Volts

# 4 Block diagram and hardware schematics

Figure 3. Functional block diagram

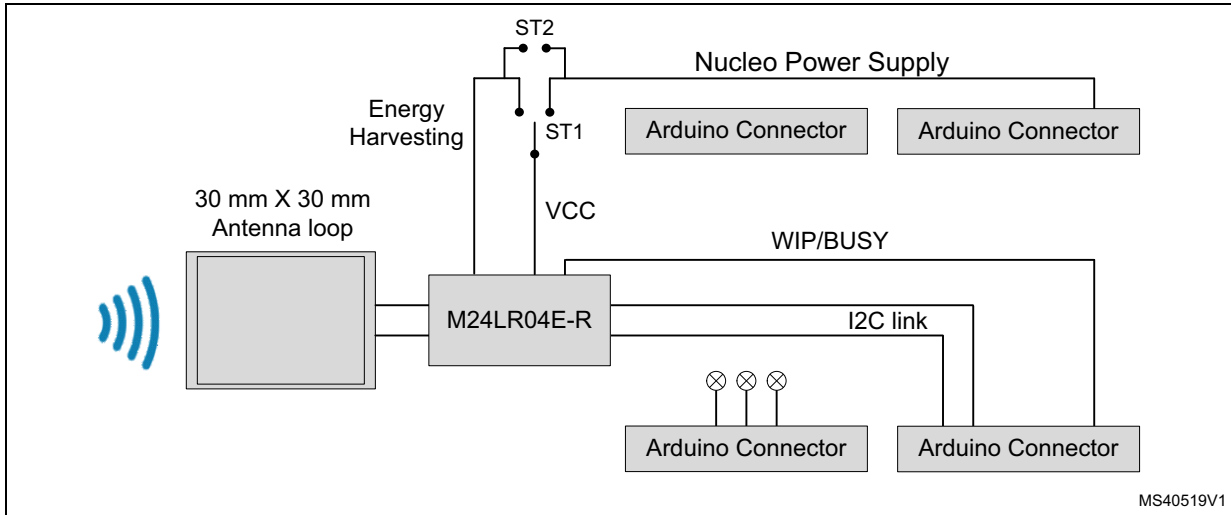

Figure 4. STM32 Nucleo connectors

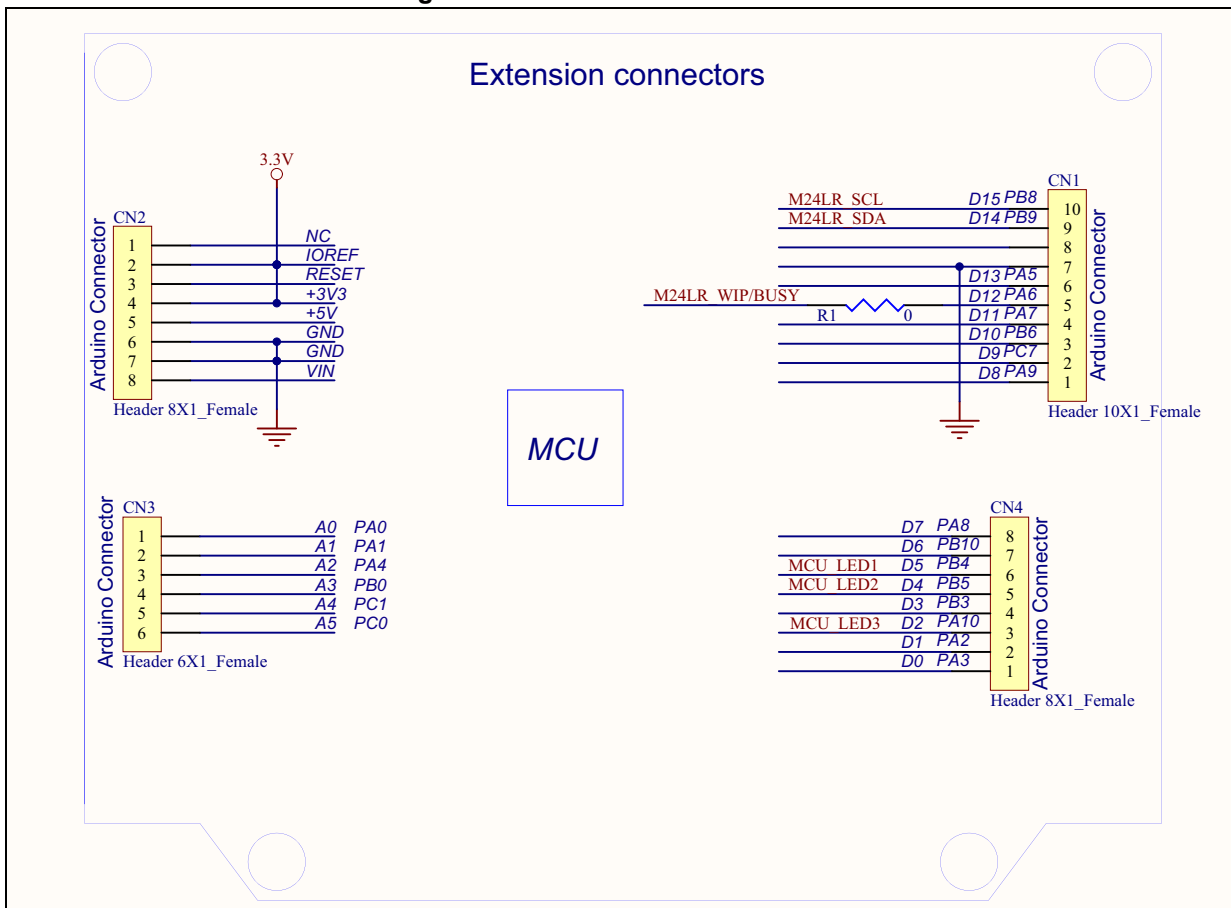

Figure 5. M24LR04E-R section

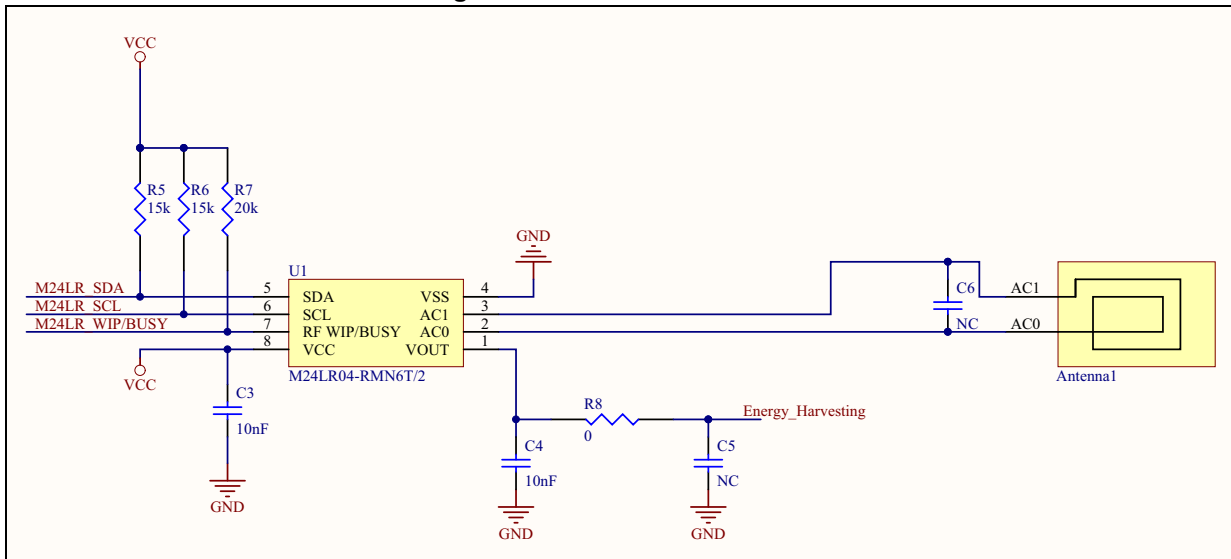
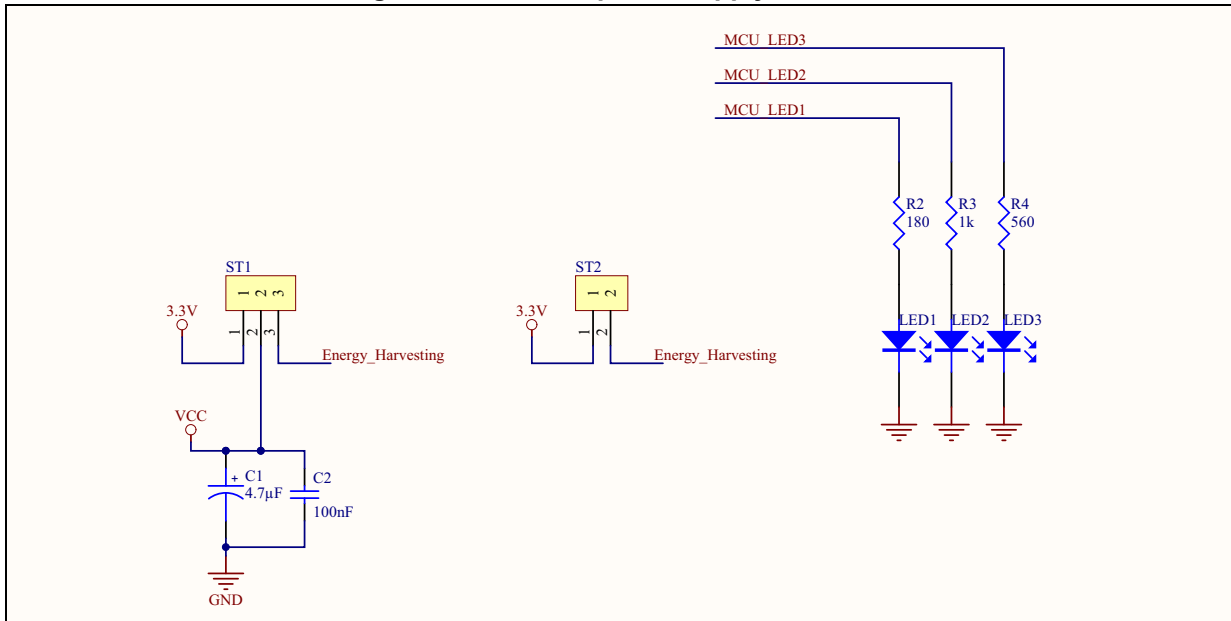

Figure 6. LEDs and power supply selection



## 5 Bill of materials (BOM)

Table 4. BOM

Qty	Description	Ref	Package	Manufacturer	Part no.	Distributor	Order code
1	I2C/NFC EEPROM M24LR04E RMN6T/2	U1	SO8N	STMicroelectronics	M24LR04E RMN6T/2	-	-
1	LED, 1206, GREEN Green LED	LED1	LED-1206	DIALIGHT	5988270107F	Farnell	1466000
1	LED, 1206, BLUE Blue LED	LED2			5988291107F		2113953
1	LED, 1206, YELLOW Yellow LED	LED3			5988240107F		1465998
1	Capacitor 293D TANTAL SMD POL CAP 4.7uF 16V 10% Boitier A 4.7µF	C1	293D-A	-	-	-	-
2	Capacitor <sup>(1)</sup> MLCC 0603 NP0 50V 2% NC	C5, C6	0603	-	-	-	-
1	Capacitor MLCC 0603 NP0 50V 5% 100 nF	C2		-	-	Farnell	1740621
2	Capacitor MLCC 0603 NP0 50V 5% 10 nF	C3, C4		-	-		1833871

Table 4. BOM (continued)

Qty	Description	Ref	Package	Manufacturer	Part no.	Distributor	Order code
2	Resistor CMS 0603 0,1W 5% 0	R1, R8	0603	-	-	-	-
1	Resistor CMS 0603 0,1W 5% 180	R2		-	-	-	-
1	Resistor CMS 0603 0,1W 5% 560	R48		-	-	-	-
2	Resistor CMS 0603 0,1W 5% 1k	R3		-	-	-	-
2	Resistor CMS 0603 0,1W 5% 15k	R5, R6		-	-	-	-
1	Resistor CMS 0603 0,1W 5% 20k	R7		-	-	-	-
1	Connector 2pts <sup>(1)</sup>	ST2	CON_2PTS_P2.54	FCI	77311-401-36LF	Farnell	1097954
1	Connector 3pts	ST1	CON_3PTS_P2.54		77311-401-36LF		1097954
1	Receptacle, 2.54 mm, single row, 10WAY	CN1	1*10P_FEMALE	Samtec	SQ-110-03-L-S		2283783
1	Receptacle, 2.54 mm, single row, 10WAY	CN3	1*6P_FEMALE		SQ-106-03-L-S		2283759
2	Receptacle, 2.54 mm, single row, 10WAY	CN2, CN4	1*8P_FEMALE		SQ-108-03-L-S		2283782

1. Not fitted

## **6 Federal Communications Commission (FCC) and Industry Canada (IC) Compliance Statements**

### **6.1 FCC Compliance Statement**

#### **6.1.1 Part 15.19**

This device complies with Part 15 of the FCC Rules. Operation is subject to the following two conditions: (1) this device may not cause harmful interference, and (2) this device must accept any interference received, including interference that may cause undesired operation.

#### **6.1.2 Part 15.105**

This equipment has been tested and found to comply with the limits for a Class B digital device, pursuant to part 15 of the FCC Rules. These limits are designed to provide reasonable protection against harmful interference in a residential installation. This equipment generates uses and can radiate radio frequency energy and, if not installed and used in accordance with the instructions, may cause harmful interference to radio communications. However, there is no guarantee that interference will not occur in a particular installation. If this equipment does cause harmful interference to radio or television reception, which can be determined by turning the equipment off and on, the user is encouraged to try to correct the interference's by one or more of the following measures:

- Reorient or relocate the receiving antenna.
- Increase the separation between the equipment and the receiver.
- Connect the equipment into an outlet on a circuit different from that to which the receiver is connected.
- Consult the dealer or an experienced radio/TV technician for help.

#### **6.1.3 Part 15.21**

Any changes or modifications to this equipment not expressly approved by STMicroelectronics may cause harmful interference and void the user's authority to operate this equipment.

### **6.2 Formal notices required by the Industry Canada**

#### **6.2.1 Compliance Statement**

This device complies with Industry Canada licence-exempt RSS standard(s). Operation is subject to the following two conditions: (1) this device may not cause interference, and (2) this device must accept any interference, including interference that may cause undesired operation.

#### **6.2.2 Déclaration de conformité**

Le présent appareil est conforme aux CNR d'Industrie Canada applicables aux appareils radio exempts de licence. L'exploitation est autorisée aux deux conditions suivantes: (1)

l'appareil ne doit pas produire de brouillage, et (2) l'utilisateur de l'appareil doit accepter tout brouillage radioélectrique subi, même si le brouillage est susceptible d'en compromettre le fonctionnement.

## 7 Revision history

Table 5. Document revision history

Date	Revision	Changes
24-Jul-2014	1	Initial release.
22-Jan-2016	2	Updated document title and <i>Introduction</i> . Removed former sections <i>Section 1: Description</i> , <i>Section 2: Features</i> and <i>Section 3: Hardware and layout description</i> . Added Sections <i>1: Getting started</i> , <i>2: Hardware description</i> , <i>3: Component description</i> , <i>4: Block diagram and hardware schematics</i> , <i>5: Bill of materials (BOM)</i> and <i>6: Federal Communications Commission (FCC) and Industry Canada (IC) Compliance Statements</i> , and their subsections.



**IMPORTANT NOTICE – PLEASE READ CAREFULLY**

STMicroelectronics NV and its subsidiaries ("ST") reserve the right to make changes, corrections, enhancements, modifications, and improvements to ST products and/or to this document at any time without notice. Purchasers should obtain the latest relevant information on ST products before placing orders. ST products are sold pursuant to ST's terms and conditions of sale in place at the time of order acknowledgement.

Purchasers are solely responsible for the choice, selection, and use of ST products and ST assumes no liability for application assistance or the design of Purchasers' products.

No license, express or implied, to any intellectual property right is granted by ST herein.

Resale of ST products with provisions different from the information set forth herein shall void any warranty granted by ST for such product.

ST and the ST logo are trademarks of ST. All other product or service names are the property of their respective owners.

Information in this document supersedes and replaces information previously supplied in any prior versions of this document.

© 2016 STMicroelectronics – All rights reserved