

Type: Female connector straight with 2 rows

Termination: Press-fit, solder

Number of contacts: 10, 20

Pitch: 2.54 mm

Operational current: 1.5 A

Packaging: Tray

Standard: IEC 60603-2



Technical Specifications on page 36

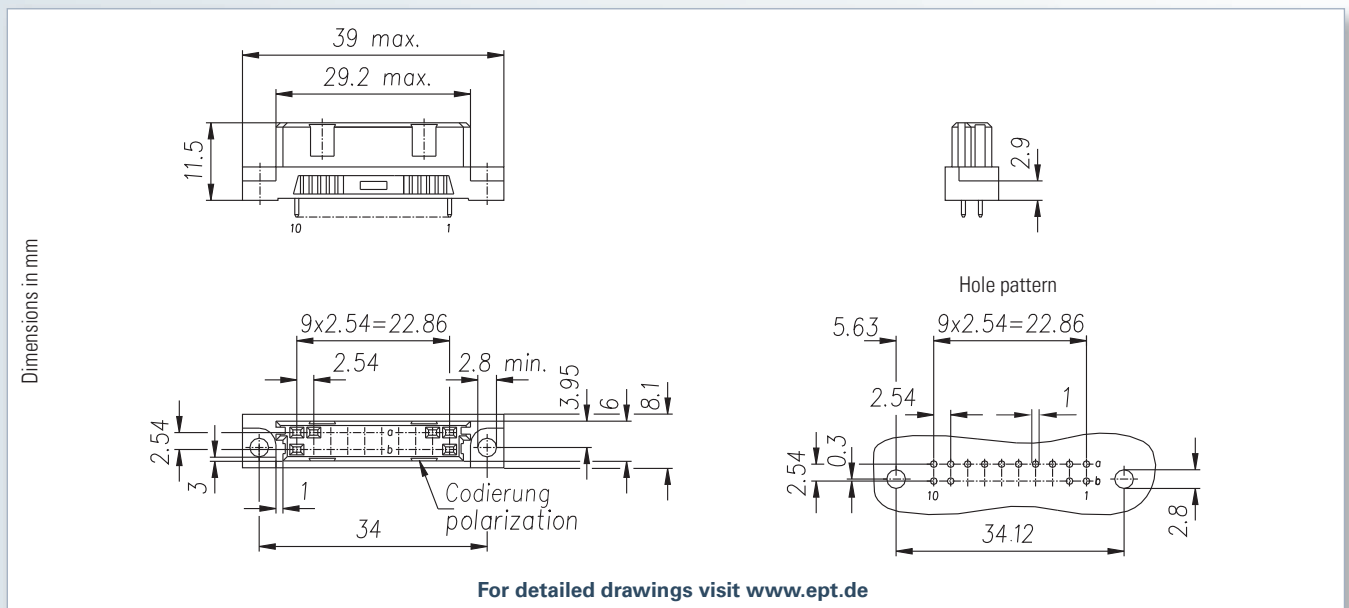

Accessories



- Processing tools p. 300
- Coding p. 132

Mating connector / Application:

 Type B/3 Male connector (p. 48)



Press-fit - Performance level II

| No. of contacts | Contact arrangement | PCB thickness | Termination length L  | | | |
|-----------------|---|---------------|---|--------------|--------------|--------------|
| | | | 3.2 mm | 4.6 mm | 13 mm | 17 mm |
| | | | Part number | | | |
| 20 |  | 1.5 - 2.0 mm | 102-68014-01 | - | 102-78016-01 | 102-78116-01 |
| | | 2.0 - 2.8 mm | - | 102-68014-02 | 102-78016-02 | 102-78116-02 |
| | | > 2.8 mm | - | 102-68014-03 | 102-78016-03 | 102-78116-03 |

On request

- performance level I + III or customized
- special contact length
- alternative contact surface
Sn e. g. for WireWrap
- without flange
- contact arrangement

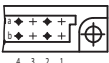
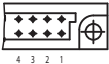

Solder - Performance level II

| No. of contacts | Contact arrangement | Termination length L  | | | |
|-----------------|---|--|-----------|-----------|---|
| | | 2.5 mm | 4 mm | 13 mm | 5.5 mm <small>Manual soldering with solder lug</small> |
| | | Part number | | | |
| 10 |  | 102-80004 | 102-80005 | 102-80006 | 102-80025 |
| 20 |  | 102-80064 | 102-80065 | 102-80066 | 102-80075 |

On request

- performance level I + III or customized
- special contact length
- also in THTR
- Board-Lock p. 131
- contact arrangement