

Dual Operator Continuous Monitor with Satellites Operation, Installation and Maintenance



Made in the United States of America



Figure 1. Vermason VER-28681 Dual Operator Continuous Monitor with Satellites

Description

Leading companies use continuous monitors as a cost effective component in satisfying the clause 5.2.3 Compliance Verification Plan requirements of EN61340-5-1 Edition 1.0 2007-08. The Vermason Dual Operator Continuous Monitor with Satellites continuously monitors the grounding integrity of two operators, and two ESD working surfaces' path to ground. The monitor will provide instantaneous notification of static control equipment failures, and eliminates the need of costly and difficult to supervise wrist strap logging record keeping. This unit is highly cost effective as it is designed to monitor any conventional single-wire wrist strap and ground cord system.

Per ESD Handbook TR 20.20 paragraph 5.3.2.4.4 Test Frequency, "Because wrist straps have a finite life, it is important to develop a test frequency that will guarantee integrity of the system. Typical test programmes recommend that wrist straps that are used daily should be tested daily. However, if the products that are being produced are of such value that knowledge of a continuous, reliable ground is needed, then continuous monitoring should be considered or even required."

The Dual Operator Continuous Monitor with Satellites is available in the following models:

Item	Power Adapter Input	Snap Stud Size
VER-28681	220VAC	4mm
VER-29210	220VAC	10mm

The Dual Operator Continuous Monitor with Satellites is a single-wire impedance continuous monitor designed to monitor body types from a 5th percentile female to a 95th percentile male. This range covers a 5 foot tall 90 pound person to a 6 foot 5 inch 250 pound person in any production environment.* The monitor is powered by a 220 VAC, 60/50 Hz, plug-in transformer which also provides connection to ground.

No user adjustment required: The Continuous Monitor is drift-free and designed to be insensitive to the effects of squeezing or stretching the coil cord. It requires no user adjustment.

The Dual Operator Workstation Continuous Monitor is a real time instrument that ensures that critical ESD control components in a sensitive area are effectively grounded. It independently monitors the operator and the surface. The instant an operators wrist strap or cord fails, the monitor will issue audible and visual alarms alerting the user of the problem. In the same manner, the unit also confirms that a path to ground of less than 10 megohms (1×10^7 ohms) exists from the ESD protective worksurface(s).

All Vermason single-wire monitors with wave distortion technology include the Park Snap feature. Use the Park Snap to store the operator's wrist cord and enable standby mode while the operator is away from the workstation. Before disconnecting the coil cord from the wristband, the operator touches the Park Snap to disable the audio alarm for 6 seconds. Within the 6 second period, the operator can disconnect their wrist cord from their wristband and attach it to the Park Snap before the audible alarm sounds.

ADVANTAGES OF CONTINUOUS MONITORING OVER PERIODIC TESTING

Many customers are eliminating periodic touch testing of wrist straps and are using continuous monitoring to better ensure that their products were manufactured in an ESD protected environment. Full time continuous monitoring is superior to periodic or pulsed testing, and can save a significant amount of money in testing costs and rejected product. Periodic testing detects wrist strap failures after ESD susceptible products have been manufactured. The costs of dealing with the resulting catastrophic failures or latent defects can be considerable. Dual Operator Workstation Continuous Monitors eliminate the need for users to test wrist straps and log the results; by their function, these monitors satisfy the ISO and ANSI/ESD S20.20 test logging.

"A properly grounded wrist strap will keep a person's body voltage to approximately + 10 V. The main advantage to a constant [or continuous] monitor is the immediate indication that the employee receives if the wrist strap falls open. With an unmonitored system, the employee will not be aware of a wrist strap failure until the start of the next shift. This has reliability benefits for an ESD program as it might help reduce or eliminate ESD damage. There are also other process benefits from using constant monitors such as the elimination of the need to maintain daily test logs and a reduction in the time for employees to make the daily test. For units that also monitor the connection of a worksurface to protective earth, it is also possible to reduce or eliminate the checking of the worksurface as part of the periodic audit of the process. Constant monitors might be implemented by an organisation due to high reliability requirements imposed by customers." [CLC/TR 61340-5-2:2008 User guide Annex B.1.3 Constant monitors]

WAVE DISTORTION DETECTION TECHNOLOGY PROVIDES TRUE 100% CONTINUOUS MONITORING

From the technical alternatives available, Vermason designs and manufactures many of its Continuous Monitor product offerings using wave distortion technology . Wave distortion

circuitry monitors current/voltage phase shifts and provides true 100% continuous monitoring. Electrical current will lead voltage at various points due to the combinations of resistance and capacitive reactance. By monitoring these “distortions” or phase shifts, the wave distortion Workstation Continuous Monitor will reliably determine if the circuit is complete. Wave distortion technology can be referred to as “vector impedance monitoring”. This description is valid as the wave distortion technology measures the impedance at the monitored banana jack and looks for changes in either the capacitance or resistance of the circuit which includes the wrist strap and its wearer. It uses filtering and time domain sampling to filter out false signals caused by voltage offsets, 60 Hz fields and other electro-magnetic and electrostatic interference.

In normal factory environments, and with persons whose capacitance with respect to ground is within design limits (5 feet tall 90 pound person to 6 foot 5 inch 250 pound person), the Dual Operator Workstation Continuous Monitor cannot be “fooled”. It will provide a reliable alarm only when the wrist strap or worksurface becomes dysfunctional or unsafe according to accepted industry standards. The Dual Operator Workstation Continuous Monitor is drift-free and designed to be insensitive to the effects of squeezing or stretching the coil cord.

ADVANTAGES OF WAVE DISTORTION AND SINGLE-WIRE TECHNOLOGY

The Vermason Dual Operator Workstation Continuous Monitor allows the use of any standard, single-wire wrist strap and coil cord. The monitor/wrist strap/cord system life-cycle costs are by far lower than alternative systems which require more expensive & less durable dual-wire cords and special wrist straps. Dual-wire cords are expensive and are the weak link of the system. They are the most likely component to need replacement. Over a five year period this can make a dual-wire system three times as expensive as a system using single-wire wrist straps and cords.

The dictionary defines constant as uniform and unchanging, and continuous as uninterrupted. Although Vermason dual-wire resistance monitors use a continuous current, some dual-wire resistance monitors use a pulsed test current and do not really provide continuous monitoring. For example, during each 2.2 second pulse cycle of a leading “constant” resistive monitor, electrical current is pulsed for only 0.2 seconds followed by an unmonitored interval of 2 seconds. This leaves the user/wrist strap unmonitored for over 90% of each cycle. Damaging ESD events can easily occur in the portion of the time in between the pulses. The off period of 2 seconds equals 2 billion nanoseconds, and “it takes only about 25 volts applied for 100 nanoseconds to blow most memories or microprocessor.”* The dual-wire system does not meet all industry ESD S6.1 specifications, as the cords do not meet the EOS/ESD Association guidelines for the 5 to 25N “breakaway force” requirement for ensuring a reliable path-to-ground and preventing accidental disconnects.

By using the reliable wave distortion technology to determine if the circuit is complete, there are no false alarms. There is no need to adjust or tune the monitor to a specific user or

*1981 article by Donald E. Frank - Electrical Overstress Electronic Discharge Symposium Proceedings

installation. The miniscule amount of electrical current (less than 1 volt coil cord signal) required to generate the waveform has never caused reported skin irritation and is extremely safe for use in voltage sensitive applications such as disk drive manufacturing.

Packaging

- 1 Dual Operator Continuous Monitor
- 2 Satellite Remotes (VER-28681 contains 4mm snap studs, VER-29210 contains 10mm snap studs)
- 1 Power Adapter
- 2 Mat Monitor Cords (Black), 1.8m
- 2 Mat Ground Cords (Green and Yellow), 1.8m
- 2 Satellite Remote Cables, 2.1m
- 4 Push and Clinch Snaps
- 4 Countersink Washers
- 6 Screws
- 1 Certificate of Calibration

Installation

Remove the monitor and satellites from its packaging. Inspect for any shipping damage. Confirm that the worksurface is 1×10^7 ohms or less and has a conductive layer such as Dual Layer Rubber, Dissipative 3-Layer Vinyl, or Micastat[®] Dissipative Laminate with conductive buried layers.

The control unit for Dual Operator Continuous Monitor is normally installed under the bench top toward the front edge of a workstation where the LEDs are easily visible. Use the enclosure’s flanges to mount the monitor.



Figure 2. Mounting the monitor

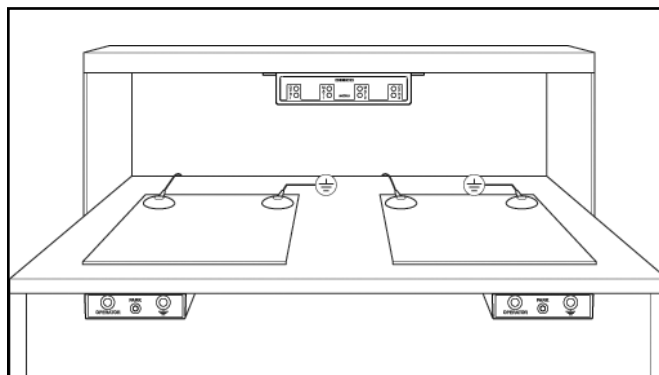

Figure 3. Typical setup of the Dual Operator Continuous Monitor and Satellites

SATELLITE REMOTES

The Satellite Remotes can be installed up to 2.1 meters away from the monitor control unit. Two operators plus two worksurfaces can be monitored at separate adjacent workstations. The worksurface mat circuit may be bypassed by a switch located at the rear of the satellite.



Also shown on each satellite remote is an unmonitored ground connection jack where a supervisor, guest, or equipment can be grounded.

The following procedure will outline how to correctly install the Dual Operator Continuous Monitor and its satellites to properly monitor an ESD protected workstation.

1. Connect the Satellite Remotes to the Control Unit using the included cables.

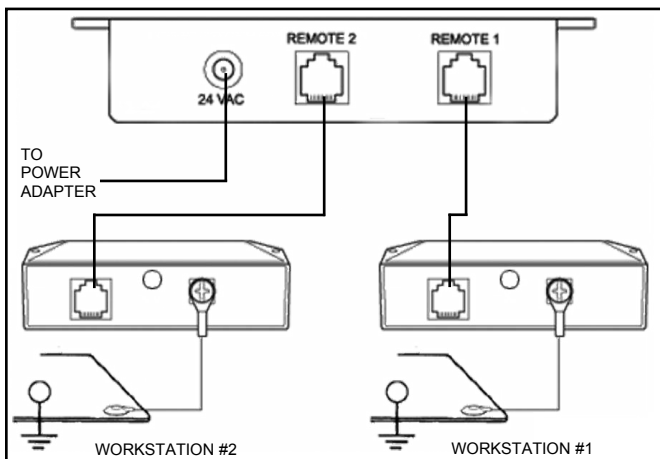

Figure 4. Wiring the Dual Operator Continuous Monitor and Satellites

2. Mat monitoring may be bypassed by using the switch located inside the hole located at the rear of the satellite remote.
3. Install Screws and Washers or Push and Clinch snaps 30 to 183 cm apart from each other on the worksurface mat. Make sure that they pierce and clinch the bottom side of the mat.
4. Ground the worksurfaces by using the included mat ground cords. Snap one end to the push and clinch snap and connect the other end to common point ground.
5. Connect the mat ground cord to the remaining push and clinch snap. Connect the other end of the cord to the back of the satellite remote.

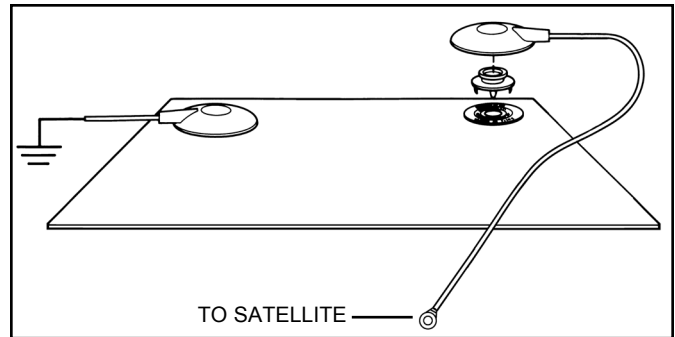

Figure 5. Installing the Mat and Monitor Ground Cords to the worksurface

6. A convenient 3-wire 220 VAC outlet should be located and tested for proper wiring and grounding. We recommend using the Vermason AC Outlet Analyser to perform these tests.
7. Plug the power adapter into the outlet and connect the plug into the rear of the control unit. The green worksurface LEDs should illuminate. If the red worksurface LED(s) illuminates and alarms, inspect the snap fastener and ground cords for proper connection. The operator LEDs will illuminate red when an operator is not connected. The Dual Operator Continuous Monitor is now ready for use.

NOTE: Always keep a 10mm wrist cord connected between the operator and parking snaps on the satellite remotes for the VER-29210 monitor when not in use by an operator. The monitor will alarm when the remotes' operator snaps are not in use or parked with a wrist cord.

Installation on Micastat® Laminate

Materials Needed:

- 2 Flush Mount Ground Laminate Inserts
- 1 Installation Tool for Flush Mount Insert

1. Install the Flush Mount Inserts first. It is recommended to install one in the right back corner and the other in the left back corner of the Micastat® laminated bench top.
2. Once both inserts are installed, cut the ground cord supplied with the monitor into two pieces; make sure that the tinned end is long enough to connect from the worksurface terminal on the Satellite Remote to one of the flush mount terminals located under the bench.
3. The remaining wire can then be used to connect the other flush mount terminal to ground using the supplied ring terminal. The shrouded molded end can then be cut off.

When complete, one flush mount terminal will connect the Micastat® laminate to ground while the other will connect it to a satellite remote. The satellite remote then monitors the ground connection between the two inserts, and since Micastat® is the only ESD laminate made with a physical uniform ground layer, it will monitor the entire Micastat® surface ground. The wires will stay under the bench, maximising the usable space on the bench top.

Operation

When the satellite remote unit is installed and connected to a grounded ESD protective worksurface, the monitor's green worksurfaces LED's and red operator LED's should be illuminated. The monitor takes 6 seconds to activate its alarm circuitry when it is first plugged in.

To use the monitor:

1. Plug a wrist strap cord, into the jack labeled OPERATOR on the satellite remotes. This automatically activates the selected operator channel. The red operator LED should illuminate and the buzzer should sound.
2. Remove the charges from your body by making contact with a properly grounded ESD worksurface. Snap the cord to the wristband, which should fit snugly on your wrist. This should silence the alarm and cause the LEDs to switch from red to green. If this does not happen, check the wrist cord for continuity or damage. Examine your wristband and ensure that it has a secure fit. If you have dry skin, use ESD hand lotion.

When leaving the area, the operator may take the wrist cord along or unsnap the cord from wristband and attach it to the parking snap located on the satellite remote. This will de-activate the alarm and allow the operator to leave the workstation. If the cord is plugged into the OPERATOR jack, the monitor will alarm continuously until the cord is either parked or unplugged.

WORKSURFACE CHANNEL

The Dual Operator Continuous Monitor's worksurface monitoring circuitry is sufficiently sensitive to detect extremely low current, allowing it to be used with mats having a resistance of up to 1×10^7 ohms (10 megohms). If the user desires not to monitor the worksurface, the circuit can be bypassed with the switch located at the rear of the satellite.

When the monitor is connected to a static dissipative worksurface, the amount of current that flows is a function of the total resistance between the monitor and the worksurface to ground. When the resistance of the worksurface is below a present threshold, the monitor will indicate good. Conversely, if the resistance level is high when compared to the monitor's reference, the unit will alarm. This is an integrating resistance measuring circuit. Therefore, it is relatively insensitive to externally induced electromagnetic fields. The resistance threshold is factory set to 10 megohms (1×10^7 ohms). Custom worksurface range is available upon request. Contact customer service for more details.

Note: Per ESD S6.1, Grounding paragraph 4.1.1 "Every element to be grounded at an ESD protected station shall be connected to the same common point ground." The ESD control plan should include a tailoring** statement that continuous monitors are used and that consistent with manufacturer's design grounding is via AC adapter cord to equipment ground.

Maintenance and Calibration

The Dual Operator Workstation Continuous Monitor is solid state and designed to be maintenance free. It is calibrated to NIST traceable standards. There are no user adjustments that can be made. Because of the impedance sensing nature of the test circuit, special equipment is required for calibration. We recommend using the VER-28682 Continuous Monitor Calibration Unit whenever calibration is performed annually or any of the satellite remotes are replaced. The Calibration Unit is a most important product which allows the customer to perform NIST traceable calibration on continuous monitors and can be used to perform compliance verification required by EN61340-5-1. The VER-28682 is designed to be used on the shop floor at the workstation, virtually eliminating downtime, verifying that the continuous monitor is operating within tolerances.

Specifications

Test range of monitored circuit	500K - 10M ohms†
Supervisor Jack	
Resistance to Ground	47k ohms typical
Worksurface Limit*	Set to 10 Megohms (1×10^7 ohms)
Operating Voltage	220-240 VAC, 50-60 Hz
Wrist strap open circuit voltage	1.2 volts peak to peak @ 1-2 MicroAmps
Mat test open circuit voltage	5 to 7.5 volts
Response time to alarm	< 50 mS
Operating Temperature	0 - 40°C
Long Term Drift	<0.5% per Decade (1st Decade is 1 hr)

NOTE: Worksurface must have a conductive layer such as Dual Layer Rubber or Dissipative 3-Layer Vinyl or Micastat® Dissipative Laminate with conductive buried layers. Vermason Continuous Monitors are not recommended for use with homogeneous matting.

† This cannot be verified with standard DC test equipment. The continuous monitor is an impedance sensing device and the limits are determined by the magnitude and angle of the impedance.

*Contact factory for special limits.

Limited Warranty

Vermason expressly warrants that for a period of one (1) year from the date of purchase, Vermason Continuous Monitors will be free of defects in material (parts) and workmanship (labour). Within the warranty period, a unit will be tested, repaired or replaced at Vermason's option, free of charge. Call Customer Service at 0044 (0) 1462 672005 for a Return Material Authorisation (RMA) and for proper shipping instructions and address. Any unit under warranty should be shipped prepaid to the Vermason factory. You should include a copy of your original packing slip, invoice, or other proof of purchase date. Warranty repairs will take approximately two weeks.

If your unit is out of warranty, Vermason will quote repair charges necessary to bring your unit to factory standards. Call Customer Service at 0044 (0) 1462 672005 for a Return Material Authorisation (RMA) and proper shipping instructions and address.

Warranty Exclusions

THE FOREGOING EXPRESS WARRANTY IS MADE IN LIEU OF ALL OTHER PRODUCT WARRANTIES, EXPRESSED AND IMPLIED, INCLUDING MERCHANTABILITY AND FITNESS FOR A PARTICULAR PURPOSE WHICH ARE SPECIFICALLY DISCLAIMED. The express warranty will not apply to defects or damage due to accidents, neglect, misuse, alterations, operator error, or failure to properly maintain, clean or repair products.

Limit of liability

In no event will Vermason or any seller be responsible or liable for any injury, loss or damage, direct or consequential, arising out of the use of or the inability to use the product. Before using, users shall determine the suitability of the product for their intended use, and users assume all risk and liability whatsoever in connection therewith.