

2.6

Adjustable Frequency Drives

PowerXL DG1 Series Drives

DG1 General Purpose Drive

2



Contents

Description	Page
PowerXL DG1 Series Drives	
Standards and Certifications	V6-T2-49
Catalog Number Selection	V6-T2-49
Product Selection	V6-T2-50
Accessories	V6-T2-53
Replacement Parts	V6-T2-59
Technical Data and Specifications	V6-T2-62
Dimensions	V6-T2-67
PowerXL DG1 Series Enclosed Drives	V6-T2-68

PowerXL DG1 Series Drives

Product Description

The DG1 general purpose drives are part of Eaton’s next generation PowerXL Series of adjustable frequency drives specifically engineered for today’s more demanding commercial and industrial applications. The power unit makes use of the most sophisticated semiconductor technology and a highly modular construction that can be flexibly adapted to meet the customer’s needs.

The control module was designed to include today’s standard communication protocols and I/O while still having the modularity to add additional option cards.

Eaton’s patented Active Energy Control is also a standard feature on DG1 drives, offering customers increased efficiency, safety and reliability.

These drives continue the tradition of robust performance and raise the bar on features and functionality, ensuring the best solution at the right price.

Product Range

230 V to 125 hp, 312 A, 90 kW

480 V to 250 hp, 310 A, 160 kW

575 V to 250 hp, 250 A, 160 kW

Features and Benefits

Hardware

- Brake chopper standard on Frames 1, 2, 3
- Dual overload ratings
 - 110% variable torque (I_L)
 - 150% constant torque (I_H)
- Type 1/IP21 and Type 12/IP54 enclosures available
- Integrated common mode reduction 5% DC link choke with input surge protection
- EMI/RFI filters standard on all drives—meets EMC Category C2
- Real-time clock—supports calendaring and PLC functionality
- Graphic LCD display and keypad—supports simple menu navigation as well as on-screen diagnostics and troubleshooting
- LOCAL/REMOTE operation from keypad and two configurable soft keys
- Conformal coated control and power boards standard

- Control logic can be powered from an external auxiliary control panel—internal drive functions and fieldbus if necessary
- Standard I/O:
 - 8DI, 1DO
 - 2AI, 2AO
 - 2FC, 1FA relays
- Standard communications:
 - EtherNet/IP, Modbus TCP
 - RS-485: Modbus RTU, BACnet MS/TP
- Seamless integration into EtherNet/IP networks via EIP-Assist I/O tag-generation tool
- Two expansion slots—intended to support additional I/O or communication protocols as necessary
- Quick disconnect terminals for I/O connections—supports fast easy installation
- Safe Torque Off (STO) built-in with functional safety SIL1 certification

Software

- Active energy control—minimizes energy losses in your motor, resulting in industry-leading energy efficiency for your application
- Quick Start Wizard upon initial power-up supports fast, easy installation
- Standard applications:
 - Standard
 - Multi-pump and fan Control
 - Multi-PID
 - Multi-purpose
- Copy/paste functionality on drive keypad—allows for fast setup of multiple drives
- Pre-programmed I/O—supports fast, easy installation for most applications
- Dynamic motor regenerative energy management
- Advanced PC Tool with diagnostic capabilities
- Two keypad software keys for easy menu navigation and shortcuts

Standards and Certifications

Product

- IEC/EN 61800-5-1
- IEC/EN 61800-5-2
- UL 508C
- IEC 61508
- EN 62061
- EN ISO 13849-1

EMC

- Immunity: IEC/EN 61800-3
- Category C2

Certification

- UL
- cUL
- CE
- C-Tick
- RoHS
- EAC
- Plenum rated



Catalog Number Selection

Catalog Number Selection is for illustrative purposes only and not to be used to create new catalog numbers.

PowerXL Series—DG1 General Purpose Drive

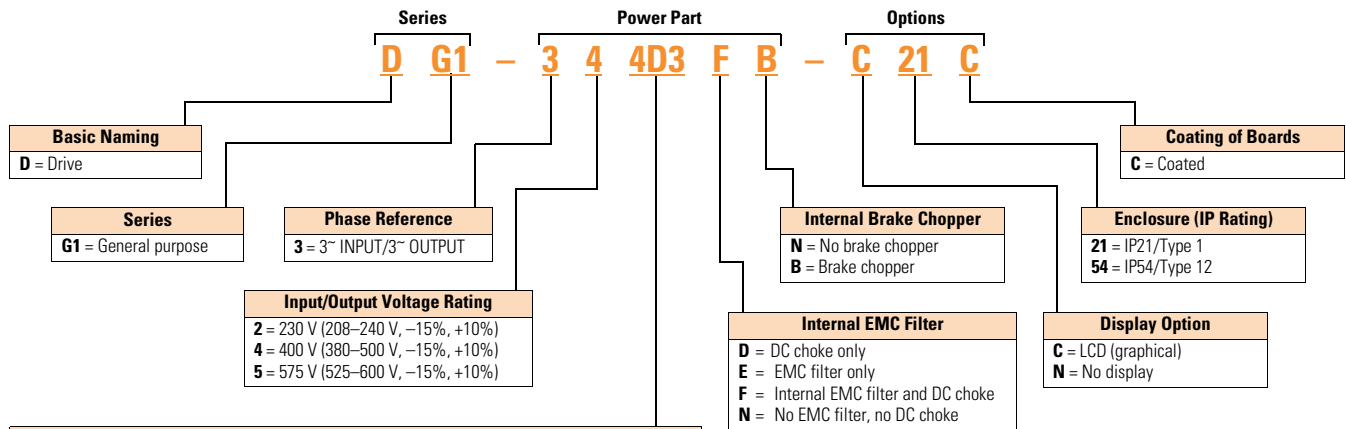

Output Current Rating (CT)		
208–240 V	380–500 V	525–600 V
3D7 = 3.7 A, 0.55 kW, 0.75 hp	2D2 = 2.2 A, 0.75 kW, 1 hp	3D3 = 3.3 A, 1.5 kW, 2 hp
4D8 = 4.8 A, 0.75 kW, 1 hp	3D3 = 3.3 A, 1.1 kW, 1.5 hp	4D5 = 4.5 A, 2.2 kW, 3 hp
6D6 = 6.6 A, 1.1 kW, 1.5 hp	4D3 = 4.3 A, 1.5 kW, 2 hp	7D5 = 7.5 A, 3.7 kW, 5 hp
7D8 = 7.8 A, 1.5 kW, 2 hp	5D6 = 5.6 A, 2.2 kW, 3 hp	010 = 10 A, 5.5 kW, 7.5 hp
011 = 11 A, 2.2 kW, 3 hp	7D6 = 7.6 A, 3 kW, 5 hp	013 = 13.5 A, 7.5 kW, 10 hp
012 = 12.5 A, 3 kW, 5 hp (VT)	9D0 = 9 A, 4 kW, 7.5 hp (VT)	018 = 18 A, 11 kW, 15 hp
017 = 17.5 A, 3.7 kW, 5 hp	012 = 12 A, 5.5 kW, 7.5 hp	022 = 22 A, 15 kW, 20 hp
025 = 25 A, 5.5 kW, 7.5 hp	016 = 16 A, 7.5 kW, 10 hp	027 = 27 A, 18 kW, 25 hp
031 = 31 A, 7.5 kW, 10 hp	023 = 23 A, 11 kW, 15 hp	034 = 34 A, 22 kW, 30 hp
048 = 48 A, 11 kW, 15 hp	031 = 31 A, 15 kW, 20 hp	041 = 41 A, 30 kW, 40 hp
061 = 61 A, 15 kW, 20 hp	038 = 38 A, 18 kW, 25 hp	052 = 52 A, 37 kW, 50 hp
075 = 75 A, 18.5 kW, 25 hp	046 = 46 A, 22 kW, 30 hp	062 = 62 A, 45 kW, 60 hp
088 = 88 A, 22 kW, 30 hp	061 = 61 A, 30 kW, 40 hp	080 = 80 A, 55 kW, 75 hp
114 = 114 A, 30 kW, 40 hp	072 = 72 A, 37 kW, 50 hp	100 = 100 A, 75 kW, 100 hp
143 = 143 A, 37 kW, 50 hp	087 = 87 A, 45 kW, 60 hp	125 = 125 A, 90 kW, 125 hp
170 = 170 A, 45 kW, 60 hp	105 = 105 A, 55 kW, 75 hp	144 = 144 A, 110 kW, 150 hp
211 = 211 A, 55 kW, 75 hp	140 = 140 A, 75 kW, 100 hp	208 = 208 A, 160 kW, 200 hp
248 = 248 A, 75 kW, 100 hp	170 = 170 A, 90 kW, 125 hp	
	205 = 205 A, 110 kW, 150 hp	
	245 = 245 A, 150 kW, 200 hp	

PowerXL Series—DG1 General Purpose Drive Option Boards

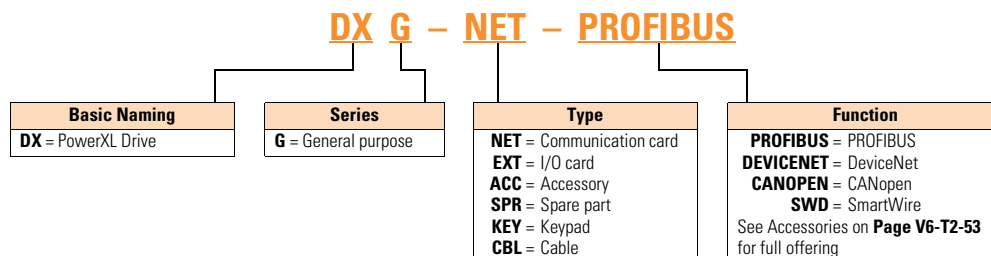

2.6

Adjustable Frequency Drives

PowerXL DG1 Series Drives

Product Selection

DG1 Series Drives—208–240 Volt

2

PowerXL Series—DG1 Type 1/IP21



Frame Size	Constant Torque (CT) / High Overload (I_H)			Variable Torque (VT) / Low Overload (I_L)			Catalog Number
	230 V, 50 Hz kW Rating	230 V, 60 Hz hp	Current A	230 V, 50 Hz kW Rating	230 V, 60 Hz hp	Current A	
FR1	0.55	0.75	3.7	0.75	1	4.8	DG1-323D7FB-C21C
	0.75	1	4.8	1.1	1.5	6.6	DG1-324D8FB-C21C
	1.1	1.5	6.6	1.5	2	7.8	DG1-326D6FB-C21C
	1.5	2	7.8	2.2	3	11	DG1-327D8FB-C21C
	2.2	3	11	3	—	12.5	DG1-32011FB-C21C
FR2	3	—	12.5	3.7	5	17.5	DG1-32012FB-C21C
	3.7	5	17.5	5.5	7.5	25	DG1-32017FB-C21C
	5.5	7.5	25	7.5	10	31	DG1-32025FB-C21C
FR3	7.5	10	31	11	15	48	DG1-32031FB-C21C
	11	15	48	15	20	61	DG1-32048FB-C21C
FR4	15	20	61	18.5	25	75	DG1-32061FN-C21C
	18.5	25	75	22	30	88	DG1-32075FN-C21C
	22	30	88	30	40	114	DG1-32088FN-C21C
FR5	30	40	114	37	50	143	DG1-32114FN-C21C
	37	50	143	45	60	170	DG1-32143FN-C21C
	45	60	170	55	75	211	DG1-32170FN-C21C
FR6 ①	55	75	211	75	100	261	DG1-32211FN-C21C
	75	100	248	90	125	312	DG1-32248FN-C21C

PowerXL Series—DG1 Type 12/IP54



Frame Size	Constant Torque (CT) / High Overload (I_H)			Variable Torque (VT) / Low Overload (I_L)			Catalog Number
	230 V, 50 Hz kW Rating	230 V, 60 Hz hp	Current A	230 V, 50 Hz kW Rating	230 V, 60 Hz hp	Current A	
FR1	0.55	0.75	3.7	0.75	1	4.8	DG1-323D7FB-C54C
	0.75	1	4.8	1.1	1.5	6.6	DG1-324D8FB-C54C
	1.1	1.5	6.6	1.5	2	7.8	DG1-326D6FB-C54C
	1.5	2	7.8	2.2	3	11	DG1-327D8FB-C54C
	2.2	3	11	3	—	12.5	DG1-32011FB-C54C
FR2	3	—	12.5	3.7	5	17.5	DG1-32012FB-C54C
	3.7	5	17.5	5.5	7.5	25	DG1-32017FB-C54C
	5.5	7.5	25	7.5	10	31	DG1-32025FB-C54C
FR3	7.5	10	31	11	15	48	DG1-32031FB-C54C
	11	15	48	15	20	61	DG1-32048FB-C54C
FR4	15	20	61	18.5	25	75	DG1-32061FN-C54C
	18.5	25	75	22	30	88	DG1-32075FN-C54C
	22	30	88	30	40	114	DG1-32088FN-C54C
FR5	30	40	114	37	50	143	DG1-32114FN-C54C
	37	50	143	45	60	170	DG1-32143FN-C54C
	45	60	170	55	75	211	DG1-32170FN-C54C
FR6 ①	55	75	211	75	100	261	DG1-32211FN-C54C
	75	100	248	90	125	312	DG1-32248FN-C54C

Note

① FR6 available in 2016.

DG1 Series Drives—380–500 Volt

PowerXL Series—DG1 Type 1/IP21



Frame Size	Constant Torque (CT) / High Overload (I_H)			Variable Torque (VT) / Low Overload (I_L)			Catalog Number
	400 V, 50 Hz kW Rating	460 V, 60 Hz hp	Current A	400 V, 50 Hz kW Rating	460 V, 60 Hz hp	Current A	
FR1	0.75	1	2.2	1.1	1.5	3.3	DG1-342D2FB-C21C
	1.1	1.5	3.3	1.5	2	4.3	DG1-343D3FB-C21C
	1.5	2	4.3	2.2	3	5.6	DG1-344D3FB-C21C
	2.2	3	5.6	3	5	7.6	DG1-345D6FB-C21C
	3	5	7.6	4	—	9	DG1-347D6FB-C21C
	4	—	9	5.5	7.5	12	DG1-349D0FB-C21C
FR2	5.5	7.5	12	7.5	10	16	DG1-34012FB-C21C
	7.5	10	16	11	15	23	DG1-34016FB-C21C
	11	15	23	15	20	31	DG1-34023FB-C21C
FR3	15	20	31	18.5	25	38	DG1-34031FB-C21C
	18.5	25	38	22	30	46	DG1-34038FB-C21C
	22	30	46	30	40	61	DG1-34046FB-C21C
FR4	30	40	61	37	50	72	DG1-34061FN-C21C
	37	50	72	45	60	87	DG1-34072FN-C21C
	45	60	87	55	75	105	DG1-34087FN-C21C
FR5	55	75	105	75	100	140	DG1-34105FN-C21C
	75	100	140	90	125	170	DG1-34140FN-C21C
	90	125	170	110	150	205	DG1-34170FN-C21C
FR6 ①	110	150	205	132	200	261	DG1-34205FN-C21C
	150	200	245	160	250	310	DG1-34245FN-C21C

PowerXL Series—DG1 Type 12/IP54



Frame Size	Constant Torque (CT) / High Overload (I_H)			Variable Torque (VT) / Low Overload (I_L)			Catalog Number
	400 V, 50 Hz kW Rating	460 V, 60 Hz hp	Current A	400 V, 50 Hz kW Rating	460 V, 60 Hz hp	Current A	
FR1	0.75	1	2.2	1.1	1.5	3.3	DG1-342D2FB-C54C
	1.1	1.5	3.3	1.5	2	4.3	DG1-343D3FB-C54C
	1.5	2	4.3	2.2	3	5.6	DG1-344D3FB-C54C
	2.2	3	5.6	3	5	7.6	DG1-345D6FB-C54C
	3	5	7.6	4	—	9	DG1-347D6FB-C54C
	4	—	9	5.5	7.5	12	DG1-349D0FB-C54C
FR2	5.5	7.5	12	7.5	10	16	DG1-34012FB-C54C
	7.5	10	16	11	15	23	DG1-34016FB-C54C
	11	15	23	15	20	31	DG1-34023FB-C54C
FR3	15	20	31	18.5	25	38	DG1-34031FB-C54C
	18.5	25	38	22	30	46	DG1-34038FB-C54C
	22	30	46	30	40	61	DG1-34046FB-C54C
FR4	30	40	61	37	50	72	DG1-34061FN-C54C
	37	50	72	45	60	87	DG1-34072FN-C54C
	45	60	87	55	75	105	DG1-34087FN-C54C
FR5	55	75	105	75	100	140	DG1-34105FN-C54C
	75	100	140	90	125	170	DG1-34140FN-C54C
	90	125	170	110	150	205	DG1-34170FN-C54C
FR6 ①	110	150	205	132	200	261	DG1-34205FN-C54C
	150	200	245	160	250	310	DG1-34245FN-C54C

Note

① FR6 available in 2016.

2.6

Adjustable Frequency Drives

PowerXL DG1 Series Drives

DG1 Series Drives—575 Volt^①

2

PowerXL Series—DG1 Type 1/IP21



Frame Size	Constant Torque (CT) / High Overload (I _H)			Variable Torque (VT) / Low Overload (I _L)			Catalog Number
	575 V, 60 Hz kW Rating	575 V, 60 Hz hp	Current A	575 V, 60 Hz kW Rating	575 V, 60 Hz hp	Current A	
FR1	1.5	2	3.3	2.2	3	4.5	DG1-353D3FB-C21C
	2.2	3	4.5	3.7	5	7.5	DG1-354D5FB-C21C
	3.7	5	7.5	5.5	7.5	10	DG1-357D5FB-C21C
FR2	5.5	7.5	10	7.5	10	13.5	DG1-35010FB-C21C
	7.5	10	13.5	11	15	18	DG1-35013FB-C21C
	11	15	18	15	20	22	DG1-35018FB-C21C
FR3	15	20	22	18.5	25	27	DG1-35022FB-C21C
	18.5	25	27	22	30	34	DG1-35027FB-C21C
	22	30	34	30	40	41	DG1-35034FB-C21C
FR4	30	40	41	37	50	52	DG1-35041FN-C21C
	37	50	52	45	60	62	DG1-35052FN-C21C
	45	60	62	55	75	80	DG1-35062FN-C21C
FR5	55	75	80	75	100	100	DG1-35080FN-C21C
	75	100	100	90	125	125	DG1-35100FN-C21C
	90	125	125	110	150	144	DG1-35125FN-C21C
FR6 ^②	110	150	144	150	200	208	DG1-35144FN-C21C
	150	200	208	187	250	250	DG1-35208FN-C21C

PowerXL Series—DG1 Type 12/IP54



Frame Size	Constant Torque (CT) / High Overload (I _H)			Variable Torque (VT) / Low Overload (I _L)			Catalog Number
	575 V, 60 Hz kW Rating	575 V, 60 Hz hp	Current A	575 V, 60 Hz kW Rating	575 V, 60 Hz hp	Current A	
FR1	1.5	2	3.3	2.2	3	4.5	DG1-353D3FB-C54C
	2.2	3	4.5	3.7	5	7.5	DG1-354D5FB-C54C
	3.7	5	7.5	5.5	7.5	10	DG1-357D5FB-C54C
FR2	5.5	7.5	10	7.5	10	13.5	DG1-35010FB-C54C
	7.5	10	13.5	11	15	18	DG1-35013FB-C54C
	11	15	18	15	20	22	DG1-35018FB-C54C
FR3	15	20	22	18.5	25	27	DG1-35022FB-C54C
	18.5	25	27	22	30	34	DG1-35027FB-C54C
	22	30	34	30	40	41	DG1-35034FB-C54C
FR4	30	40	41	37	50	52	DG1-35041FN-C54C
	37	50	52	45	60	62	DG1-35052FN-C54C
	45	60	62	55	75	80	DG1-35062FN-C54C
FR5	55	75	80	75	100	100	DG1-35080FN-C54C
	75	100	100	90	125	125	DG1-35100FN-C54C
	90	125	125	110	150	144	DG1-35125FN-C54C
FR6 ^②	110	150	144	150	200	208	DG1-35144FN-C54C
	150	200	208	187	250	250	DG1-35208FN-C54C

Notes

- ① 575 V available May 2015.
- ② FR6 available in 2016.

Accessories

The PowerXL Series—DG1 drives can accommodate a wide selection of expander and adapter option boards to customize the drive for your application needs. The drive's control unit is designed to accept a total of two additional option boards.

The PowerXL Series—DG1 drives come with a factory-installed standard board configuration including the following:

- Standard I/O:
 - 8DI, 1DO
 - 2AI, 2AO
 - 2FC, 1FA relays
- Standard communications:
 - EtherNet/IP, Modbus TCP
 - RS-485: Modbus RTU, BACnet MS/TP

PowerXL Series—DG1 I/O Card Kits

Description	Catalog Number
3 x DI, 3 x DO, 1 x thermistor, 24 Vdc/EXT option card	DXG-EXT-3DI3DO1T
1 x AI, 2 x AO (isolated to control board) option card	DXG-EXT-1AI2AO
3 x relay dry contact (2NO + 1NO/NC) option card	DXG-EXT-3R0
3 x PT100 RTD thermistor input option card	DXG-EXT-THER1
6 x DI 240 Vac input option card	DXG-EXT-6DI

PowerXL Series—DG1 Communication Card Kits

Description	Catalog Number
PROFIBUS-DP communication card	DXG-NET-PROFIBUS
CANopen communication card	DXG-NET-CANOPEN
DeviceNet communication card	DXG-NET-DEVICENET
PROFIBUS DB9 to 5-pin adapter card	DXG-MNT-PROFIBUS
SmartWire communication card and module	DXG-NET-SWD

PowerXL Series—DG1 Keypad Kits

Description	Catalog Number
Standard keypad	DXG-KEY-LCD
Remote keypad kit (IP 54 rated keypad holder and 3 m cable)	DXG-KEY-RMTKIT
1 m remote keypad cable	DXG-CBL-1M0
3 m remote keypad cable	DXG-CBL-3M0
Remote keypad mounting holder only	DXG-KEY-HOLDER
Type 12/IP54 keypad hole plug (maintain rating without keypad)	DXG-KEY-N12PLUG

PowerXL Series—DG1 Conversion and Flange Kits

The Type 12/IP54 option kit is used to convert a Type 1/IP21 to a Type 12/IP54 drive. The kit includes cover, fan and grommets.

Type 12/IP54 Conversion Kits ^①

Description	Catalog Number
Frame 1 230 V Type 12/IP54 kit	DXG-ACC-2FR1N12KIT
Frame 1 480 V Type 12/IP54 kit	DXG-ACC-4FR1N12KIT
Frame 2 Type 12/IP54 kit	DXG-ACC-FR2N12KIT

The flange kit is used when the power section heat sink is mounted through the back panel of an enclosure. The kit includes hardware, top flange plate, bottom flange plate and two side flange plates.

Flange Kits

Description	Catalog Number
Frame 1 flange kit Type 12/IP54	DXG-ACC-FR1N12FK
Frame 2 flange kit Type 12/IP54	DXG-ACC-FR2N12FK
Frame 3 flange kit Type 12/IP54	DXG-ACC-FR3N12FK
Frame 4 flange kit Type 12/IP54	DXG-ACC-FR4N12FK
Frame 5 flange kit Type 12/IP54	DXG-ACC-FR5N12FK

PowerXL Series—DG1 Demo Units

Demo Units

Description	Catalog Number
DG1 control module demo stand	DG1-DEMO1
DG1 full drive demo case	DG1-DEMO2

Note

^① For Frame 3 and above, consult factory.

2.6

Adjustable Frequency Drives

PowerXL DG1 Series Drives

Power Xpert inControl Software

The PowerXL Series PC Tool is designed for programming, controlling and monitoring of the DG1 drives. Features include loading parameters that can be saved to a file or printed, setting references, starting and stopping the motor, monitoring signals in graphical or text form, and real-time display.

2

PowerXpert inControl Software

Description	Catalog Number
Software kit (software, cable, manual)	DXG-ACC-SOFTWARE
Software cable (USB to keypad [RJ45])	DXG-CBL-PCCABLE
Real-time clock battery (approximately 10,000 hours life)	DXG-ACC-RTBATT

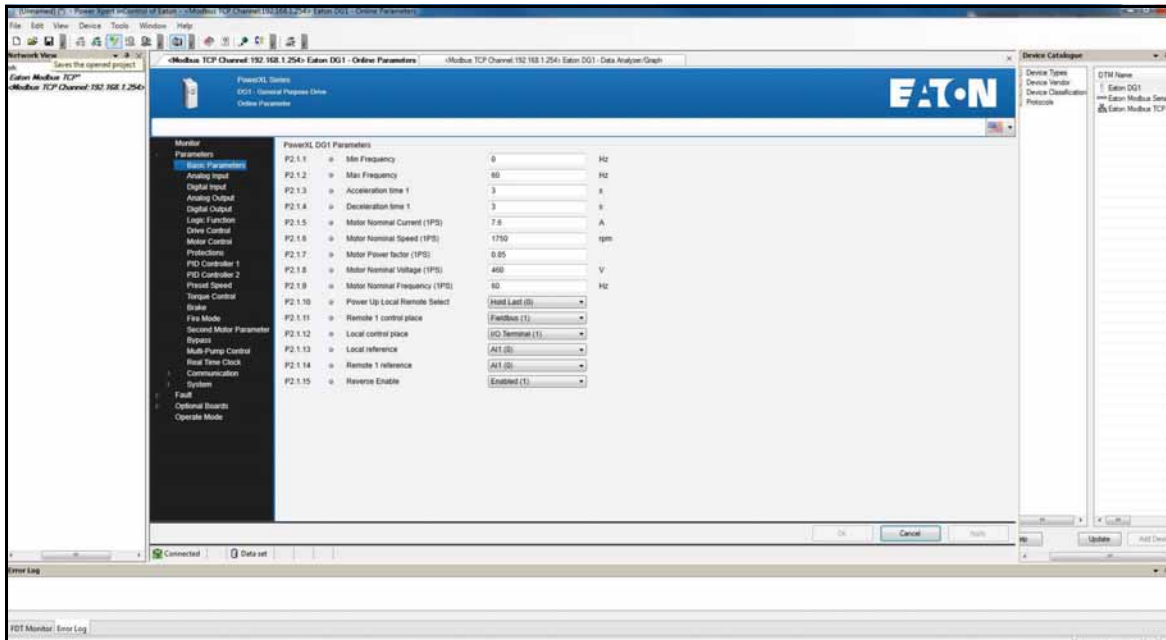
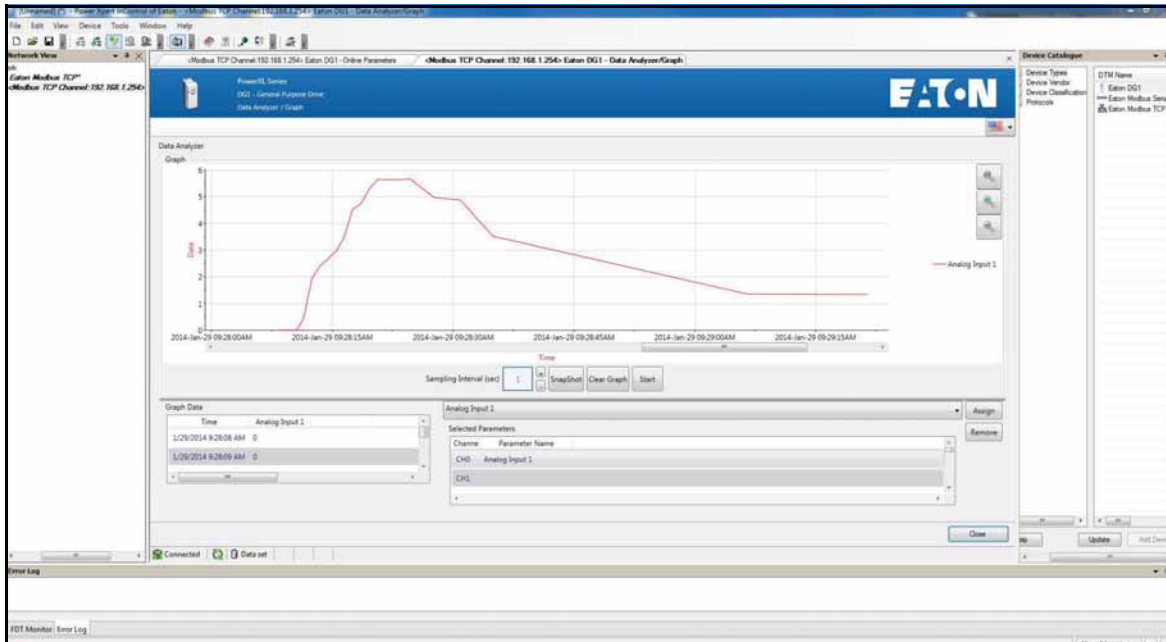

Brake Chopper Options

The brake chopper circuit option is used for applications that require dynamic braking. Dynamic braking resistors are not included with drive purchase. Consult the factory for additional dynamic braking resistor selections that are supplied separately. A list of common resistors are listed below and are complete indoor assemblies, include a pre-wired terminal block and a thermal switch, and are not UL Listed.

Duty Cycle

The duty cycle rating is based on a 60-second period. For example, the 20% duty cycle resistor can carry 100% current for 12 seconds out of every 60 seconds, while the 50% duty cycle resistor can carry 150% current for 30 seconds out of every 60 seconds.

Torque

If the braking torque required is less than 15%, dynamic braking is not required because the regenerated energy will be dissipated in the drive and motor losses.

Dynamic Brake Resistor—Catalog Number Selection

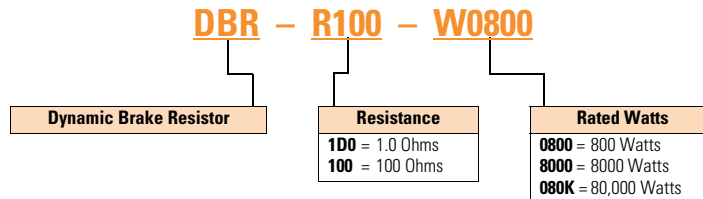

230 V Brake Resistors

Drive hp (CT/Hz)	Minimum Ohms	20% Duty Cycle, 100% Torque		50% Duty Cycle, 150% Torque	
		Catalog Number	Dimensions	Catalog Number	Dimensions
0.75	15.0	DBR-R100-W0400	12W x 5D x 5H	DBR-R100-W0800	12W x 7D x 5H
1	15.0	DBR-R100-W0400	12W x 5D x 5H	DBR-R100-W0800	12W x 7D x 5H
1.5	15.0	DBR-R100-W0400	12W x 5D x 5H	DBR-R036-W1200	12W x 10D x 5H
2	15.0	DBR-R100-W0400	12W x 5D x 5H	DBR-R036-W1200	12W x 10D x 5H
3	15.0	DBR-R036-W0800	12W x 7D x 5H	DBR-R036-W2000	12W x 16D x 5H
4	9.0	DBR-R036-W0800	12W x 7D x 5H	DBR-R012-W2400	19W x 10D x 5H
5	9.0	DBR-R036-W0800	12W x 7D x 5H	DBR-R020-W2800	19W x 13D x 5H
7.5	9.0	DBR-R020-W1200	12W x 10D x 5H	DBR-R012-W4800	26.5W x 10D x 5H
10	7.0	DBR-R015-W1600	12W x 13D x 5H	DBR-R112-W6000	26.5W x 13D x 5H
15	7.0	DBR-R012-W2400	19W x 10D x 5H	DBR-R7D8-W9000	28W x 10D x 10H
20	2.0	DBR-R9D3-W3200	19W x 10D x 5H	DBR-R3D4-W012K	28W x 10D x 10H
25	2.0	DBR-R5D5-W4000	26.5W x 10D x 5H	DBR-R5D1-W015K	28W x 16D x 10H
30	2.0	DBR-R4D8-W4800	26.5W x 10D x 5H	DBR-R4D1-W020K	28W x 16D x 10H
40	2.0	DBR-R004-W6000	26.5W x 13D x 5H	DBR-R3D4-W025K	30W x 18D x 16H
50	2.0	DBR-R3D1-W7500	26.5W x 16D x 5H	DBR-R2D1-W030K	30W x 18D x 24H
60	2.0	DBR-R2D8-W9000	26.5W x 16D x 5H	DBR-R002-W036K	30W x 18D x 24H
75	2.0	DBR-R2D6-W012K	28W x 10D x 10H	DBR-R002-W045K	30W x 18D x 32H
100	2.0	DBR-R002-W015K	28W x 16D x 10H	DBR-R002-W060K	30W x 18D x 48H

2.6

Adjustable Frequency Drives

PowerXL DG1 Series Drives

480 V Brake Resistors

2

Drive hp (CT/Hz)	Minimum Ohms	20% Duty Cycle, 100% Torque		50% Duty Cycle, 150% Torque	
		Catalog Number	Dimensions	Catalog Number	Dimensions
1	36.0	DBR-R100-W0400	12W x 5D x 5H	DBR-R100-W0800	12W x 7D x 5H
1.5	36.0	DBR-R100-W0400	12W x 5D x 5H	DBR-R100-W1200	12W x 10D x 5H
2	36.0	DBR-R100-W0400	12W x 5D x 5H	DBR-R100-W1200	12W x 10D x 5H
3	36.0	DBR-R100-W0800	12W x 7D x 5H	DBR-R100-W2000	12W x 16D x 5H
5	36.0	DBR-R100-W0800	12W x 7D x 5H	DBR-R100-W2800	19W x 13D x 5H
6	36.0	DBR-R100-W1200	12W x 10D x 5H	DBR-R070-W4000	19W x 16D x 5H
7.5	18.0	DBR-R100-W1200	12W x 10D x 5H	DBR-R020-W4800	26.5W x 13D x 5H
10	18.0	DBR-R063-W1600	12W x 13D x 5H	DBR-R030-W6000	26.5W x 16D x 5H
15	18.0	DBR-R030-W2400	19W x 10D x 5H	DBR-R030-W9000	28W x 10D x 10H
20	13.0	DBR-R030-W3200	19W x 13D x 5H	DBR-R023-W012K	28W x 13D x 10H
25	13.0	DBR-R030-W4000	19W x 16D x 5H	DBR-R013-W015K	28W x 16D x 10H
30	13.0	DBR-R020-W4800	26.5W x 13D x 5H	DBR-R014-W020K	30W x 18D x 24H
40	2.0	DBR-R112-W6000	26.5W x 13D x 5H	DBR-R007-W025K	30W x 18D x 16H
50	2.0	DBR-R013-W7500	26.5W x 16D x 5H	DBR-R8D5-W030K	30W x 18D x 24H
60	2.0	DBR-R010-W9000	28W x 10D x 10H	DBR-R7D3-W036K	30W x 18D x 24H
75	2.0	DBR-R009-W012K	28W x 13D x 10H	DBR-R002-W045K	30W x 18D x 32H
100	2.0	DBR-R5D1-W015K	28W x 16D x 10H	DBR-R004-W060K	30W x 18D x 40H
125	2.0	DBR-R4D1-W020K	28W x 16D x 10H	DBR-R004-W070K	30W x 18D x 48H
150	2.0	DBR-R3D4-W025K	30W x 18D x 16H	DBR-R3D5-W085K	30W x 18D x 56H
200	2.0	DBR-R3D3-W030K	30W x 18D x 24H	DBR-R2D6-W110K	30W x 18D x 64H

Line and Load Reactors

A line and load reactor is a three-phase inductance filter that can be placed on the line and load side of the AFD to help improve the harmonic performance of the system. Consult the factory for additional filtering options and further technical details.

DR1 Line Reactor

A line reactor helps to provide a moderate reduction in current harmonics similar to a DC choke. It also provides increased input protection for AFD and its semiconductors from line transients helping to extend the life of the AFD.

DR2 Output Reactor

An output filter is used to reduce the transient voltage (dV/dt) at the motor terminals. The output filter is recommended for cable lengths exceeding 100 ft (30 m) with a drive of 3 hp and above and for cable lengths of 33 ft (10 m) with a drive of 2 hp and below.

Line and Load Reactors—Catalog Number Selection

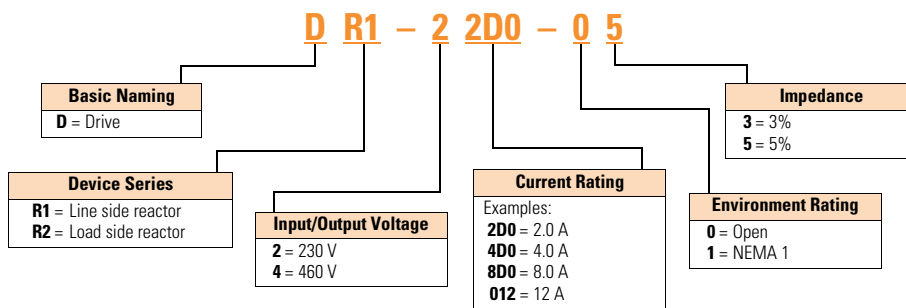

Line and Load Reactors—230 V

hp (CT)	Open		Load Reactor		NEMA 1		Load Reactor	
	3%	5%	3%	5%	3%	5%	3%	5%
0.75	DR1-23D4-03	DR1-23D4-05	DR2-24D0-03	DR2-24D0-05	DR1-23D4-13	DR1-23D4-15	DR2-24D0-13	DR2-24D0-15
1	DR1-24D8-03	DR1-24D8-05	DR2-24D0-03	DR2-28D0-05	DR1-24D8-13	DR1-24D8-15	DR2-24D0-13	DR2-28D0-15
1.5	DR1-2011-03	DR1-2011-05	DR2-28D0-03	DR2-28D0-05	DR1-2011-13	DR1-2011-15	DR2-28D0-13	DR2-28D0-15
2	DR1-27D6-03	DR1-27D6-05	DR2-28D0-03	DR2-28D0-05	DR1-27D6-13	DR1-27D6-15	DR2-28D0-13	DR2-28D0-15
3	DR1-2011-03	DR1-2011-05	DR2-2012-03	DR2-2012-05	DR1-2011-13	DR1-2011-15	DR2-2012-13	DR2-2012-15
5	DR1-2028-03	DR1-2028-05	DR2-2018-03	DR2-2018-05	DR1-2028-13	DR1-2028-15	DR2-2018-13	DR2-2018-15
7.5	DR1-2021-03	DR1-2021-05	DR2-2025-03	DR2-2025-05	DR1-2021-13	DR1-2021-15	DR2-2025-13	DR2-2025-15
10	DR1-2028-03	DR1-2028-05	DR2-2035-03	DR2-2035-05	DR1-2028-13	DR1-2028-15	DR2-2035-13	DR2-2035-15
15	DR1-2055-03	DR1-2055-05	DR2-2045-03	DR2-2045-05	DR1-2055-13	DR1-2055-15	DR2-2045-13	DR2-2045-15
20	DR1-2065-03	DR1-2065-05	DR2-2055-03	DR2-2055-05	DR1-2065-13	DR1-2065-15	DR2-2055-13	DR2-2055-15
25	DR1-2083-03	DR1-2083-05	DR2-2080-03	DR2-2080-05	DR1-2083-13	DR1-2083-15	DR2-2080-13	DR2-2080-15
30	DR1-2104-03	DR1-2104-05	DR2-2080-03	DR2-2100-05	DR1-2104-13	DR1-2104-15	DR2-2080-13	DR2-2100-15
40	DR1-2130-03	DR1-2130-05	DR2-2100-03	DR2-2100-05	DR1-2130-13	DR1-2130-15	DR2-2100-13	DR2-2100-15
50	DR1-2160-03	DR1-2160-05	DR2-2130-03	DR2-2130-05	DR1-2160-13	DR1-2160-15	DR2-2130-13	DR2-2130-15
60	DR1-2160-03	DR1-2160-05	DR2-2160-03	DR2-2200-15	DR1-2160-13	DR1-2160-15	DR2-2160-13	DR2-2200-15
75	DR1-2200-03	DR1-2200-05	DR2-2200-13	DR2-2200-15	DR1-2200-13	DR1-2200-15	DR2-2200-13	DR2-2200-15
100	DR1-2250-03	DR1-2250-05	DR2-2225-13	DR2-2225-15	DR1-2250-13	DR1-2250-15	DR2-2225-13	DR2-2225-15

2.6

Adjustable Frequency Drives

PowerXL DG1 Series Drives

Line and Load Reactors—480 V

2

hp (CT)	Open Line Reactor		Load Reactor		NEMA 1 Line Reactor		Load Reactor	
	3%	5%	3%	5%	3%	5%	3%	5%
1	DR1-42D1-03	DR1-42D1-05	DR2-42D0-05	DR2-42D0-05	DR1-42D1-13	DR1-42D1-15	DR2-42D0-13	DR2-42D0-15
1.5	DR1-44D8-03	DR1-43D4-05	DR2-44D0-05	DR2-44D0-05	DR1-44D8-13	DR1-43D4-15	DR2-44D0-13	DR2-44D0-15
2	DR1-43D4-03	DR1-43D4-05	DR2-44D0-03	DR2-44D0-05	DR1-43D4-13	DR1-43D4-15	DR2-44D0-13	DR2-44D0-15
3	DR1-44D8-03	DR1-44D8-05	DR2-48D0-03	DR2-48D0-05	DR1-44D8-13	DR1-44D8-15	DR2-48D0-13	DR2-48D0-15
5	DR1-47D6-03	DR1-47D6-05	DR2-48D0-03	DR2-48D0-05	DR1-47D6-13	DR1-47D6-15	DR2-48D0-13	DR2-48D0-15
7.5	DR1-4011-03	DR1-4011-05	DR2-4012-03	DR2-4012-05	DR1-4011-13	DR1-4011-15	DR2-4012-13	DR2-4012-15
10	DR1-4014-03	DR1-4014-05	DR2-4018-03	DR2-4018-05	DR1-4014-13	DR1-4014-15	DR2-4018-13	DR2-4018-15
15	DR1-4021-03	DR1-4021-05	DR2-4025-03	DR2-4025-05	DR1-4021-13	DR1-4021-15	DR2-4025-13	DR2-4025-15
20	DR1-4028-03	DR1-4028-05	DR2-4025-03	DR2-4025-05	DR1-4028-13	DR1-4028-15	DR2-4025-13	DR2-4025-15
25	DR1-4035-03	DR1-4035-05	DR2-4035-03	DR2-4035-05	DR1-4035-13	DR1-4035-15	DR2-4035-13	DR2-4035-15
30	DR1-4046-03	DR1-4046-05	DR2-4045-03	DR2-4045-05	DR1-4046-13	DR1-4046-15	DR2-4045-13	DR2-4045-15
40	DR1-4065-03	DR1-4055-05	DR2-4055-03	DR2-4055-05	DR1-4065-13	DR1-4055-15	DR2-4055-13	DR2-4055-15
50	DR1-4065-03	DR1-4065-05	DR2-4080-03	DR2-4080-05	DR1-4065-13	DR1-4065-15	DR2-4080-13	DR2-4080-15
60	DR1-4083-03	DR1-4083-05	DR2-4100-03	DR2-4080-05	DR1-4083-13	DR1-4083-15	DR2-4100-13	DR2-4080-15
75	DR1-4104-03	DR1-4104-05	DR2-4100-03	DR2-4100-05	DR1-4104-13	DR1-4104-15	DR2-4100-13	DR2-4100-15
100	DR1-4130-03	DR1-4130-05	DR2-4130-03	DR2-4130-05	DR1-4130-13	DR1-4130-15	DR2-4130-13	DR2-4130-15
125	DR1-4160-03	DR1-4160-05	DR2-4160-03	DR2-4160-05	DR1-4160-13	DR1-4160-15	DR2-4160-13	DR2-4160-15
150	DR1-4200-03	DR1-4200-05	DR2-4200-13	DR2-4200-15	DR1-4200-13	DR1-4200-15	DR2-4200-13	DR2-4200-15
200	DR1-4250-03	DR1-4250-05	DR2-4250-13	DR2-4250-15	DR1-4250-13	DR1-4250-15	DR2-4250-13	DR2-4250-15

Replacement Parts

Frame 1

Description	230 V	480 V	575 V
	Catalog Number	Catalog Number	Catalog Number
Standard keypad	DXG-KEY-LCD	DXG-KEY-LCD	DXG-KEY-LCD
Main control board	DXG-SPR-CTRLBOARD	DXG-SPR-CTRLBOARD	DXG-SPR-CTRLBOARD
Control module kit with keypad ①	DXG-SPR-CTRLKIT	DXG-SPR-CTRLKIT	DXG-SPR-CTRLKIT
Control board cover	DXG-SPR-BCOVER	DXG-SPR-BCOVER	DXG-SPR-BCOVER
Type 1/IP21 standard cover	DXG-SPR-FR1CVR	DXG-SPR-FR1CVR	②
Main fan kit ①	DXG-SPR-FR1FAN	DXG-SPR-FR1FAN	②
Control fan	DXG-SPR-2FR1CF	DXG-SPR-4FR1CF	②
Main power board	DXG-SPR-2FR1MPB	DXG-SPR-4FR1MPB	②
EMI board	DXG-SPR-2FR1EB	DXG-SPR-4FR1EB	②
Middle chassis cover	DXG-SPR-FR1MCC	DXG-SPR-FR1MCC	②
Outer housing	DXG-SPR-FR1OH	DXG-SPR-FR1OH	②
UL conduit plate	DXG-SPR-FR1CPUL	DXG-SPR-FR1CPUL	②
IEC conduit plate	DXG-SPR-FR1CPIEC	DXG-SPR-FR1CPIEC	②

Frame 2

Description	230 V	480 V	575 V
	Catalog Number	Catalog Number	Catalog Number
Standard keypad	DXG-KEY-LCD	DXG-KEY-LCD	DXG-KEY-LCD
Main control board	DXG-SPR-CTRLBOARD	DXG-SPR-CTRLBOARD	DXG-SPR-CTRLBOARD
Control module kit with keypad ①	DXG-SPR-CTRLKIT	DXG-SPR-CTRLKIT	DXG-SPR-CTRLKIT
Control board cover	DXG-SPR-BCOVER	DXG-SPR-BCOVER	DXG-SPR-BCOVER
Type 1/IP21 standard cover	DXG-SPR-FR2CVR	DXG-SPR-FR2CVR	②
Main fan kit ①	DXG-SPR-FR2FAN	DXG-SPR-FR2FAN	②
Control fan	DXG-SPR-FR2CF	DXG-SPR-FR2CF	②
Bus capacitor	DXG-SPR-2FR2BC	DXG-SPR-4FR24BC	②
Main power board	DXG-SPR-2FR2MPB	DXG-SPR-4FR2MPB	②
EMI board	DXG-SPR-2FR2EB	DXG-SPR-4FR2EB	②
IGBT module	DXG-SPR-FR2IGBT	DXG-SPR-FR2IGBT	②
Middle chassis cover	DXG-SPR-FR2MCC	DXG-SPR-FR2MCC	②
Outer housing	DXG-SPR-FR2OH	DXG-SPR-FR2OH	②
UL conduit plate	DXG-SPR-FR2CPUL	DXG-SPR-FR2CPUL	②
IEC conduit plate	DXG-SPR-FR2CPIEC	DXG-SPR-FR2CPIEC	②

Notes

① Factory recommended spare parts.

② 575 V available in May 2015.

2.6

Adjustable Frequency Drives

PowerXL DG1 Series Drives

Frame 3

2

Description	230 V Catalog Number	480 V Catalog Number	575 V Catalog Number
Standard keypad	DXG-KEY-LCD	DXG-KEY-LCD	DXG-KEY-LCD
Main control board	DXG-SPR-CTRLBOARD	DXG-SPR-CTRLBOARD	DXG-SPR-CTRLBOARD
Control module kit with keypad ①	DXG-SPR-CTRLKIT	DXG-SPR-CTRLKIT	DXG-SPR-CTRLKIT
Control board cover	DXG-SPR-BCOVER	DXG-SPR-BCOVER	DXG-SPR-BCOVER
Type 1/IP21 standard cover	DXG-SPR-FR3CVR	DXG-SPR-FR3CVR	②
Main fan kit ①	DXG-SPR-FR3FANKIT	DXG-SPR-FR3FANKIT	②
Main fan	DXG-SPR-FR3FAN	DXG-SPR-FR3FAN	②
Control fan	DXG-SPR-FR34CF	DXG-SPR-FR34CF	②
Bus capacitor	DXG-SPR-FR3BC	DXG-SPR-FR3BC	②
Main power board	DXG-SPR-2FR3MPB	DXG-SPR-4FR3MPB	②
EMI board	DXG-SPR-2FR3EB	DXG-SPR-4FR3EB	②
Drive board	DXG-SPR-2FR3DB	DXG-SPR-4FR3DB	②
Output board	DXG-SPR-FR3OB	DXG-SPR-FR3OB	②
Middle chassis cover	DXG-SPR-FR3MCC	DXG-SPR-FR3MCC	②
Outer housing	DXG-SPR-FR3OH	DXG-SPR-FR3OH	②
UL conduit plate	DXG-SPR-FR3CPUL	DXG-SPR-FR3CPUL	②
IEC conduit plate	DXG-SPR-FR3CPIEC	DXG-SPR-FR3CPIEC	②

Frame 4

Description	230 V Catalog Number	480 V Catalog Number	575 V Catalog Number
Standard keypad	DXG-KEY-LCD	DXG-KEY-LCD	DXG-KEY-LCD
Main control board	DXG-SPR-CTRLBOARD	DXG-SPR-CTRLBOARD	DXG-SPR-CTRLBOARD
Control module kit with keypad ①	DXG-SPR-CTRLKIT	DXG-SPR-CTRLKIT	DXG-SPR-CTRLKIT
Control board cover	DXG-SPR-BCOVER	DXG-SPR-BCOVER	DXG-SPR-BCOVER
Type 1/IP21 standard cover	DXG-SPR-FR4CVR	DXG-SPR-FR4CVR	②
Main fan kit ①	DXG-SPR-FR4FANKIT	DXG-SPR-FR4FANKIT	②
Main fan	DXG-SPR-FR4FAN	DXG-SPR-FR4FAN	②
Control fan	DXG-SPR-FR34CF	DXG-SPR-FR34CF	②
Bus capacitor	DXG-SPR-2FR4BC	DXG-SPR-4FR24BC	②
Main power board	DXG-SPR-2FR4MPB	DXG-SPR-4FR4MPB	②
EMI board	DXG-SPR-2FR4EB	DXG-SPR-4FR4EB	②
Softstart board	DXG-SPR-2FR4SB	DXG-SPR-4FR4SB	②
IGBT module	DXG-SPR-2FR4IGBT	DXG-SPR-4FR4IGBT	②
Rectifier module	DXG-SPR-2FR4RM	DXG-SPR-4FR4RM	②
Brake chopper module	DXG-SPR-2FR4BCM	DXG-SPR-4FR4BCM	②
Middle chassis cover	DXG-SPR-FR4MCC	DXG-SPR-FR4MCC	②
Outer housing	DXG-SPR-FR4OH	DXG-SPR-FR4OH	②
UL conduit plate	DXG-SPR-FR4CPUL	DXG-SPR-FR4CPUL	②
IEC conduit plate	DXG-SPR-FR4CPIEC	DXG-SPR-FR4CPIEC	②

Notes

① Factory recommended spare parts.

② 575 V available in May 2015.

Frame 5

Description	230 V Catalog Number	480 V Catalog Number	575 V Catalog Number
Standard keypad	DXG-KEY-LCD	DXG-KEY-LCD	DXG-KEY-LCD
Main control board	DXG-SPR-CTRLBOARD	DXG-SPR-CTRLBOARD	DXG-SPR-CTRLBOARD
Control module kit with keypad ^①	DXG-SPR-CTRLKIT	DXG-SPR-CTRLKIT	DXG-SPR-CTRLKIT
Control board cover	DXG-SPR-BCOVER	DXG-SPR-BCOVER	DXG-SPR-BCOVER
Type 1/IP21 standard cover	DXG-SPR-FR5CVR	DXG-SPR-FR5CVR	②
Main fan kit ^①	DXG-SPR-FR5FANKIT	DXG-SPR-FR5FANKIT	②
Main fan	DXG-SPR-FR5FAN	DXG-SPR-FR5FAN	②
Control fan	DXG-SPR-FR5CF	DXG-SPR-FR5CF	②
Bus capacitor	DXG-SPR-FR5BC	DXG-SPR-FR5BC	②
Main power board	DXG-SPR-2FR5MPB	DXG-SPR-4FR5MPB	②
EMI-1 board	DXG-SPR-2FR5E1B	DXG-SPR-4FR5E1B	②
EMI-2 board	DXG-SPR-2FR5E2B	DXG-SPR-4FR5E2B	②
EMI-3 board	DXG-SPR-FR5E3B	DXG-SPR-FR5E3B	②
IGBT module	DXG-SPR-FR5IGBT	DXG-SPR-FR5IGBT	②
Rectifier module	DXG-SPR-2FR5RM	DXG-SPR-4FR5RM	②
Brake chopper module	DXG-SPR-2FR5BCM	DXG-SPR-4FR5BCM	②
Middle chassis cover	DXG-SPR-FR5MCC	DXG-SPR-FR5MCC	②
Outer housing	DXG-SPR-FR5OH	DXG-SPR-FR5OH	②
UL conduit plate	DXG-SPR-FR5CPUL	DXG-SPR-FR5CPUL	②
IEC conduit plate	DXG-SPR-FR5IECCP	DXG-SPR-FR5IECCP	②

Notes

- ① Factory recommended spare parts.
 ② 575 V available in May 2015.

Technical Data and Specifications

PowerXL Series—DG1 Technical Data and Specifications

2

Attribute	Description	Specification	
Input ratings	Input voltage U_{in}	208 V to 240 V, 380 V to 500 V, 525 V to 600 V, –15 to 10%	
	Input frequency	50 Hz to 60 Hz (variation up to 45 Hz to 66 Hz)	
	Connection to power	Once per minute or less	
	Starting delay	3 s (FR1 to FR2), 4 s (FR3), 5 s (FR4), 6 s (FR5 and FR6)	
	Short-circuit withstand rating	100 kAIC (fuses and circuit breakers)	
Output ratings	Output voltage	0 to U_{in}	
	Continuous output current	I_L : ambient temperature maximum 40 °C, up to 60 °C with derating, overload 1.1 x I_L (1 min./10 min.) I_H : ambient temperature maximum 50 °C, up to 60 °C with derating, overload 1.5 x I_H (1 min./10 min.)	
	Overload current	150% respectively 110% (1 min./10 min.)	
	Initial output current	200% (2 s / 20 s)	
	Output frequency	0–400 Hz (standard)	
	Frequency resolution	0.01 Hz	
Control characteristics	Control methods	Frequency control Speed control Open-loop speed control Open-loop torque control	
	Switching frequency	230 V / 480 V range: FR1–3: 1 kHz to 12 kHz FR4–6: 1 kHz to 10 kHz 230 V / 480 V defaults: FR1–3: 4 kHz FR4–5: 3.6 kHz FR6: 2 kHz 575 V range: FR1–6: 1 kHz to 6 kHz 575 V defaults: FR1–4: 3 kHz FR5–6: 2 kHz Automatic switching frequency derating in case of overload.	
	Frequency reference	Analog input: resolution 0.1% (10-bit), accuracy +1% Analog output: resolution 0.1% (10-bit), accuracy +1% Panel reference: resolution 0.01 Hz	
	Field weakening point	20 Hz to 400 Hz	
	Acceleration time	0.1 s to 3000 s	
	Deceleration time	0.1 s to 3000 s	
	Braking torque	DC brake: 30% x Motor Rated Torque (T_n) (without brake chopper) Dynamic braking (with optional brake chopper using an external brake resistor): 100% continuous maximum rating	
	Ambient conditions	Ambient operating temperature	–10 °C (no frost) to +50 °C, up to +60 °C with derating (CT) –10 °C (no frost) to +40 °C, up to +60 °C with derating (VT)
		Storage temperature	–40 °C to +70 °C
		Relative humidity	0–95% RH, noncondensing, non-corrosive
Air quality: • Chemical vapors • Mechanical particles		Tested according to IEC 60068-2-60 Test Key: Flowing mixed gas corrosion test, Method 1 (H2S [hydrogen sulfide] and SO2 [sulfur dioxide]) Designed according to: IEC 60721-3-3, unit in operation, class 3C2 IEC 60721-3-3, unit in operation, class 3S2	
Altitude		100% load capacity (no derating) up to 3280 ft (1000 m); 1% derating for each 328 ft (100 m) above 3280 ft (1000 m); max. 9842 ft (3000 m) (2000 m for corner grounded earth main systems) For 575 V product, maximum altitude is 6561 ft (2000 m) regardless of main system	

PowerXL Series—DG1 Technical Data and Specifications, continued

Attribute	Description	Specification
Ambient conditions, continued	Vibration:	5–150 Hz
	• EN 61800-5-1	Displacement amplitude: 1 mm (peak) at 5 Hz to 15.8 Hz (FR1–FR6)
	• EN 60668-2-6	Maximum acceleration amplitude: 1g at 15.8 Hz to 150 Hz (FR1–FR6)
	Shock:	Storage and shipping: maximum 15 g, 11 ms (in package)
	• ISTA 1 A	
	• EN 60068-2-27	
	Overvoltage	Overvoltage Category III
	Pollution degree	Pollution Degree 2
	Enclosure class	IP21/Type 1 standard in entire kW/hp range IP54/Type 12 option Note: Keypad or keypad hole plug required to be mounted in drive for IP54/Type 12 rating
	Immunity	Fulfills EN 61800-3 (2004), first and second environment
MTBF		FR1: 165,457 hours
		FR2: 134,833 hours
		FR3: 102,515 hours
		FR4: 121,567 hours
		FR5: 108,189 hours
		FR6: Available in 2016
Noise		FR1: 51.2 dB
		FR2: 58.6 dB
		FR3: 61.0 dB
		FR4: 68.0 dB
		FR5: 69.1 dB
		FR6: Available in 2016
Standards	Safety	UL 508C, CSA C22.2 No. 274-13 and EN 61800-5-1
	EMC	+EMC2: EN 61800-3 (2004), Category C2 The drive can be modified for IT networks and corner grounding TN system
	Electrostatic discharge	Second environment, IEC 61000-4-2, 4 kV CD or 8 kV AD, Criterion B
	Fast transient burst	Second environment, IEC 61000-4-4, 2 kV/5 kHz, Criterion B
	Dielectrical strength	Primary to secondary: 3600 Vac/5100 Vdc Primary to earth: 2000 Vac/2828 Vdc
	Approvals	EAC, RCM (C-Tick), RoHS, CE, UL and cUL (see nameplate for more detailed approvals)
Fieldbus connections	Onboard: EtherNet/IP, Modbus® TCP, Modbus RTU, BACnet	

2.6

Adjustable Frequency Drives

PowerXL DG1 Series Drives











PowerXL Series—DG1 Technical Data and Specifications, continued

2

Attribute	Description	Specification
Safety/protections	Overvoltage protection	Yes
	Overvoltage trip limit	230 V drives: 456 V 480 V drives: 911 V 575 V drives: 1100 V
	Undervoltage protection	Yes
	Undervoltage trip limit	230 V drives: 211 V 480 V drives: 370 V 575 V drives: 550 V
	Earth fault protection	Yes Default: 15% motor FLA Minimum: 0% motor FLA Maximum: 30% motor FLA
	Input phase supervision	Yes
	Motor phase supervision	Yes
	Overcurrent protection	Yes
	Unit overtemperature protection	Yes
	Motor overload protection	Yes
	Motor stall protection	Yes
	Motor underload protection	Yes
	DC bus overvoltage control	Yes
	Short-circuit protection of 24 V reference voltages	Yes
	Surge protection	Yes (differential mode 2 kV; common mode 4 kV 230 V drives: 275 Vac, 10,000 A 480 V drives: 320 Vac, 8000 A 575 V drives: 385 Vac, 10,000 A
Common coated boards	Yes (prevents corrosion)	
Efficiency	Drive efficiency ratings	480 V: FR1 = 97.7% FR2 = 97.9% FR3 = 97.7% FR4 = 98.0% FR5 = 98.2%
		230 V: FR1 = 96.7% FR2 = 97.4% FR3 = 97.2% FR4 = 97.4% FR5 = 97.7%

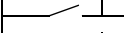
Wiring Diagram

PowerXL Series—DG1 Control Wiring Diagram

External Wiring	Pin	Signal Name	Signal	Default Setting	Description
	1	+10 V	Ref. Output Voltage	—	10 Vdc Supply Source
	2	AI1+	Analog Input 1	0–10 V	Voltage Speed Reference (Programmable to 4 mA to 20 mA)
	3	AI1–	Analog Input 1 Ground	—	Analog Input 1 Common (Ground)
	4	AI2+	Analog Input 2	4 mA to 20 mA	Current Speed Reference (Programmable to 0–10 V)
	5	AI2–	Analog Input 2 Ground	—	Analog Input 2 Common (Ground)
	6	GND	I/O Signal Ground	—	I/O Ground for Reference and Control
	7	DIN5	Digital Input 5	Preset Speed B0	Sets frequency output to Preset Speed 1
	8	DIN6	Digital Input 6	Preset Speed B1	Sets frequency output to Preset Speed 2
	9	DIN7	Digital Input 7	—	—
	10	DIN8	Digital Input 8	Force Remote (TI+)	Input takes VFD from Local to Remote
	11	CMB	DI5 to DI8 Common	Grounded	Allows source input
	12	GND	I/O Signal Ground	—	I/O Ground for Reference and Control
	13	24 V	+24 Vdc Output	—	Control voltage output (100 mA max.)
	14	DO1	Digital Output 1	Ready	Shows the drive is ready to run
	15	24 Vo	+24 Vdc Output	—	Control voltage output (100 mA max.)
	16	GND	I/O Signal Ground	—	I/O Ground for Reference and Control
	17	AO1+	Analog Output 1	Output Frequency	Shows Output frequency to motor 0–60 Hz (4 mA to 20 mA)
	18	AO2+	Analog Output 2	Motor Current	Shows Motor current of motor 0–FLA (4 mA to 20 mA)
	19	24 Vi	+24 Vdc Input	—	External control voltage input
	20	DIN1	Digital Input 1	Run Forward	Input starts drive in forward direction (start enable)
	21	DIN2	Digital Input 2	Run Reverse	Input starts drive in reverse direction (start enable)
	22	DIN3	Digital Input 3	External Fault	Input causes drive to fault
	23	DIN4	Digital Input 4	Fault Reset	Input resets active faults
	24	CMA	DI1 to DI4 Common	Grounded	Allows source input
	25	A	RS-485 Signal A	—	Fieldbus Communication (Modbus, BACnet)
	26	B	RS-485 Signal B	—	Fieldbus Communication (Modbus, BACnet)
	27	R3NO	Relay 3 Normally Open	At Speed	Relay output 3 shows VFD is at Ref. Frequency
	28	R1NC	Relay 1 Normally Closed	Run	Relay output 1 shows VFD is in a run state
	29	R1CM	Relay 1 Common		
	30	R1NO	Relay 1 Normally Open		
	31	R3CM	Relay 3 Common	At Speed	Relay output 3 shows VFD is at Ref. Frequency
	32	R2NC	Relay 2 Normally Closed	Fault	Relay output 2 shows VFD is in a fault state
	33	R2CM	Relay 2 Common		
	34	R2NO	Relay 2 Normally Open		

Notes

The above wiring demonstrates a SINK configuration. It is important that CMA and CMB are wired to ground (as shown by dashed line).

If a SOURCE configuration is desired, wire 24 V to CMA and CMB and close the inputs to ground.

When using the +10 V for AI1, it is important to wire AI1– to ground (as shown by dashed line).

If using +10 V for AI1 or AI2, terminals 3, 5 and 6 need to be jumpered together.

2.6

Adjustable Frequency Drives

PowerXL DG1 Series Drives

Control Board Layout

PowerXL Series—DG1 Control Board Layout

2

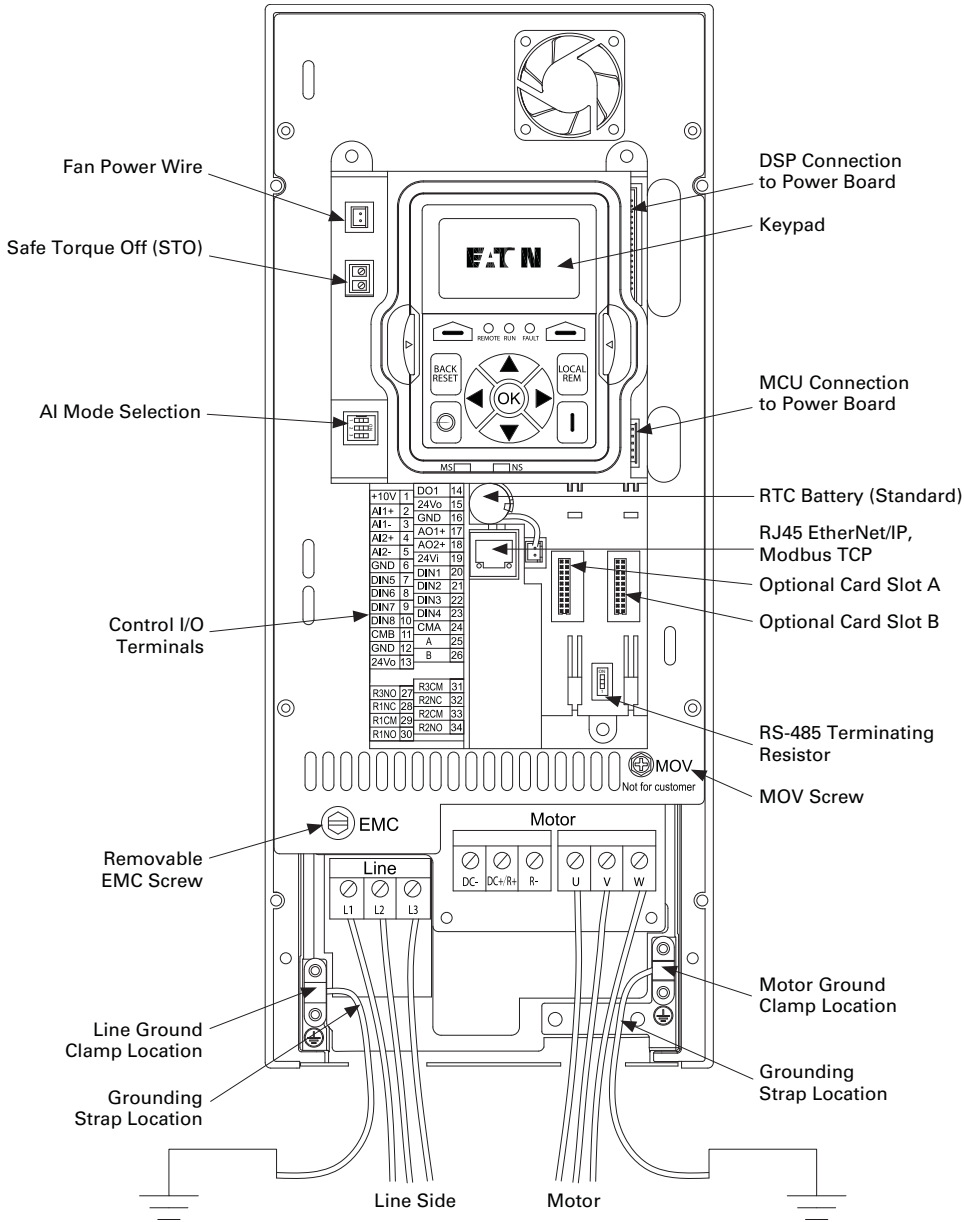

Dimensions

Approximate Dimensions in Inches (mm)

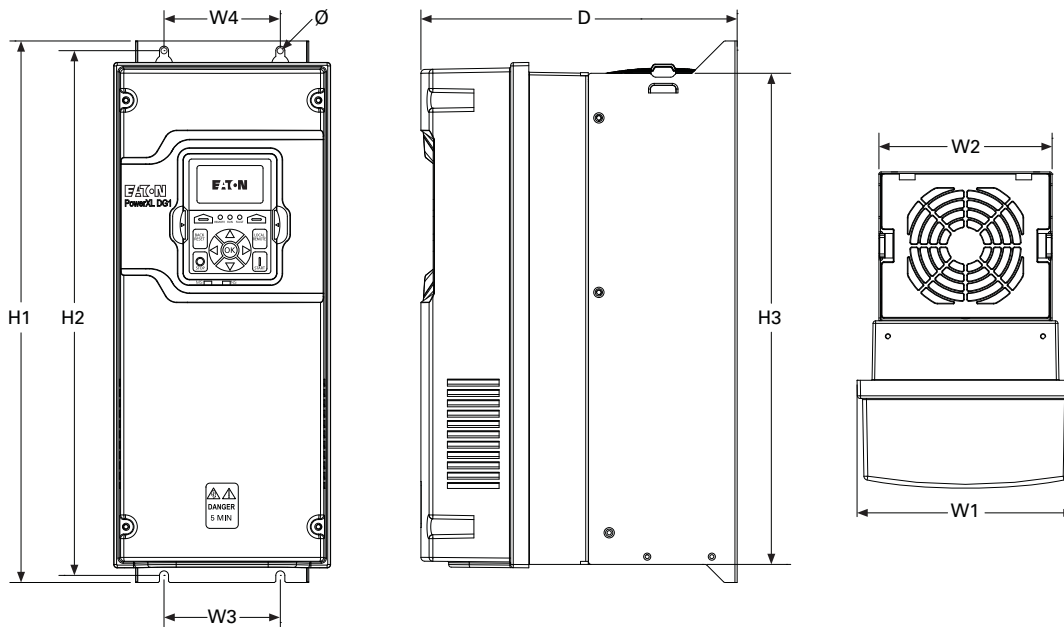
PowerXL Series—DG1 Dimensions

Frame Size	Voltage	hp (CT/I _H)	kW	Amperes (CT/I _H)	Approximate Dimensions in Inches (mm)								Weight Lb (kg)	
					D	H1	H2	H3	W1	W2	W3	W4		Ø
FR1	230 Vac	0.75–3	0.55–2.2	3.5–11	7.91	12.87	12.28	11.50	6.02	4.80	3.94	3.94	0.28	14.33
	480 Vac	1–5	0.75–3.7	2.3–7.6	(200.9)	(326.9)	(311.9)	(292.1)	(153.0)	(121.9)	(100.1)	(100.1)	(7.0)	(6.5)
	575 Vac ^①	2–5	1.5–3.7	3.3–7.5										
FR2	230 Vac	5–7.5	3–5.5	12.5–25	9.63	16.50	15.98	14.96	6.61	5.28	3.54	3.54	0.28	23.37
	480 Vac	7.5–15	5.5–11	12–23	(244.7)	(419.1)	(405.9)	(380.0)	(167.8)	(134.1)	(90.0)	(90.0)	(7.0)	(10.6)
	575 Vac ^①	7.5–15	5.5–11	10–18										
FR3	230 Vac	10–15	7.5–11	31–48	10.44	21.97	21.46	20.41	8.06	7.24	4.92	4.92	0.35	49.82
	480 Vac	20–30	15–22	31–46	(265.1)	(558.0)	(545.0)	(518.5)	(204.6)	(183.9)	(125.0)	(125.0)	(9.0)	(22.6)
	575 Vac ^①	20–30	15–22	22–34										
FR4	230 Vac	20–30	15–22	61–88	11.57	24.80	24.31	23.27	9.36	9.13	8.07	8.07	0.35	77.60
	480 Vac	40–60	30–45	61–87	(294.0)	(629.9)	(617.5)	(591.1)	(237.7)	(231.9)	(205.0)	(205.0)	(9.0)	(35.2)
	575 Vac ^①	40–60	30–45	41–62										
FR5	230 Vac	40–60	30–45	114–170	13.41	34.98	29.65	27.83	11.34	11.10	8.66	8.66	0.35	154.32
	480 Vac	75–125	55–90	105–170	(340.7)	(888.5)	(753.1)	(706.9)	(288.0)	(281.9)	(220.0)	(220.0)	(9.0)	(70.0)
	575 Vac ^①	75–125	55–90	80–125										
FR6 ^②	230 Vac	75–100	55–75	211–248	②	②	②	②	②	②	②	②	②	②
	480 Vac	150–200	110–150	205–261										
	575 Vac	150–200	110–160	144–208										

Notes

① 575 V available in May 2015.

② FR6 available in 2016.