

Agilent AEDS-962x for 150 LPI Ultra Small Optical Encoder Modules Data Sheet

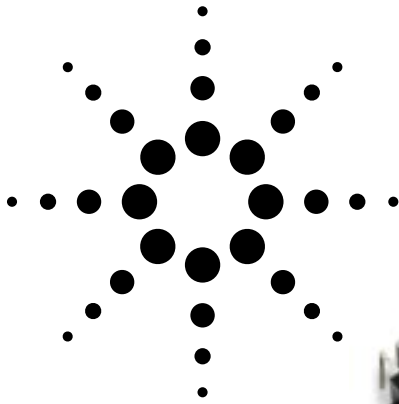

Description

This is a very small, low package height and high performance incremental encoder module. When operated in conjunction with either a codewheel or codestrip, this module detects rotary or linear position. The encoder consists of a lensed LED source and a detector IC enclosed in a small C-shaped plastic package. Due to a highly collimated light source and a unique photodetector array, the module is extremely tolerant to mounting misalignment.

The two-channel digital outputs and 3.3 V or 5.0 V supply input are accessed through four solder plated leads located on 2.00 mm (0.1 inch) centers. The supply input of the LED, rated at 16 mA, is accessed through two leads located at 2.54 mm.

It is designed for use with an 11.00 mm optical radius codewheel or linear codestrip. Other options are available. Please contact the factory for more information.

Applications

The AEDS-962x provides sophisticated motion detection, making closed-loop control very cost effective. Typical applications include printers, plotters, copiers, and office automation equipment.

Note: Agilent Technologies' encoders are not recommended for use in safety critical applications, eg., ABS braking systems and critical-care medical equipment. Please contact a sales representative if more clarification is needed.

Theory of Operation

The AEDS-962x is a C-shaped emitter/detector module. Coupled with a codewheel, it translates rotary motion into a two-channel digital output. Coupled with a codestrip, it translates linear motion into digital outputs.

As seen in Figure 1, the module contains a single Light Emitting Diode (LED) as its light source.

Features

- Very small
- Low package height
- Built-in codewheel and codestrip guide bumps
- Wide resolution range
- For linear and rotary applications
- No signal adjustment required
- Insensitive to radial and axial play
- 0°C to +70°C operating temperature
- Two-channel quadrature output
- TTL 3.3 V or 5.0 V CMOS compatible
- Wave solderable

The light is collimated into a parallel beam by means of a single lens located directly over the LED. Opposite the emitter is the integrated detector circuit.

This IC consists of multiple sets of photodetectors and the signal processing circuitry necessary to produce the digital waveforms.

The codewheel/codestrip moves between the emitter and detector, causing the light beam to be interrupted by the pattern of spaces and bars on the codewheel/codestrip. The photodiodes which detect these interruptions are arranged in a pattern that corresponds to the radius and count density of the codewheel/codestrip. These detectors are also spaced such that a light period on one pair of

ESD WARNING: NORMAL HANDLING PRECAUTIONS SHOULD BE TAKEN TO AVOID STATIC DISCHARGE.



Agilent Technologies

detectors corresponds to a dark period on the adjacent pair of detectors. The photodiode outputs are fed through the signal processing circuitry. Two comparators receive these signals and produce the final outputs for channels A and B. Due to this integrated phasing technique, the output of channel A is in quadrature with channel B (90 degrees out of phase).

Definitions

Note: Refer to Figure 2.

Count (N) = The number of bar and window pairs or counts per revolution (CPR) of the codewheel.

One Cycle (C)
 = 360 electrical degrees (°e)
 = 1 bar and window pair

One Shaft Rotation
 = 360 mechanical degrees
 = N cycles
 each state width from its ideal value of 90°e.

Pulse Width (P): The number of electrical degrees that an output is high during one cycle. This value is nominally 180°e or 1/2 cycle.

Pulse Width Error (ΔP): The deviation, in electrical degrees, of the pulse width from its ideal value of 180°e.

State Width (S): The number of electrical degrees between a transition in the output of channel A and the neighboring transition in the output of channel B. There are 4 states per cycle, each nominally 90°e.

State Width Error (ΔS): The deviation, in electrical degrees, of each state width from its ideal value of 90°e.

Phase (φ): The number of electrical degrees between the center of the high state of channel A and the center of the high state of channel B.

Phase Error (Δφ): The deviation of the phase from its ideal value of 90°e.

Direction of Rotation: When the codewheel rotates in the counterclockwise direction (as viewed from the encoder end of the motor), channel A will lead channel B. If the codewheel rotates in the clockwise direction, channel B will lead channel A.

Optical Radius (R_{OP}): The distance from the codewheel's center of rotation to the optical center (O.C.) of the encoder module.

Angular Misalignment Error (E_A): Angular misalignment of the sensor in relation to the tangential direction. This applies for both rotary and linear motion.

Mounting Position (R_M): The distance from motor shaft center of rotation to center of alignment tab receiving hole.

Absolute Maximum Ratings

Parameter	Symbol	Min.	Max.	Units	Notes
Storage Temperature	T _S	-40	85	°C	
Operating Temperature	T _A	0	70	°C	
Supply Voltage (Detector)	V _{CC}	-0.5	7	V	
Output Voltage	V _O	-0.5	V _{CC}	V	
Output Current per Channel	I _O	-1.5	10	mA	
Soldering Temperature			260	°C	t ≤ 5 sec.
DC Forward Current (LED)	I _{LED}		50	mA	V _F < 1.8 V
Reverse Voltage	V _R		5	V	I _R = 100 μA

Recommended Operating Conditions

Parameter	Symbol	Min.	Typ.	Max.	Units	Notes
Temperature	T_A	0	25	70	°C	
Supply Voltage (Detector)	V_{CC}	2.8	3.3 or 5.0	5.2	V	Ripple < 100 mV p-p
Load Capacitance	C_L		none	100	pF	
Pullup Resistor	R_{PULL}		none		k Ω	Recommend no pullup. Device has integrated 2.5 K Ω on outputs.
Count Frequency	f			20	kHz	Velocity (rpm) x N/60
Angular Misalignment Error	E_A	-3.0	0.0	+3.0	deg.	Mounting Considerations
Mounting Position	R_M		$R_{OP} - 2.4$ ($R_{OP} - 0.095"$)		mm (inch)	*Refer to Mounting Considerations
DC Forward Current (LED) @ $V_{CC} = 5.0$ V	I_{LED}	10	16	20		Recommended 210 Ω ($\pm 10\%$) series resistor between 5.0 V supply and V_{LED} .
DC Forward Current (LED) @ $V_{CC} = 3.3$ V	I_{LED}	10	16	20		Recommended 110 Ω ($\pm 10\%$) series resistor between 3.3 V supply and V_{LED} .

Electrical Characteristics

Electrical Characteristics over Recommended Operating Range, Typical at 25°C.

Parameter	Symbol	Min.	Typ. @ 3.3 V	Typ. @ 5.0 V	Max.	Units	Notes
Supply Current (Detector)	I_{CC}	2	3.5	5	10	mA	
High Level Output Voltage	V_{OH}	2.4	3	5	5.2	V	Typical $I_{OH} = -1.0$ mA @ 5.0 V Typical $I_{OH} = -0.7$ mA @ 3.3 V
Low Level Output Voltage	V_{OL}				0.4	V	Typical $I_{OH} = 10$ mA @ 5.0 V Typical $I_{OH} = 8$ mA @ 3.3 V
Rise Time	t_r		200	200		ns	$C_L = 25$ pF, $R_L = 11$ k Ω
Fall Time	t_f		50	50		ns	
LED Forward Voltage	V_F		1.52	1.52	1.54	V	

Note: Refer to Figure 2 for output waveform on t_r and t_f .

Encoding Characteristics

Encoding Characteristics Over the Recommended Operating Conditions and Mounting Conditions.

These characteristics do not include codewheel/codestrip contribution. The typical values are averages over the full rotation of the codewheel.

Parameter	Symbol	Typical	Maximum	Units
Pulse Width Error	ΔP	7	40	°e
Logic State Width Error	ΔS	5	40	°e
Phase Error	$\Delta \phi$	2	15	°e

Note: Recommended no pullup. Device has integrated 2.5 k Ω pullup resistor on Channel A & Channel B outputs.

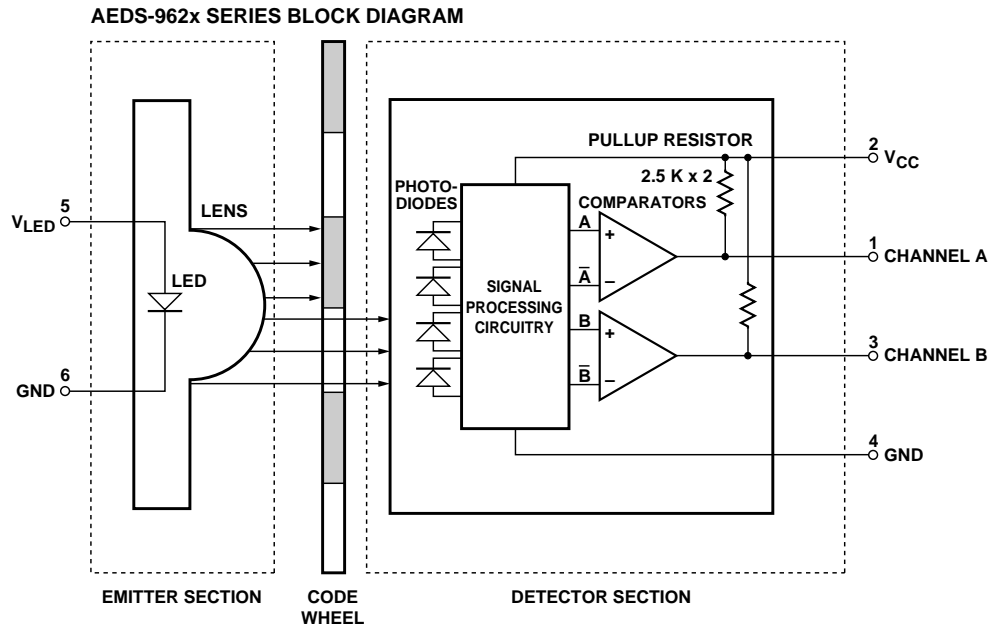

Figure 1.

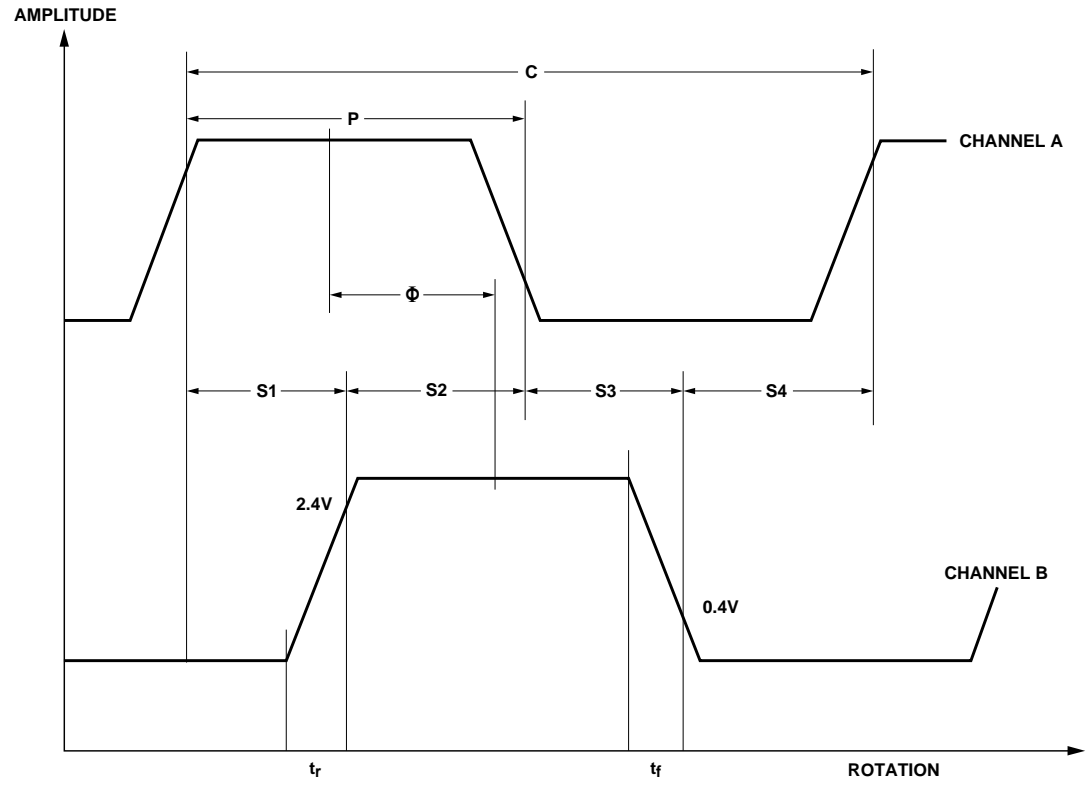

Figure 2.

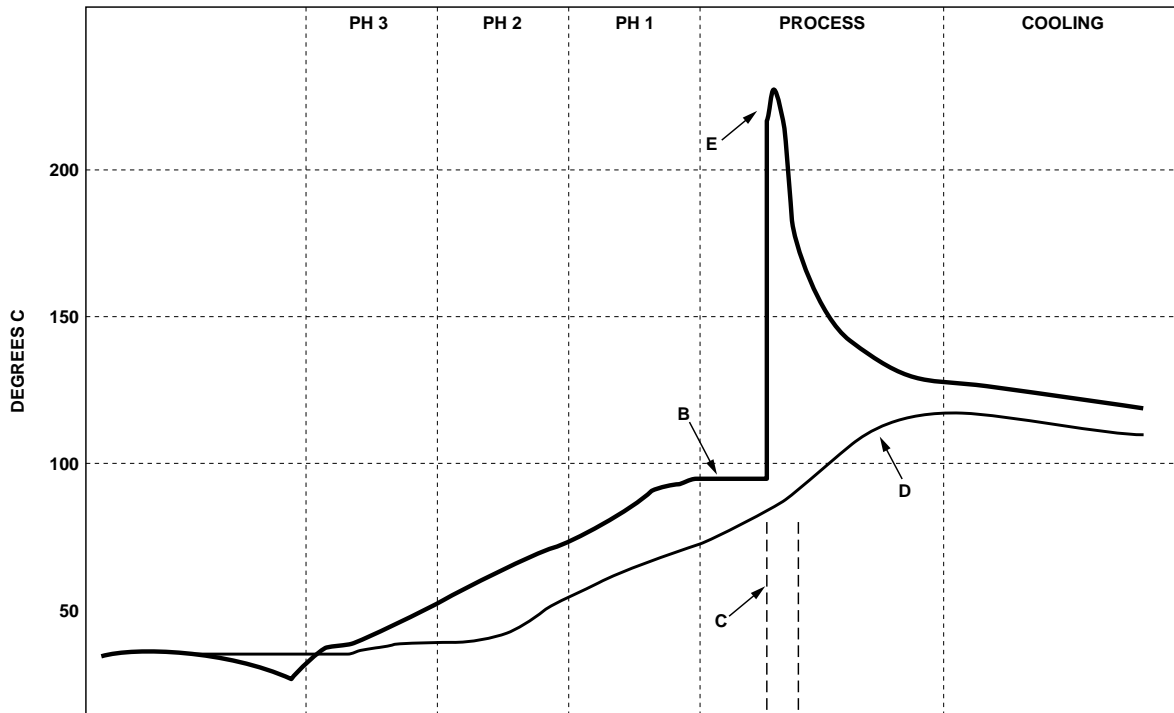
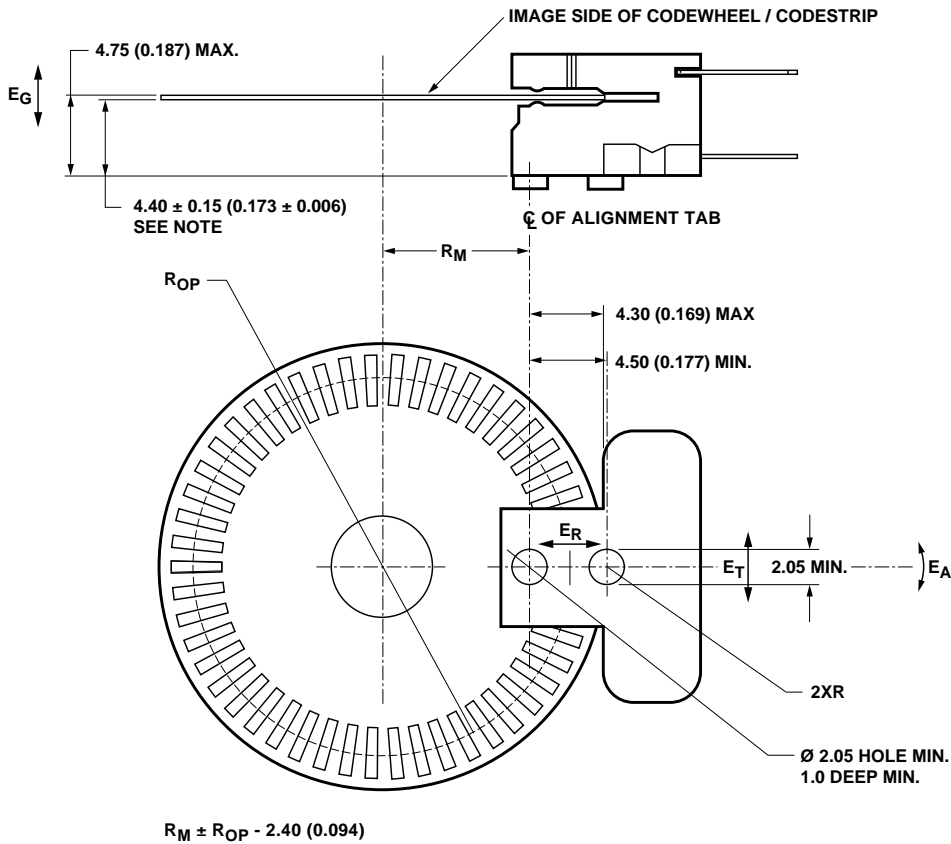

Figure 3. Recommended wave solder profile.

	Parameter	Min.	Max.	Nominal Values	Units
A	Solder Pot Temperature	NA	260	240 - 250	°C
B	Preheat Zone Temperature	85	110	90 - 105	°C
C	Dip in Time	2.5	5.0	2.5 - 4.5	sec
D	Solder Pot Zone (PCB Top)	NA	160	<160	°C
E	Solder Pot Zone (Encoder Lead)	200	NA	≥ 200	°C

Notes:

1. Nominal values are evaluated profiles for optimum performance.
2. Min./Max. are critical limits to ensure encoders in good condition.



NOTE:
 THESE DIMENSIONS INCLUDE SHAFT END PLAY AND CODEWHEEL WARP.
 ALL DIMENSIONS FOR MOUNTING IN THE MODULE AND CODEWHEEL/CODESTRIP
 SHOULD BE MEASURED WITH RESPECT TO THE TWO MOUNTING POSTS SHOWN ABOVE.

Figure 4. Mounting consideration.

Error	Symbol	Rop = 11.00 mm	Unit	Notes
Gap	E_G	± 0.15	mm	Recommend CW be put closer to the detector side (upper side), in order to keep enough margin for encoder operation.
Radial	E_R	± 0.13	mm	
Tangential	E_T	± 0.13	mm	
Angular	E_A	± 3	$^\circ C$	

Package Dimensions
AEDS-9621

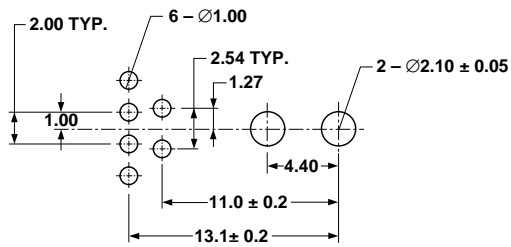
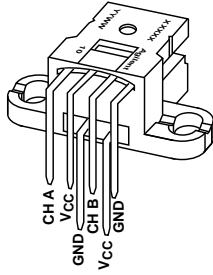

MOUNTING FOOTPRINT

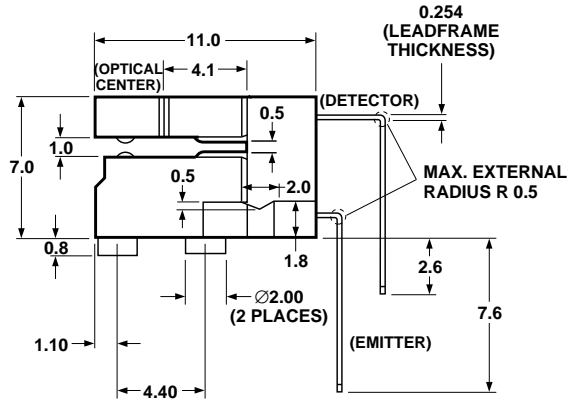
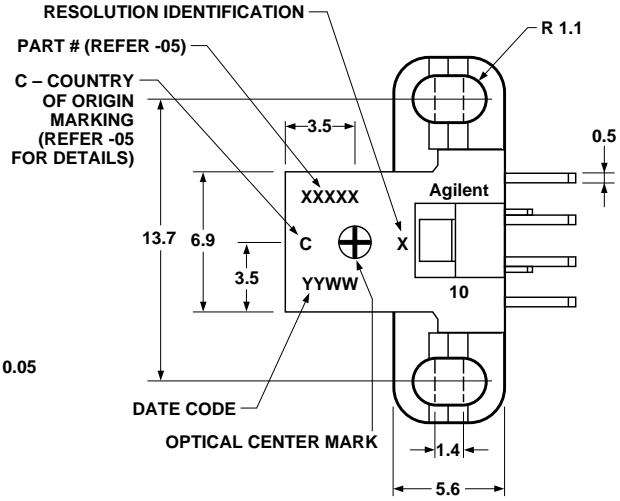
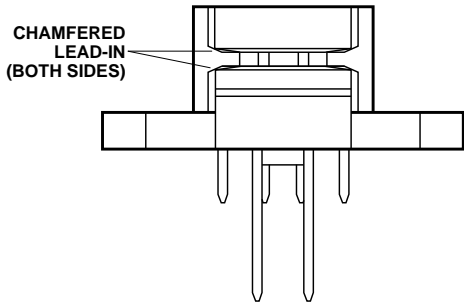

Package Dimensions
AEDS-9620

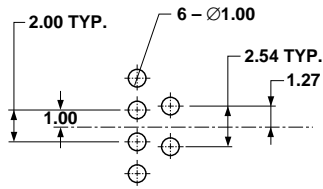
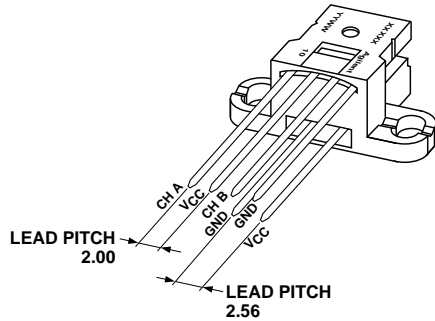

MOUNTING FOOTPRINT

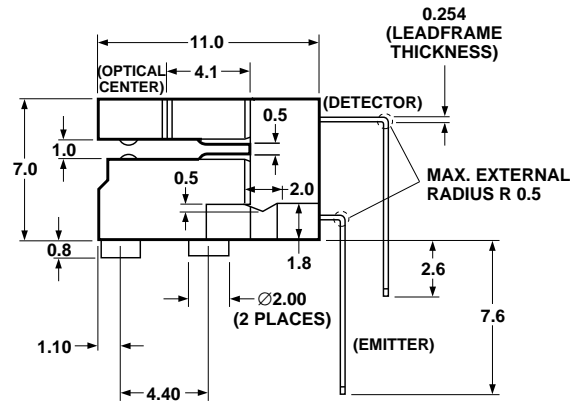
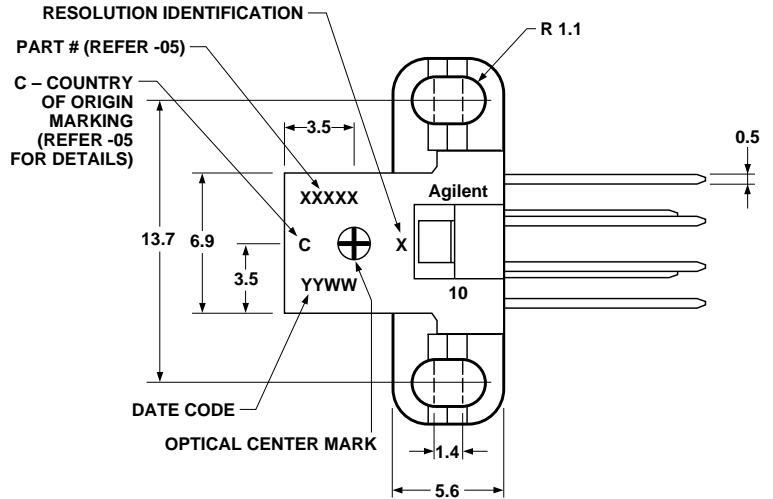
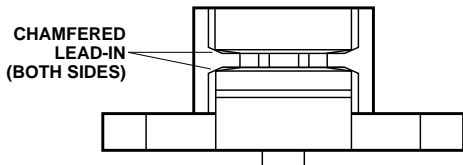

Ordering Information

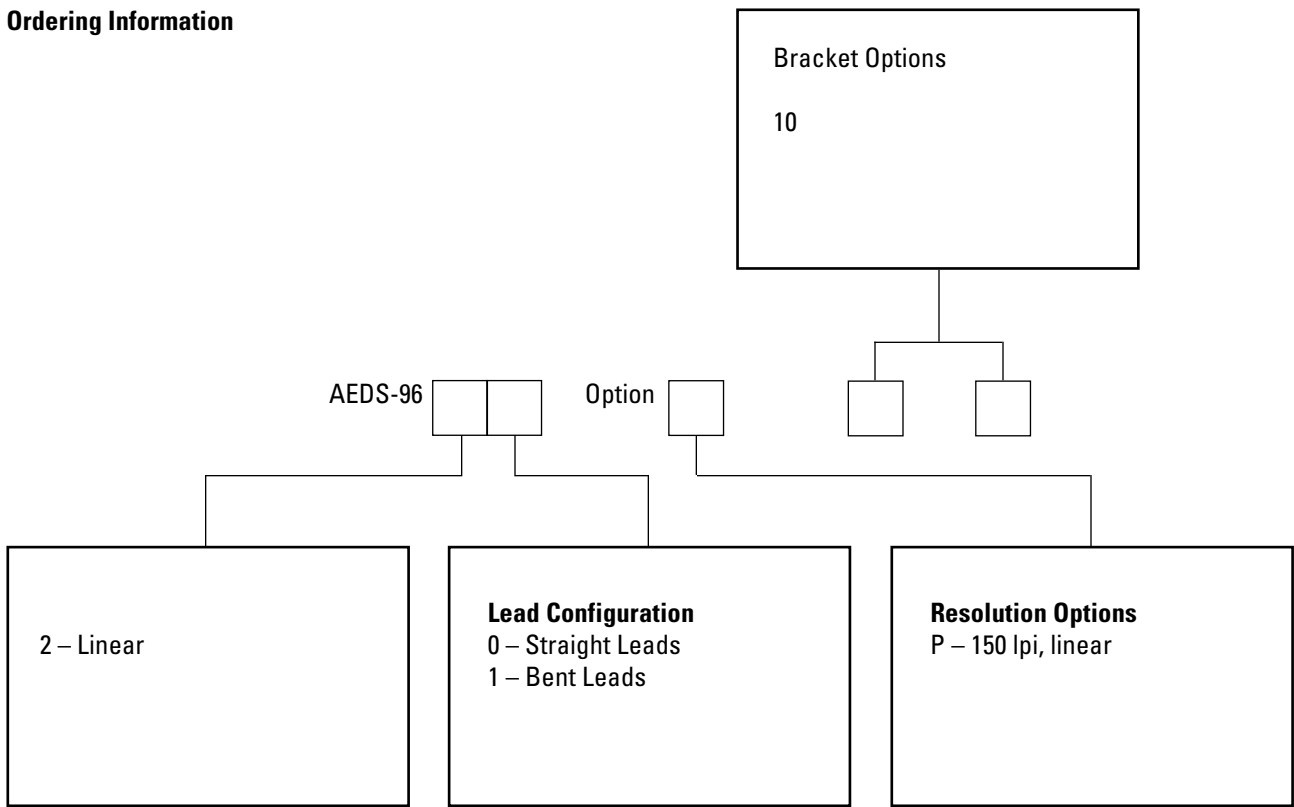

www.agilent.com/semiconductors

For product information and a complete list of distributors, please go to our web site.

For technical assistance call:

Americas/Canada: +1 (800) 235-0312 or (408) 654-8675

Europe: +49 (0) 6441 92460

China: 10800 650 0017

Hong Kong: (+65) 6271 2451

India, Australia, New Zealand: (+65) 6271 2394

Japan: (+81 3) 3335-8152(Domestic/International), or 0120-61-1280(Domestic Only)

Korea: (+65) 6271 2194

Malaysia, Singapore: (+65) 6271 2054

Taiwan: (+65) 6271 2654

Data subject to change.

Copyright © 2002 Agilent Technologies, Inc.

Obsoletes 5988-6185EN

November 25, 2002

5988-8276EN



Agilent Technologies