

1156D-1256D series

POWERSTAT Variable Transformers of the 1156D-1256D Series are available in single and three phase, manually operated and motor-driven assemblies. The 1156D Series operates from 120 volt lines and the 1256D Series from 240 volt lines. The rated output for the 1156D Series is 50 amperes for constant current loads and 55 amperes for constant impedance loads. The 1256D Series is rated at 28 amperes for both constant current and constant impedance loads.

POWERSTAT Variable Transformers of the 1256D Series can be operated at any frequency between 50 and 500 hertz while 1156D Series units operate at 50/60 hertz only. Screens must be removed when operating at frequencies above 60 hertz. Figure A shows the reduction in allowable output current when operated at higher than rated frequency. The regulation curves for types of the 1156D-1256D Series operating at full load current are shown in Figure B. The curves show the voltage drop at any brush setting when full load is applied. For less than full load the voltage drop is proportional to the load. Driving torque, d-c resistance per coil and maximum core and brush loss when operating under no load are given in the chart. 1156D-1256D Series units may be bench or back-of-panel mounted. Manually operated types have standard dials graduated 0-100. The angle of rotation is 318° from zero to maximum output voltage. All units are provided with fuses in the output brush leads. POWERKOTE coils are featured in all 1156D-1256D Series models.

Except for models with chokes, all single units, 2- and 3-gang manually-operated and motor-driven assemblies are available with the terminal board enclosed in a metal terminal box. Knock-outs in the terminal enclosure permit wiring with cable or conduit. If a terminal enclosed unit is desired, include the letter T in the type number following the Series designation. For example: 1256DT-2S.

Open construction models have the letter U suffix in the type number and the same electrical ratings and coil-to-terminal wiring as their corresponding enclosed construction types but have no protective screening.

POWERSTAT Variable Transformers of the 1156D-1256D Series are available in 2-, 3-, 4-, 5-, 6-, 7-, 8- and 9-gang assemblies for manually-operated or motor-driven duty and in 10-, 12-, 14-, 15-, 16-, 18-, 21-, 24- and 27-gang assemblies in motor-driven types only. All can be bench or floor mounted. Single units, 2- and 3-gang manually-operated assemblies can be wall or back-of-panel mounted but additional support should be provided for ganged assemblies.

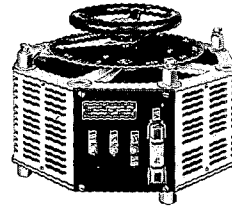

TYPE 1156D

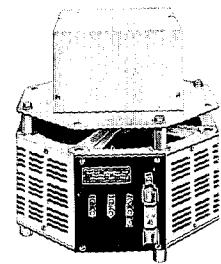

MOTOR-DRIVEN
SCREENED TYPES

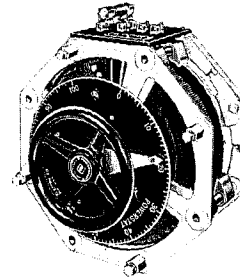

U TYPES

All POWERSTAT Variable Transformers of the 1156D-1256D Series are available as motor-driven assemblies. Motor-driven units have MB prefix in the type number and the identical electrical ratings of their corresponding manually-operated models. Standard speeds for full range travel are: 5, 15, 30 or 60 seconds for single units, 2- and 3-gang assemblies; 15, 30 or 60 seconds for 4-, 5- and 6-gang assemblies; 30 or 60 seconds for 7-, 8-, 9-, 10- and 12-gang assemblies; and 60 seconds for 14-gang and larger. The motor is rated for an input of 120 volts, 50/60 hertz, single phase with a current requirement of approximately 0.4 ampere. When ordering, motor-driven types should be prefixed with the desired speed in seconds. For example: 5MB1156D.

NUMBER OF GANGED UNITS	Approximate Driving Torque		No-Load Loss at 60 Hertz (Watts)	D-C Resistance Per Coil (Ohms)*	
	Oz-In	KpCm		1156D Series	1256D Series
Single	200-250	14.4-18	40	0.11	0.43
2	400-500	28.8-36	80	0.11	0.43
3	600-750	43.2-54	120	0.11	0.43
4	800-1000	57.6-72	160	0.11	0.43
5	1000-1250	72 -90	200	0.11	0.43
6	1200-1500	86.4-108	240	0.11	0.43
7	1400-1750	100.8-126	280	0.11	0.43
8	1600-2000	115.2-144	320	0.11	0.43
9	1800-2250	129.6-162	360	0.11	0.43
10	Motor-driven		400	0.11	0.43
12	Motor-driven		480	0.11	0.43
14	Motor-driven		560	0.11	0.43
15	Motor-driven		600	0.11	0.43
16	Motor-driven		640	0.11	0.43
18	Motor-driven		720	0.11	0.43
21	Motor-driven		840	0.11	0.43
24	Motor-driven		960	0.11	0.43
27	Motor-driven		1080	0.11	0.43

*Measured from start to end of winding.

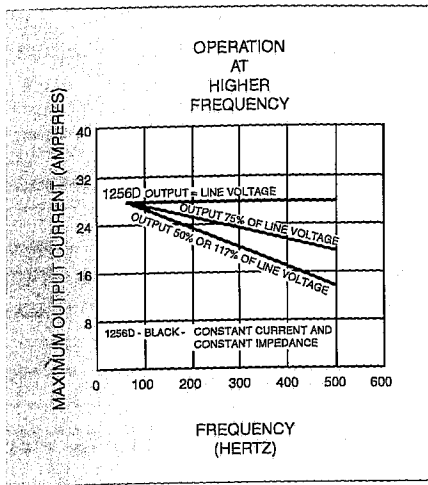
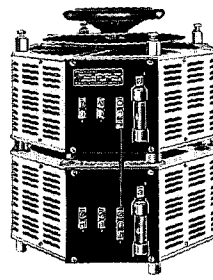
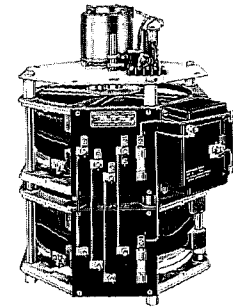

FIGURE A



TYPE
1156D-2S



TYPE
MB1256DU-2P

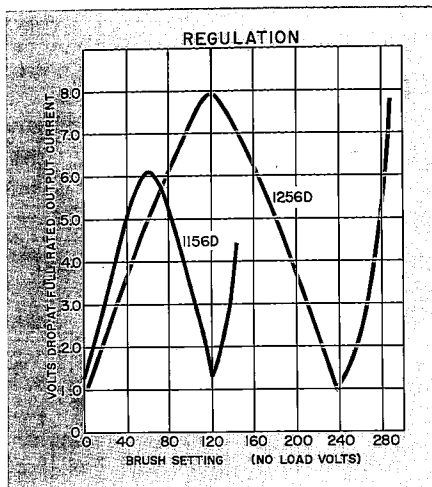
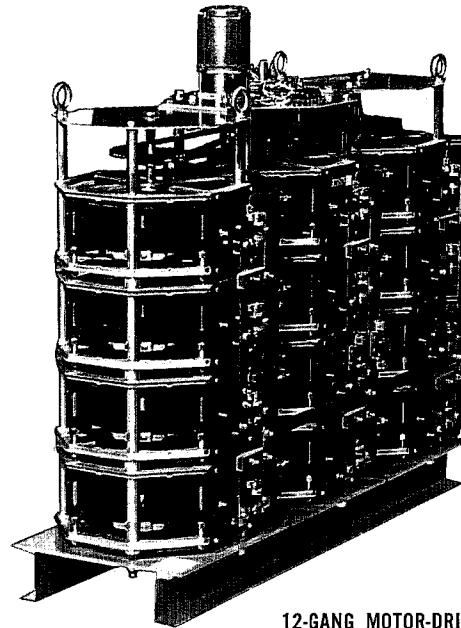

FIGURE B



12-GANG MOTOR-DRIVEN ASSEMBLY

CONNECTIONS AND RATINGS

TYPE		INPUT		OUTPUT				TERMINALS		
		VOLTS	HERTZ	VOLTS	CONSTANT CURRENT LOAD		CONSTANT IMPEDANCE LOAD			
MANUALLY OPERATED	MOTOR DRIVEN				MAX. AMP.	MAX. KVA	MAX. AMP.	MAX. KVA	INPUT	OUTPUT
1156D 1156DT 1156DU	MB1156D MB1156DT MB1156DU	120	50/60	0-120	50	6.0	55	6.6	1-4	1-3
				0-140	50	7.0	—	—	1-2	1-3
1256D 1256DT 1256DU	MB1256D MB1256DT MB1256DU	240	50/60	0-240	28	6.7	28	6.7	1-4	1-3
				0-280	28	7.8	—	—	1-2	1-3
		120	50/60	0-280	28*	3.4†	—	—	1-5	1-3

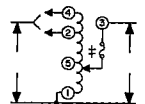

1156D TYPES
DO NOT HAVE
TERMINAL 5.

*Maximum output current in output voltage range up to 150 volts. At higher output voltages, output current must be reduced according to rating curve Figure B on page 4.

†Maximum KVA at maximum output voltage. Maximum KVA at lower output voltages may be calculated from rating curve Figure B on page 4.

‡Fuse supplied: 50 ampere on 1156D types, 30 ampere on 1256D types.

CONNECTIONS AND RATINGS

TYPE		CONNECTION	INPUT		OUTPUT				TERMINALS		
			VOLTS	HERTZ	VOLTS	CONSTANT CURRENT LOAD		CONSTANT IMPEDANCE LOAD			
MANUALLY OPERATED	MOTOR DRIVEN					MAX. AMP.	MAX. KVA	MAX. AMP.	MAX. KVA	INPUT	OUTPUT
1156D-2D 1156DT-2D 1156DU-2D	MB1156D-2D MB1156DT-2D MB1156DU-2D	#1 3-PHASE OPEN DELTA	120	50/60	0-120	50	10.4	55	11.4	4-1-4	3-1-3
					0-140	50	12.1	—	—	2-1-2	3-1-3
1156D-2P 1156DU-2P	MB1156D-2P MB1156DU-2P	#2 1-PHASE PARALLEL	120	50/60	0-120	100	12.0	110	13.2	1-4	1-H ₂
					0-140	100	14.0	—	—	1-2	1-H ₂
1156D-2S 1156DT-2S 1156DU-2S	MB1156D-2S MB1156DT-2S MB1156DU-2S	#1 1-PHASE SERIES	240	50/60	0-240	50	12.0	55	13.2	4-4	3-3
					0-280	50	14.0	—	—	2-2	3-3
1256D-2D 1256DT-2D 1256DU-2D	MB1256D-2D MB1256DT-2D MB1256DU-2D	#1 3-PHASE OPEN DELTA	240	50/60	0-240	28	11.6	28	11.6	4-1-4	3-1-3
					0-280	28	13.6	—	—	2-1-2	3-1-3
1256D-2P 1256DU-2P	MB1256D-2P MB1256DU-2P	#2 1-PHASE PARALLEL	240	50/60	0-240	56	13.4	56	13.4	1-4	1-H ₂
					0-280	56	15.7	—	—	1-2	1-H ₂
1256D-2S 1256DT-2S 1256DU-2S	MB1256D-2S MB1256DT-2S MB1256DU-2S	#1 1-PHASE SERIES	480	50/60	0-480	28	13.4	28	13.4	4-4	3-3
					0-560	28	15.7	—	—	2-2	3-3
1156D-3P 1156DU-3P	MB1156D-3P MB1156DU-3P	#3 1-PHASE PARALLEL	120	50/60	0-120	150	18.0	155	19.8	1-4	1-H ₂
					0-140	150	21.0	—	—	1-2	1-H ₂
1156D-3Y 1156DT-3Y 1156DU-3Y	MB1156D-3Y MB1156DT-3Y MB1156DU-3Y	#4 3-PHASE WYE	240	50/60	0-240	50	20.8	55	22.9	4-4-4	3-3-3
				60	0-280	50	24.2	—	—	2-2-2	3-3-3
1256D-3P 1256DU-3P	MB1256D-3P MB1256DU-3P	#3 1-PHASE PARALLEL	240	50/60	0-240	84	20.2	84	20.2	1-4	1-H ₂
					0-280	84	23.5	—	—	1-2	1-H ₂
1256D-3Y 1256DT-3Y 1256DU-3Y	MB1256D-3Y MB1256DT-3Y MB1256DU-3Y	#4 3-PHASE WYE	480	50/60	0-480	28	23.3	28	23.3	4-4-4	3-3-3
				60	0-560	28	27.2	—	—	2-2-2	3-3-3
			240	60	0-560	28*	11.8†	—	—	5-5-5	3-3-3

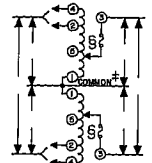

CONNECTION 1

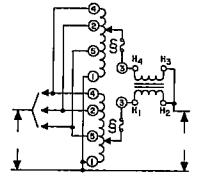

CONNECTION 2

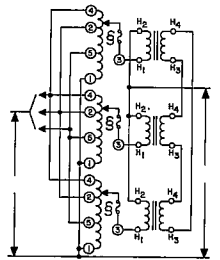

CONNECTION 3

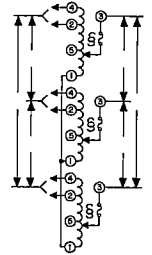

CONNECTION 4

*Maximum output current in output voltage range from 0 to 25 percent above line voltage. At higher output voltages output current must be reduced according to rating curve Figure B on page 4.

†Maximum KVA at maximum output voltage. Maximum KVA at lower output voltages may be calculated from rating curve Figure B on page 4.

‡Common used as third leg in 3-phase open delta or neutral in 3-wire single phase series and 4-wire 3-phase wye connections; not used in 2-wire series or 3-wire wye connections.

§Fuse supplied: 50 ampere on 1156D types, 30 ampere on 1256D types.

NOTE: Choke T5587 is supplied with all parallel connected units in the 1156D-1256D Series.

1156D TYPES
DO NOT HAVE
TERMINAL 5

CONNECTIONS AND RATINGS

TYPE		CONNECTION	INPUT		OUTPUT				TERMINALS			
MANUALLY OPERATED	MOTOR DRIVEN		VOLTS	HERTZ	VOLTS	CONSTANT CURRENT LOAD		CONSTANT IMPEDANCE LOAD		INPUT	JUMPER §§	OUTPUT
						MAX. AMP.	MAX. KVA	MAX. AMP.	MAX. KVA			
1156DU-4D	MB1156DU-4D	#1 3-PHASE OPEN DELTA	120	50/60	0-120	100	20.8	110	22.9	4-1-4	---	H ₂ -1-H ₂
					0-140	100	24.2	---	---	2-1-2	---	H ₂ -1-H ₂
1156DU-4P	MB1156DU-4P	#2 1-PHASE PARALLEL	120	50/60	0-120	200	24.0	220	26.4	P-C	P-4†	S-C
					0-140☆	200	28.0	---	---	P-C	P-2†	S-C
1156DU-4PS	MB1156DU-4PS	#1 1-PHASE SERIES-PARALLEL	240	50/60	0-240	100	24.0	110	26.4	4-4	---	H ₂ -H ₂
					0-280	100	28.0	---	---	2-2	---	H ₂ -H ₂
1256DU-4D	MB1256DU-4D	#1 3-PHASE OPEN DELTA	240	50/60	0-240	56	23.3	56	23.3	4-1-4	---	H ₂ -1-H ₂
					0-280	56	27.2	---	---	2-1-2	---	H ₂ -1-H ₂
1256DU-4P	MB1256DU-4P	#2 1-PHASE PARALLEL	240	50/60	0-280	56§	11.8†	---	---	5-1-5	---	H ₂ -1-H ₂
					0-240	112	26.9	112	26.9	1-4	---	1-H ₂
1256DU-4PS	MB1256DU-4PS	#1 1-PHASE SERIES-PARALLEL	480	50/60	0-480	56	26.9	56	26.9	4-4	---	H ₂ -H ₂
					0-560	56	31.4	---	---	2-2	---	H ₂ -H ₂
1156DU-5P	MB1156DU-5P	#2 1-PHASE PARALLEL	120	50/60	0-120	250	30.0	275	33.0	P-C	P-4†	S-C
					0-140☆	250	35.0	---	---	P-C	P-2†	S-C
1256DU-5P	MB1256DU-5P	#2 1-PHASE PARALLEL	240	50/60	0-240	140	33.6	140	33.6	1-4	---	1-H ₂
					0-280	140	39.2	---	---	1-2	---	1-H ₂
1156DU-6D	MB1156DU-6D	#3 3-PHASE OPEN DELTA	120	50/60	0-120	150	31.2	165	34.3	4-1-4	---	H ₂ -1-H ₂
					0-140	150	36.4	---	---	2-1-2	---	H ₂ -1-H ₂
1156DU-6P	MB1156DU-6P	#2 1-PHASE PARALLEL	120	50/60	0-120	300	36.0	330	39.6	P-C	P-4†	S-C
					0-140☆	300	42.0	---	---	P-C	P-2†	S-C
1156DU-6PS	MB1156DU-6PS	#4 1-PHASE SERIES-PARALLEL	240	50/60	0-240	150	36.0	165	39.6	4-4	---	H ₂ -H ₂
					0-280	150	42.0	---	---	2-2	---	H ₂ -H ₂
1156DU-6Y	MB1156DU-6Y	#3 3-PHASE WYE	240	50/60	0-240	100	41.6	110	45.7	4-4-4	---	H ₂ -H ₂ -H ₂
					60	100	48.5	---	---	2-2-2	---	H ₂ -H ₂ -H ₂
1256DU-6D	MB1256DU-6D	#4 3-PHASE OPEN DELTA	240	50/60	0-240	84	34.9	84	34.9	4-1-4	---	H ₂ -1-H ₂
					0-280	84	40.7	---	---	2-1-2	---	H ₂ -1-H ₂
1256DU-6P	MB1256DU-6P	#2 1-PHASE PARALLEL	120	50/60	0-280	84§	17.6†	---	---	5-1-5	---	H ₂ -1-H ₂
					0-240	168	40.3	168	40.3	P-C	P-4†	S-C
1256DU-6PS	MB1256DU-6PS	#4 1-PHASE SERIES-PARALLEL	480	50/60	0-480	84	40.3	84	40.3	4-4	---	H ₂ -H ₂
					0-560	84	47.0	---	---	2-2	---	H ₂ -H ₂
1256DU-6Y	MB1256DU-6Y	#3 3-PHASE WYE	480	50/60	0-480	56	46.6	56	46.6	4-4-4	---	H ₂ -H ₂ -H ₂
					60	56	54.3	---	---	2-2-2	---	H ₂ -H ₂ -H ₂
1156DU-7P	MB1156DU-7P	#2 1-PHASE PARALLEL	120	50/60	0-120	350	42.0	385	46.2	P-C	P-4††	S-C
					0-140☆	350	49.0	---	---	P-C	P-2††	S-C
1256DU-7P	MB1256DU-7P	#2 1-PHASE PARALLEL	240	50/60	0-240	196	47.0	196	47.0	P-C	P-4†	S-C
					0-280☆	196	54.9	---	---	P-C	P-2†	S-C
1156DU-8D	MB1156DU-8D	#4 3-PHASE OPEN DELTA	120	50/60	0-120	200	41.6	220	45.7	P ₁ -P ₂ -P ₃	P ₁ -4†, P ₃ -4†	S ₁ -S ₂ -S ₃
					0-140☆	200	48.5	---	---	P ₁ -P ₂ -P ₃	P ₁ -2†, P ₃ -2†	S ₁ -S ₂ -S ₃
1156DU-8P	MB1156DU-8P	#2 1-PHASE PARALLEL	120	50/60	0-120	400	48.0	440	52.8	P-C	P-4††	S-C
					0-140☆	400	56.0	---	---	P-C	P-2††	S-C
1156DU-8PS	MB1156DU-8PS	#4 1-PHASE SERIES-PARALLEL	240	50/60	0-240	200	48.0	220	52.8	P ₁ -P ₂	P ₁ -4†, P ₂ -4†	S ₁ -S ₂
					0-280☆	200	56.0	---	---	P ₁ -P ₂	P ₁ -2†, P ₂ -2†	S ₁ -S ₂
1256DU-8D	MB1256DU-8D	#4 3-PHASE OPEN DELTA	240	50/60	0-240	112	46.6	112	46.6	4-1-4	---	H ₂ -1-H ₂
					0-280	112	54.3	---	---	2-1-2	---	H ₂ -1-H ₂
1256DU-8P	MB1256DU-8P	#2 1-PHASE PARALLEL	120	50/60	0-240	224	53.8	224	53.8	P-C	P-4†	S-C
					0-280☆	224	62.7	---	---	P-C	P-2†	S-C
1256DU-8PS	MB1256DU-8PS	#4 1-PHASE SERIES-PARALLEL	480	50/60	0-480	112	53.8	112	53.8	4-4	---	H ₂ -H ₂
					0-560	112	62.7	---	---	2-2	---	H ₂ -H ₂
1156DU-9P	MB1156DU-9P	#2 1-PHASE PARALLEL	120	50/60	0-120	450	54.0	495	59.4	P-C	P-4††	S-C
					0-140☆	450	63.0	---	---	P-C	P-2††	S-C
1156DU-9Y	MB1156DU-9Y	#5 3-PHASE WYE	240	50/60	0-240	150	62.4	165	68.6	4-4-4	---	H ₂ -H ₂ -H ₂
					60	150	72.7	---	---	2-2-2	---	H ₂ -H ₂ -H ₂
1256DU-9P	MB1256DU-9P	#2 1-PHASE PARALLEL	240	50/60	0-240	252	60.5	252	60.5	P-C	P-4††	S-C
					0-280☆	252	70.6	---	---	P-C	P-2††	S-C
1256DU-9P	MB1256DU-9P	#2 1-PHASE PARALLEL	120	50/60	0-280	252§	30.6†	---	---	P-C	P-5††	S-C
					0-480	84	69.8	84	69.8	4-4-4	---	H ₂ -H ₂ -H ₂
1256DU-9Y	MB1256DU-9Y	#5 3-PHASE WYE	480	50/60	0-480	84	81.5	---	---	2-2-2	---	H ₂ -H ₂ -H ₂
					60	84	81.5	---	---	2-2-2	---	H ₂ -H ₂ -H ₂

§ Maximum output current in output voltage range from 0 to 25 percent above line voltage. At higher output voltages output current must be reduced according to rating curve Figure B on page 4.

§§ Units are supplied with all required jumpers. Those indicated in the chart are wired permanently to the primary lugs on the terminal panel but are shifted between the #2, #4 and #5 terminals as required.

† Maximum KVA at maximum output voltage. Maximum KVA at lower output voltages may be calculated from rating curve Figure B on page 4.

†† Common used as third leg in 3-phase open delta or neutral in 3-wire single phase series and 4-wire 3-phase wye connections; not used in 2-wire series or 3-wire wye connections.

‡ Terminal designations on P and PS types with separate terminal boards.

‡‡ Three jumpers (see also §§ footnote above).

* Fuse supplied: 50 ampere on 1156D types, 30 ampere on 1256D types.

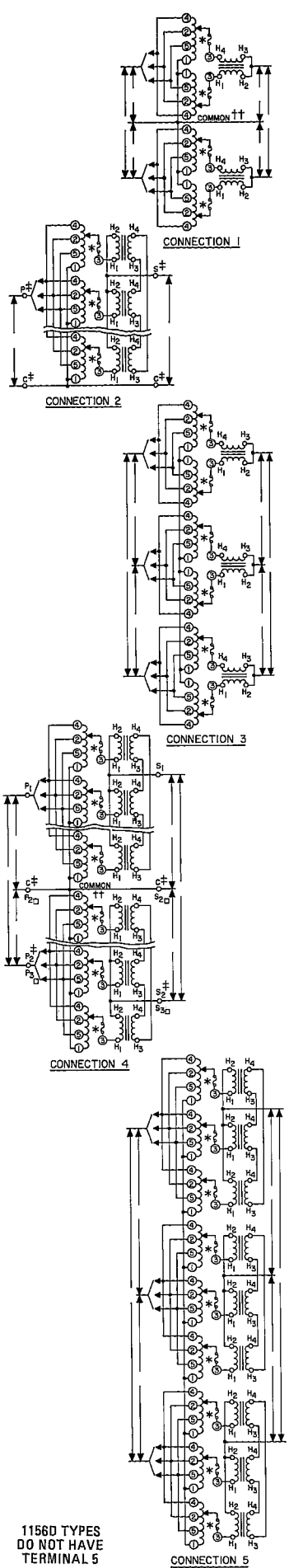

1156D TYPES DO NOT HAVE TERMINAL 5

† Two jumpers (see also §§ footnote above).
‡ Terminal designations on 1156D-8D types.

RATINGS OPEN DELTA AND SERIES-PARALLEL TYPES

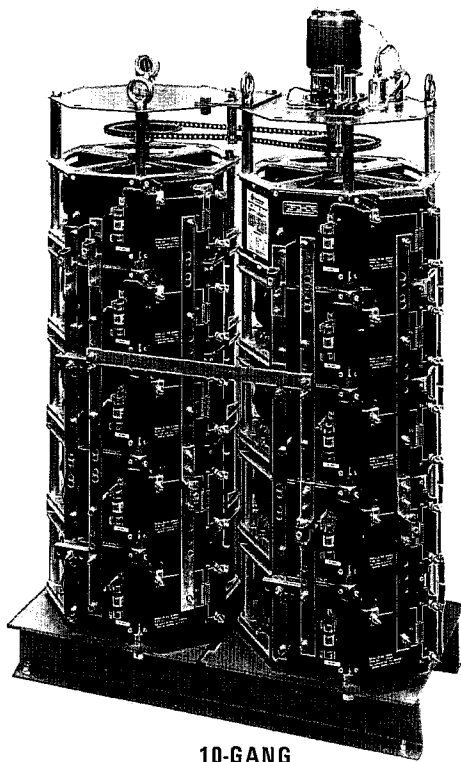

**10-GANG
MOTOR-DRIVEN
ASSEMBLY**

TYPE	CONNECTION	INPUT		OUTPUT				
		VOLTS	HERTZ	VOLTS	CONSTANT CURRENT LOAD		CONSTANT IMPEDANCE LOAD	
					MAX. AMP.	MAX. KVA	MAX. AMP.	MAX. KVA
MB1156DU-10D	3-PHASE OPEN DELTA	120	50/60	0-120	250	51.9	275	57.2
				0-140□	250	60.6	—	—
MB1156DU-10PS	1-PHASE SERIES-PARALLEL	240	50/60	0-240	250	60.0	275	66.0
				0-280□	250	70.0	—	—
MB1256DU-10D	3-PHASE OPEN DELTA	240	50/60	0-240	140	58.2	140	58.2
				0-280□	140	67.9	—	—
		120	50/60	0-280	140*	29.4†	—	—
MB1256DU-10PS	1-PHASE SERIES-PARALLEL	480	50/60	0-480	140	67.2	140	67.2
				0-560□	140	78.4	—	—
		240	50/60	0-560	140*	33.9†	—	—
MB1156DU-12D	3-PHASE OPEN DELTA	120	50/60	0-120	300	62.4	330	68.6
				0-140□	300	72.7	—	—
MB1156DU-12PS	1-PHASE SERIES-PARALLEL	240	50/60	0-240	300	72.0	330	79.2
				0-280□	300	84.0	—	—
MB1256DU-12D	3-PHASE OPEN DELTA	240	50/60	0-240	168	69.8	168	69.8
				0-280□	168	81.5	—	—
		120	50/60	0-280	168*	35.3†	—	—
MB1256DU-12PS	1-PHASE SERIES-PARALLEL	480	50/60	0-480	168	80.6	168	80.6
				0-560□	168	94.1	—	—
		240	50/60	0-560	168*	40.7†	—	—
MB1156DU-14D	3-PHASE OPEN DELTA	120	50/60	0-120	350	72.7	385	80.0
				0-140□	350	84.9	—	—
MB1156DU-14PS	1-PHASE SERIES-PARALLEL	240	50/60	0-240	350	84.0	385	92.4
				0-280□	350	98.0	—	—
MB1256DU-14D	3-PHASE OPEN DELTA	240	50/60	0-240	196	81.5	196	81.5
				0-280□	196	95.1	—	—
		120	50/60	0-280	196*	41.2†	—	—
MB1256DU-14PS	1-PHASE SERIES-PARALLEL	480	50/60	0-480	196	94.1	196	94.1
				0-560□	196	110	—	—
		240	50/60	0-560	196*	47.5†	—	—
MB1156DU-16D	3-PHASE OPEN DELTA	120	50/60	0-120	400	83.1	440	91.5
				0-140□	400	97.0	—	—
MB1156DU-16PS	1-PHASE SERIES-PARALLEL	240	50/60	0-240	400	96.0	440	106
				0-280□	400	112	—	—
MB1256DU-16D	3-PHASE OPEN DELTA	240	50/60	0-240	224	93.1	224	93.1
				0-280□	224	109	—	—
		120	50/60	0-280	224*	47.0†	—	—
MB1256DU-16PS	1-PHASE SERIES-PARALLEL	480	50/60	0-480	224	108	224	108
				0-560□	224	125	—	—
		240	50/60	0-560	224*	54.3†	—	—
MB1156DU-18D	3-PHASE OPEN DELTA	120	50/60	0-120	450	93.5	495	103
				0-140□	450	109	—	—
MB1156DU-18PS	1-PHASE SERIES-PARALLEL	240	50/60	0-240	450	108	495	119
				0-280□	450	126	—	—
MB1256DU-18D	3-PHASE OPEN DELTA	240	50/60	0-240	252	105	252	105
				0-280□	252	122	—	—
		120	50/60	0-280	252*	52.9†	—	—
MB1256DU-18PS	1-PHASE SERIES-PARALLEL	480	50/60	0-480	252	121	252	121
				0-560□	252	141	—	—
		240	50/60	0-560	252*	61.1†	—	—

*Maximum output current in output voltage range from 0 to 25 percent above line voltage. At higher output voltages output current must be reduced according to rating curve Figure B on page 4.

†Maximum KVA at maximum output voltage. Maximum KVA at lower output voltages may be calculated from rating curve Figure B on page 4.

□ Unit wired this way when shipped.

RATINGS WYE TYPES

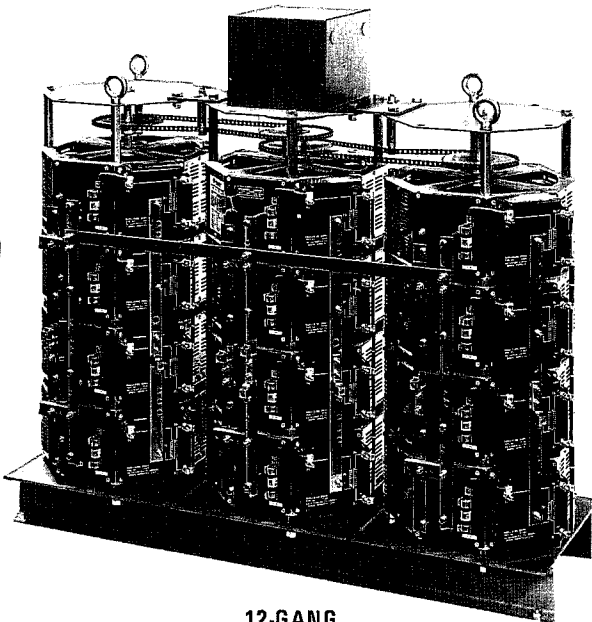

**12-GANG
MOTOR-DRIVEN
ASSEMBLY**

TYPE	CONNECTION	INPUT		OUTPUT				
		VOLTS	HERTZ	VOLTS	CONSTANT CURRENT LOAD		CONSTANT IMPEDANCE LOAD	
					MAX. AMP.	MAX. KVA	MAX. AMP.	MAX. KVA
MB1156DU-12Y	3-PHASE WYE	240	50/60	0-240	200	83.1	220	91.5
			60	0-280☆	200	97.0	—	—
MB1256DU-12Y	3-PHASE WYE	480	50/60	0-480	112	93.1	112	93.1
			60	0-560☆	112	109	—	—
		240	60	0-560	112*	47.0†	—	—
MB1156DU-15Y	3-PHASE WYE	240	50/60	0-240	250	104	275	114
			60	0-280☆	250	121	—	—
MB1256DU-15Y	3-PHASE WYE	480	50/60	0-480	140	116	140	116
			60	0-560☆	140	136	—	—
		240	60	0-560	140*	58.8†	—	—
MB1156DU-18Y	3-PHASE WYE	240	50/60	0-240	300	125	330	137
			60	0-280☆	300	145	—	—
MB1256DU-18Y	3-PHASE WYE	480	50/60	0-480	168	140	168	140
			60	0-560☆	168	163	—	—
		240	60	0-560	168*	70.6†	—	—
MB1156DU-21Y	3-PHASE WYE	240	50/60	0-240	350	145	385	160
			60	0-280☆	350	170	—	—
MB1256DU-21Y	3-PHASE WYE	480	50/60	0-480	196	163	196	163
			60	0-560☆	196	190	—	—
		240	60	0-560	196*	82.3†	—	—
MB1156DU-24Y	3-PHASE WYE	240	50/60	0-240	400	166	440	183
			60	0-280☆	400	194	—	—
MB1256DU-24Y	3-PHASE WYE	480	50/60	0-480	224	186	224	186
			60	0-560☆	224	217	—	—
		240	60	0-560	224*	94.1†	—	—
MB1156DU-27Y	3-PHASE WYE	240	50/60	0-240	450	187	495	206
			60	0-280☆	450	218	—	—
MB1256DU-27Y	3-PHASE WYE	480	50/60	0-480	252	210	252	210
			60	0-560☆	252	244	—	—
		240	60	0-560	252*	106†	—	—

*Maximum output current in output voltage range up to 300 volts. At higher output voltages, output current must be reduced according to rating curve Figure B on page 4.

†Maximum KVA at maximum output voltage. Maximum KVA at lower output voltages may be calculated from rating curve Figure B on page 4.

☆ Unit wired this way when shipped.

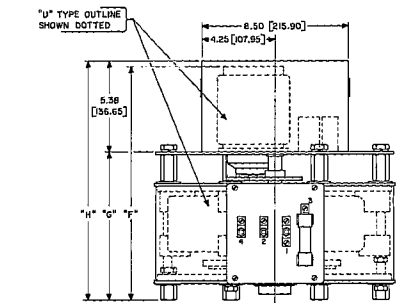
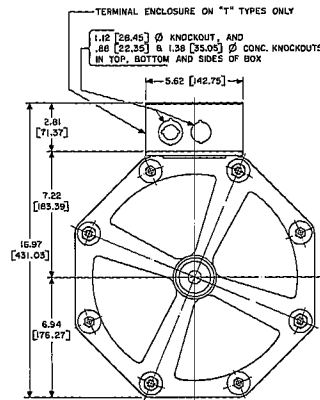
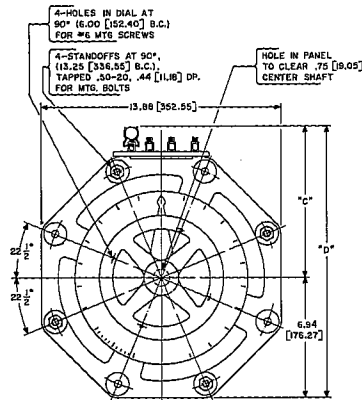
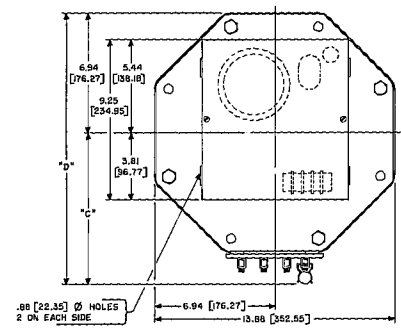
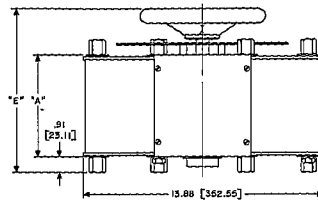
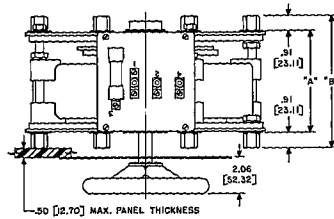

PANEL MOUNTED

BENCH OR WALL MOUNTED

MOTOR DRIVEN

	TYPE	"A"	"B"	"C"	"D"	"E"	"F"	"G"	"H"
1156D-1256D SERIES	SINGLE UNIT	5.68 [149.35]	7.69 [195.32]			9.47 [240.54]	15.44 [392.18]	8.50 [215.90]	15.76 [400.30]
	2-GANG	12.50 [317.50]	14.31 [363.47]	8.72 [221.49]	15.66 [397.76]	16.09 [408.68]	22.06 [560.32]	15.12 [384.05]	22.38 [568.45]
	3-GANG	19.12 [485.65]	20.94 [531.87]			22.72 [577.09]	28.69 [728.73]	21.75 [552.45]	29.00 [736.60]

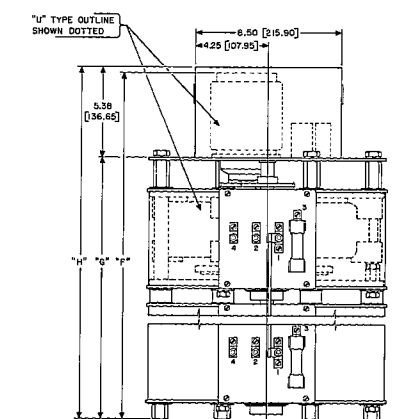
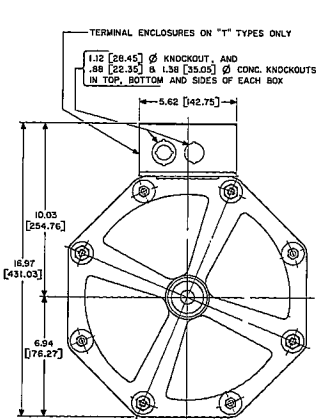
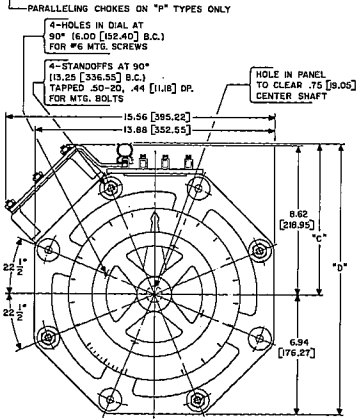
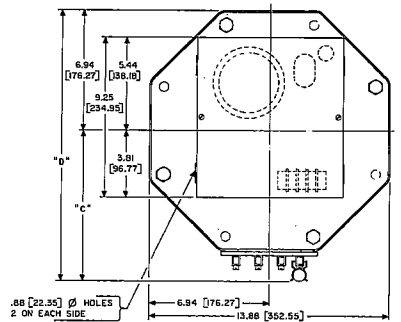
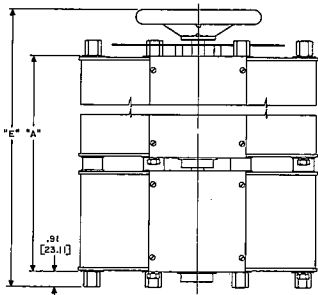
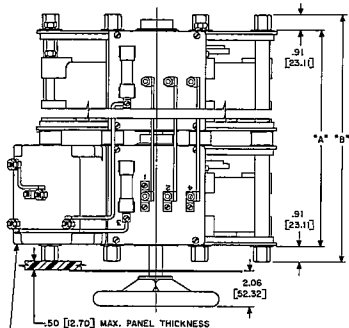

PANEL MOUNTED

BENCH OR WALL MOUNTED

MOTOR DRIVEN

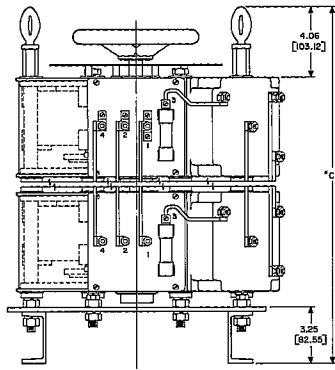
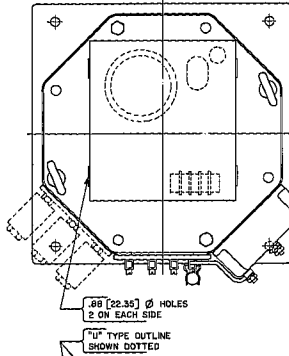
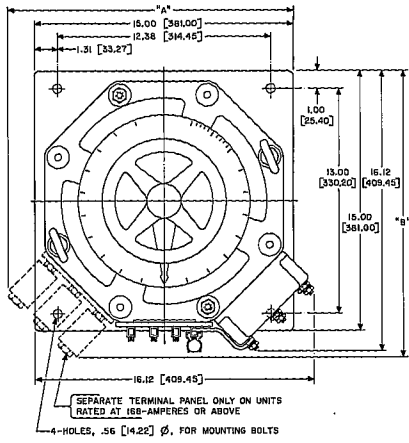

4-GANG TO 9-GANG MANUAL

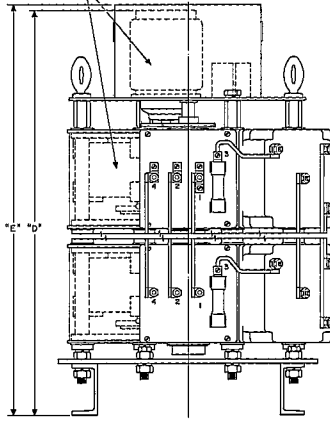

4-GANG TO 9-GANG MOTOR DRIVEN

TYPE	"A"		"B"		"C"	"D"	"E"
	1156D	1256D	1156D	1256D			
4D, 4PS	—	—	—	—	34.00 [863.60]	38.65 [981.71]	39.00 [990.60]
4P	16.75 [425.45]	—	15.62 [396.75]	—	34.00 [863.60]	38.65 [981.71]	39.00 [990.60]
5P	16.75 [425.45]	—	15.62 [396.75]	—	40.62 [1031.75]	45.31 [1159.87]	45.53 [1159.00]
6D, 6PS	—	—	—	—	47.25 [1200.15]	51.94 [1319.28]	52.25 [1327.40]
6Y	17.31 [439.69]	16.75 [425.45]	16.19 [411.23]	15.62 [396.75]	47.25 [1200.15]	51.94 [1319.28]	52.25 [1327.40]
7P	17.31 [439.69]	16.75 [425.45]	16.19 [411.23]	15.62 [396.75]	53.88 [1368.55]	58.56 [1487.42]	58.88 [1495.55]
8D, 8PS	16.75 [425.45]	—	15.62 [396.75]	—	60.50 [1536.70]	65.19 [1655.83]	65.50 [1663.70]
8P	17.75 [450.85]	16.75 [425.45]	16.62 [422.15]	15.62 [396.75]	60.50 [1536.70]	65.19 [1655.83]	65.50 [1663.70]
9P	17.75 [450.85]	17.31 [439.69]	16.62 [422.15]	15.19 [411.23]	67.12 [1704.85]	71.81 [1823.87]	72.13 [1832.10]
9Y	—	—	—	—	67.12 [1704.85]	71.81 [1823.87]	72.13 [1832.10]

NOTE: Interconnections may be by bus bars instead of wire harnesses as illustrated.

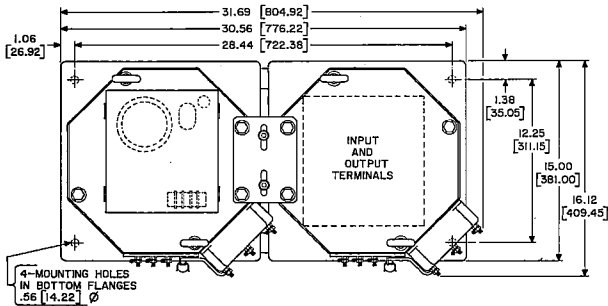

	10D, 10PS	12D, 12PS	14D, 14PS	16D, 16PS	18D, 18PS
"A"	49.44 [1255.78]	56.06 [1423.92]	62.69 [1592.33]	69.31 [1760.47]	75.94 [1928.88]
"B"	49.76 [1263.90]	56.38 [1432.05]	63.00 [1600.20]	69.63 [1766.60]	76.25 [1937.00]

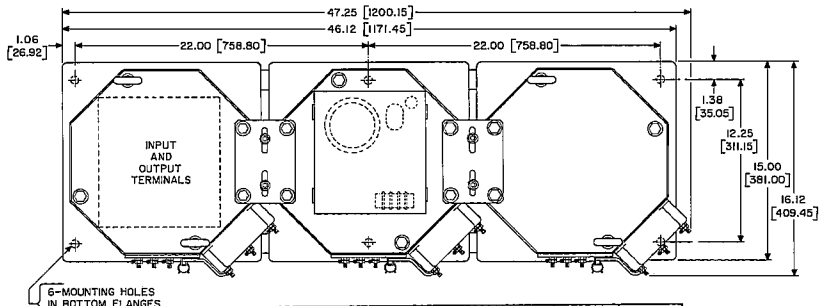

	12Y	15Y	18Y	21Y	24Y	27Y
"A"	42.82 [1087.63]	49.44 [1255.78]	56.06 [1423.92]	62.69 [1592.33]	69.31 [1760.47]	75.94 [1928.88]
"B"	43.13 [1095.50]	49.76 [1263.90]	56.38 [1432.05]	63.00 [1600.20]	69.63 [1766.60]	76.25 [1937.00]

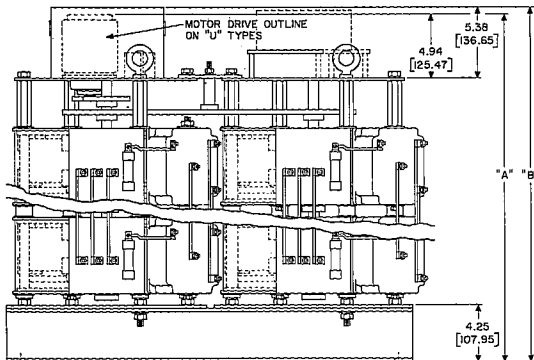

10- TO 18-GANG OPEN DELTA AND SERIES-PARALLEL TYPES

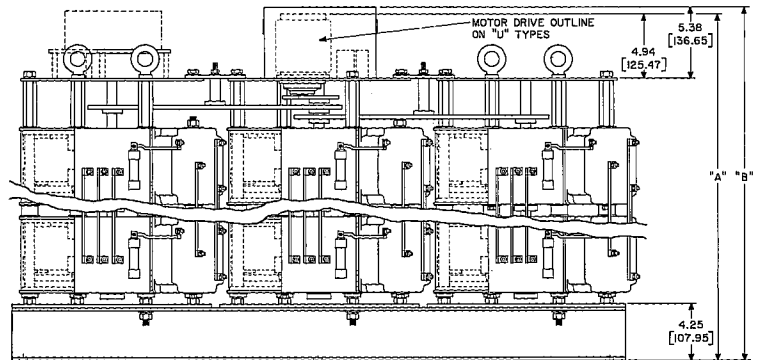

12- TO 27-GANG WYE TYPES