

30 W Power Resistor Thick Film Technology



FEATURES

- 30 W at 25 °C case temperature heatsink mounted
- Direct mounting ceramic on heatsink
- Broad resistance range: 0.010 Ω to 550 kΩ
- Non inductive
- TO-220 package: Compact and easy to mount
- Material categorization: For definitions of compliance please see www.vishay.com/doc?99912

RoHS
COMPLIANT

LTO series are the extension of RTO types. We used the direct ceramic mounting design (no metal tab) of our RCH power resistors applied to semiconductor packages.

DIMENSIONS in millimeters

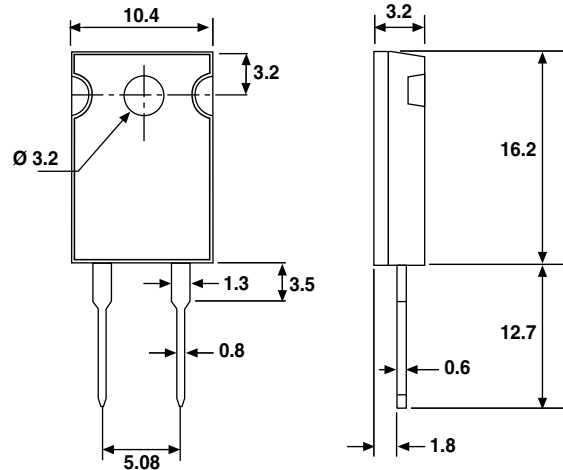

Note

- Tolerances unless stated: ± 0.3 mm

STANDARD ELECTRICAL SPECIFICATIONS

MODEL	SIZE	RESISTANCE RANGE Ω	RATED POWER $P_{25\text{ °C}}$ W	LIMITING ELEMENT VOLTAGE U_L V	TOLERANCE ± %	TEMPERATURE COEFFICIENT ± ppm/°C	CRITICAL RESISTANCE Ω
LTO 30	TO-220	0.010 to 550K	30	500	1, 2, 5, 10	150, 250, 700, 900	8.33K

MECHANICAL SPECIFICATIONS

Mechanical Protection	Molded
Resistive Element	Thick film
Substrate	Alumina
Connections	Tinned copper
Weight	2 g max.
Mounting Torque	1 Nm

ENVIRONMENTAL SPECIFICATIONS

Temperature Range	- 55 °C to + 155 °C
Climatic Category	55/155/56

ENVIRONMENTAL SPECIFICATIONS

Flammability	IEC 60695-11-5 2 applications 30 s separated by 60 s
--------------	--

TECHNICAL SPECIFICATIONS

Dissipation and Associated	Onto a heatsink
Power Rating and Thermal Resistance of the Component	30 W at + 25 °C (case temp.) $R_{TH(j-c)}$: 4.2 °C/W Free air: 2.25 W at + 25 °C
Temperature Coefficient Standard	See Performance table ± 150 ppm/°C
Dielectric Strength MIL STD 202	1500 V_{RMS} - 1 min 10 mA max.



TECHNICAL SPECIFICATIONS	
Insulation Resistance	$\geq 10^4 \text{ M}\Omega$
Inductance	$\leq 0.1 \text{ }\mu\text{H}$

PERFORMANCE		
TESTS	CONDITIONS	REQUIREMENTS
Momentary Overload	EN 60115-1 1.5 Pr/5 s $U_S < 1.5 U_L$	$\pm (0.5 \% + 0.005 \Omega)$
Rapid Temperature Change	EN 60115-1 IEC 60068-2-14 Test Na 5 cycles - 55 °C to + 155 °C	$\pm (0.5 \% + 0.005 \Omega)$
Load Life	EN 60115-1 1000 h Pr at + 25 °C	$\pm (1 \% + 0.005 \Omega)$
Humidity (Steady State)	MIL-STD-202 method 103 B cond. D	$\pm (0.5 \% + 0.005 \Omega)$
Vibration	MIL-STD-202 method 204 cond. D	$\pm (0.2 \% + 0.005 \Omega)$
Terminal Strength	MIL-STD-202 method 211 cond. A1	$\pm (0.2 \% + 0.005 \Omega)$
Shock	100G, MIL-STD-202 method 213 cond. I	$\pm (0.5 \% + 0.005 \Omega)$

SPECIAL FEATURES				
Resistance Values	≥ 0.010	≥ 0.015	≥ 0.1	≥ 0.5
Tolerances	$\pm 1 \% \text{ at } \pm 10 \%$			
Typical Temperature Coefficient (- 55 ° to + 155 °C)	$\pm 900 \text{ ppm}/^\circ\text{C}$	$\pm 700 \text{ ppm}/^\circ\text{C}$	$\pm 250 \text{ ppm}/^\circ\text{C}$	$\pm 150 \text{ ppm}/^\circ\text{C}$

CHOICE OF THE HEATSINK

The user must choose according to the working conditions of the component (power, room temperature).

Maximum working temperature must not exceed 155 °C. The dissipated power is simply calculated by the following ratio:

$$P = \frac{\Delta T}{R_{TH(j-c)} + R_{TH(c-h)} + R_{TH(h-a)}} \quad (1)$$

P: Expressed in W

ΔT : Difference between maximum working temperature and room temperature

$R_{TH(j-c)}$: Thermal resistance value measured between resistive layer and outer side of the resistor. It is the thermal resistance of the component.

$R_{TH(c-h)}$: Thermal resistance value measured between outer side of the resistor and upper side of the heatsink. This is the thermal resistance of the interface (grease, thermal pad), and the quality of the fastening device.

$R_{TH(h-a)}$: Thermal resistance of the heatsink.

Example:

$R_{TH(c-a)}$ for LTO 30 power rating 10 W at ambient temperature + 25 °C

Thermal resistance $R_{TH(j-c)}$: 4.2 °C/W

Considering equation (1) we have:

$$\Delta T = 150 \text{ }^\circ\text{C} - 25 \text{ }^\circ\text{C} = 125 \text{ }^\circ\text{C}$$

$$R_{TH(j-c)} + R_{TH(c-h)} + R_{TH(h-a)} = \frac{\Delta T}{P} = \frac{125}{10} = 12.5 \text{ }^\circ\text{C}/\text{W}$$

$$R_{TH(c-h)} + R_{TH(h-a)} = 12.5 \text{ }^\circ\text{C}/\text{W} - 4.2 \text{ }^\circ\text{C}/\text{W} = 8.3 \text{ }^\circ\text{C}/\text{W}$$

with a thermal grease $R_{TH(c-h)} = 1 \text{ }^\circ\text{C}/\text{W}$, we need a heatsink with $R_{TH(h-a)} = 7.3 \text{ }^\circ\text{C}/\text{W}$.



OVERLOADS

In any case the applied voltage must be lower than the maximum overload voltage of 750 V.

The values indicated on the graph below are applicable to resistors in air or mounted onto a heatsink.

ENERGY CURVE

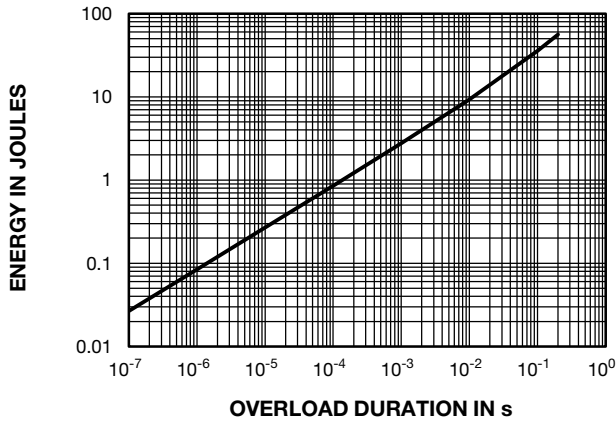

POWER CURVE

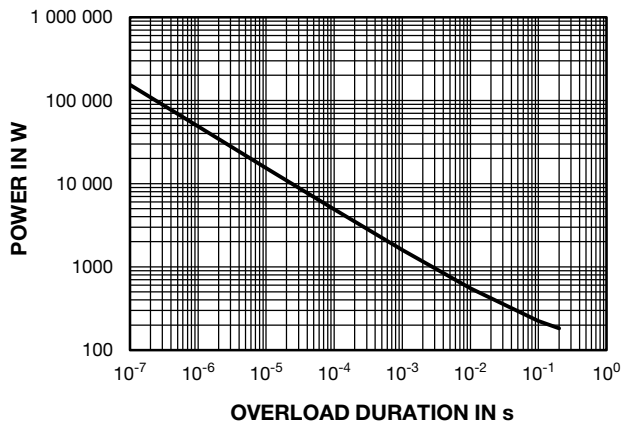

POWER RATING

The temperature of the case should be maintained within the limits specified.

To improve the thermal conductivity, surfaces in contact should be coated with a silicone grease and the torque applied on the screw for tightening should be around 1 Nm.

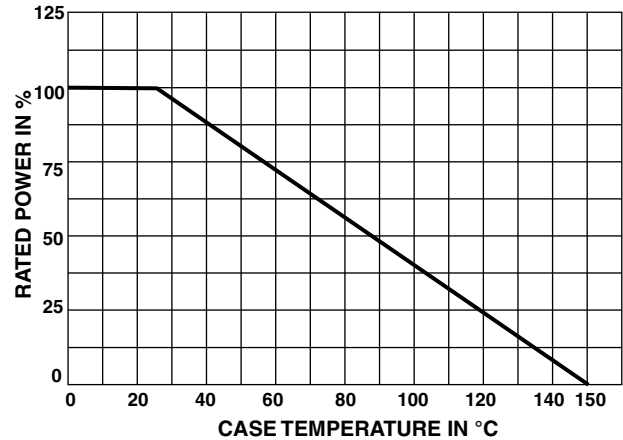

PACKAGING

Tube of 50 units

MARKING

Model, style, resistance value (in Ω), tolerance (in %), manufacturing date, Vishay Sfernice trademark.



ORDERING INFORMATION							
LTO	30	F	2.7 kΩ	± 1 %	xxx	TU50	e3
MODEL	STYLE	CONNECTIONS	RESISTANCE VALUE	TOLERANCE	CUSTOM DESIGN	PACKAGING	LEAD (Pb)-FREE
				± 1 % ± 2 % ± 5 % ± 10 %	Optional on request: Special TCR, shape etc.		

GLOBAL PART NUMBER INFORMATION															
L	T	O	0	3	0	F	2	7	0	0	0	J	T	E	3
GLOBAL MODEL	SIZE	LEADS	OHMIC VALUE				TOLERANCE	PACKAGING	LEAD (Pb)-FREE						
LTO	030	F = Radial leads	<p>The first four digits are significant figures and the last digit specifies the number of zeros to follow. R designates decimal point.</p> <p>48R70 = 48.7 Ω 48701 = 48 700 Ω 10002 = 100 000 Ω R0100 = 0.01 Ω R4700 = 0.47 Ω 27000 = 2700 Ω = 2.7 kΩ</p>				<p>F = 1 % G = 2 % J = 5 % K = 10 %</p>	<p>T = Tube Tube 50 pieces</p>	E3 = Pure tin						



Disclaimer

ALL PRODUCT, PRODUCT SPECIFICATIONS AND DATA ARE SUBJECT TO CHANGE WITHOUT NOTICE TO IMPROVE RELIABILITY, FUNCTION OR DESIGN OR OTHERWISE.

Vishay Intertechnology, Inc., its affiliates, agents, and employees, and all persons acting on its or their behalf (collectively, "Vishay"), disclaim any and all liability for any errors, inaccuracies or incompleteness contained in any datasheet or in any other disclosure relating to any product.

Vishay makes no warranty, representation or guarantee regarding the suitability of the products for any particular purpose or the continuing production of any product. To the maximum extent permitted by applicable law, Vishay disclaims (i) any and all liability arising out of the application or use of any product, (ii) any and all liability, including without limitation special, consequential or incidental damages, and (iii) any and all implied warranties, including warranties of fitness for particular purpose, non-infringement and merchantability.

Statements regarding the suitability of products for certain types of applications are based on Vishay's knowledge of typical requirements that are often placed on Vishay products in generic applications. Such statements are not binding statements about the suitability of products for a particular application. It is the customer's responsibility to validate that a particular product with the properties described in the product specification is suitable for use in a particular application. Parameters provided in datasheets and/or specifications may vary in different applications and performance may vary over time. All operating parameters, including typical parameters, must be validated for each customer application by the customer's technical experts. Product specifications do not expand or otherwise modify Vishay's terms and conditions of purchase, including but not limited to the warranty expressed therein.

Except as expressly indicated in writing, Vishay products are not designed for use in medical, life-saving, or life-sustaining applications or for any other application in which the failure of the Vishay product could result in personal injury or death. Customers using or selling Vishay products not expressly indicated for use in such applications do so at their own risk. Please contact authorized Vishay personnel to obtain written terms and conditions regarding products designed for such applications.

No license, express or implied, by estoppel or otherwise, to any intellectual property rights is granted by this document or by any conduct of Vishay. Product names and markings noted herein may be trademarks of their respective owners.

Material Category Policy

Vishay Intertechnology, Inc. hereby certifies that all its products that are identified as RoHS-Compliant fulfill the definitions and restrictions defined under Directive 2011/65/EU of The European Parliament and of the Council of June 8, 2011 on the restriction of the use of certain hazardous substances in electrical and electronic equipment (EEE) - recast, unless otherwise specified as non-compliant.

Please note that some Vishay documentation may still make reference to RoHS Directive 2002/95/EC. We confirm that all the products identified as being compliant to Directive 2002/95/EC conform to Directive 2011/65/EU.

Vishay Intertechnology, Inc. hereby certifies that all its products that are identified as Halogen-Free follow Halogen-Free requirements as per JEDEC JS709A standards. Please note that some Vishay documentation may still make reference to the IEC 61249-2-21 definition. We confirm that all the products identified as being compliant to IEC 61249-2-21 conform to JEDEC JS709A standards.