

Specification				
Part Number:		MCT043A12TW480272LML		
Version:				
Date:				
Revision				
No.	Date	Description	Item	Page
				

Table of Contents

1 General Specifications.....	3
2 Mechanical Diagram(T ÖVĚI HÖFGVY I Ě ĚĚ ĞŠŤ Š).....	4
3 I/O Terminal	6
3.1 Pin Description(See Datasheet of LCD Driver for detail)	6
4 Electro-optical Specifications.....	8
4.1 Absolute Maximum Ratings	8
4.2 Electrical Characteristics	8
4.3 Optical Characteristics	8
4.4 Timing Characteristics	9
4.5 Power on / off	10
5 Accessory	11
5.1 Definition and measure	11
5.2 Quality Units	12
5.3 Precautions For Use	16
5.4 Packaging	17
6 Touch Panel	18
6.1 Mechanical Characteristics	18
6.2 Optical Characteristics	18
6.3 Electric Characteristics	18
6.4 Structure And Area Definition	18
6.5 The standard Of Inspection	19

MIDAS

design • manufacture • supply

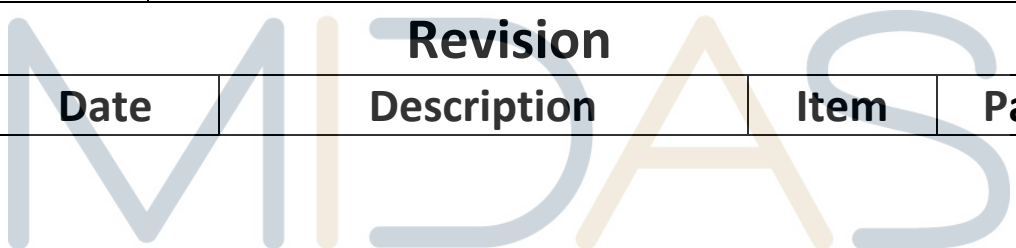
1 General Specifications

Item	Standard Value	Unit
Display Pattern	<input checked="" type="checkbox"/> Graphic <input type="checkbox"/> Character <input type="checkbox"/> Segment <input type="checkbox"/> _____ <input type="checkbox"/> with ICON	
Color	<input type="checkbox"/> Mono. <input type="checkbox"/> Grayscale <input checked="" type="checkbox"/> _65K_____	
Module Dimension (W x H x T)	105.5(W) × 111.2 (H) ×5.1 (T)	mm
Viewing Area (W x H)	\	mm
Active Area (W x H)	95.04(W)X53.856(H)	mm
Character Size (W x H)	\	mm
Character Pitch (W x H)	\	mm
Pixel Format	480(RGB)X272	
DOT Pitch (W x H)	\	mm
LCD Type	<input type="checkbox"/> TN, Positive <input type="checkbox"/> TN, Negative <input type="checkbox"/> HTN, Positive <input type="checkbox"/> HTN, Negative	
	<input type="checkbox"/> STN, Yellow-Green <input type="checkbox"/> STN, Gray <input type="checkbox"/> STN, Blue <input type="checkbox"/> FSTN, Positive <input type="checkbox"/> FSTN, Negative	
	<input type="checkbox"/> _____ <input type="checkbox"/> FM LCD <input type="checkbox"/> Color STN <input checked="" type="checkbox"/> TFT	
Polarizer Type	<input type="checkbox"/> Transflective <input checked="" type="checkbox"/> Transmissive <input type="checkbox"/> Reflective <input type="checkbox"/> Anti-Glare	
View Direction	6 O'clock	
LCD Controller & Driver	OTA5180	
LCD Driving Method	\	
Interface Type	Serial <input type="checkbox"/> I ² C <input checked="" type="checkbox"/> SPI <input type="checkbox"/> _____	
	Parallel <input type="checkbox"/> 6800 <input type="checkbox"/> 8080 <input type="checkbox"/> 4-bit <input checked="" type="checkbox"/> 16-bits RGB	
Backlight Type	<input checked="" type="checkbox"/> LED <input type="checkbox"/> Bottom <input checked="" type="checkbox"/> Single Side <input type="checkbox"/> Dual Side	
	<input type="checkbox"/> _____ <input type="checkbox"/> EL <input type="checkbox"/> CCFL	
Backlight Color	<input type="checkbox"/> Yellow-Green <input checked="" type="checkbox"/> White <input type="checkbox"/> Amber <input type="checkbox"/> Blue <input type="checkbox"/> Red <input type="checkbox"/> _____	
EL/CCFL Driver type	<input type="checkbox"/> Build-in <input type="checkbox"/> External	
DC-DC Converter	<input checked="" type="checkbox"/> Build-in <input type="checkbox"/> External	

2 Mechanical Diagram(MCT043A12TW480272LML)

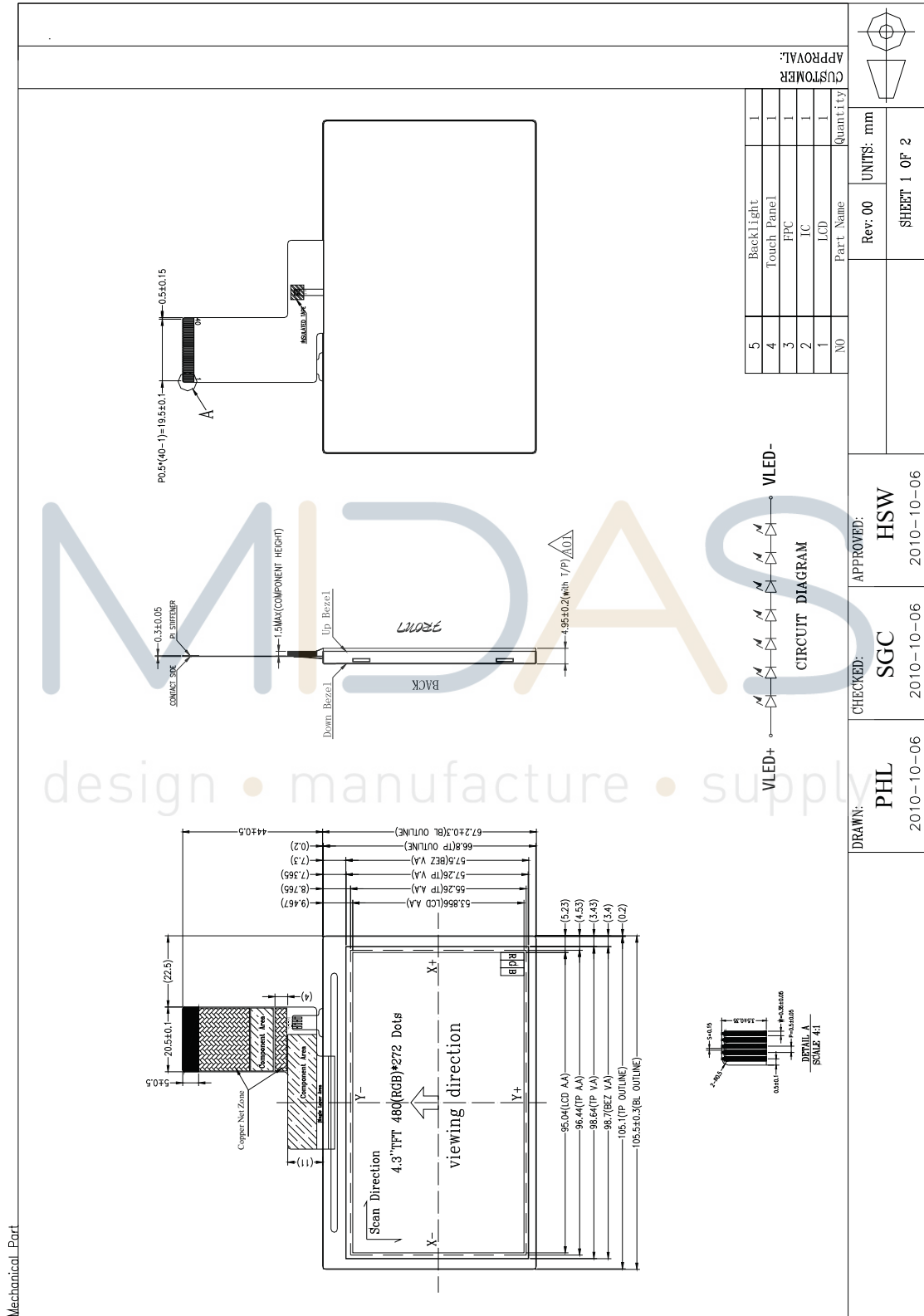

Electrical_Port

Block Diagram:

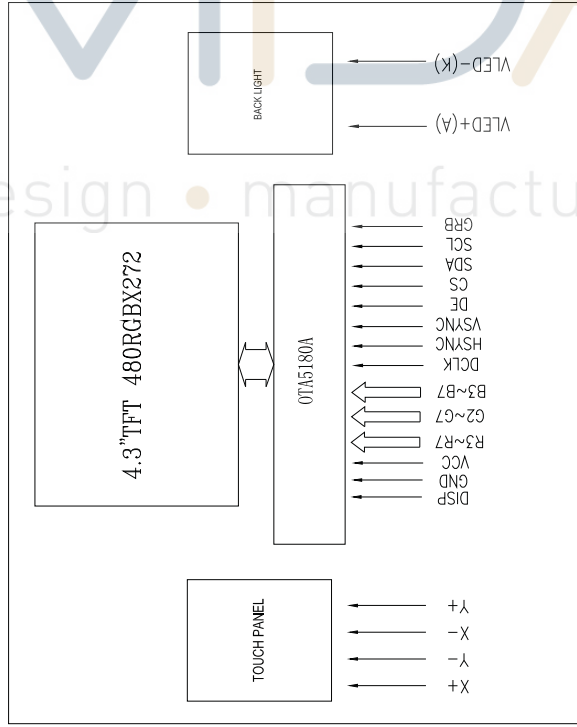

Display type:TFT/Normal white
 Display mode:Transmissive
 Viewing direction: 6:00
 Driver IC: 0TA5180A
 Interface type: 16bits RGB
 Recommend Operating Voltage: VCC=3.3V/-0.3V
 BackLight: White LED
 Vled=20.4±1.4V Iled=10mA
 Operating temprature: -20° C ~ +70° C
 Storage temprature: -30° C ~ +80° C
 All unmarked tolerance: ±0.3mm
 () REFERENCE DIMENSION
 Please kindly Confirm

Pin	Description:	Symbol	Function Description
1	GND		Ground.
2	VLED-		Power supply cathode input for backlight.
3	VLED+		Power supply anode input for backlight.
4	VCC		3.3V
5	R7		Digital data input.
6	B6		Digital data input.
7	B5		Digital data input.
8	B4		Digital data input.
9	B3		Digital data input.
10	GND		Ground.
11	G7		Digital data input.
12	G6		Digital data input.
13	G5		Digital data input.
14	G4		Digital data input.
15	G3		Digital data input.
16	G2		Digital data input.
17	GND		Ground.
18	B7		Digital data input.
19	B6		Digital data input.
20	B5		Digital data input.
21	B4		Digital data input.
22	B3		Digital data input.
23	DCLK		Clock signal.
24	GND		Ground.
25	DISP		Display on/off mode control.
26	HSYNC		Horizontal sync input.
27	VSYNC		Vertical sync input.
28	DE		Input data enable control.
29	CS		Chip select pin of serial interface.
30	SCL		Clock pin of serial interface.
31	SDA		Data input pin in serial mode.
32	NC		Non connection.
33	NC		Non connection.
34	NC		Non connection.
35	GRB		Reset pin.
36	X-		Touch Panel:left
37	Y-		Touch Panel:Up
38	X+		Touch Panel:right
39	Y+		Touch Panel:Down
40	GND		Ground.

D00: Modify Polarizer.
 A01: Modify the thickness of LCM.
 A00: Original Edition.
 Revision History:

CUSTOMER APPROVAL:

DRAWN:	TL	2010-10-06	CHECKED:	YHW	2010-10-06	APPROVED:	HSW	2010-10-06
Rev: 00	UNITS: mm							
								SHEET 2 OF 2

3 I/O Terminal

3.1 Pin Description(See Datasheet of LCD Driver for detail)

Pin NO.	Symbol	Function Description
1	GND	Ground.
2	VLED-	Power supply cathode input for backlight.
3	VLED+	Power supply anode input for backlight.
4	VCC	3.3V.
5	R7	Red pixel data input.
6	R6	Red pixel data input.
7	R5	Red pixel data input.
8	R4	Red pixel data input.
9	R3	Red pixel data input.
10	GND	Ground.
11	G7	Green pixel data input.
12	G6	Green pixel data input.
13	G5	Green pixel data input.
14	G4	Green pixel data input.
15	G3	Green pixel data input.
16	G2	Green pixel data input.
17	GND	Ground.
18	B7	Blue pixel data input.
19	B6	Blue pixel data input.
20	B5	Blue pixel data input.
21	B4	Blue pixel data input.
22	B3	Blue pixel data input.
23	DCLK	Clock signal.
24	GND	Ground.
25	DISP	Display on/off mode control. DISP=L, standby mode. DISP=H, normal display mode.
26	HSYNC	Horizontal sync input.
27	VSYNC	Vertical sync input.
28	DE	Input data enable control.
29	CSB	Chip select pin of serial interface.
30	SCL	Clock pin of serial interface.
31	SDA	Data input pin in serial mode.
32	NC	Non connection.

33	NC	Non connection.
34	NC	Non connection.
35	GRB	Reset pin.
36	X-	Touch Panel:Left.
37	Y-	Touch Panel:Up.
38	X+	Touch Panel:Right.
39	Y+	Touch Panel:down.
40	GND	Ground.



4 Electro-optical Specifications

4.1 Absolute Maximum Ratings

GND=0V

No	Item	Symbol	Min.	Typ.	Max.	Unit
1	Supply Voltage	$V_{CC}-G_{ND}$	-0.3	-	4.0	V
2	Operation Temperature	T_{OP}	-20	-	70	°C
3	Storage Temperature	T_{ST}	-30	-	80	°C

4.2 Electrical Characteristics

Ta=25°C

No	Item	Symbol	Min.	Typ.	Max.	Unit	Condition
1	Recommend Operating Voltage	$V_{CC}-G_{ND}$	3.0	3.3	3.6	V	-
2	Supply Current for IC	I_{CC}	-	16	-	mA	$V_{CC}=3.3V$
3	Current for Backlight	I_{LED}	-	10	-	mA	
4	Voltage for Backlight	V_{LED}	19.0	20.4	21.8	V	$I_{LED}=10mA$

Note: I_{LED} must be less than or equal 20 mA.

4.3 Optical Characteristics

Ta = 25°C, VCC=3.3V, GND=0V, $I_{LED} = 10$ mA

ITEM	SYMBOL	CONDITION	MIN	TYP	MAX	UNIT	DRIVE	
Response time	T_r+T_d	$\theta = \phi = 0^\circ$	-	20	-	ms		
Contrast ratio	CR	$\theta = \phi = 0^\circ$	-	(400)	-			
Uniformity	U	-	70	-	-	%		
Surface Luminance	L_v	$\theta = \phi = 0^\circ$	-	200	-	cd/m ²		
Viewing angle range	6H $\phi=270^\circ$	CR \geq 10	$\theta 1$	-	55	-	deg.	(1)
	12H $\phi=90^\circ$		$\theta 2$	-	70	-		
	$\phi=0^\circ$		$\theta 3$	-	70	-		
	$\phi=180^\circ$		$\theta 4$	-	70	-		
Chromaticity Coordinates	White	X	$\theta = \phi = 0^\circ$	0.2746	0.3146	0.3546	-	(2)
		Y		0.3185	0.3585	0.3985		
	Red	X	$\theta = \phi = 0^\circ$	0.5552	0.5952	0.6352		
		Y		0.2912	0.3312	0.3712		
	Green	X	$\theta = \phi = 0^\circ$	0.3131	0.3531	0.3931		
		Y		0.5388	0.5788	0.6188		
Blue	X	$\theta = \phi = 0^\circ$	0.1090	0.1490	0.1890			
	Y		0.0988	0.1388	0.1788			

Note :

- (1) Duty driving by DMS505.
- (2) Duty driving by Actual driver IC.

4.4 Timing Characteristics

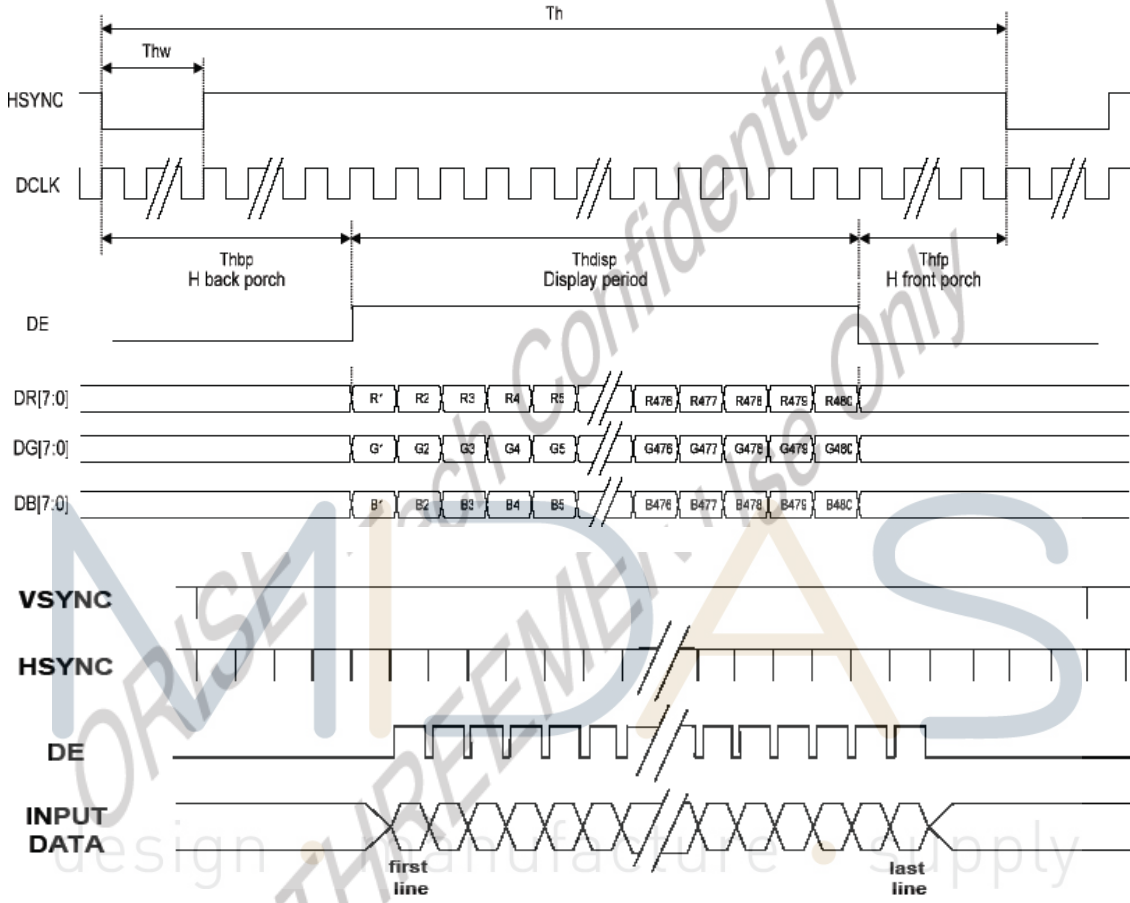

SYNC-DE Mode Timing Diagram

Item	Symbol	Min.	Typ.	Max.	Unit		
DCLK Frequency	Fclk	5	9	12	MHz		
DCLK Period	Tclk	83	110	200	ns		
Hsync	Period Time	Th	490	531	605	DCLK	
	Display Period	Thdisp		480		DCLK	
	Back Porch	Thbp	8	43		DCLK	By H_BLANKING setting
	Front Porch	Thfp	2	8		DCLK	
	Pulse Width	Thw	1			DCLK	
Vsync	Period Time	Tv	275	288	335	H	
	Display Period	Tvdisp		272		H	
	Back Porch	Tvbp	2	12		H	By V_BLANKING setting
	Front Porch	Tvfp	1	4		H	
	Pulse Width	Tvw	1	10		H	

4.5 Power on / off

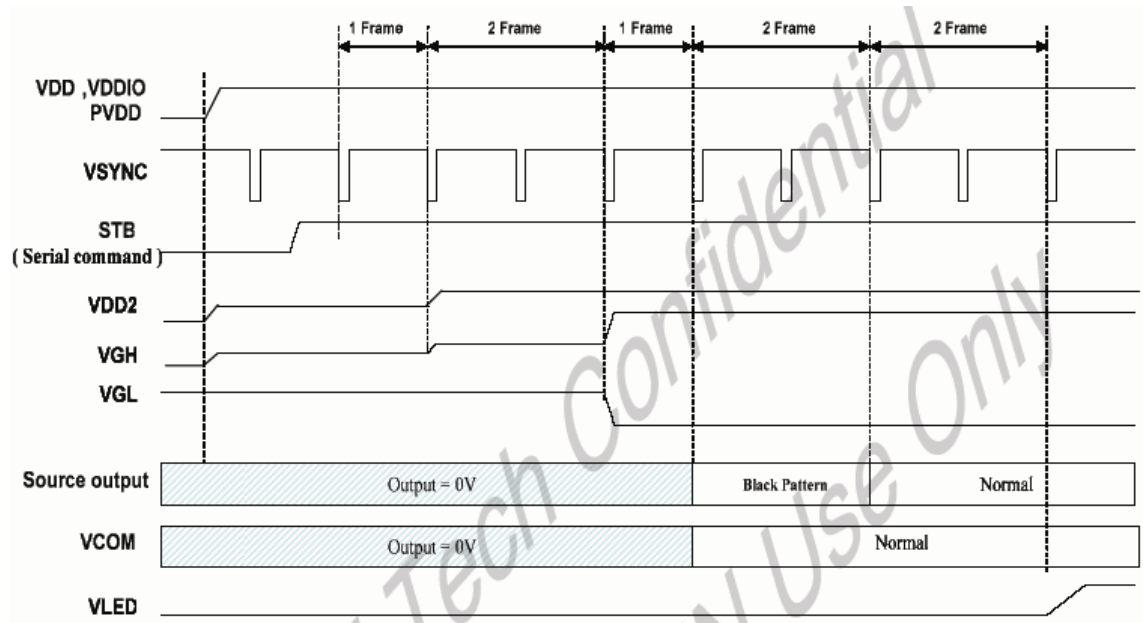

Power On Sequence

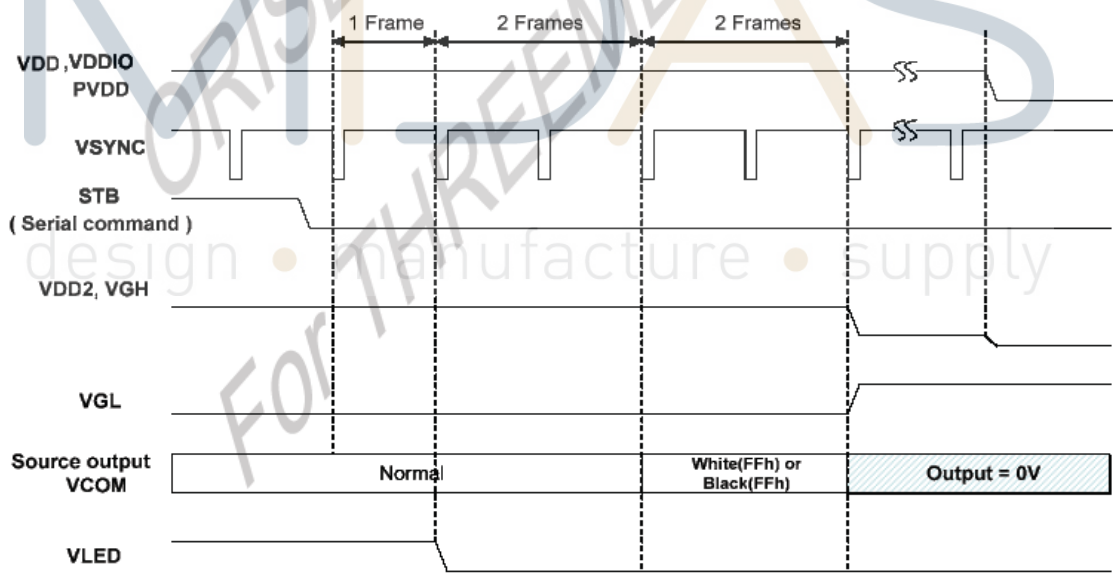

Power Off Sequence

5 Accessory

5.1 Definition and measure

5.1.1 Definition of response time

Measuring apparatus: DMS505

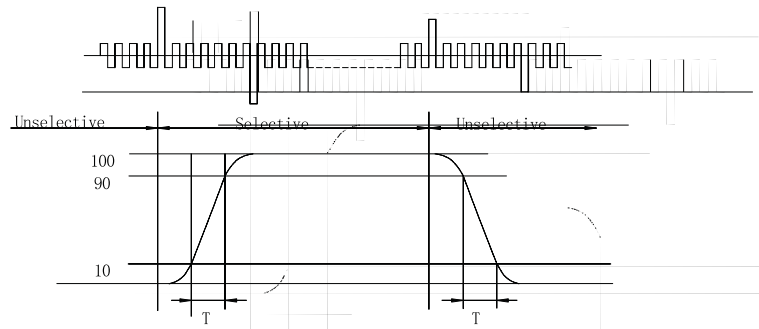

5.1.2 Definition of contrast ratio

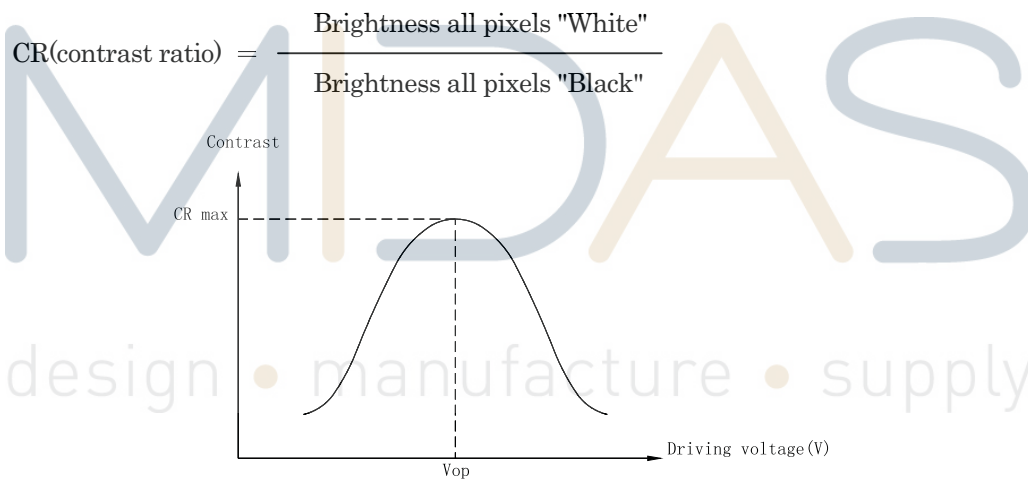

5.1.3 Definition of viewing angle

Measuring mode: Transmissive

Measuring apparatus: DMS-505

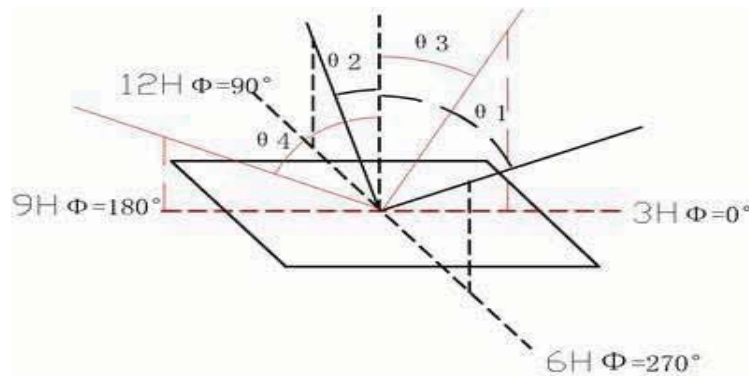

5.1.4 Definition of color Gamut

Color gamut: $S = (\text{RGB triangle Area} / \text{NTSC triangle Area}) \times 100$

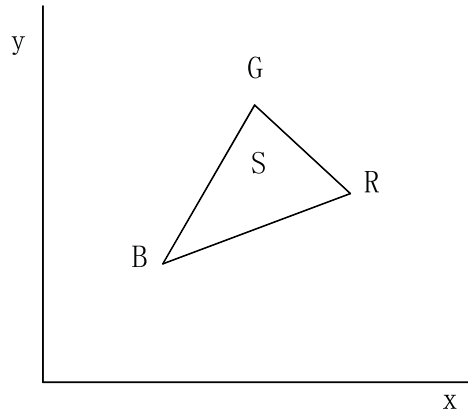

5.2 Quality Units

Light Source: Fluorescent light (Day-light Type) 20~40W

Distance: 30cm~50cm from inspector eyes to display surface. The viewing angle should be perpendicular to display surface.

Definition of Active Area, Viewing Area & Invisible Area

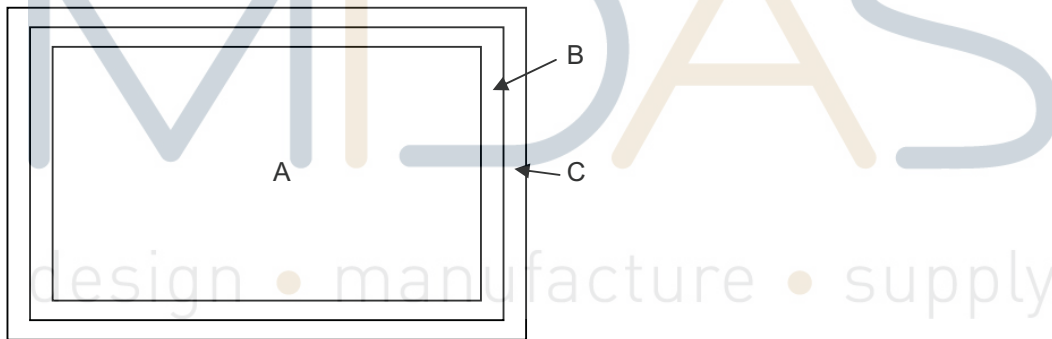

A: Active Area (A.A.)

B: Viewing Area (V.A.)

C: Invisible Area (I.A.: After assembly by customer, this area is invisible. Cosmetic defect on this area must be ignored.)

Sampling Plan

Reference Standard GB2828 (MIL-STD-105E) General Inspection Level II

Defect Class Definition and AQL

Class	Defect Description	AQL
Major	No display, Missing lines, Abnormal display, No backlight, Dimension out of specification	0.4
Minor	Black/white dots, chip glass, Bright/Dark dot when testing, Air bubble, Line type defect(Bright or Dark), Bubble between polarizer and glass	1.0

5.2.1 Inspection Standard

5.2.1.1 Definition of dot defect (Pixel defect)

1) Pixel and sub-pixel (Refer to below illustration)



A pixel = (R sub-pixel + G sub-pixel + B sub-pixel)

2) The definition of dot: The size of a defective dot over 1/2 sub-pixel should be regarded as one defective dot.

3) Bright dot: Dots appear bright and unchanged in size in which LCD panel is displaying under black pattern.

4) Dark dot: Dots appear dark and unchanged in size in which LCD panel is displaying under pure R/G/B pattern.

5) Two dots adjacent (Refer to below illustration)



2 dot adjacent (Left-right) 2 dot adjacent (Top-down) 2 dot adjacent (Diagonal)

* In this section: black dot express defective dot; grey dot express normal dot.

5.2.1.2 Dot Defect (Bright Dot / Dark Dot)

Defect Description	Illustration	Judgment Criteria	Acceptable Defect Qty.		Class
			V.A. & A.A.	I.A.	
Bright Dot	OK black Pattern: All R/G/B Dark Bright Green Dot: R/G/B should be dark at black pattern, but G is bright.	Bright R/G/B dot 2 dots adjacent	2	NA	Minor
			0		
Dark Dot	OK White pattern: All R/G/B Bright Dark Green Dot: R/G/B should be bright at white pattern, but G is dark.	Dark R/G/B Dot 2 dots adjacent	3	NA	Minor
			1		
Remark	1. Total dot defect quantity should be equal or less than 4.				

5.2.1.3 Appearance inspection

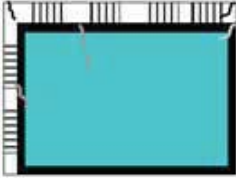
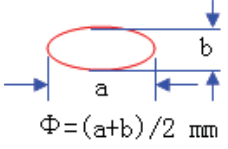
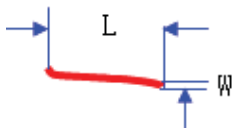
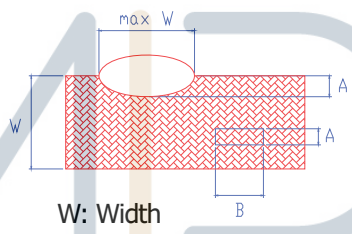
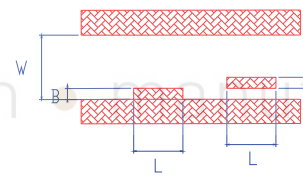
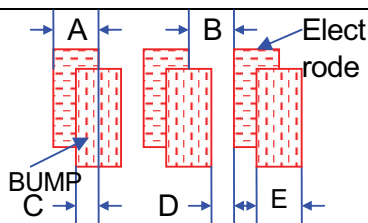
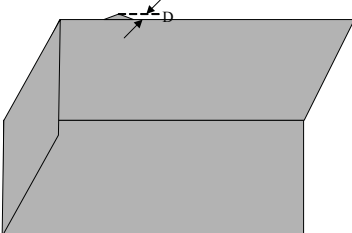
Defect Description	Illustration	Judgment Criteria	Class
Glass crack		Not allowed	Minor
Circular type defect (Black spot / White spot)		$\Phi \leq 0.15\text{mm}$, ignored	Minor
		$0.15\text{mm} < \Phi \leq 0.50\text{mm}$, $N \leq 4$	
		$\Phi > 0.50\text{mm}$, NG	
Line type defect		$W \leq 0.05\text{mm}$ & $L \leq 0.3\text{mm}$, Ignored	Minor
		$0.05\text{mm} < W \leq 0.10\text{mm}$, $0.3\text{mm} < L \leq 2.0\text{mm}$, $N \leq 4$	
		$W > 0.1\text{mm}$ or $L > 2.0\text{mm}$, NG	
FPC Defect: Pinhole, damage on circuit		$A \leq W/4$ & $B \leq 3W$, ignored $A > W/4$ or $B > 3W$, NG	Major
FPC Defect: Etching defect (Protrude/Copper residue/burr)		$B \leq W/4$ & $L \leq 3W$, irremovable, ignored $B > W/4$ or $L > 3W$, removable, NG	Major
FPC Defect: Crease/Impress	NA	Crease with an acute angle, NG Crease or impress with an obtuse angle, ignored	Minor
SMT: Component shift		$C \geq E/2$ & $D \geq B/2$, ignored $C < E/2$ or $D < B/2$, NG	Minor
Metal Frame		Burr was allowed at edges within the dimension as below: $D < 0.05\text{mm}$, ignored $D \geq 0.05\text{mm}$, NG	Minor
Remark	For unmentioned FPC defect, please refer to IPC-6013 For unmentioned SMT defect, please refer to IPC-A-610		

5.2.1.4 Function defect

Defect Description	Illustration	Judgment Criteria	Class
Line defect	Vertical lines Horizontal lines Cross lines etc	Not allowed	Major
Display defect	Abnormal display No display etc	Not allowed	Major

5.2.2 Reliability Test

5.2.2.1 Standard Specifications for Reliability

5.2.2.1.1 Test method

There should be no existing conspicuous failure of functions and appearance in LCD after the following tests.

NO	Item	Description
1	Low Temperature Operating	The sample should be allowed to stand at $(-20 \pm 2)^{\circ}\text{C}$ for 96 Hours under driving condition.
2	High Temperature Operating	The sample should be allowed to stand at $(70 \pm 2)^{\circ}\text{C}$ for 96 Hours under driving condition.
3	Low Temperature Storage	The sample should be allowed to stand at $(-30 \pm 3)^{\circ}\text{C}$ for 96 Hours under no-load condition, and then returning it to normal temperature condition, and allowing it stand for 24 hours
4	High Temperature Storage	The sample should be allowed to stand at $(80 \pm 2)^{\circ}\text{C}$ for 96Hours under no-load condition, and then returning it to normal temperature condition, and allowing it stand for 24 hours
5	Moisture resistance	The sample should be allowed to stand at $(40 \pm 2)^{\circ}\text{C}$, $(90 \pm 2)\% \text{RH}$ for 96Hours under no-load condition excluding the polarizer, then taking it out and drying it at normal temperature, and allowing it stand for 24 hours
6	Thermal Shock Resistance	The sample should be allowed to stand the following 5 cycles of operation: T_{STL} for 30 minutes -> normal temperature for 5 minutes -> T_{STH} for 30 minutes -> normal temperature for 5 minutes, as one cycle, then taking it out and drying it at normal temperature, and allowing it stand for 24 hours

5.2.2.1.2 Testing Conditions and Inspection Criteria:

For the final test, the testing sample must be stored at room temperature for 24 hours, after the tests listed above; Standard specifications for Reliability have been executed in order to ensure stability.

NO.	Item	Inspection Criteria
1	Current Consumption	The current consumption should be under double of initial test.
2	Contrast	The contrast must be larger than half of initial test.
3	Appearance	Appearance defects should not happen.

5.2.2.2 Life Time:

Functions, performance, appearance, etc. shall be free from remarkable deterioration within 50,000 hours under ordinary operating and storage conditions room temperature ($25\pm 10^{\circ}\text{C}$), normal humidity ($45\pm 20\%RH$), and in area not exposed to direct sunlight. Definition on the termination of life time is deterioration of contrast ratio by one fifth against initial value or human eyes can not recognize each dots.

TP life: 250gf, 2t/s, 1,000,000t, R12.5mm Silicon rubber.

5.3 Precautions For Use

5.3.1 Recommended storage condition: 50-60%RH, $25\pm 5^{\circ}\text{C}$;

5.3.2 TFT LCD is brittle. It may break when it is dropped or bumped on a hard surface.

Please handle carefully.

5.3.3 Please don't clean polarizer by alcohol or acetone. Pure water is recommended.

5.3.4 Please don't disassembly the module, it will invalidate the warranty agreements.

Please use it within 6 months.

5.3.5 This product is ESD sensitive. Please assure enough ESD protection whenever handling the product.

MIDAS

design • manufacture • supply

5.4 Packaging

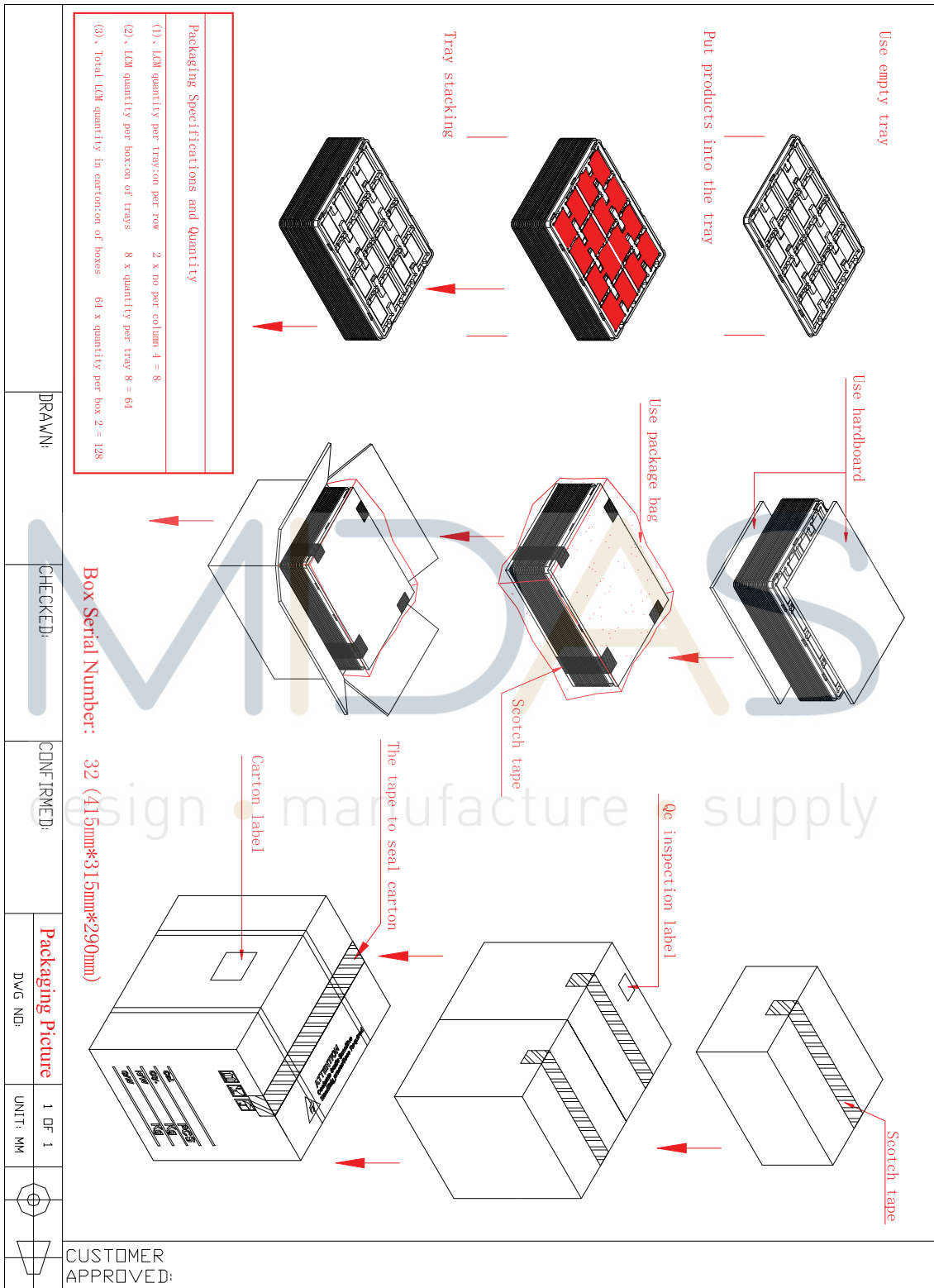

6 Touch Panel

6.1 Mechanical Characteristics

Items	Value	
Operation Force	≤60g	
Operation Life	Tapping Durability	≥1,000,000 times
	Pen sliding Durability	≥100,000 times
Surface Hardness	≥3H	

Operation force is defined as the minimum force it makes the contact resistance stable when tapped with a 0.8mm radius rigid tip.

6.2 Optical Characteristics

Items	Value
Transparency	77%(typ.)
Haze	8%(typ.)

6.3 Electric Characteristics

Items	Value	
Max Voltage	5V (DC)	
Max Current	Top Layer	5.5~25mA
	Bottom Layer	5.5~25mA
Terminal Resistance	Rx:200-900Ω, Ry:200-900Ω	
Insulation Resistance	≥10MΩ(25V DC)	
Linearity	≤1.5%	
Chattering Time	≤15ms	

6.4 Structure And Area Definition

The structure and the performance guaranteed areas of this touch panel are defined below:

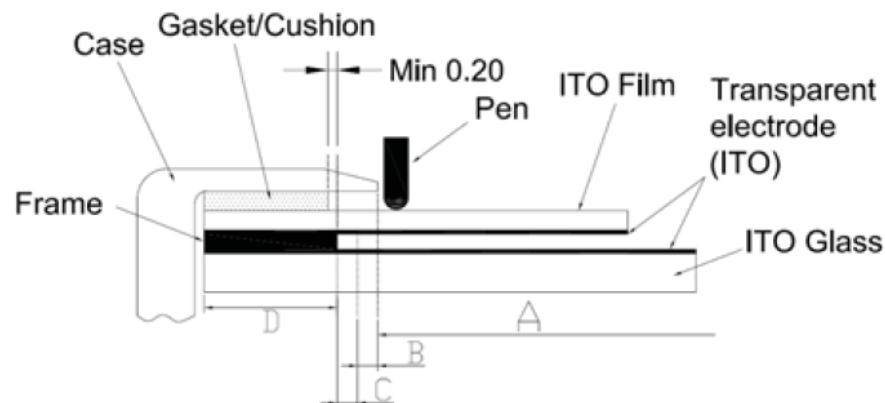

Area A: Active area

The area guarantees a touch panel operation with the following characteristics when pressed, (1)Operation force, (2) Electric characteristics, (3) Tapping durability, (4) Pen sliding durability,

Area B: Operation non-guaranteed area

The area does not guarantee a touch panel operation and its function. When this area is pressed, touch panel shows degradation of its performance and durability such as a pen sliding durability becomes about one-tenth compared with the active area (Area A) and its operation force requires about double. About 0.5mm outside from the boundary of the active area corresponds to this area.

Area C: Pressing prohibition area

The area forbids pressing because an excessive load is applied to the transparent electrode and a serious damage will be given to the touch panel function. About 0.5mm outside from the boundary of “Area B” corresponds to this area.

Area D: Non-Active area (Frame)

This area does not activate even if pressed.

Area B and Area C: Sensitive area

Area B and Area C both belong to the sensitive area. This area has a clearance between top and bottom contact side. Great press resulting in transparent electrode cracks, function defect to be exact, will deform surface transparent electrode. Please think about structure of sensitive area and case in order to avoid terminal user to fail to touch this area.

6.5 The standard Of Inspection**6.5.1 Purpose**

This specification is made to be used as the standard acceptance/rejection criteria for Touch panel.

6.5.2 Mechanical characteristics

Test Items	Specifications	Remarks
Tapping Durability	$\geq 1,000,000$ times(4-wire) $\geq 35,000,000$ times(5-wire) Test condition: Hitting head: Rubber, Tip R=12.5mm Hardness: 60 deg. Load: 250gf Hitting frequency: 2 times/s	Tapping at the same point.
Pen Sliding Durability	$\geq 100,000$ times(4-wire) $\geq 1,000,000$ times(5-wire) Test condition: Hitting head: Polyacetal, Tip R=1.0mm Load: 100gf Sliding speed: 60mm/s	Sliding the same position.
Impact Resistance	No glass breaks when $\Phi=9$ mm steel ball is dropped vertically on the center of the touch panel from 100cm height at a single time. Thickness of glass: 0.7~3.0mm	Only for Film + Glass type touch panel.

6.5.3 Physical characteristics

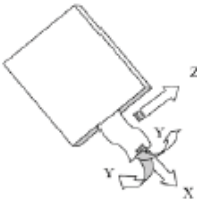
Test Items	Specifications	Remarks
Surface Hardness	Typically between 2~4H depending on hard coat used, Pressure 500gf, 45 deg.	Pencil hardness
Operation Force	Typically less than 100g Tip R=0.8mm polyacetal pen	
FPC Heat Seal Peeling Strength	X: $\geq 2000g$ Y: $\geq 500g$ Z: $\geq 150g$ 	
	Combination force between FPC and substrate	

6.5.4 Visual Inspection Requirement

●Definition

1. MA: All functional defects such as open, short, contrast differential, excess power consumption, smearing leakage, etc. And overall outline dimension beyond the drawing are classified as MA
2. MI: Except the MA defects above, all appearance defects are classified as MI.
3. Denseness: More than 2 defects (including 2 defects) in 5mm area.



● Inspection condition



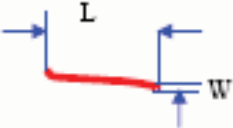
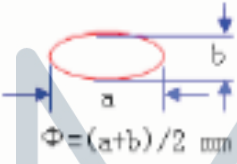

Source of the lighting for inspection is 12~20W cool white color of fluorescent light for 400~500mm long between product and a source of light. The viewing distance for inspection between eyes and product is 300mm. The viewing angle between eyes and product is kept in

30~45°. Meanwhile, add a black cardboard under the product as background. Inspection time is less than 10 sec for each piece. And we check product with protective film.

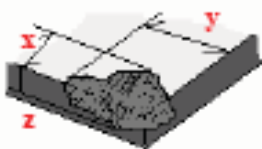
● Details

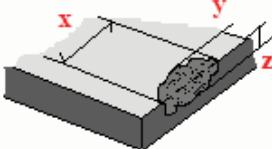
(The criteria are for Viewing Area, and the defects in non-VA part wouldn't be considered.)

Items	Inspection		Classification of defects	
			MA	MI
Scratch 	Criteria	Quantity Accepted		☆
	$W \leq 0.03\text{mm}$	Ignored		
	$0.03\text{mm} \leq W \leq 0.05\text{mm}$, $L \leq 10\text{mm}$ Distance from any other scratch or foreign object $> 20\text{mm}$	Ignored		
	$0.03\text{mm} \leq W \leq 0.05\text{mm}$, $L \leq 10\text{mm}$ Distance from any other scratch or foreign object $< 20\text{mm}$	3		
	$W > 0.05\text{mm}$, or $L > 10\text{mm}$	0		
Spot Defect 	Criteria	Quantity Accepted		☆
	$\Phi \leq 0.1\text{mm}$, no denseness	Ignored		
	$0.1\text{mm} < \Phi \leq 0.15\text{mm}$, no denseness	3		
	$0.15\text{mm} < \Phi \leq 0.25\text{mm}$, no denseness	2		
	$\Phi > 0.25\text{mm}$	0		
Linear Defect 	Criteria	Quantity Accepted		☆
	$W \leq 0.025\text{mm}$	Ignored		
	$0.025\text{mm} < W \leq 0.035\text{mm}$, $L \leq 5\text{mm}$ Distance from any other foreign object or scratch $> 20\text{mm}$	Ignored		
	$0.025\text{mm} < W \leq 0.05\text{mm}$, $L \leq 5\text{mm}$ Distance from any other foreign object and scratch $< 20\text{mm}$	2		
	$W > 0.05\text{mm}$, or $L > 5\text{mm}$	0		
Corner Fragment 	Criteria	Decision		☆
	$X \leq 3.0\text{mm}$, $Y \leq 3.0\text{mm}$, $Z \leq t$ t: Thickness of the glass	Acceptable		
Side Fragment	Criteria	Decision		☆

	$X \leq 6.0\text{mm}$, $Y \leq 2.0\text{mm}$, $Z \leq t$ t: Thickness of the glass	Acceptable		
Crack Inward Outward 	Criteria Any crack inward Crack outward	Decision Unacceptable Acceptable		☆
Newton Ring (Regular) 	Criteria The area of the Newton ring is more than 1/3 area of the touch panel, or character affected and line distorted occurs after touch panel lightening The area of the Newton ring is less than 1/3 area of the touch panel, and no character affected and line distorted after touch panel lightening.	Decision Unacceptable Acceptable		☆
Newton Ring (Irregular) 	Criteria The area of the Newton ring is more than 1/4 area of the touch panel, or character affected and line distorted occurs The area of the Newton ring is less than 1/4 area of the touch panel, or no character affected and line distorted after touch panel lightening	Decision Unacceptable Acceptable		☆
Product Color	According to the sample confirmed		☆	