

NTC SMD Thermistors

With Nickel Barrier Termination NB 21

Chip thermistors are high quality and low cost devices especially developed for surface mounting applications. They are widely used for temperature compensation but can also achieve temperature control of printed circuits.

A nickel barrier metallization provides outstanding qualities of solderability and enables this chip to meet the requirements of the most severe soldering processes.

Types	NB 21 IEC SIZE : 0603
DIMENSIONS: millimeters (inches)	
Terminations	Nickel Barrier
Marking	On packaging only
Climatic category	40/125/56
Operating temperature	-55°C to +150°C
Tolerance on R _n (25°C)	±5%, ±10%, ±20%
Maximum dissipation at 25°C	0.07 W
Thermal dissipation factor	1 mW/°C
Thermal time constant	4 s

Resistance - Temperature characteristics: pages 29 to 33.

APPLICATIONS

- LCD compensation
- Battery packs
- Mobile phones
- CD players
- Heating systems
- Air-conditioning systems
- Temperature control of Switch Mode Power Supplies
- Compensation of pressure sensors
- Protection of power transistors in various electronic circuits

HOW TO ORDER



NB 21

Type

K 0

Material Code
K
(See tables page 15)

0103

Resistance
10,000 Ω

M

Tolerance
M (±20%)
J (±5%)
K (±10%)

BB

Suffix: Packaging
--: Bulk
BB: Cardboard tape
(180mm diam. reel)
BF: Cardboard tape (1/2 reel)
BD: Cardboard tape
(330mm diam. reel)

NTC SMD Thermistors

With Nickel Barrier Termination NB 21

TABLE OF VALUES

NB 21 IEC SIZE : 0603				
Types	Rn at 25°C (Ω)	Material Code	B (K) (1) ± 5% (ΔB/B (2) ± 3%)	α at 25°C (%/°C)
NB 21 KC 0 470 NB 21 KC 0 101 NB 21 KC 0 471	47 100 470	KC	3470 ± 5%	- 3.9
NB 21 MC 0 102	1,000	MC	3910 ± 3%	- 4.4
NB 21 J 0 0472	4,700	J	3480 ± 3%	- 3.9
NB 21 J 5 0682 NB 21 J 5 0103	6,800 10,000	J5	3480 ± 3% 3480 ± 3%	- 3.9 - 3.9
NB 21 K 0 0103 NB 21 K 0 0153	10,000 15,000	K	3630 ± 3%	- 4.0
NB 21 L 0 0223	22,000	L	3790 ± 3%	- 4.2
NB 21 M 0 0333 NB 21 M 0 0473	33,000 47,000	M	3950 ± 3%	- 4.4
NB 21 L 2 0683	68,000	L2	3805 ± 3%	- 4.1
NB 21 N 0 0683	68,000	N	4080 ± 3%	- 4.6
NB 21 N 5 0104	100,000	N5	4160 ± 3%	- 4.7
NB 21 P 0 0154	150,000	P	4220 ± 3%	- 4.7
NB 21 Q 0 0334 NB 21 Q 0 0474	330,000 470,000	Q	4300 ± 3%	- 4.7

Packaging for Automatic Insertion

NTC Chip Thermistors / NC/NB Series



AUTOMATIC INSERTION

Super 8 Plastic Tape Packaging:

The mechanical and dimensional reel characteristics are in accordance with the IEC publication 286-3.

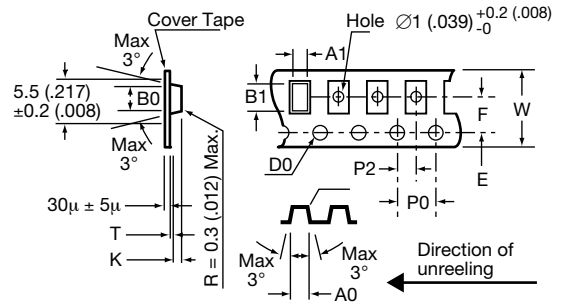

Designation	Symbol	Value	Tolerance	
Tape width	W	8	±0.2	
Tape thickness	T	0.4 max.		
Pitch of the sprocket holes	P0	4	±0.1	
Diameter of the sprocket holes	D0	1.5 -0	±0.1	
Distance	E	1.75	±0.1	
Distance (center to center)	F	3.5	±0.05	
Distance (center to center)	P2	2	±0.1	
Sizes of the cavities	NC 12 (0805)	A0	1.5	±0.1
		B0	2.4	±0.1
		K	1.4 max.	K ±0.1 (size is adjustable) (K = t1 +0.2)
NC 20 (1206)		A0	1.95	±0.1
		B0	3.55	±0.1
		K	1.5 max.	K ±0.1 (size is adjustable) (K = t1 +0.2)

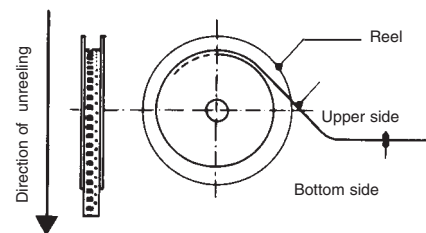
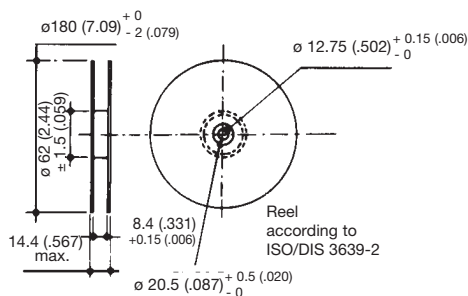

QUANTITY PER REEL

Type	Suffix	Qty Per Reel
NC - NB 12	BA	4000
	BE	2000
NC 20 - NB 20	BA	3000
	BE	1500

Packaging for Automatic Insertion

NTC Chip Thermistors / NC/NB Series



AUTOMATIC INSERTION

8mm Paper Tape Packaging:

The mechanical and dimensional reel characteristics are in accordance with the IEC publication 286-3.

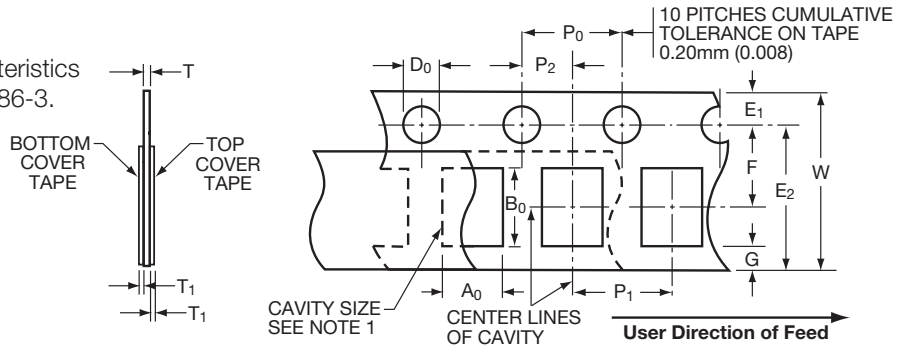

Designation	Symbol	Value	Tolerance
Tape width	W	8	$-.0.1/+0.3$
Tape thickness	T	1.1 max.	
Pitch of the sprocket holes	P_0	4	± 0.1
Diameter of the sprocket holes	D_0	$-0/+0.1$	± 0.1
Distance	E_1	1.75	± 0.1
Distance (center to center)	F	3.5	± 0.05
Distance (center to center)	P_2	2	± 0.05
Cover tape thickness	T_1	0.10 max.	
Distance	E_2	6.25 min.	
Distance	G	0.75 min.	
Component pitch	P_1	0805/0603	± 0.1
		0402	± 0.1

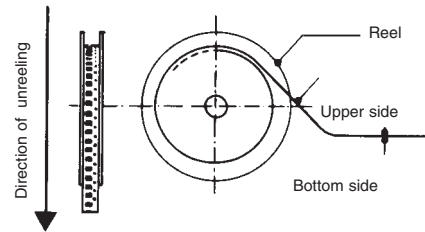
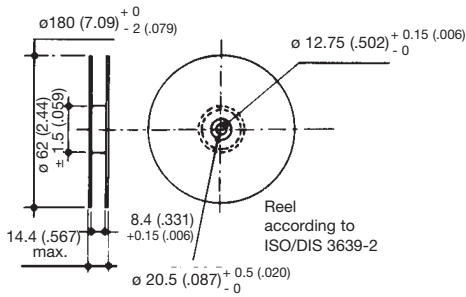

QUANTITY PER REEL

Type	Suffix	Qty Per Reel
NB - NC 12	BB	4000
NB 21	BF	2000

Surface Mounting Guide

Chip Thermistor – Application Notes

STORAGE

Good solderability is maintained for at least twelve months, provided the components are stored in their “as received” packaging at less than 40°C and 70% RH.

SOLDERABILITY / LEACHING

Terminations to be well soldered after immersion in a 60/40 tin/lead solder bath at $235 \pm 5^\circ\text{C}$ for 2 ± 1 seconds.

Terminations will resist leaching for at least the immersion times and conditions recommendations shown below.

P/N	Termination Type	Solder Tin/Lead	Solder Temp °C	Immersion Time Seconds
NC	AgPdPt	60/40	260 ± 5	15 max
NB	Nickel Barrier	60/40	260 ± 5	30 ± 1

NB products are compatible with a wide range of soldering conditions consistent with good manufacturing practice for surface mount components. This includes Pb free reflow processes with peak temperatures up to 270°C . Recommended profiles for reflow and wave soldering are shown below for reference.

NC products are recommended for lead soldering application or gluing techniques.

Wave

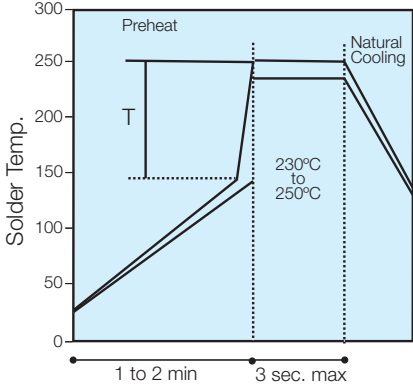

(Preheat chips before soldering)
T/maximum 150°C

- The visual standards used for evaluation of solder joints will need to be modified as lead free joints are not as bright as with tin-lead pastes and the fillet may not be as large.
- Resin color may darken slightly due to the increase in temperature required for the new pastes.
- Lead-free solder pastes do not allow the same self alignment as lead containing systems. Standard mounting pads are acceptable, but machine set up may need to be modified.

Reflow

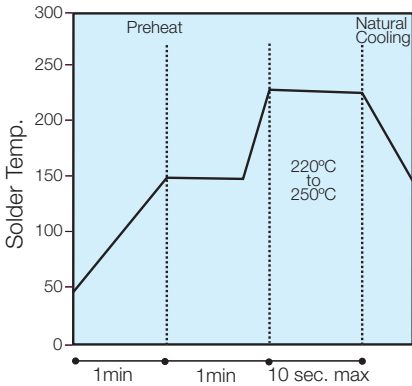

(Minimize soldering time)

RECOMMENDED SOLDERING PAD LAYOUT

Dimensions in mm (inches)

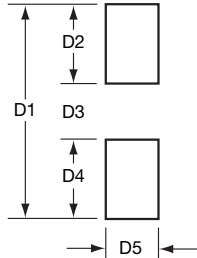

REFLOW SOLDERING

Case Size	P/N	D1	D2	D3	D4	D5
0603	NB21	2.30 (.091)	0.80 (.031)	0.70 (.028)	0.80 (0.31)	0.75 (.030)
0805	NB12	3.00 (.118)	1.00 (.039)	1.00 (.039)	1.00 (.039)	1.25 (.049)
1206	NB20	4.00 (.157)	1.00 (.039)	2.00 (.079)	1.00 (.039)	2.50 (.098)

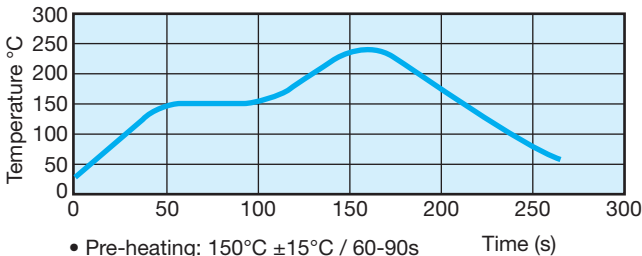

- Pre-heating: $150^\circ\text{C} \pm 15^\circ\text{C}$ / 60-90s
- Max. Peak Gradient: 2.5°C/s
- Peak Temperature: $245^\circ\text{C} \pm 5^\circ\text{C}$
- Time at $>230^\circ\text{C}$: 40s Max.

WAVE SOLDERING

Case Size	P/N	D1	D2	D3	D4	D5
0603	NB21	3.10 (.122)	1.20 (.047)	0.70 (.028)	1.20 (.047)	0.75 (.030)
0805	NB12	4.00 (.157)	1.50 (.059)	1.00 (.039)	1.50 (.059)	1.25 (.049)
1206	NB20	5.00 (.197)	1.50 (.059)	2.00 (.079)	1.50 (.059)	1.60 (.063)