

BB-EPH1800

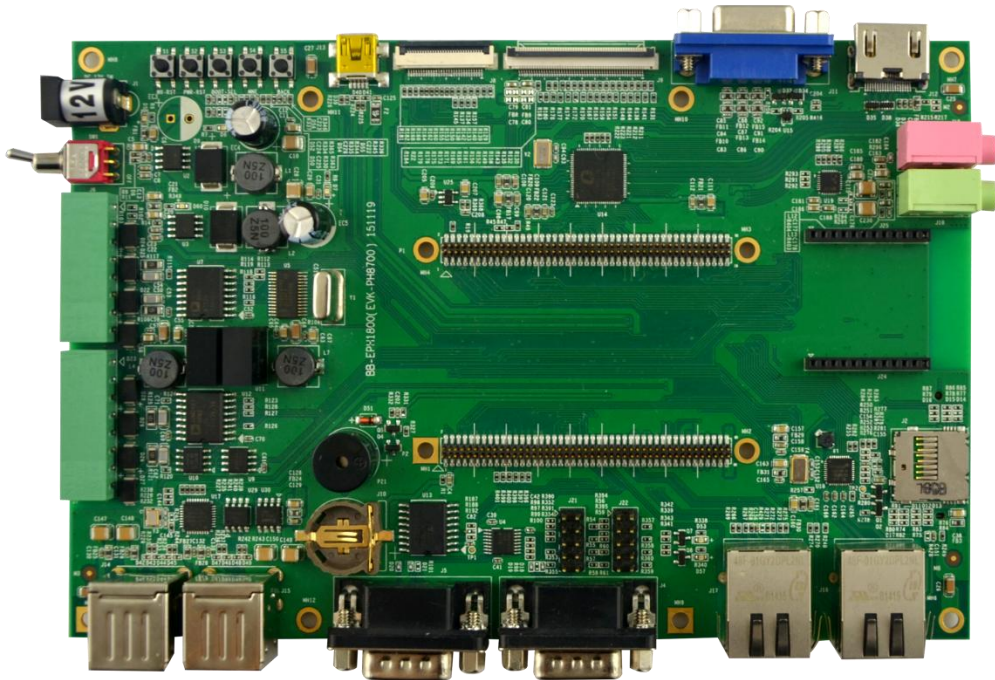

User Manual

Version 1.0–March 2016

Copyright Statement:

- BB-EPH1800 and its related intellectual property are owned by Shenzhen Embest Technology Co., Ltd.
- Shenzhen Embest Technology has the copyright of this document and reserves all rights. Any part of the document should not be modified, distributed or duplicated in any approach and form with the written permission issued by Embest Technology Co., Ltd.

Disclaimer:

- Shenzhen Embest Technology does not take warranty of any kind, either expressed or implied, as to the program source code, software and documents in the CD/DVD-ROMs provided along with the products, and including, but not limited to, warranties of fitness for a particular purpose; The entire risk as to the quality or performance of the program is with the user of products.

Revision History:

Version	Date	Description
1.0	2015-12-25	

Table of Contents

Chapter 1	Product Overview	1
1.1	Brief Introduction	1
1.1.1	Packing List.....	1
1.1.2	Product Features	2
1.2	Interfaces & Buttons.....	3
1.3	System Block Diagram.....	4
1.4	Product Dimensions(mm)	5
Chapter 2	6
Introduction to Hardware System	6
2.1	Overview of CPU	6
2.2	Introduction to Peripheral Chips	6
2.2.1	CH7033	6
2.2.2	AR8035	7
2.3	Details of Interfaces	7
2.3.1	PH180 Interfaces	7
2.3.2	LCD/VGA/HDMI	15
2.3.3	CAMERA.....	18
2.3.4	Gigabit Ethernet.....	19
2.3.5	TF Card.....	20
2.3.6	USB & HUB.....	21
2.3.7	Wifi	22
2.3.8	UART&RS485&CAN.....	23
2.3.9	Button.....	23
2.3.10	UART	23
2.3.11	LED	24
2.3.12	RTC.....	24
2.3.13	External Button	24
Technical Support and Warranty	25

Chapter 1 Product Overview

1.1 Brief Introduction

BB-EPH1800 is an evaluation base board designed by Embest for PH180 related SOM modules for areas such as medical instruments, video surveillance and industrial control. BB-EPH1800 provide lots of external interface for PH8700/PH8800, and has 4 high-speed USB2.0 Host interfaces, a OTG interface, a TF card slot for mass storage, a 12-bit camera interface, a VGA interface, 2 Gigabit Ethernet, a 24-bit LCD interface, WIFI, Mic input, Audio output, Uart, Can, Rs485 and so on. Meanwhile, it has two 5Pin on-board DIP switches include UART, I2C, SPI used to do the function extension.

1.1.1 Packing List

- | | |
|------------------------------------|------------------|
| ● SOM-PH8700/SOM-PH8800 Core Board | X1(one of two) |
| ● BB-EPH1800 Evaluation Board | X1 |
| ● WIFI Module | X 1 (optional) |
| ● 12V 2A DC Power Adapter | X1 |
| ● 8GB TF card | X1 |
| ● 4.3 inch LCD or 7 inch LCD Panel | X1 (optional) |
| ● HDMI Connection Cable | X1 |
| ● Uart Connection Cable | X1 |
| ● USB OTG Connection Cable | X1 |
| ● Ethernet Connection Cable | X1 |

1.1.2 Product Features

- **General Specifications:**
 - Operating Temperature: 0~70°C
 - Power Supply: 9~25V
 - Operating Humidity: 20% ~ 90%
 - Dimensions: 180 mm×120 mm
 - PCB Layers: 4Layers
- **Data Transfer Interfaces:**
 - A DB9 RS232 Uart
 - A 12 bit Digital Camera
 - Two Gigabit Ethernet (RJ45)
 - Three RS485
 - Two CAN
 - Four high-speed USB2.0 Host interfaces
 - A USB OTG
 - A TF Card
 - A Wifi Module
 - 2 ↑ 10 Pin External Interface (I2C.UART.SPI and so on)
- **Debugging Interfaces**
 - Support UART serial debugging
- **Audio/Video Interfaces:**
 - A 24-bit true-color LCD interface (supporting 4-wire touchscreen)
 - A VGA interface
 - A HDMI interface
 - A MIC Input
 - Audio Headphone Output

- **Other Interfaces & Buttons**

- A Power Jack (12V round DC power jack)
- A Power Reset Button, A System ResetButton, A BOOTButton and 2 Buttons by customs.
- A RTC

1.2 Interfaces & Buttons

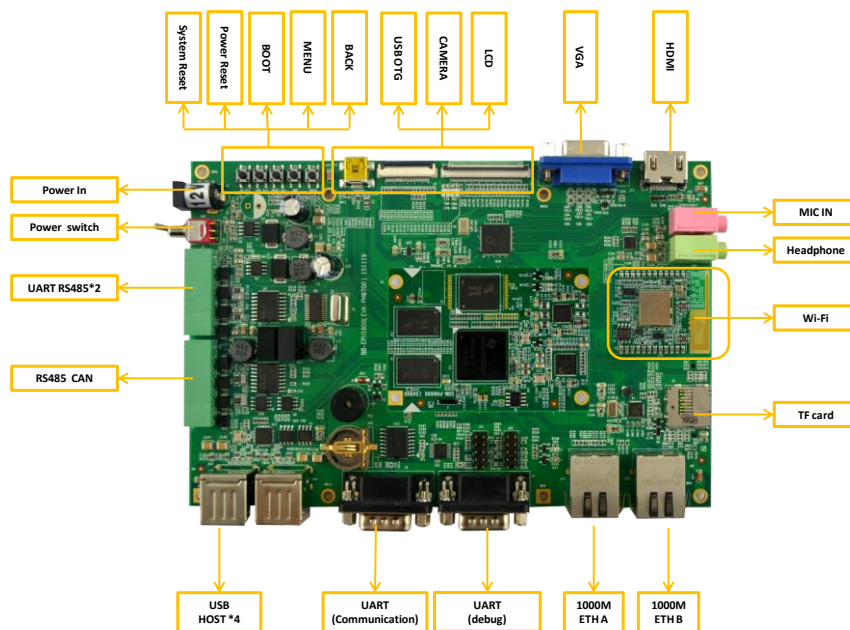

Attention: the Uart(Communication) and the Uart (output from the Green Jack)share the same uart ,Don't use them at the same time.

Figure 1 Interfaces&Buttons

1.3 System Block Diagram

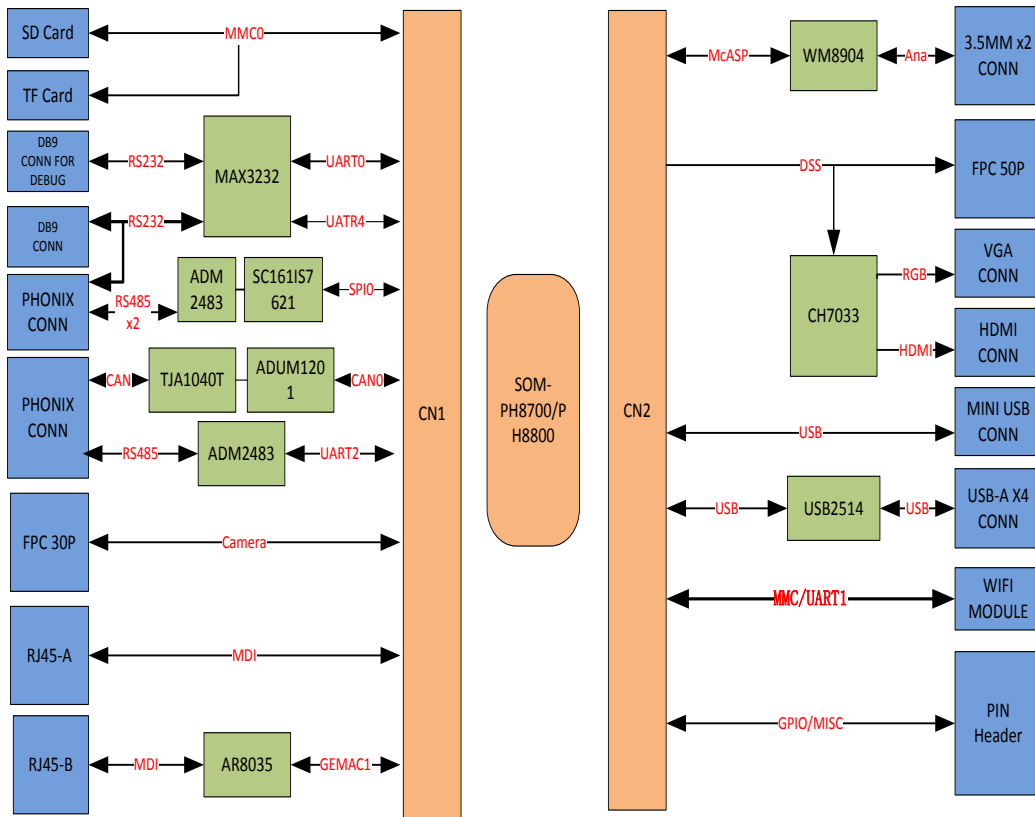

Figure 2 BB-EPH1800 System Block Diagram

1.4 Product Dimensions(mm)

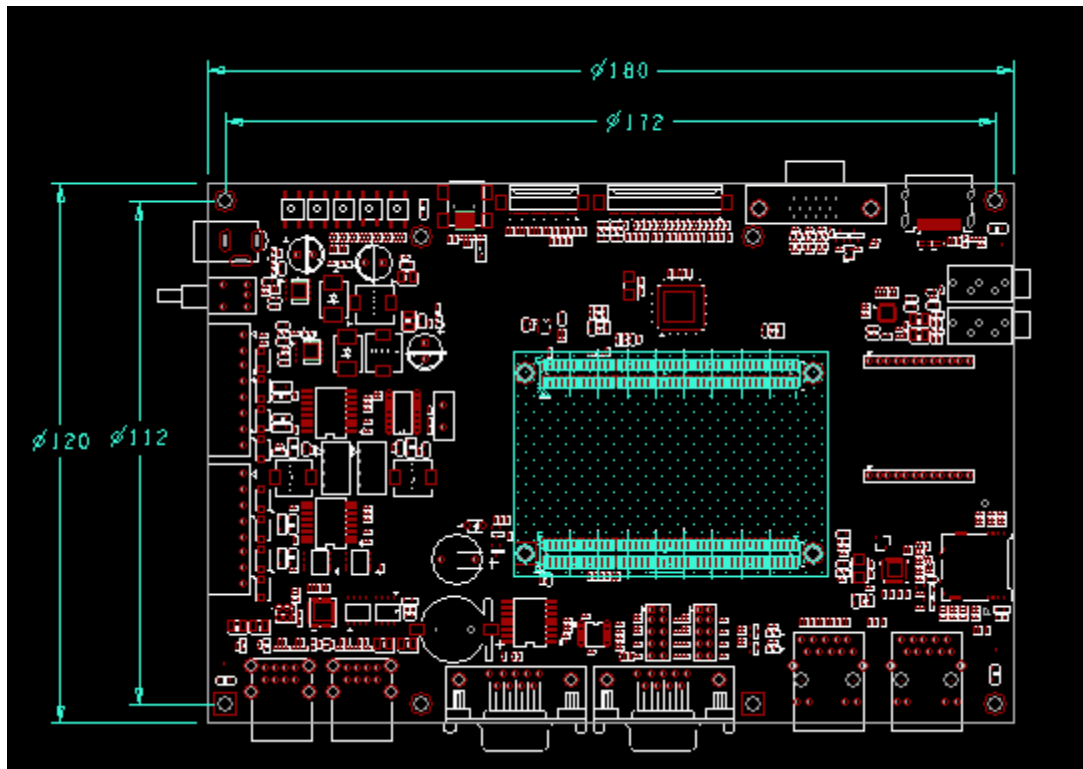

Figure 3 Product Dimensions

Chapter 2

Introduction to Hardware System

This chapter will introduce in detail the structure, expansion and peripheral interfaces of BB-EPH1800 hardware system.

◦

2.1 Overview of CPU

BB-EPH1800 is the base board for SOM-PH8700/PH8800 Designed by Embest. That make a whole show of the AM335X/AM437X Soc feature, The customs can free replace each other with SOM-PH8700/PH8800 , Provide a perfect solution for the resource extension.

◦

2.2 Introduction to Peripheral Chips

2.2.1 CH7033

CH7033B is a video encoder designed to drive high-resolution displays through HDMI, DVI, YPbPr and VGA interfaces. It is suited for mobile Internet devices, laptops, tablet computers, portable e-books and smart phones.

This chip possesses advanced scaling engine that supports 1080P HDTV. The integrated frequency shifting engine can provide 60fps under 1080p mode. Additionally, CH7033B supports SPDIF and IIS digital audio input.

2.2.2 AR8035

AR8035 is a low-power and low-cost Ethernet PHY chip and integrated with a 10/100/1000Mb transceiver. It is a single-port tri-speed Ethernet PHY and supports MAC.TM RGMII interfaces.

AR8035 is compliant with the IEEE 802.3az Energy Efficiency Ethernet Standard and the Atheros’s proprietary SmartEEE standard, which allows traditional MAC/SoC devices incompatible with 802.3az to function as a complete 802.3az system.

2.3 Details of Interfaces

This section will introduce in detail the constructions, principles, interface definitions and considerations of use of peripherals , so that users may have a deep understanding of the hardware circuitry of the board.

2.3.1 PH180 Interfaces

BB-EPH1800 connect with the core board with the PH180 Interfaces defined by Embest.

P1, P2 interfaces defined as below

PIN-OUT for P2

Pin	Signal Name	Function		Signal Description	Pin
1	VRTC	PWR	CTL	PWRON_RESETn	2
3	MMCO_DAT0	SD/MMC		WARM_RESETn	4
5	MMCO_DAT1		MMCO_CMD	6	
7	MMCO_DAT2		MMCO_CD	8	
9	MMCO_DAT3		MMCO_CLK	10	
11	GND1	GND		SPIO_CS0	12

13	SPIO_SCLK	SPI		SPIO_D1	14
15	SPIO_D0			UART2_RXD	16
17	UART0_RXD	UART		UART2_TXD	18
19	UART0_TXD			UART2_RTS	20
21	UART3_RXD			UART2_CTS	22
23	UART3_TXD			UART1_RXD	24
25	CAN0_RX	CAN		UART1_TXD	26
27	CAN0_TX			UART1_RTS	28
29	I2C0_SDA	I2C		GND	UART1_CTS
31	I2C0_SCL		GND3		32
33	GND2	GND		CAM_D1	34
35	CAM_D0	CSI		CAM_D3	36
37	CAM_D2			CAM_D5	38
39	CAM_D4			CAM_D7	40
41	CAM_D6			CAM_D9	42
43	CAM_D8			CAM_D10	44
45	GND4	GND		CAM_D11	46
47	CAM_FIELD		GND	GND5	48
49	CAM_WEN			CAM_PCLK	50
51	GBE_GREEN		GND	GND6	52
53	GBE_YELLOW			CAM_HD	54
55	GND8	GND		CAM_VD	56
57	GBE_TRP2	ETH	GND	GND7	58
59	GBE_TRN2		GBE_TRP0	60	
61	GBE_TRP3		GBE_TRN0	62	
63	GBE_TRN3		GBE_TRP1	64	
65	GND9	GND		GBE_TRN1	66
67	USB0_DM		GND	GND10	68
69	USB0_DP			GBE_MDC	70
71	GND11	GND		GBE_MDIO	72
73	USB1_DM	USB		USB0_ID	74
75	USB1_DP			USB0_VBUS	76
77	GND12	GND		USB1_VBUS	78
79	SPI1_SCLK	SPI	CTL	LCD_PWM	80
81	SPI1_D0			BOOT0_SEL	82
83	SPI1_D1			BOOT1_SEL	84
85	SPI1_CS0			BOOT2_SEL	86
87	GND13	GND		GND14	88
89	5V_VDD1	PWR		5V_VDD2	90

PIN-OUT for P1

Pin	Signal Name	Function	Signal Name	Pin
1	WAKE_UP	CTL	PWR_GOOD	2

3	MCASPO_AHCLKX			RESET_OUTn	4
5	MCASPO_FSX			MCASPO_ACLKX	6
7	MCASPO_AHCLKR	I2S		MCASPO_ACLKR	8
9	MCASPO_FSR			MCASPO_AXR0	10
11	VDDA_ADC			MCASPO_AXR1	12
13	ADC0	ADC		ADC1	14
15	ADC2			ADC3	16
17	GNDA_ADC			HDMI_CEC/ADC4	18
19	HDMI_HPD/ADC5			HDMI_TX2-/ADC6	20
21	HDMI_DSCL/IO1			HDMI_TX2+/ADC7	22
23	HDMI_DSDA/IO2		GND	GND2	24
25	HDMI_TX1-/IO3	HDMI/GPIO		HDMI_TXC-/IO7	26
27	HDMI_TX1+/IO4			HDMI_TXC+/IO8	28
29	HDMI_TX0-/IO5		GND	GND3	30
31	HDMI_TX0+/IO6			LCD_D11	32
33	GND4	GND		LCD_D12	34
35	LCD_D0			LCD_D13	36
37	LCD_D1			LCD_D14	38
39	LCD_D2			LCD_D15	40
41	LCD_D3		GND	GND6	42
43	LCD_D4			LCD_DE	44
45	LCD_D5			LCD_D16	46
47	LCD_D6			LCD_D17	48
49	LCD_D7			LCD_D18	50
51	LCD_D8	LCD		LCD_D19	52
53	LCD_D9			LCD_D20	54
55	LCD_D10			LCD_D21	56
57	LCD_HSYNC			LCD_D22	58
59	LCD_VSYNC			LCD_D23	60
61	GND5	GND	CAN	CAN1_RX	62
63	LCD_PCLK			CAN1_TX	64
65	GND7	GND	I2C	I2C_SCL	66
67	IO1/ETH_TXEN			I2C_SDA	68
69	IO2/ETH_RXDV			IO3/ETH_TXD3	70
71	IO4/ETH_TXD2			IO5/ETH_TXD1	72
73	IO6/ETH_TXD0	GPIO/ETH		IO7/ETH_TXCK	74
75	IO8/ETH_RXCK			IO9/ETH_RXD3	76
77	IO10/ETH_RXD2			IO11/ETH_RXD1	78
79	IO12/ETH_RXD0			RVD1/MMC2_CLK	80
81	RVD2/MMC2_CMD			RVD3/MMC2_D0	82
83	RVD4/MMC2_D1	RVD/MMC		RVD5/MMC2_D2	84
85	RVD6/MMC2_D3			RVD7/MMC2_D4	86
87	RVD5/MMC2_D5			RVD9/MMC2_D6	88

89	GND8	GND	GND9	90
----	------	-----	------	----

P1, P2 Signal Description as below

P2 For BB-EPH1800	Pin	Signal Name	INPUT/OUTPUT	ACTIVE H/L	Power level	Description
	1	VRTC	O		3.3V	POWER 3.3V
	2	PWRON_RESE Tn	O	L	3.3V	POWER_RESET
	3	MMC0_DAT0	I/O		3.3V	MMC0
	4	WARM_RESET n	O	L	3.3V	RESET
	5	MMC0_DAT1	I/O		3.3V	MMC0
	6	MMC0_CMD	I		3.3V	MMC0
	7	MMC0_DAT2	I/O		3.3V	MMC0
	8	MMC0_CD	O		3.3V	MMC0
	9	MMC0_DAT3	I/O		3.3V	MMC0
	10	MMC0_CLK	I		3.3V	MMC0
	11	GND1	G		0V	GND
	12	SPI0_CS0	I		3.3V	SPI0
	13	SPI0_SCLK	I		3.3V	SPI0
	14	SPI0_D1	O		3.3V	SPI0
	15	SPI0_D0	I		3.3V	SPI0
	16	UART2_RXD	I		3.3V	UART2
	17	UART0_RXD	O		3.3V	UART0
	18	UART2_TXD	O		3.3V	UART2
	19	UART0_TXD	I		3.3V	UART0
	20	UART2_RTS	I		3.3V	UART2
	21	UART3_RXD	O		3.3V	UART3
	22	UART2_CTS	O		3.3V	UART2
	23	UART3_TXD	I		3.3V	UART3
	24	UART1_RXD	I		3.3V	UART1
	25	CAN0_RX	O		3.3V	CAN0_UART
	26	UART1_TXD	O		3.3V	UART1
	27	CAN0_TX	I		3.3V	CAN0_UART
	28	UART1_RTS	I		3.3V	UART1
	29	I2C0_SDA	I/O		3.3V	I2C0

30	UART1_CTS	O		3.3V	UART1
31	I2C0_SCL	I		3.3V	I2C0
32	GND3	G		0V	GND
33	GND2	G		0V	GND
34	CAM_D1	O		3.3V	CAM
35	CAM_D0	I		3.3V	CAM
36	CAM_D3	O		3.3V	CAM
37	CAM_D2	I		3.3V	CAM
38	CAM_D5	O		3.3V	CAM
39	CAM_D4	I		3.3V	CAM
40	CAM_D7	O		3.3V	CAM
41	CAM_D6	I		3.3V	CAM
42	CAM_D9	O		3.3V	CAM
43	CAM_D8	I		3.3V	CAM
44	CAM_D10	O		3.3V	CAM
45	GND4	G		0V	GND
46	CAM_D11	O		3.3V	CAM
47	CAM_FIELD	O		3.3V	CAM
48	GND5	G		0V	CAM
49	CAM_WEN	O		3.3V	CAM
50	CAM_PCLK	O		3.3V	CAM
51	GBE_GREEN	I	L	3.3V	MIIA_LED_LINK
52	GND6	G		0V	GND
53	GBE_YELLOW	I	L	3.3V	MIIA_LED_ACT
54	CAM_HD	O		3.3V	CAM
55	GND8	G		0V	GND
56	CAM_VD	O		3.3V	CAM
57	GBE_TRP2	O			GBE Data
58	GND7	G		0V	GND
59	GBE_TRN2	O			GBE Data
60	GBE_TRP0	I			GBE Data
61	GBE_TRP3	O			GBE Data
62	GBE_TRN0	I			GBE Data
63	GBE_TRN3	O			GBE Data
64	GBE_TRP1	I			GBE Data
65	GND9	G		0V	GND
66	GBE_TRN1	I			GBE Data
67	USB0_DM				USB0
68	GND10	G		0V	GND
69	USB0_DP				USB0
70	GBE_MDC	I		3.3V	MDIO Clk
71	GND11	G		0V	GND
72	GBE_MDIO	I/O		3.3V	MDIO DATA

73	USB1_DM				USB1
74	USB0_ID	O			USB0
75	USB1_DP				USB1
76	USB0_VBUS	I		5V	POWER 5V for USB0
77	GND12	G		0V	GND
78	USB1_VBUS	I		5V	POWER 5V for USB0
79	SPI1_SCLK	I		3.3V	SPI1
80	LCD_PWM	I		3.3V	PWM for LCD
81	SPI1_D0	I		3.3V	SPI1
82	BOOT0_SEL	O		3.3V	BOOT0
83	SPI1_D1	O		3.3V	SPI1
84	BOOT1_SEL	O		3.3V	BOOT1
85	SPI1_CS0	I		3.3V	SPI1
86	BOOT2_SEL	O		3.3V	BOOT2
87	GND13	G		0V	GND
88	GND14	G		0V	GND
89	5V_VDD1	O		5V	POWER 5v for core board
90	5V_VDD2	O		5V	POWER 5v for core board
P1 For BB- EPH18 00					
Pin	Signal Name	INPUT/OUTPUT	ACTIVE H/L	Power level	Description
1	WAKE_UP	O		1.8V	NC
2	PWR_GOOD	I	H	3.3V	Core board power good
3	MCASP0_AHCLKX	I		3.3V	I2S_mclk
4	RESET_OUTn	I	L	3.3V	RESET
5	MCASP0_FSX	I		3.3V	I2S_LRCLK
6	MCASP0_ACLKX	I		3.3V	I2S_BCLK
7	MCASP0_AHCLKR	O		3.3V	I2S_mclk
8	MCASP0_ACLKR	O		3.3V	I2S_BCLK

9	MCASP0_FSR	O		3.3V	I2S_LRCLK
10	MCASP0_AXR0	I/O		3.3V	I2S_DATA0
11	VDDA_ADC	I		1.8V	1.8V_ADC
12	MCASP0_AXR1	I/O		3.3V	I2S_DATA1
13	ADC0	O		1.8V	TOUCH SCREEN X+
14	ADC1	O		1.8V	TOUCH SCREEN X-
15	ADC2	O		1.8V	TOUCH SCREEN Y+
16	ADC3	O		1.8V	TOUCH SCREEN Y-
17	GND_A_ADC	G		0V	GND
18	HDMI_CEC/AD C4	O		1.8V	NC
19	HDMI_HPD/AD C5	O		1.8V	NC
20	HDMI_TX2-/AD C6	O	L	1.8V	KEY_MENU
21	HDMI_DSCL/IO 1	O	L	3.3V	IO_SPI0_IRQ
22	HDMI_TX2+/AD C7	O	L	1.8V	KEY_BACK
23	HDMI_DSDA/IO 2	I	L	3.3V	IO_RTC_INTn
24	GND2	GND		0V	GND
25	HDMI_TX1-/IO3	O	H	3.3V	IO_CH7033_HPD(rev)
26	HDMI_TXC-/IO 7	O		3.3V	IO_CAM_CLK(CAM_CLK)
27	HDMI_TX1+/IO 4	O	L	3.3V	IO_ETH2_INT
28	HDMI_TXC+/IO 8	I		3.3V	IO_CAM_STROBE(MMC0 _WP)
29	HDMI_TX0-/IO5	O	L	3.3V	IO_I2S_INT
30	GND3	O		0V	GND
31	HDMI_TX0+/IO 6	I	H	3.3V	IO_BEEP
32	LCD_D11	I		3.3V	LCD
33	GND4	G		0V	GND
34	LCD_D12	I		3.3V	LCD
35	LCD_D0	I		3.3V	LCD
36	LCD_D13	I		3.3V	LCD
37	LCD_D1	I		3.3V	LCD
38	LCD_D14	I		3.3V	LCD
39	LCD_D2	I		3.3V	LCD
40	LCD_D15	I		3.3V	LCD

41	LCD_D3	I		3.3V	LCD
42	GND6	G		0V	GND
43	LCD_D4	I		3.3V	LCD
44	LCD_DE	I		3.3V	LCD
45	LCD_D5	I		3.3V	LCD
46	LCD_D16	I		3.3V	LCD
47	LCD_D6	I		3.3V	LCD
48	LCD_D17	I		3.3V	LCD
49	LCD_D7	I		3.3V	LCD
50	LCD_D18	I		3.3V	LCD
51	LCD_D8	I		3.3V	LCD
52	LCD_D19	I		3.3V	LCD
53	LCD_D9	I		3.3V	LCD
54	LCD_D20	I		3.3V	LCD
55	LCD_D10	I		3.3V	LCD
56	LCD_D21	I		3.3V	LCD
57	LCD_HSYNC	I		3.3V	LCD
58	LCD_D22	I		3.3V	LCD
59	LCD_VSYNC	I		3.3V	LCD
60	LCD_D23	I		3.3V	LCD
61	GND5	O		0V	GND
62	CAN1_RX	O		3.3V	CAN1_UART
63	LCD_PCLK	I		3.3V	LCD
64	CAN1_TX	O		3.3V	CAN1_UART
65	GND7	G		0V	GND
66	I2C_SCL	I		3.3V	I2C1
67	IO1/ETH_TXEN	I		3.3V	ETH
68	I2C_SDA	G		3.3V	I2C1
69	IO2/ETH_RXDV	O		3.3V	ETH
70	IO3/ETH_TXD3	I		3.3V	ETH
71	IO4/ETH_TXD2	I		3.3V	ETH
72	IO5/ETH_TXD1	I		3.3V	ETH
73	IO6/ETH_TXD0	I		3.3V	ETH
74	IO7/ETH_TXCK	I		3.3V	ETH
75	IO8/ETH_RXCK	O		3.3V	ETH
76	IO9/ETH_RXD3	O		3.3V	ETH
77	IO10/ETH_RXD 2	O		3.3V	ETH
78	IO11/ETH_RXD 1	O		3.3V	ETH
79	IO12/ETH_RXD 0	O		3.3V	ETH
80	RVD1/MMC2_C	I		3.3V	MMC1

	LK				
81	RVD2/MMC2_C MD	I		3.3V	MMC1
82	RVD3/MMC2_D 0	I/O		3.3V	MMC1
83	RVD4/MMC2_D 1	I/O		3.3V	MMC1
84	RVD5/MMC2_D 2	I/O		3.3V	MMC1
85	RVD6/MMC2_D 3	I/O		3.3V	MMC1
86	RVD7/MMC2_D 4	I/O		3.3V	MMC1
87	RVD5/MMC2_D 5	I/O		3.3V	MMC1
88	RVD9/MMC2_D 6	I/O		3.3V	MMC1
89	GND8	G		0V	GND
90	GND9	G		0V	GND

2.3.2 LCD/VGA/HDMI

The powerful video performance is one of the important features of BB-EPH1800. It supports multiple types of displays including 50-pin medium-/small-sized LCD modules, VGA/HDMI monitors. LCD/VGA/HDMI shares the same video data source. Now let's take a deep look at the hardware implementation of the display function of LCD/VGA/HDMI interfaces.

- **LCD**

The LCD interface (J9) of BB-EPH1800 is implemented with a 50-pin FPC connector which connects LCD module to the board. Currently LCD8000-43T (4.3 inch), LCD8000-70T (7 inch) and VGA8000 conversion module are supported by the board. The following table contains pin definitions of LCD interface (including the fixed pins of the connector).

chart 1 LCD Display

LCD Display: J9			
Pin	Signal Description	Device	Signal Type
1	DSS_D0		Data Blue
2	DSS_D1		
3	DSS_D2		
4	DSS_D3		
5	DSS_D4		
6	DSS_D5		
7	DSS_D6		
8	DSS_D7		
9	GND		Ground
10	DSS_D8		Data Green
11	DSS_D9		
12	DSS_D10		
13	DSS_D11		
14	DSS_D12		
15	DSS_D13		
16	DSS_D14		
17	DSS_D15		
18	GND		Ground
19	DSS_D16		Data Red
20	DSS_D17		
21	DSS_D18		
22	DSS_D19		
23	DSS_D20		
24	DSS_D21		
25	DSS_D22		
26	DSS_D23		
27	GND		Ground
28	DSS_DEN		Data Sync
29	DSS_HSYNC		
30	DSS_VSYNC		
31	GND		Ground
32	DSS_PCLK		Clock
33	GND		Ground
34	TOUCH_X+		Touch Panel
35	TOUCH_X-		
36	TOUCH_Y+		
37	TOUCH_Y-		
38	SPI0_CLK		SPI
39	SPI0_MOSI		
40	SPI0_MISO		

LCD Display: J9			
41	SPI0_CS _n		
42	LCD_I2C_SCL		I2C
43	LCD_I2C_SDA		
44	GND		Ground
45	3.3V_LCD_VDD		Power 3.3V
46	3.3V_LCD_VDD		
47	5V_LCD_VDD		Power 5V
48	5V_LCD_VDD		
49	LCD_RESE _{Tn}		Reset
50	LCD_PWM		Control
51	GND		Ground
52	GND		

- **VGA**

The VGA interface (J11) is realized by using a standard D-SUB 15-pin connector. The following table contains pin definitions of J11.

chart 2 VGA Display

VGA Display: J11			
Pin	Signal Description	Device	Signal Type
1	VGA_REG	CH7033B	Data
2	VGA_G _{RN}		
3	VGA_B _{LU}		
4	ID2/REV		Other
5	GND		Ground
6	GND		
7	GND		
8	GND		
9	VGA_VDD		Power 5V
10	GND		Ground
11	ID0/REV		Other
12	I2C_SDA_VGA		I2C
13	5V_HSYNC		SYNC
14	5V_VSYNC		SYNC
15	I2C_SCL_VGA		I2C

- **HDMI**

The HDMI interface on BB-EPH1800 is named as J12, which is a standard

19-pin HDMI connector. The following table contains pin definitions of the interface (including the fixed pins of the connector).

chart 3 HDMI Display

HDMI Display: J12			
Pin	Signal Name	Device	Signal Type
1	HDMI_TX2+	CH7033B	Differential Data & Clock, GND as reference for signal
2	GND	CH7033B	
3	HDMI_TX2-	CH7033B	
4	HDMI_TX1+	CH7033B	
5	GND	CH7033B	
6	HDMI_TX1-	CH7033B	
7	HDMI_TX0+	CH7033B	
8	GND	CH7033B	
9	HDMI_TX0-	CH7033B	
10	HDMI_CLK+	CH7033B	
11	GND	CH7033B	
12	HDMI_CLK-	CH7033B	
13	NC		Other
14	NC		
15	HDMICONN_I2CSCL	CH7033B	I2C
16	HDMICONN_I2CSDA	CH7033B	
17	GND		Ground Power 5V
18	5V_VDD		
19	HDMICONN_HPLG		Status
20	GND_SHELDS		Ground
21	GND_SHELDS		
22	GND_SHELDS		
23	GND_SHELDS		

2.3.3 CAMERA

The 30-pin FPC connector (J8) on BB-EPH1800 is used to support 12-bit input of digital cameras. The following table contains pin definitions of the FPC connector;

chart 4 CAMERA

Camera(J8)			
Pin	Signal description	Device	Signal Type
1	GND		Ground
2	CAM_D0		Data
3	CAM_D1		
4	CAM_D2		
5	CAM_D3		
6	CAM_D4		
7	CAM_D5		
8	CAM_D6		
9	CAM_D7		
10	CAM_D8		
11	CAM_D9		
12	CAM_D10		
13	CAM_D11		
14	GND		Ground
15	PCLK		Clock
16	GND		Ground
17	CAM_HS		SYNC
18	VDD_5V		Power 5V
19	CAM_VS		SYNC
20	3.3V_CAMERA		Power 3.3V
21	CAM_CLK		Clock
22	CAM_CLK1		
23	GND		Ground
24	CAM_FLD		Status
25	CAM_WEN		
26	CAM_STROBE		
27	CAM_SDA		I2C
28	CAM_SCL		
29	GND		Ground
30	VDDIO		Power for IO
31	GND		Power
32	GND		

2.3.4 Gigabit Ethernet

BB-EPH1800 can provide two relatively high network performance of gigabit Ethernet. A Ethernet is implemented by utilizing part of the EMAC controller integrated in Core Board and the PHY AR8035 on core board. The other AR8035 is added on BB-EPH1800

to realize connections between RG45 and EMAC. The RJ-45 interface is named as J16/J17 to provide connection to network devices.

- **RJ-45**

The following table contains pin definitions of RJ-45 (J14) Ethernet interface;

chart 5 Ethernet Interface

RJ45 Ethernet: J16/J17			
Pin	Signal Description	Device	Signal Type
1	MIIA_TRP0	AR8035	Data
2	MIIA_TRN0		
3	MIIA_TRP1		
4	MIIA_TRN1		
5	NC		Shield
6	NC		
7	MIIA_TRP2	AR8035	Data
8	MIIA_TRN2		
9	MIIA_TRP3		
10	MIIA_TRN3		
11	MIIA_LED_LINK/ Pull-up	LED Control	LED
12	Pull-down/ MIIA_LED_LINK		
13	MIIA_LED_ACT		
14	Pull-up		
15	GND		GND
16	GND		
17	NC		Fix
18	NC		

2.3.5 TF Card

TF card are used to provide solid storage of boot code and system. MMC Interface

- **TF card Interface**

The following table contains pin definitions of TF Card interface

chart 6 TF Card Interface

TF card connector: J2			
Pin	Signal Description	Device	Signal Type
1	MMC_DAT2		Data
2	MMC_DAT3		
3	MMC_CMD		Command
4	3.3V_VDD		Power 3.3V
5	MMC_CLK		Clock
6	GND		Ground
7	MMC_DAT0		Data
8	MMC_DAT1		
9	GND		Ground
10	MMC_CD		Command
11	GND		
12	GND		
13	GND		
14	NC		Fixed
15	NC		

2.3.6 USB & HUB

To satisfy diverse applications involving USB interfaces, BB-EPH1800 provides 4 USB ports. However, there are only 2 USB controllers in HPS, one is used to USB OTG .thus a PHY and a HUB are added to ensure 4 USB port can work at the same time. The USB2514B is used to expand the ports of PHY. The following contents will introduce the implementation of USB in detail.

chart 7 USB Interface

USB Connector: J14/J15			
Pin	Signal Description	Device	Signal Type
1	VBUS1		USB1
2	DN1	USB2514B	
3	DP1	USB2514B	
4	GND		USB2
5	VBUS2		
6	DN2	USB2514B	
7	DP2	USB2514B	USB2
8	GND		
9	GND_SHIELDS		FIX

USB Connector: J14/J15		
10	GND_SHIELDS	
11	GND_SHIELDS	
12	GND_SHIELDS	

2.3.7 Wifi

J24, J25 are reserved to support the EXP-WFB00 (Wifi module) designed by Embest.

The following table contains pin definitions of WiFi interface

J24 chart 8

Pin	Signal Description	Signal Type
1	BT_CTS_3V3	Cts from WIFI
2	BT_TXD_3V3	TXD from WIFI
3	BT_RTS_3V3	RTS from WIFI
4	BT_RXD_3V3	RXD from WIFI
5	3V3_WIF	3.3V power
6	BT_AUD_FS_3V3	I2S
7	WLAN_EN_3V3	GPIO
8	BT_AUD_IN_3V3	I2S
9	WL_IRQ_3V3	GPIO
10	BT_AUD_OUT_3V3	I2S
11	GND	GND
12	BT_AUD_CLK_3V3	I2S

J25 chart 9

Pin	Signal Description	Signal Type
1	WL_SDIO_CLK_3V3	MMC
2	GND	GND
3	WL_SDIO_D0_3V3	MMC
4	WL_SDIO_D1_3V3	MMC
5	WL_SDIO_D2_3V3	MMC
6	WL_SDIO_D3_3V3	MMC
7	WL_SDIO_CMD_3V3	MMC
8	5V_WIFI	5V power
9	I2C_WIFI_SCL	I2c
10	Wifi_RESETh	reset
11	I2C_WIFI_SDA	I2c
12	BT_EN_3V3	GPIO

2.3.8 UART&RS485&CAN

J6,J7 of BB-EPH1800 are UART&RS485&CAN Interfaces, The following table contains pin definitions of UART&RS485&CAN

J6 chart 10

Pin	Signal Description	Signal Type
1	TXD	UART (shared by J5)
2	RXD	UART (shared by J5)
3	GND	GND
4	RS485_A3	RS485+
5	RS485_B3	RS485-
6	GND_ISO	GND for RS485/CAN
7	RS485_A2	RS485+
8	RS485_B2	RS485-

J7 chart 11

Pin	Signal Description	Signal Type
1	12V_EXT	External 12V input
2	GND	
3	GND	
4	RS485_A1	RS485+
5	RS485_B1	RS485-
6	GND_ISO	GND for RS485/CAN
7	CANL1	CAN
8	CANH1	CAN

2.3.9 Button

There are 6 buttons on BB-EPH1800. S1 button can reset the system. S2 button can reset the power of the core board .S3 button can set where the board boot from. The rest of the two buttons can be programmed by users.

2.3.10 UART

J4 and J5 are two RS232 level connectors specially provided on BB-EPH1800. J4 is used to connect RS232 serial debuggers and the PC, J5 is defined by the customs to do the

communication.

2.3.11 LED

The LEDs on BB-EPH1800 can be used to indicate board status.

The following table contains the LEDs function define.

chart 12 LED

LED Ref	Signal Name	LED Function
D5		Bright indicate 12V good
D6		Bright indicate 5V good
D7		Bright indicate 3.3V good
D60		Bright indicate core board power good
D53		CAN communication indication
D57		CAN communication indication

2.3.12 RTC

There is a RTC circuitry on BB-EPH1800. When a battery is inserted in J10, the board can keep a proper clock after power supply is turned off. A CR1220 battery and a DS3221 chip are involved in the implementation of RTC circuitry. Please refer to schematics and datasheet for its working principle and detailed circuit.

2.3.13 External Button

To facilitate users' function expansion, part of resources of core board has been extended by using two 10-pin connectors. Please refer to schematics and datasheet for its detailed circuit.

Attention: some resource on extend interface has been used , don't use them again.

Technical Support and Warranty

Technical Support



Embest Technology provides its product with one-year free technical support including:

- Providing software and hardware resources related to the embedded products of Embest Technology;
- Helping customers properly compile and run the source code provided by Embest Technology;
- Providing technical support service if the embedded hardware products do not function properly under the circumstances that customers operate according to the instructions in the documents provided by Embest Technology;
- Helping customers troubleshoot the products.



The following conditions will not be covered by our technical support service. We will take appropriate measures accordingly:

- Customers encounter issues related to software or hardware during their development process;
- Customers encounter issues caused by any unauthorized alter to the embedded operating system;
- Customers encounter issues related to their own applications;
- Customers encounter issues caused by any unauthorized alter to the source code provided by Embest Technology;

Warranty Conditions

- 1) 12-month free warranty on the PCB under normal conditions of use since the sales of the product;
- 2) The following conditions are not covered by free services; Embest Technology will charge accordingly:
 - Customers fail to provide valid purchase vouchers or the product identification tag is damaged, unreadable, altered or inconsistent with the products.
 - Products are damaged caused by operations inconsistent with the user manual;
 - Products are damaged in appearance or function caused by natural disasters (flood, fire, earthquake, lightning strike or typhoon) or natural aging of components or other force majeure;
 - Products are damaged in appearance or function caused by power failure, external forces, water, animals or foreign materials;
 - Products malfunction caused by disassembly or alter of components by customers or, products disassembled or repaired by persons or organizations unauthorized by Embest Technology, or altered in factory specifications, or configured or expanded with the components that are not provided or recognized by Embest Technology and the resulted damage in appearance or function;
 - Product failures caused by the software or system installed by customers or inappropriate settings of software or computer viruses;
 - Products purchased from unauthorized sales;
 - Warranty (including verbal and written) that is not made by Embest Technology and not included in the scope of our warranty should be fulfilled by the party who committed. Embest Technology has no any responsibility;
- 3) Within the period of warranty, the freight for sending products from customers to Embest Technology should be paid by customers; the freight from Embest to customers should be paid by us. The freight in any direction occurs after warranty period should be paid by customers.
- 4) Please contact technical support if there is any repair request.

Note:

 Embest Technology will not take any responsibility on the products sent back without the permission of the company.

Contact Information

Technical Support

Tel: +86-755-25635626-872/875/897

Email: support@embest-tech.com

Maillist: <http://lists.rocketboards.org/cgi-bin/mailman/listinfo/rfi>

Sales Information

Tel: +86-755-25635626-863/865/866/867/868

Fax: +86-755-25616057

Email: globalsales@embest-tech.com

Company Information

Website: <http://www.embest-tech.com>

Address: Tower B 4/F, Shanshui Building, Nanshan Yungu Innovation Industry Park,
Liuxian Ave. No. 1183, Nanshan District, Shenzhen, Guangdong, China (518055)