



MICROCHIP

**RNXV Evaluation Kit
User's Guide**

Note the following details of the code protection feature on Microchip devices:

- Microchip products meet the specification contained in their particular Microchip Data Sheet.
- Microchip believes that its family of products is one of the most secure families of its kind on the market today, when used in the intended manner and under normal conditions.
- There are dishonest and possibly illegal methods used to breach the code protection feature. All of these methods, to our knowledge, require using the Microchip products in a manner outside the operating specifications contained in Microchip's Data Sheets. Most likely, the person doing so is engaged in theft of intellectual property.
- Microchip is willing to work with the customer who is concerned about the integrity of their code.
- Neither Microchip nor any other semiconductor manufacturer can guarantee the security of their code. Code protection does not mean that we are guaranteeing the product as "unbreakable."

Code protection is constantly evolving. We at Microchip are committed to continuously improving the code protection features of our products. Attempts to break Microchip's code protection feature may be a violation of the Digital Millennium Copyright Act. If such acts allow unauthorized access to your software or other copyrighted work, you may have a right to sue for relief under that Act.

Information contained in this publication regarding device applications and the like is provided only for your convenience and may be superseded by updates. It is your responsibility to ensure that your application meets with your specifications. MICROCHIP MAKES NO REPRESENTATIONS OR WARRANTIES OF ANY KIND WHETHER EXPRESS OR IMPLIED, WRITTEN OR ORAL, STATUTORY OR OTHERWISE, RELATED TO THE INFORMATION, INCLUDING BUT NOT LIMITED TO ITS CONDITION, QUALITY, PERFORMANCE, MERCHANTABILITY OR FITNESS FOR PURPOSE. Microchip disclaims all liability arising from this information and its use. Use of Microchip devices in life support and/or safety applications is entirely at the buyer's risk, and the buyer agrees to defend, indemnify and hold harmless Microchip from any and all damages, claims, suits, or expenses resulting from such use. No licenses are conveyed, implicitly or otherwise, under any Microchip intellectual property rights.

Trademarks

The Microchip name and logo, the Microchip logo, dsPIC, FlashFlex, KEELOQ, KEELOQ logo, MPLAB, PIC, PICmicro, PICSTART, PIC³² logo, rPIC, SST, SST Logo, SuperFlash and UNI/O are registered trademarks of Microchip Technology Incorporated in the U.S.A. and other countries.

FilterLab, Hampshire, HI-TECH C, Linear Active Thermistor, MTP, SEEVAL and The Embedded Control Solutions Company are registered trademarks of Microchip Technology Incorporated in the U.S.A.

Silicon Storage Technology is a registered trademark of Microchip Technology Inc. in other countries.

Analog-for-the-Digital Age, Application Maestro, BodyCom, chipKIT, chipKIT logo, CodeGuard, dsPICDEM, dsPICDEM.net, dsPICworks, dsSPEAK, ECAN, ECONOMONITOR, FanSense, HI-TIDE, In-Circuit Serial Programming, ICSP, Mindi, MiWi, MPASM, MPF, MPLAB Certified logo, MPLIB, MPLINK, mTouch, Omniscient Code Generation, PICC, PICC-18, PICDEM, PICDEM.net, PICkit, PICtail, REAL ICE, rLAB, Select Mode, SQI, Serial Quad I/O, Total Endurance, TSHARC, UniWinDriver, WiperLock, ZENA and Z-Scale are trademarks of Microchip Technology Incorporated in the U.S.A. and other countries.

SQTP is a service mark of Microchip Technology Incorporated in the U.S.A.

GestIC and ULPP are registered trademarks of Microchip Technology Germany II GmbH & Co. & KG, a subsidiary of Microchip Technology Inc., in other countries.

All other trademarks mentioned herein are property of their respective companies.

© 2013, Microchip Technology Incorporated, Printed in the U.S.A., All Rights Reserved.

 Printed on recycled paper.

ISBN: 978-1-62077-691-9

**QUALITY MANAGEMENT SYSTEM
CERTIFIED BY DNV
= ISO/TS 16949 =**

Microchip received ISO/TS-16949:2009 certification for its worldwide headquarters, design and wafer fabrication facilities in Chandler and Tempe, Arizona; Gresham, Oregon and design centers in California and India. The Company's quality system processes and procedures are for its PIC[®] MCUs and dsPIC[®] DSCs, KEELOQ[®] code hopping devices, Serial EEPROMs, microperipherals, nonvolatile memory and analog products. In addition, Microchip's quality system for the design and manufacture of development systems is ISO 9001:2000 certified.

Object of Declaration: RNXV Evaluation Kit

EU Declaration of Conformity

This declaration of conformity is issued by the manufacturer.

The development/evaluation tool is designed to be used for research and development in a laboratory environment. This development/evaluation tool is not a Finished Appliance, nor is it intended for incorporation into Finished Appliances that are made commercially available as single functional units to end users under EU EMC Directive 2004/108/EC and as supported by the European Commission's Guide for the EMC Directive 2004/108/EC (8th February 2010).

This development/evaluation tool complies with EU RoHS2 Directive 2011/65/EU.

For information regarding the exclusive, limited warranties applicable to Microchip products, please see Microchip's standard terms and conditions of sale, which are printed on our sales documentation and available at www.microchip.com.

Signed for and on behalf of Microchip Technology Inc. at Chandler, Arizona, USA

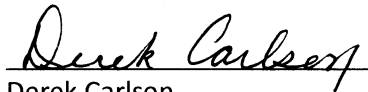

Derek Carlson
VP Development Tools

16-July-2013

Date

NOTES:

Table of Contents

Preface	7
Chapter 1. Overview	
1.1 Introduction	13
1.2 RN-XV-EK1 Evaluation Kit Features	13
1.3 RN-XV-EK1 Evaluation Kit Contents and Part Details	14
1.4 RN-XV-EK1 Evaluation Board Contents	14
1.5 RN-XV-EK1 Evaluation Kit Related Demo Applications	16
Chapter 2. Getting Started	
2.1 Introduction	17
2.2 Hardware Requirements	17
2.3 Software/Utility Requirements	18
2.4 Modules Configuration	18
Chapter 3. Application Interface Concerns	
3.1 Introduction	25
3.2 RN171XV Module Concerns	25
3.3 RN41/42XV Module Concerns	26
Appendix A. RN-XV-EK1 Evaluation Board Schematic and PCB Details	
A.1 Introduction	29
A.2 RN-XV-EK1 Evaluation Board Schematic	29
A.3 RN-XV-EK1 Evaluation Board PCB Layout	31
A.4 RN-XV-EK1 Evaluation Board Bill of Materials	35
A.5 RN-XV-EK1 Physical Dimensions	36
Worldwide Sales and Service	37

NOTES:

Preface

NOTICE TO CUSTOMERS

All documentation becomes dated, and this manual is no exception. Microchip tools and documentation are constantly evolving to meet customer needs, so some actual dialogs and/or tool descriptions may differ from those in this document. Please refer to our web site (www.microchip.com) to obtain the latest documentation available.

Documents are identified with a “DS” number. This number is located on the bottom of each page, in front of the page number. The numbering convention for the DS number is “DSXXXXA”, where “XXXX” is the document number and “A” is the revision level of the document.

For the most up-to-date information on development tools, see the MPLAB® IDE online help. Select the Help menu, and then Topics to open a list of available online help files.

INTRODUCTION

This chapter contains general information that will be useful to know before using the RNXV Evaluation Kit User's Guide. Items discussed in this chapter include:

- [Document Layout](#)
- [Conventions Used in this Guide](#)
- [Warranty Registration](#)
- [Recommended Reading](#)
- [The Microchip Web Site](#)
- [Development Systems Customer Change Notification Service](#)
- [Customer Support](#)
- [Document Revision History](#)

DOCUMENT LAYOUT

This document describes how to use the RNXV Evaluation Kit. The manual layout is as follows:

- **Chapter 1. “Overview”** – This chapter describes the RN-XV-EK1 as an evaluation kit which supports the RNXV series of modules for both Wi-Fi® and Bluetooth® platforms. The board connects to a PC via a standard USB cable which is included in the kit, and provides two push button switches to control WPS mode and to reset the RN171XV module.
- **Chapter 2. “Getting Started”** – This chapter describes the hardware and software setup required to evaluate the RNXV series modules using the RN-XV-EK1 evaluation board. The RNXV modules (sold separately) mount on the evaluation board and contain either the RN171 or RN41/RN42 modules depending on the part number.

RNXV Evaluation Kit User's Guide

- **Chapter 3. “Application Interface Concerns”** – This chapter provides design concerns related to powering the evaluation board, sensor interface settings, mode settings, and restoring factory settings for RN171XV and RN41/42XV modules mounted on RNXV Evaluation Board.
- **Appendix A. “RN-XV-EK1 Evaluation Board Schematic and PCB Details”** – This appendix provides the RN-XV-EK1 Evaluation Boards schematic, PCB layout and Bill of Materials (BOM).

CONVENTIONS USED IN THIS GUIDE

This manual uses the following documentation conventions:

DOCUMENTATION CONVENTIONS

Description	Represents	Examples
Arial font:		
Italic characters	Referenced books	<i>MPLAB® IDE User's Guide</i>
	Emphasized text	...is the <i>only</i> compiler...
Initial caps	A window	the Output window
	A dialog	the Settings dialog
	A menu selection	select Enable Programmer
Quotes	A field name in a window or dialog	"Save project before build"
Underlined, italic text with right angle bracket	A menu path	<i><u>File</u>>Save</i>
Bold characters	A dialog button	Click OK
	A tab	Click the Power tab
Text in angle brackets < >	A key on the keyboard	Press <Enter>, <F1>
Courier New font:		
Plain Courier New	Sample source code	#define START
	Filenames	autoexec.bat
	File paths	c:\mcc18\h
	Keywords	_asm, _endasm, static
	Command-line options	-Opa+, -Opa-
	Bit values	0, 1
	Constants	0xFF, 'A'
Italic Courier New	A variable argument	<i>file.o</i> , where <i>file</i> can be any valid filename
Square brackets []	Optional arguments	mcc18 [options] <i>file</i> [options]
Curly brackets and pipe character: { }	Choice of mutually exclusive arguments; an OR selection	errorlevel {0 1}
Ellipses...	Replaces repeated text	var_name [, var_name...]
	Represents code supplied by user	void main (void) { ... }

WARRANTY REGISTRATION

Please complete the enclosed Warranty Registration Card and mail it promptly. Sending in the Warranty Registration Card entitles you to receive new product updates. Interim software releases are available at the Microchip web site.

RECOMMENDED READING

This user's guide describes how to use the RNXV Evaluation Board. Other useful documents are listed below. The following Microchip documents are available and recommended as supplemental reference resources.

RN171 Module Data Sheet (DS75084)

RN171XV Module Data Sheet

RN41 Module Data Sheet

RN42 Module Data Sheet

RN41XV-RN42XV Module Data Sheet

PICDEM™ PIC18 Explorer Demonstration Board User's Guide (DS51721)

Explorer 16 Development Board User's Guide (DS51589)

WiFly Command Reference, Advanced Features and Applications User's Guide

RNXV Evaluation Kit User's Guide

THE MICROCHIP WEB SITE

Microchip provides online support through our web site at <http://www.microchip.com>. This web site is used as a means to make files and information easily available to customers. Accessible by using your favorite Internet browser, the web site contains the following information:

- **Product Support** – Data sheets and errata, application notes and sample programs, design resources, user's guides and hardware support documents, latest software releases and archived software
- **General Technical Support** – Frequently Asked Questions (FAQs), technical support requests, online discussion groups, Microchip consultant program member listing
- **Business of Microchip** – Product selector and ordering guides, latest Microchip press releases, listing of seminars and events, listings of Microchip sales offices, distributors and factory representatives

DEVELOPMENT SYSTEMS CUSTOMER CHANGE NOTIFICATION SERVICE

Microchip's customer notification service helps keep customers current on Microchip products. Subscribers will receive e-mail notification whenever there are changes, updates, revisions or errata related to a specified product family or development tool of interest.

To register, access the Microchip web site at <http://www.microchip.com>, click **Customer Change Notification** and follow the registration instructions.

The Development Systems product group categories are:

- **Compilers** – The latest information on Microchip C compilers and other language tools. These include the MPLAB[®] C compiler; MPASM[™] and MPLAB 16-bit assemblers; MPLINK[™] and MPLAB 16-bit object linkers; and MPLIB[™] and MPLAB 16-bit object librarians.
- **Emulators** – The latest information on the Microchip MPLAB REAL ICE[™] in-circuit emulator.
- **In-Circuit Debuggers** – The latest information on the Microchip in-circuit debugger, MPLAB ICD 3.
- **MPLAB[®] IDE** – The latest information on Microchip MPLAB IDE, the Windows[®] Integrated Development Environment for development systems tools. This list is focused on the MPLAB IDE, MPLAB SIM simulator, MPLAB IDE Project Manager and general editing and debugging features.
- **Programmiers** – The latest information on Microchip programmers. These include the MPLAB PM3 device programmers and the PICkit[™] 3 development programmers.

CUSTOMER SUPPORT

Users of Microchip products can receive assistance through several channels:

- Distributor or Representative
- Local Sales Office
- Field Application Engineer (FAE)
- Technical Support

Customers should contact their distributor, representative or FAE for support. Local sales offices are also available to help customers. A listing of sales offices and locations is included in the back of this document.

Technical support is available through our web site at: <http://support.microchip.com>

DOCUMENT REVISION HISTORY

Revision A (December 2013)

This is the initial released version of the document.

RNXV Evaluation Kit User's Guide

NOTES:

Chapter 1. Overview

1.1 INTRODUCTION

The RN-XV-EK1 is an evaluation kit to support the RNXV series of modules for both Wi-Fi® and Bluetooth® platforms. The board connects to a PC via a standard USB cable which is included in the kit, and provides 2 push button switches to control WPS mode and to reset the RN171XV module. The board has connectors to connect to the RNXV module, as well as headers that enables prototyping. It is compatible with all RNXV antenna options. The kit does not include any RNXV modules.

The RNXV modules have certified Bluetooth or Wi-Fi connectivity which are helpful in replacing the existing systems with 802.15.4 modules. The RNXV modules are pre-loaded with firmware to simplify integration and minimize applications development time. The modules are based on the popular 2 x 10 (2mm) socket footprint often found in embedded applications.

The RNXV Evaluation Kit details can be downloaded from the Microchip web site <http://www.microchip.com/RN-XV-EK1>.

This chapter discusses the following topics:

- [RN-XV-EK1 Evaluation Kit Features](#)
- [RN-XV-EK1 Evaluation Kit Contents and Part Details](#)
- [RN-XV-EK1 Evaluation Board Contents](#)
- [RN-XV-EK1 Evaluation Kit Related Demo Applications](#)

1.2 RN-XV-EK1 EVALUATION KIT FEATURES

The RNXV Evaluation Kit has the following features:

- Supports ultra low-power FCC/CE/IC certified 2.4 GHz IEEE 802.11b/g RN171 module through RN171XV
- Supports low-power FCC/CE/IC certified 2.4 GHz IEEE 802.15.1 RN41/42 modules through RN41/42XV
- Supports several antenna options, depending on the RN171XV, RN41XV and RN42XV modules selected
- Powers up RN171XV, RN41XV and RN42XV modules
- Supports WPS (FN) push button for easy configuration of RN171XV module
- Reset (RST) push button wakes the RN171XV module
- Standard USB mini connector
- Hardware interface: USB via FTDI chip
- Brings the RNXV signals out on headers for easy debugging
- The evaluation board's moisture sensitivity level (MSL) is 1
- Size - 1.58" x 1" x 0.25"
- Weight - Approx. 6.5 g

RNXV Evaluation Kit User's Guide

1.3 RN-XV-EK1 EVALUATION KIT CONTENTS AND PART DETAILS

The package kit contents contain the following development tools listed in [Table 1-1](#) with part number details.

TABLE 1-1: RNXV EVALUATION KIT CONTENTS

Description	Part Number
RNXV Evaluation Board	RN-XV-EK1
USB cable	

[Figure 1-1](#) illustrates the evaluation kit contents of RN-XV-EK1.

FIGURE 1-1: RNXV EVALUATION KIT CONTENTS

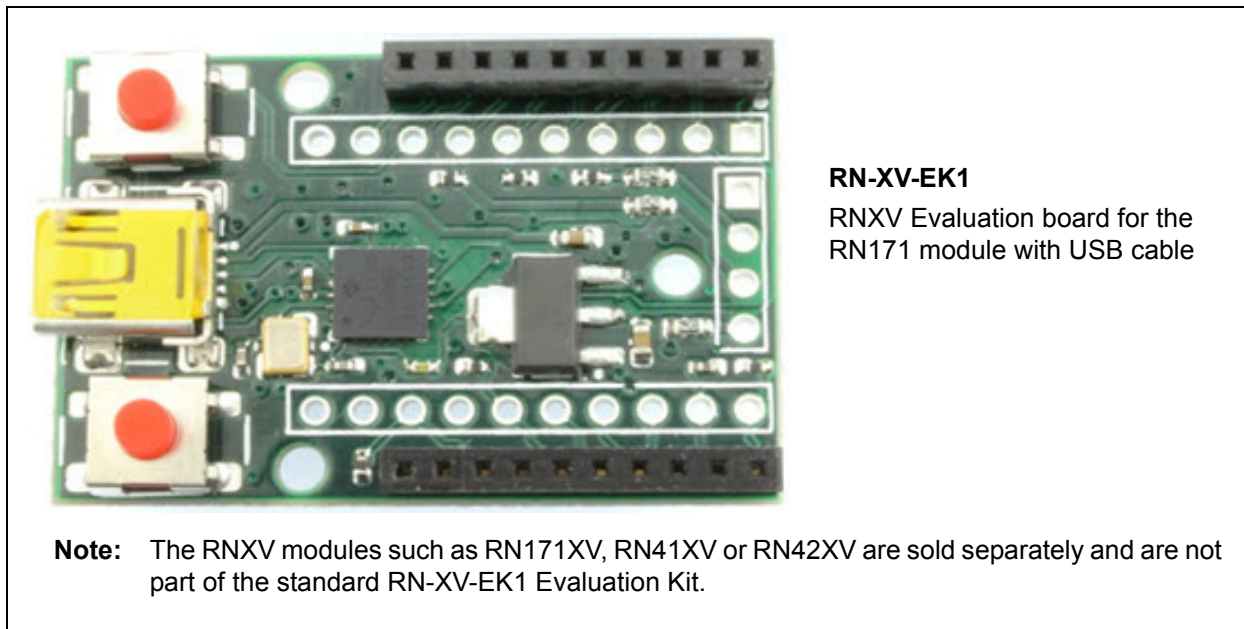

1.4 RN-XV-EK1 EVALUATION BOARD CONTENTS

This section describes the hardware for RN-XV-EK1 Evaluation board, which enables user to evaluate the RNXV modules. The RNXV modules, which are sold separately, is mounted on the evaluation board and contains the RNXV Wi-Fi or Bluetooth.

[Figure 1-2](#) shows the RN-XV-EK1 components.

FIGURE 1-2: RN-XV-EK1 EVALUATION BOARD COMPONENTS

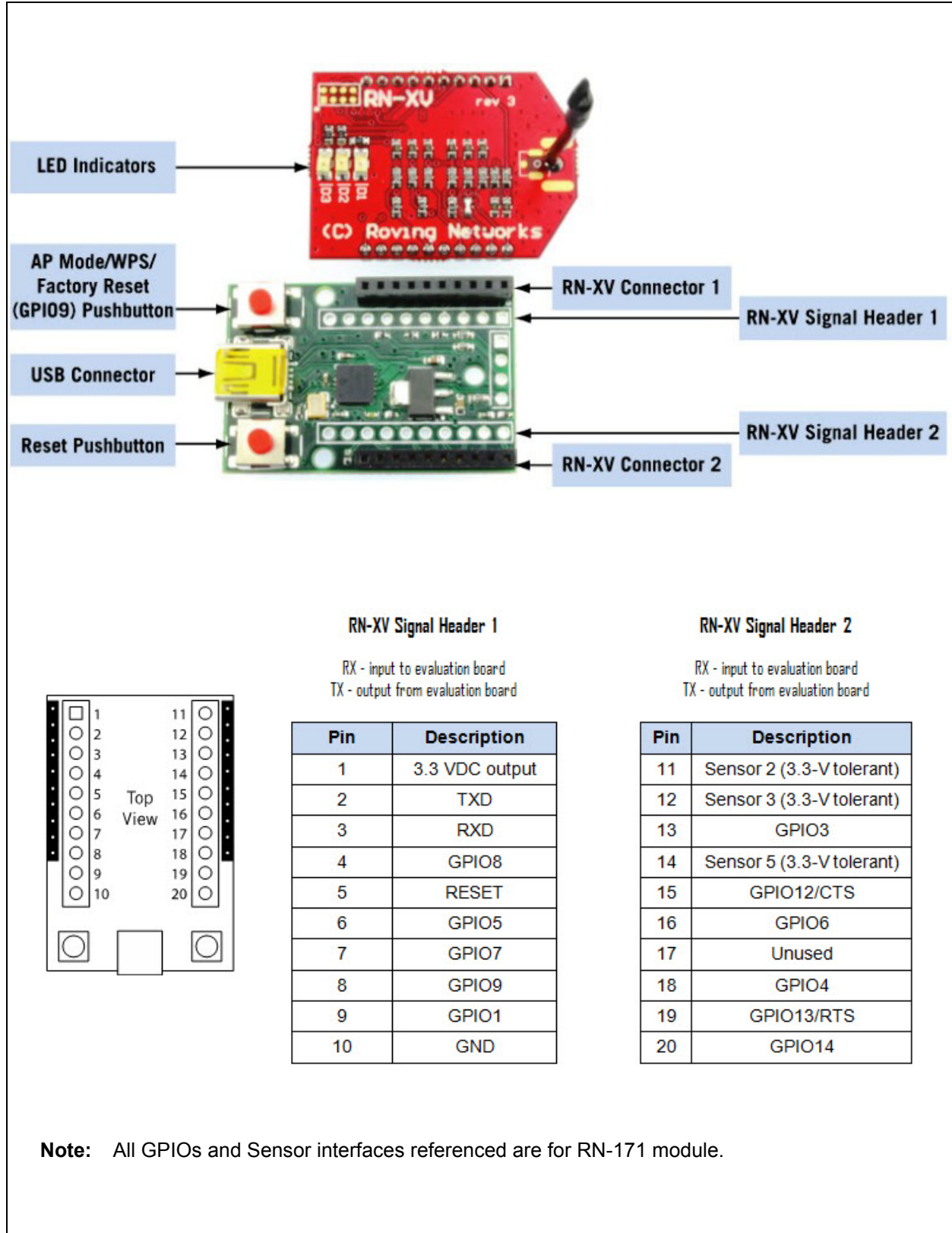

RNXV Evaluation Kit User's Guide

Table 1-2 gives details on the hardware availability with module interface.

TABLE 1-2: RNXV EVALUATION KIT HARDWARE AVAILABILITY WITH MODULE INTERFACE

Hardware	Description	RN-XV-EK1 with RN171XV	RN-XV-EK1 with RN41/42XV
Evaluation Board	Contains connectors for Wi-Fi/Bluetooth modules.	For RN171 Module	For RN41/42 module
Power-Up	Interface for powering up the evaluation boards.	USB	USB
Push Buttons	To enter RESET and WPS (Wi-Fi Protected Setup) mode in RN171XV module.	Available	Available
Communication Interface	UART and USB	Available	Available
USB Connector On-board	Provides power to the evaluation board and supports communication (COM Port).	Available	Available
Antenna Connections	Supported by RNXV modules based on the module selected.	No	No

1.5 RN-XV-EK1 EVALUATION KIT RELATED DEMO APPLICATIONS

Resources related to RN-XV-EK1 can be downloaded from the Microchip web site <http://www.microchip.com/RN-XV-EK1>.

Note: For details on working with RN171 module firmware, refer to “*WiFi Command Reference, Advanced Features and Applications User's Guide*”; and for RN41/41 module, refer to the *Bluetooth Command Reference & Advanced Information User's Guide* from the Microchip web site <http://www.microchip.com>.

Chapter 2. Getting Started

2.1 INTRODUCTION

This chapter describes the hardware and software setup required to evaluate the RNXV series modules using the RN-XV-EK1 evaluation board. The RNXV modules (sold separately) mount on the evaluation board and contain either the RN171 or RN41/RN42 modules depending on the part number. The board connects to a PC or embedded controllers via the standard USB cable serial port interface. The evaluation board also provides two push button switches to control (Wi-Fi Protected Setup) WPS mode and to reset the module without any software configuration while using RN171XV module. The board has connectors to drop in the RNXV, as well as headers that enable wires access to the RNXV signals.

This chapter discusses the following topics:

- [Hardware Requirements](#)
- [Software/Utility Requirements](#)
- [Modules Configuration](#)

2.2 HARDWARE REQUIREMENTS

The RN-XV-EK1 requires RN171XV or RN41XV/RN42XV boards along with an USB cable as its hardware setup for connection with PC/laptop and to run the demo applications.

The following are the steps to setup the Evaluation Board demo:

1. Mount RN171XV or RN41/42XV to RN-XV-EK1 evaluation board on the available connector headers.
2. Power-up the modules/board through the USB cable via computer/laptop.
3. Download and install the FTDI drivers from the Microchip web site.
4. Once the FTDI drivers are installed, the COM port is automatically assigned based on the active connection.

[Figure 2-1](#) shows the completed RN-VX-EK1 evaluation board hardware setup with RN171XV board (RN171 as module base).

FIGURE 2-1: HARDWARE SETUP WITH RN171XV BOARD



2.3 SOFTWARE/UTILITY REQUIREMENTS

The following software tools/utilities are required to run the demo applications:

- Terminal Emulator Application such as TeraTerm (for Windows OS) or CoolTerm (for MAC OS). The Terminal Emulator program is used to send the configuration commands to the module over a UART interface. The emulator also displays information transmitted from the module.
- RN-XV-EK1 board uses the FTDI chip set. Windows automatically installs the drivers for the USB-serial cable. If the drivers are not automatically installed, download and install the FTDI drivers from the Microchip web site "<http://ww1.microchip.com/downloads/en/DeviceDoc/FTDI-Drivers.zip>" FTDI Chipset Drivers.
- Once the FTDI drivers are installed, the COM port is automatically assigned based on the active connection.

2.4 MODULES CONFIGURATION

RN171XV CONFIGURATION

RN171XV with RN171 as module base is mounted on RNXV Evaluation Kit. The RN171 operates in two modes:

- Data mode (default)
- Command mode

2.4.1 Data Mode

In Data mode, the RN171 module is essentially a data pipe. When the module receives data over Wi-Fi, it strips the TCP/IP or UDP headers and trailers, and passes the user payload data to the UART. When data is written to the UART, the module constructs the TCP/IP packet and sends it out over Wi-Fi. Thus, the entire process of sending/receiving data to the host is transparent to the end application/user microcontroller.

FIGURE 2-2: APPLICATION INTERFACE FOR DATA AND COMMAND MODES

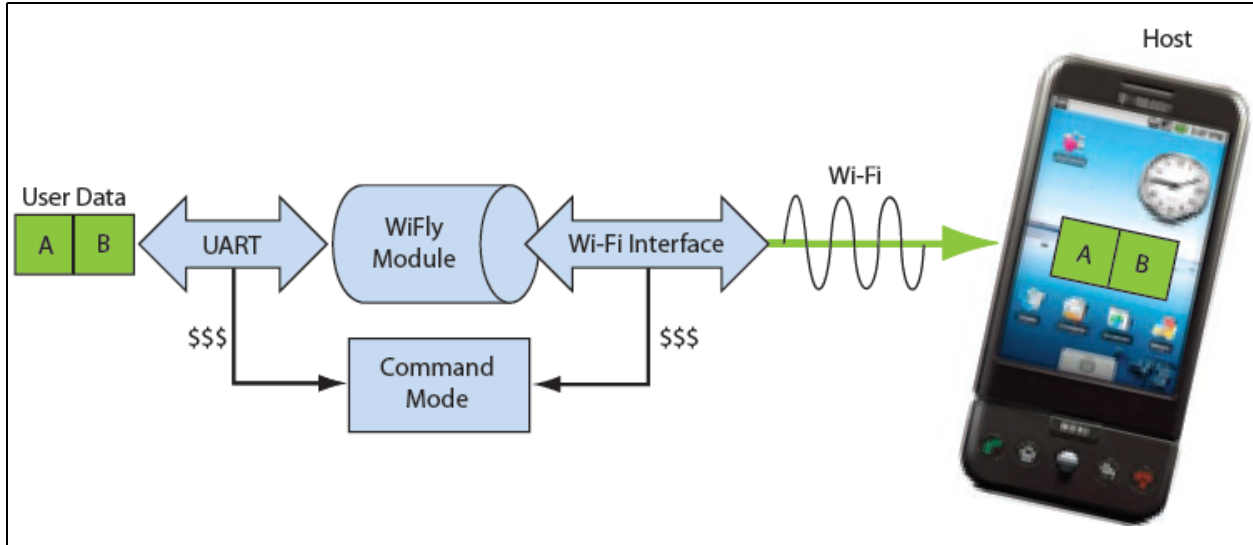

2.4.2 Command Mode

By default, the RN171 module is in Data mode. Sending an escape sequence \$\$\$ causes the module to enter the Command mode. Once in Command mode, the module can be configured using simple ASCII commands. To exit Command mode and return to the Data mode, type `exit <cr>`. Figure 2-2 shows an application interface for Data and Command modes.

Basic configuration requires the wireless network access point's name (SSID) and the authentication password. The RN171 module can associate with only one network at a time. It is recommended to begin evaluation by configuring the RN171 module using an open access point to simplify the setup.

The following two methods are used to configure the RN171 module:

1. Over the UART, that is connected to a computer/laptop or to a microcontroller
2. Through Wi-Fi using Ad hoc networking

Terminal emulator utility is required to type the commands and to monitor the activity/transactions.

2.4.3 Configuration Using a USB Cable

The evaluation board uses a USB cable to enable the host computer to communicate with the RN171 module on the evaluation board. The procedures in this section describe how to use a terminal emulator to go into Configuration mode, send commands to find networks, associate with an access point, and save configuration.

2.4.3.1 CONFIGURE THE MODULE USING A TERMINAL EMULATOR

Either the TeraTerm (for Windows OS) or CoolTerm (for Mac OS-X), terminal emulator utility can be used. Also legacy evaluation boards use a USB-to-serial cable for connecting the evaluation board with the computer/laptop. When using the RN171 evaluation board, use the COM port to which the USB-to-serial cable is connected.

The following are the steps to communicate with the module using a terminal emulator:

1. Determine the COM port that is assigned to the USB cable (the port is COM9 in the example shown in [Figure 2-3](#)).
2. Open the available terminal emulation program and specify the COM port.
3. When using TeraTerm, go to Serial option and select the COM port number from the drop-down menu.
4. The serial port with the required settings are as follows:
 - Baud: 9600
 - Data bits: 8
 - Parity: None
 - Stop bits: 1
 - Flow control: None
5. Type the commands through the terminal emulator program and to the assigned program.

Note: The COM port number is found in the following location path:

- For Windows OS: Open Computer Management. Click on System Tools>Device Manager. Browse to Ports (COM & LPT) and expand the selection for serial ports. Use TeraTerm for other configuration settings and monitoring. This is illustrated in [Figure 2-3](#).
- For MAC OS: When using CoolTerm, view and select the port from the same terminal emulator application.

FIGURE 2-3: FINDING THE COM PORT NUMBER IN WINDOWS

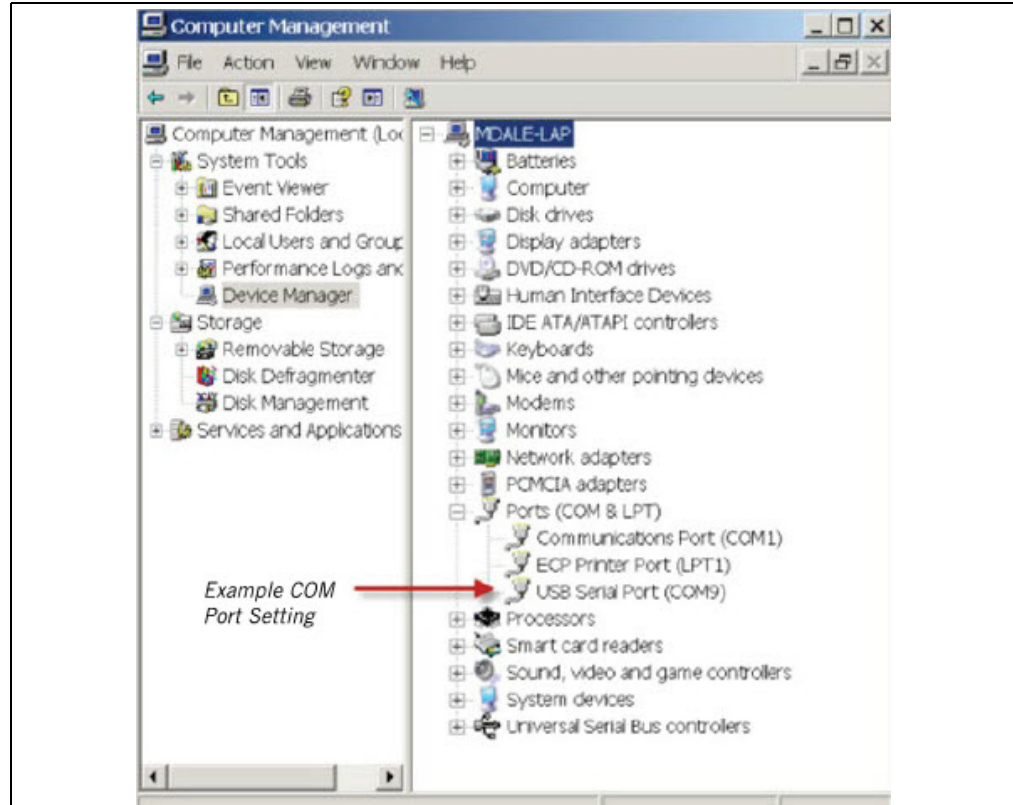

2.4.3.2 ENTER COMMAND MODE

The following are the steps to enter the Command mode in a terminal emulator:

1. Type \$\$\$ on the keyboard sequentially with no additional characters before or after each \$ sign. The module replies with CMD (on terminal emulator) to indicate that it is in Command mode.
2. Type show net <cr> to display the current network settings (Figure 2-4 shows the current network settings for version 2.28).

Note: When a command is completed, the terminal displays a prompt using the format <X.XX>, where X.XX indicates the module's firmware version.

FIGURE 2-4: CURRENT NETWORK SETTINGS

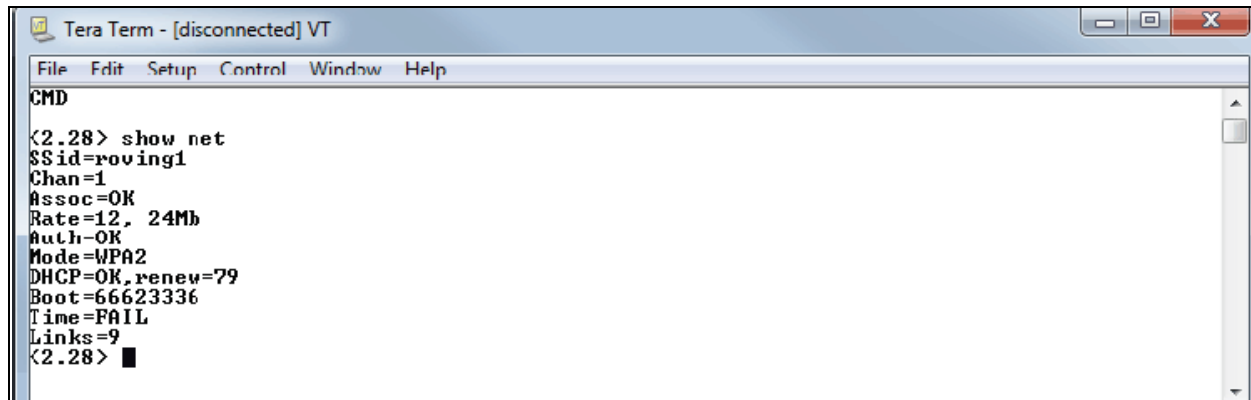

RNXV Evaluation Kit User's Guide

The RN171 module supports a variety of command keywords. The WiFly Command Reference, Advanced Features and Applications User's Guide from the Microchip web site <http://www.microchip.com> provides a complete list of command reference.

RN41/42XV CONFIGURATION

RN41/42XV with RN41/42 module base is mounted on RNXV Evaluation Kit. The RN41/42 also operates in two modes:

- Data mode (default)
- Command mode

While in Data mode, the module operates as a data pipe. When the module receives data, it strips the Bluetooth headers and trailers and passes the user data to the UART port. When data is written to the UART port, the module constructs the Bluetooth packet and sends it out over the Bluetooth wireless connection. Thus, the entire process of sending/receiving data to the host is transparent to the end microcontroller. The [Figure 2-5](#) illustrates the operational modes.

FIGURE 2-5: DATA & COMMAND MODES

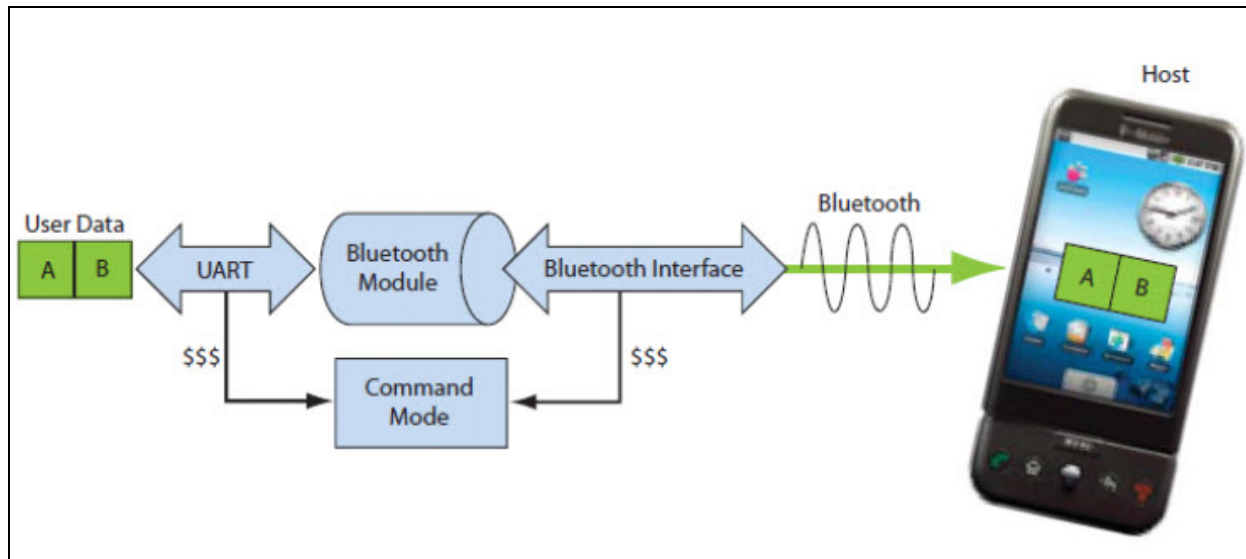

The default configuration for the Bluetooth module is:

- Bluetooth slave mode
- Bluetooth pin code 1234
- Serial port 115,200 Kbps baud rate, 8 bits, no parity, 1 stop bit
- Serial port flow control disabled
- Low-power mode off

Configuration is done by putting the module in the Command mode and sending ASCII commands over the UART port or the Bluetooth link. Reboot the module for settings to take effect. The changed configuration parameters persist until next change happens or until a factory reset is performed.

There are two ways to configure the Bluetooth module:

- Local configuration using computer's serial port
- Via Bluetooth

Terminal emulator utility is required to type the commands and to monitor the activity/ transactions.

2.4.4 Configuring the Module over the UART Port

Connect the module to any computer/laptop. Connection can be done using the RS-232 DB9 port or via a USB cable. When RN-XV-EK1 evaluation board is used as RN41/42XV base board, connection is done using a USB cable.

With the Bluetooth module connected and powered on, run a terminal emulator and open the COM port to which the cable is connected. The terminal emulator's communication settings must be the default serial port settings:

- Baud rate 115,200 kbps
- 8 bits
- No parity
- 1 stop bit
- Hardware flow control enabled

Note: Use local configuration at any time when the module does NOT have a Bluetooth connection, as well as under certain conditions. If the module is in Configuration mode and a connection occurs, the module exits the Configuration mode and data passes back and forth from the remote module.

Once a connection is made, Command mode can be entered only if the boot-up configuration timer has not expired (60 seconds). To remain in Configuration mode, set the configuration timer to 225.

2.4.5 Remote Configuration Using Bluetooth

It is often useful to configure the module remotely over a Bluetooth connection. Before performing remote configuration using Bluetooth, first pair the Bluetooth module with any computer. For computer/laptop with Bluetooth capability and running Windows, click **Bluetooth devices** in the system tray at the bottom right of the computer screen. Select **Add a Bluetooth device** and follow the on-screen instructions. For Mac OS-X, click the Bluetooth icon, select **Setup Bluetooth device** and follow the on-screen instructions. Once a connection is made, the module enters the command mode if the boot-up configuration timer has not expired (60 seconds). To remain in Configuration mode, set the configuration timer to 255.

When the configuration is finished, reset the module or send the --- command, which causes the module to exit Configuration mode and enables data to pass normally.

Note: Configuration mode (local or remote) is NEVER enabled when the module is in auto-mode and is connected over Bluetooth.

2.4.6 Enter Command Mode

To enter Command mode, launch a terminal emulator and specify the module's default settings. [Table 2-1](#) shows the serial port settings.

TABLE 2-1: SERIAL PORT SETTINGS

Setting	Value
Port	COM port to which module is attached
Baud rate	115200
Data rate	8 bits
Parity	None
Stop bits	1
Flow control	None

RNXV Evaluation Kit User's Guide

Type \$\$\$ into the terminal emulator to enter Command mode.

The module returns the string `CMD`, which indicates that the connection and terminal settings are correct. While in Command mode, the module accepts ASCII bytes as commands. When a valid command is entered, the module returns `AOK`. It returns `ERR` for an invalid command and `?` for unrecognized commands. Type `h <cr>` to see a list of commands.

A quick check to confirm that user has entered the Command mode is to type the `x <cr>` command after entering Command mode. This command shows summary of the module's current settings, such as the Bluetooth name, device class and serial port settings. Figure 2-6 illustrates the view of current settings.

FIGURE 2-6: VIEW CURRENT SETTINGS

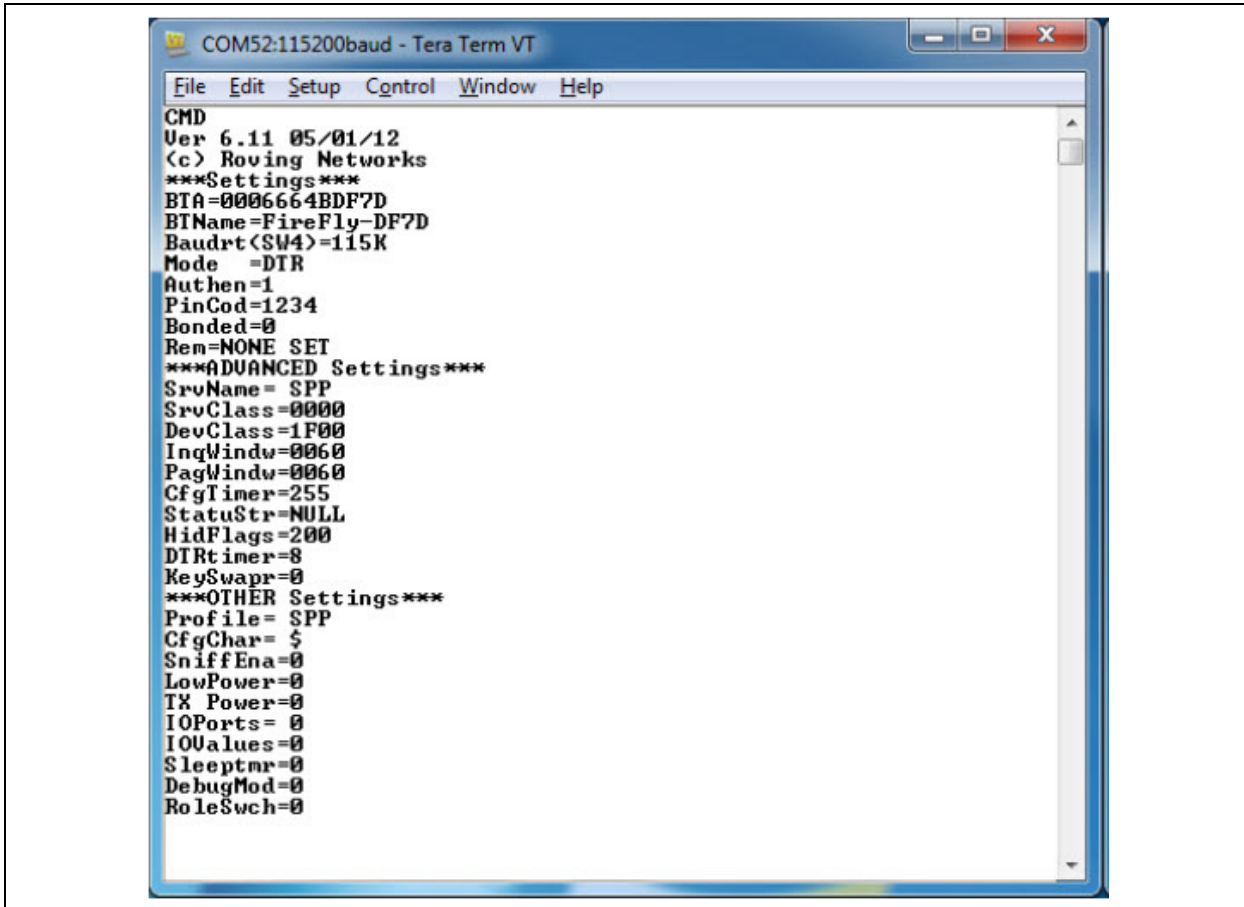
A screenshot of a terminal window titled "COM52:115200baud - Tera Term VT". The window has a menu bar with "File", "Edit", "Setup", "Control", "Window", and "Help". The terminal content shows the following text:

```
CMD
Ver 6.11 05/01/12
(c) Roving Networks
***Settings***
BTA=0006664BDF7D
BTName=FireFly-DF7D
Baudrt(SW4)=115K
Mode =DTR
Authen=1
PinCod=1234
Bonded=0
Rem=NONE SET
***ADVANCED Settings***
SrvName= SPP
SrvClass=0000
DevClass=1F00
InqWindw=0060
PagWindw=0060
CfgTimer=255
StatuStr=NULL
HidFlags=200
DIRtimer=8
KeySwapr=0
***OTHER Settings***
Profile= SPP
CfgChar= $
SniffEna=0
LowPower=0
TX Power=0
IOPorts= 0
IOValues=0
Sleptmr=0
DebugMod=0
RoleSwch=0
```

To return to data mode, type `--- <cr>` or reset the module and re-connect.

The RN41/42 modules support a variety of command keywords. The Bluetooth Data Module Command Reference & Advanced Information User's Guide from the Microchip web site <http://www.microchip.com/bluetooth> provides a complete list of command reference.

Chapter 3. Application Interface Concerns

3.1 INTRODUCTION

This section provides the design concerns related to powering the evaluation board, sensor interface settings, mode settings and restoring factory settings for RN171XV and RN41/42XV modules mounted on RNXV Evaluation Board.

3.2 RN171XV MODULE CONCERNS

3.2.1 Powering the Module

The RN171XV module is powered using 5V supplied from USB host connected to RN-XV-EK1 board.

3.2.2 Sensor Interfaces

The module input voltage on the sensor inputs must not exceed 1.2V. The Analog-to-Digital Converter (ADC) saturates at 400 mV. It is recommended to use the sensor power output to drive analog devices that are attached to the sensor pins.

Note: The RN-XV adds an extra voltage divider on the SENSOR inputs. Sensor pins 2 and 3 have a resistor network (using 400 kohms and 100 kohms) in front of sensors 4 and 5, respectively. Hence, the SENSOR inputs on the RN-XV saturate the ADC at 2280mV and can accept up to 5V.

3.2.3 Sensor Inputs

For RN-171-XV connector pins 13, 15, 18, and 19 can be configured as GPIO pins or sensor inputs, depending on the installed resistors.

- *Sensor inputs* - Pins 19 and 20
- *GPIOs* - Pins 13, 15, and 18

For details, refer to “RN-171-XV 802.11 b/g Wireless LAN Module Datasheet” from the Microchip web site <http://www.microchip.com>.

3.2.4 GPIO9 Functions

The AP push button is connected to GPIO9. Depending on the state of GPIO9, the module enters into three different modes: AP mode, Factory reset and WPS mode.

3.2.4.1 AP MODE

To put the module into AP mode, GPIO9 must be high when the module powers up or wakes from a sleep state. Press the AP mode button to drive GPIO9 high, and then press the RESET button to reset the module. The module is in default AP mode, which creates a default access point network with the default parameters as listed in [Table 3-1](#).

Note: This default mode overwrites any software settings.

TABLE 3-1: DEFAULT AP MODE SETTINGS

Setting	AP Mode Default
SSID	WiFiFlyAP-XX, where XX is the last two bytes of the module's MAC address
Channel	1
DHCP Server	Enabled
IP Address	1.2.3.4
Netmask	255.255.255.0
Gateway	1.2.3.4

Once the module boots, other Wi-Fi-enabled devices (such as, computers, iPhones, iPads, Android tablets, etc.) are able to find the module when access points are scanned.

3.2.4.2 FACTORY RESET

In Factory Reset mode, the module is restored to the factory defaults.

Perform the following steps to restore the defaults:

1. Put the module into default AP mode as described in **AP Mode**.
2. Press the **AP Mode** push button 5 times (with 1 or more seconds interval between presses).

This feature is useful in case the module is misconfigured and is no longer responding.

3.2.5 Reset

The RESET push button reboots the module.

3.3 RN41/42XV MODULE CONCERNS

The following sections provide information on designing with the RN41XV and RN42XV module, including radio interference, factory reset, connection status, etc.

3.3.1 Powering the Module

Apply ONLY 3.3 V \pm 10% regulated power to pin 1 (VDD) and pin 10 (GND). The module does not have an on-board voltage regulator and MUST be powered from a regulated 3.3 V power supply (3.3 V VDC output).

3.3.2 Reset Circuit

The RN41XV and RN42XV modules contain a 1k Ω pull-up to VDD, and the reset polarity is active low. The module's reset pin has an optional power-on reset circuit with a delay, which must only be required if the input power supply has a very slow ramp or tends to bounce or have instability on power-up. Often a microcontroller or embedded CPU I/O is available to generate the reset once power is stable. If not, designers can use one of the many low-cost power supervisor chips currently available, such as the MCP809, and MCP102/121.

3.3.3 GPIO and Sensor Configuration

For RN41XV and RN42XV Bluetooth Module connectors, the available pins can be configured as GPIO pins or sensor inputs, depending on the installed resistors.

- *Sensor inputs* - Pins 4, 6, 7, 8, 13, 15, 17 and 18
- *GPIOs* - Pins 9 and 11

For details, refer to "*RN41XV & RN42XV Bluetooth Module Datasheet*" from the Microchip web site <http://www.microchip.com>.

3.3.4 Factory Reset Using GPIO4

It is recommended that designers connect GPIO4 (pin 8) to a switch, jumper, or resistor so it can be accessed. This pin is used to reset the module to its factory default settings, which is critical in situations where the module has not been properly configured. To reset the module to the factory defaults, GPIO4 should be high on power-up and then toggle low-to-high twice (simultaneously) with one second interval between the transitions.

3.3.5 Connection Status

The RN41XV and RN42XV modules have an on-board green LED to indicate the connection status. The connection status LED is located in the lower right corner of the module.

TABLE 3-2: CONNECTION STATUS LED

Setting	AP Mode Default
Blink at 1 Hz	The module is discoverable and waiting for a connection.
Blink at 10 Hz	The module is in command mode.
Solid	The module is connected to another device over Bluetooth.

RNXV Evaluation Kit User's Guide

NOTES:

Appendix A. RN-XV-EK1 Evaluation Board Schematic and PCB Details

A.1 INTRODUCTION

This appendix provides the RN-XV-EK1 Evaluation Board schematic, PCB layout and Bill of Materials (BOM).

- [RN-XV-EK1 Evaluation Board Schematic](#)
- [RN-XV-EK1 Evaluation Board PCB Layout](#)
- [RN-XV-EK1 Evaluation Board Bill of Materials](#)
- [RN-XV-EK1 Physical Dimensions](#)

A.2 RN-XV-EK1 EVALUATION BOARD SCHEMATIC

[Figure A-1](#) shows the Evaluation Board schematic.

FIGURE A-1: RN-XV-EK1 EVALUATION BOARD SCHEMATIC

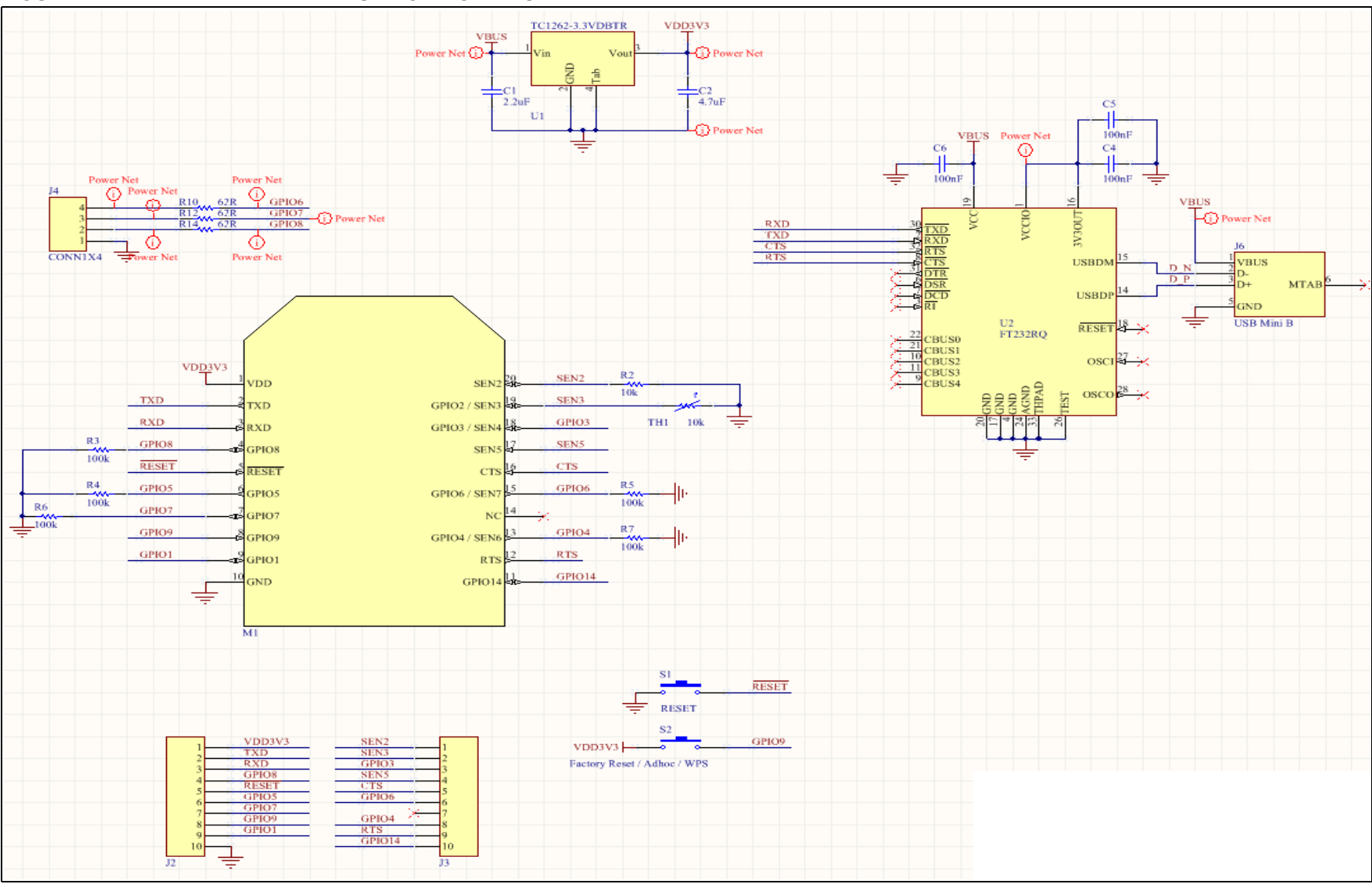

A.3 RN-XV-EK1 EVALUATION BOARD PCB LAYOUT

The RN-XV-EK1 Evaluation Board is a 2-layer, FR4, 0.062 inch, plated through hole PCB construction. [Figure A-2](#) through [Figure A-6](#) show the PCB constructions and Assembly Drawings.

FIGURE A-2: RN-XV-EK1 EVALUATION BOARD TOP SILKSCREEN

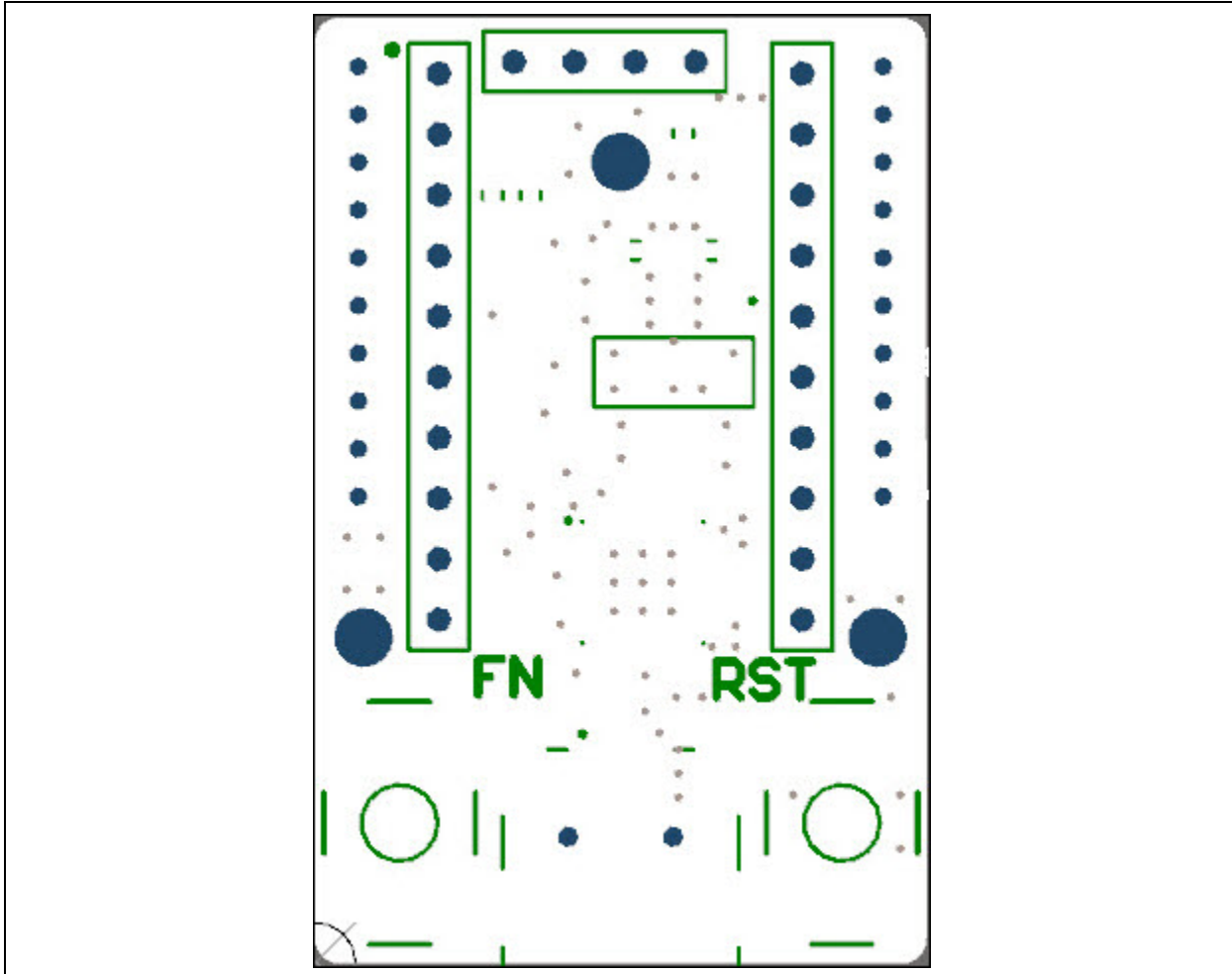

FIGURE A-3: RN-XV-EK1 EVALUATION BOARD BOTTOM SILKSCREEN

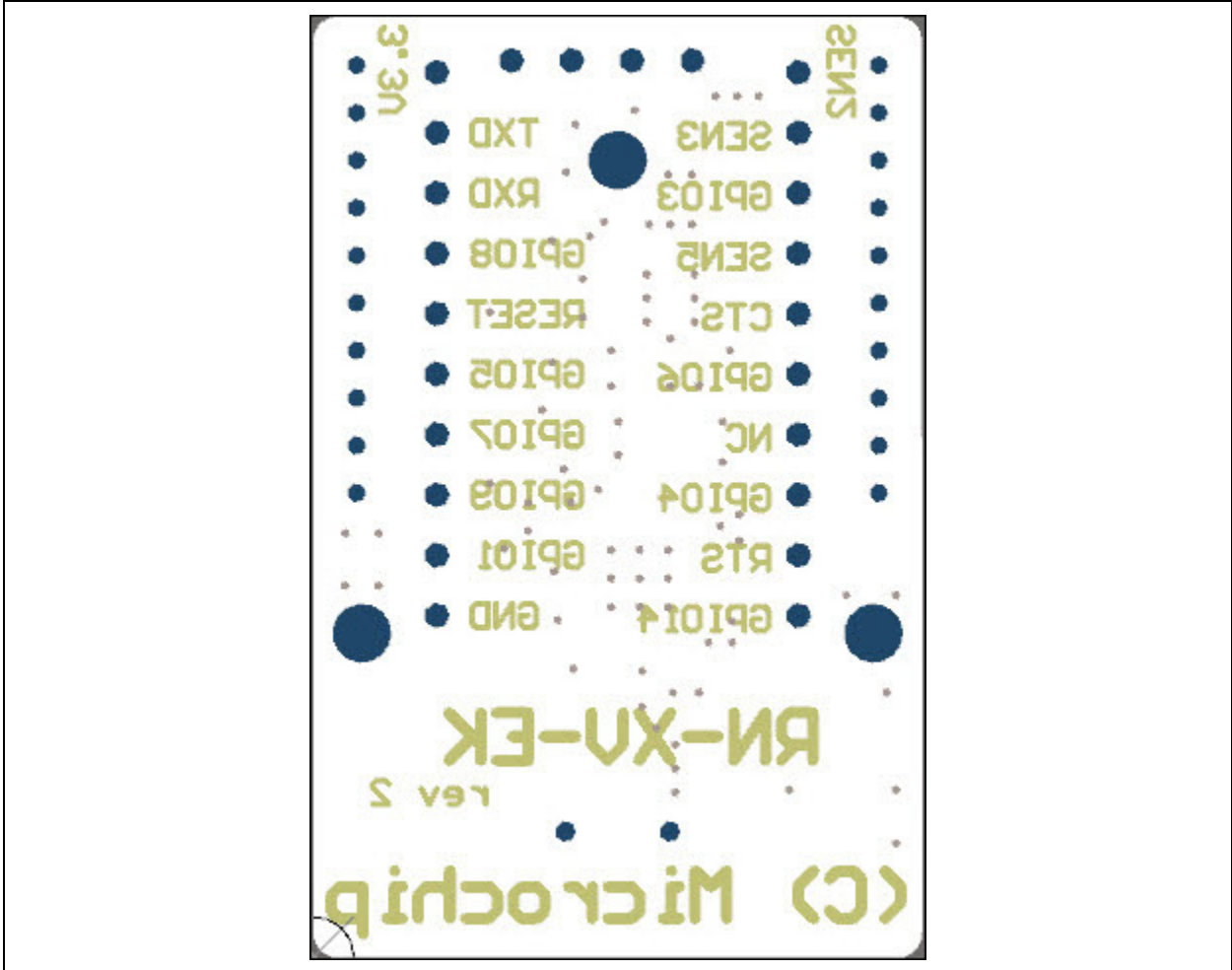

FIGURE A-4: RN-XV-EK1 EVALUATION BOARD TOP COPPER

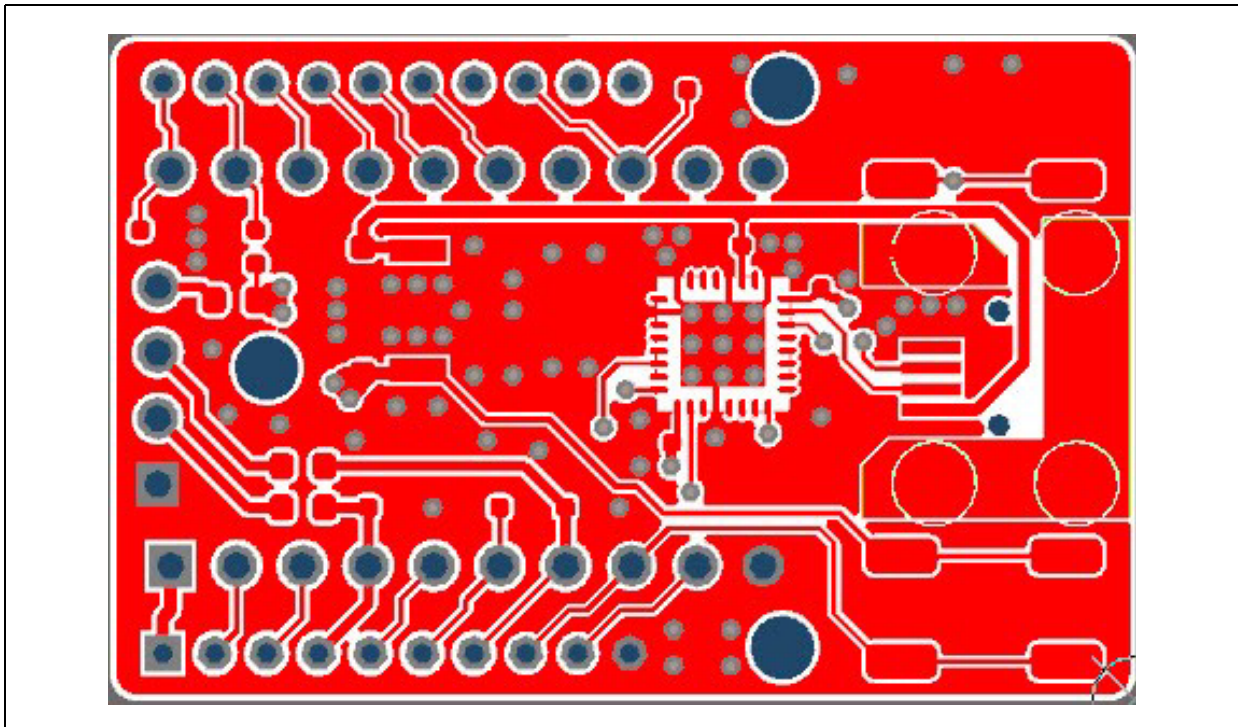
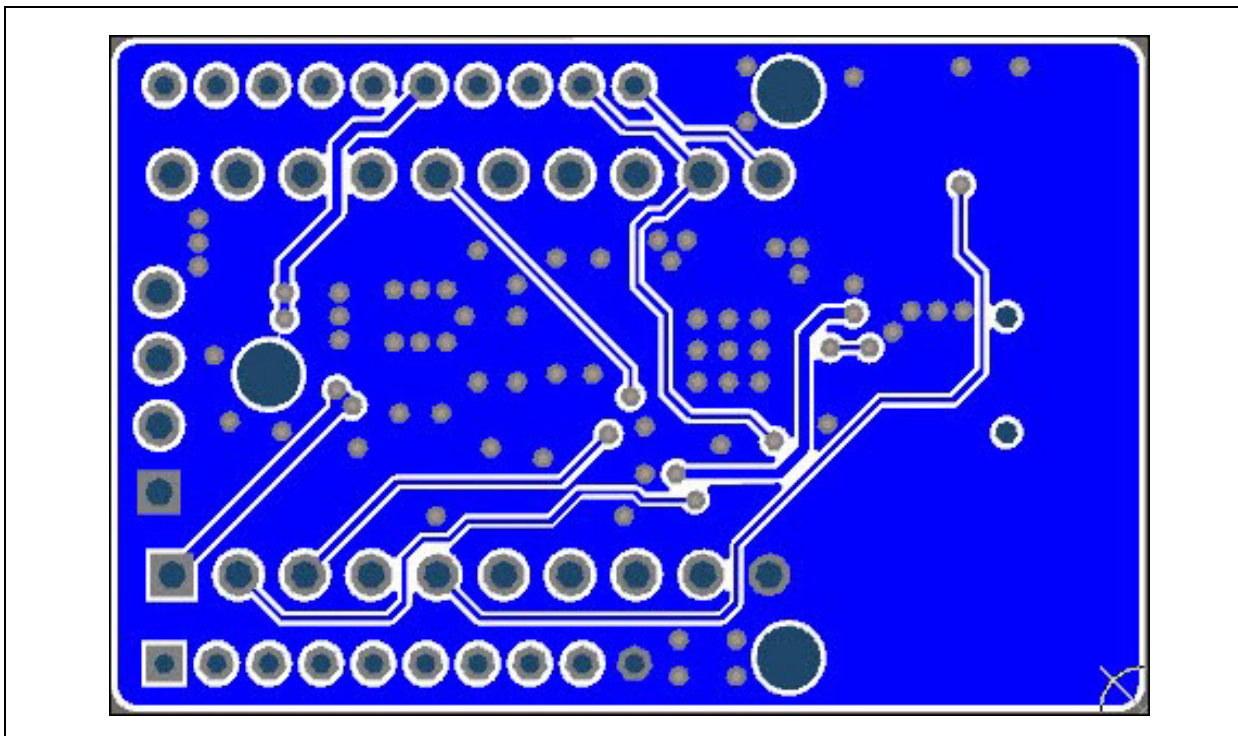

FIGURE A-5: RN-XV-EK1 EVALUATION BOARD BOTTOM COPPER



A.4 RN-XV-EK1 EVALUATION BOARD BILL OF MATERIALS

TABLE A-1: RN-XV-EK1 EVALUATION BOARD BILL OF MATERIALS (BOM)

Reference	Value	Description	Vendor	Vendor P/N
C1	2.2uF	Cap ceramic, -20%, 80%, 16V, Y5V, 0603	TDK Corporation	C1608Y5V1C225Z
C2	4.7uF	Cap ceramic, 10%, 6.3V, X5R, 0603	Kemet	C0603C475K9PACTU
C4, C5, C6	100 nF	Cap ceramic, -20%, 80%, 16V, Y5V, 0402	Yageo	CC0402ZRY5V7BB104
J6	USB Mini B	CONN USB RCPT MINI B 5PS R/A SMD	JAE	DX2R005HN2E700
M1	—	RN-X Module - 2 x 10 pin female 2mm header	Microchip	RN-XV
R2	10k	Res, 0.5%, 1/16W, 0402	Susumu	RR0510P-103-D
R3, R4, R5, R6, R7	100k	Res, 5%, 0.1W, 0402	Panasonic - ECG	ERJ-2GEJ104X
R10, R12, R14	62R	thick film, 5%, 0.1W, 0603	Panasonic - ECG	ERJ-3GEYJ620V
S1, S2	SPST	Tactile & Jog Switches 6x6 260gf RED SMT	Mountain Switch	101-TS6923T2605-EV
TH1	10k	NTC Thermistor, 10k, 0402	Murata Electronics North America	NCP15XH103F03RC
U1	TC1262-3.3V	Linear Voltage Regulator	Microchip	TC1262-3.3VDBTR
U2	FT232RQ	IC USB FS SERIAL UART 32-QFN	FTDI	FT232RQ-REEL

RNXV Evaluation Kit User's Guide

A.5 RN-XV-EK1 PHYSICAL DIMENSIONS

Figure A-7 shows the physical dimensions of the RN-XV-EK1 evaluation board.

FIGURE A-7: RN-XV-EK1 PHYSICAL DIMENSIONS

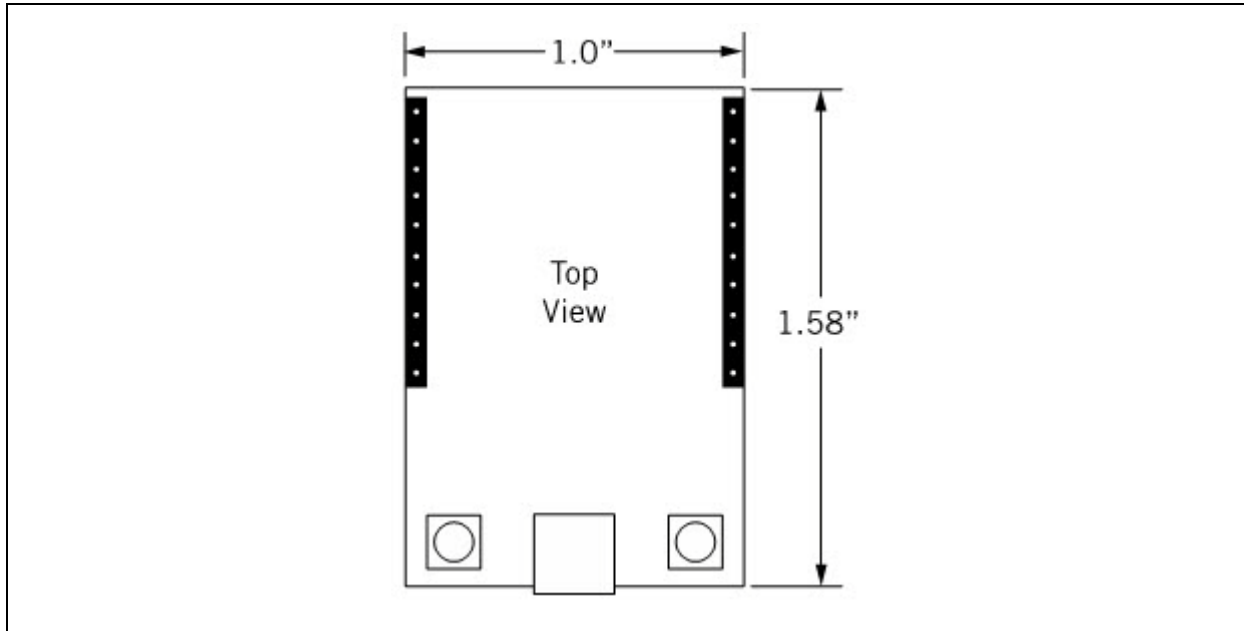



MICROCHIP

Worldwide Sales and Service

AMERICAS

Corporate Office
2355 West Chandler Blvd.
Chandler, AZ 85224-6199
Tel: 480-792-7200
Fax: 480-792-7277
Technical Support:
<http://www.microchip.com/support>
Web Address:
www.microchip.com

Atlanta
Duluth, GA
Tel: 678-957-9614
Fax: 678-957-1455

Austin, TX
Tel: 512-257-3370

Boston
Westborough, MA
Tel: 774-760-0087
Fax: 774-760-0088

Chicago
Itasca, IL
Tel: 630-285-0071
Fax: 630-285-0075

Cleveland
Independence, OH
Tel: 216-447-0464
Fax: 216-447-0643

Dallas
Addison, TX
Tel: 972-818-7423
Fax: 972-818-2924

Detroit
Novi, MI
Tel: 248-848-4000

Houston, TX
Tel: 281-894-5983

Indianapolis
Noblesville, IN
Tel: 317-773-8323
Fax: 317-773-5453

Los Angeles
Mission Viejo, CA
Tel: 949-462-9523
Fax: 949-462-9608

New York, NY
Tel: 631-435-6000

San Jose, CA
Tel: 408-735-9110

Canada - Toronto
Tel: 905-673-0699
Fax: 905-673-6509

ASIA/PACIFIC

Asia Pacific Office
Suites 3707-14, 37th Floor
Tower 6, The Gateway
Harbour City, Kowloon
Hong Kong
Tel: 852-2401-1200
Fax: 852-2401-3431

Australia - Sydney
Tel: 61-2-9868-6733
Fax: 61-2-9868-6755

China - Beijing
Tel: 86-10-8569-7000
Fax: 86-10-8528-2104

China - Chengdu
Tel: 86-28-8665-5511
Fax: 86-28-8665-7889

China - Chongqing
Tel: 86-23-8980-9588
Fax: 86-23-8980-9500

China - Hangzhou
Tel: 86-571-2819-3187
Fax: 86-571-2819-3189

China - Hong Kong SAR
Tel: 852-2943-5100
Fax: 852-2401-3431

China - Nanjing
Tel: 86-25-8473-2460
Fax: 86-25-8473-2470

China - Qingdao
Tel: 86-532-8502-7355
Fax: 86-532-8502-7205

China - Shanghai
Tel: 86-21-5407-5533
Fax: 86-21-5407-5066

China - Shenyang
Tel: 86-24-2334-2829
Fax: 86-24-2334-2393

China - Shenzhen
Tel: 86-755-8864-2200
Fax: 86-755-8203-1760

China - Wuhan
Tel: 86-27-5980-5300
Fax: 86-27-5980-5118

China - Xian
Tel: 86-29-8833-7252
Fax: 86-29-8833-7256

China - Xiamen
Tel: 86-592-2388138
Fax: 86-592-2388130

China - Zhuhai
Tel: 86-756-3210040
Fax: 86-756-3210049

ASIA/PACIFIC

India - Bangalore
Tel: 91-80-3090-4444
Fax: 91-80-3090-4123

India - New Delhi
Tel: 91-11-4160-8631
Fax: 91-11-4160-8632

India - Pune
Tel: 91-20-3019-1500

Japan - Osaka
Tel: 81-6-6152-7160
Fax: 81-6-6152-9310

Japan - Tokyo
Tel: 81-3-6880-3770
Fax: 81-3-6880-3771

Korea - Daegu
Tel: 82-53-744-4301
Fax: 82-53-744-4302

Korea - Seoul
Tel: 82-2-554-7200
Fax: 82-2-558-5932 or
82-2-558-5934

Malaysia - Kuala Lumpur
Tel: 60-3-6201-9857
Fax: 60-3-6201-9859

Malaysia - Penang
Tel: 60-4-227-8870
Fax: 60-4-227-4068

Philippines - Manila
Tel: 63-2-634-9065
Fax: 63-2-634-9069

Singapore
Tel: 65-6334-8870
Fax: 65-6334-8850

Taiwan - Hsin Chu
Tel: 886-3-5778-366
Fax: 886-3-5770-955

Taiwan - Kaohsiung
Tel: 886-7-213-7830

Taiwan - Taipei
Tel: 886-2-2508-8600
Fax: 886-2-2508-0102

Thailand - Bangkok
Tel: 66-2-694-1351
Fax: 66-2-694-1350

EUROPE

Austria - Wels
Tel: 43-7242-2244-39
Fax: 43-7242-2244-393

Denmark - Copenhagen
Tel: 45-4450-2828
Fax: 45-4485-2829

France - Paris
Tel: 33-1-69-53-63-20
Fax: 33-1-69-30-90-79

Germany - Dusseldorf
Tel: 49-2129-3766400

Germany - Munich
Tel: 49-89-627-144-0
Fax: 49-89-627-144-44

Germany - Pforzheim
Tel: 49-7231-424750

Italy - Milan
Tel: 39-0331-742611
Fax: 39-0331-466781

Italy - Venice
Tel: 39-049-7625286

Netherlands - Drunen
Tel: 31-416-690399
Fax: 31-416-690340

Poland - Warsaw
Tel: 48-22-3325737

Spain - Madrid
Tel: 34-91-708-08-90
Fax: 34-91-708-08-91

Sweden - Stockholm
Tel: 46-8-5090-4654

UK - Wokingham
Tel: 44-118-921-5800
Fax: 44-118-921-5820

10/28/13