

# Selecting the Right Sense Resistor for Motor Control with Reinforced Isolation

## WHITE PAPER

*By: Cathal Sheehan, Bourns Electronics, Ireland  
Nicola O'Byrne, Analog Devices, Ireland*



CST0612



CSS2H-2512



CSS2H-3920



CSS2H-5930



CSS4J-4026R

### INTRODUCTION

The use of current sense resistors is part of a trend in motor control system design that benefits from adopting new digital isolation technologies. These technologies offer higher reliability levels to designers based on the introduction of the component level standard IEC 60747-17, which specifies the performance, test and certification requirements for capacitive and magnetically coupled isolators. Digital isolation offers other benefits such as faster loop responses allowing for integrated overcurrent protection as well as narrower dead times. This enables smoother output voltages, which in turn provide better control of torque. This paper presents a summary of the differences in standards between traditional opto-coupler-based technologies and inductive/capacitive technologies for reinforced isolation. It also provides an overview of a system using digital control of a motor drive that incorporates current sense resistors for sensing winding current. The paper will offer recommendations for selecting the best current sense resistor for this application.

# Selecting the Right Sense Resistor for Motor Control with Reinforced Isolation

## UPDATE ON STANDARDS FOR ISOLATION AS APPLIED TO MOTOR DRIVES

Designers of motor drives are most likely aware of the need to comply with international standards for isolation. Isolation is necessary for a number of reasons:

- Prevents electrical noise from the ground connection of a high power circuit being induced onto a low power signal line.
- Provides electrical safety for end users by preventing dangerous voltages and currents from transferring to a benign low voltage environment.

The IEC 61010-1, Edition 3 standard specifies that the system level designer must be aware of the distances between conductors through air (clearance) and over surfaces (creepage). It also stipulates they must know the separation between conductors and metallic parts in potting, and molding compounds as well as thin film insulation. A designer should ensure that the chosen components guarantee a certain level of safety if they are being used on systems compliant to IEC 61010-1. According to the standard IEC 60747-17, the reinforced isolation is tested using the industry-accepted Time Dependent Dielectric Breakdown (TDDB) analysis, which then helps to extrapolate the device's lifespan and continuous working voltage (VIORM).

While IEC 60747-17 (VDE0884-10 Ed 2) was adopted to specifically define insulation using inductive and capacitive technologies, the well-established IEC 60747-5-5 standard was used to define the insulation using opto-coupler technologies. However, IEC 60747-5-5 does not specify the TDDB analysis to determine the continuous working voltage or lifetime. It relies on the Partial Discharge (PD) voltage test to establish the working voltage but does not define the working lifetime of the device. Hence, inductive and capacitive technologies have a minimum rated lifetime of 37.44 years while there is no definition for opto-coupler-based isolators.

The following table summarizes the key differences between opto-coupler and non opto-coupler-based standards. The conclusion is that non opto-coupler-based standards will gain more acceptance over time as they offer greater security to design engineers and longer operating lifespans.

Table 1. | Key Differences Between Opto-coupler and Non Opto-coupler-based Isolation

Specification	VDE 0884-10 Ed 2 Basic Isolation	Reinforced Isolation	IEC 60747-5-5 Reinforced Only
Partial Discharge Test	1.5 x VIORM	1.875 x VIORM	1.875 x VIORM
Working Voltage (VIORM)	Based on TDDB Analysis	Based on TDDB Analysis	Based on PD Test
Minimum Rated Lifetime	26 Years	37.5 Years	Not Defined
Failure Rate over Lifetime	1000 ppm	1 ppm	Not Defined



CST0612



CSS2H-2512



CSS2H-3920



CSS2H-5930



CSS4J-4026R

# Selecting the Right Sense Resistor for Motor Control with Reinforced Isolation

## TYPICAL SYSTEM WITH REINFORCED ISOLATION USING SENSE RESISTORS

Figure 1 shows a typical three-phase permanent magnet motor drive using sense resistors for measuring the winding current, and with feedback through Analog Devices' AD7403 isolated sigma delta modulator and iSinc<sup>3</sup> filter. The AD7403 uses a single-second order modulator digitizing circuit that converts the analog signal from the sense resistor into an isolated single bit pulse stream, which scales according to the full scale input voltage range. The Sinc<sup>3</sup> filter then extracts the average value of the current while eliminating noise created by inverter switching. It can store a 16-bit integer representing the current in memory, and at the same time, it can compare the number with a reference representing current limits and send an alert via a separate pin during overload conditions. The use of shorter filters for overload monitoring in parallel with the measurement filter allows alert latencies to be reduced.

The AD7403 has reinforced isolation allowing the current sense resistor voltage to be measured directly by the modulator with no extra components apart from a simple discrete low pass filter comprising of a resistor and capacitor. The specified maximum operating voltage of the modulator is  $\pm 250$  mV, which requires that the resistance value of the current sense resistor to be less than  $250 \text{ mV}/I_{\text{max}}$ .

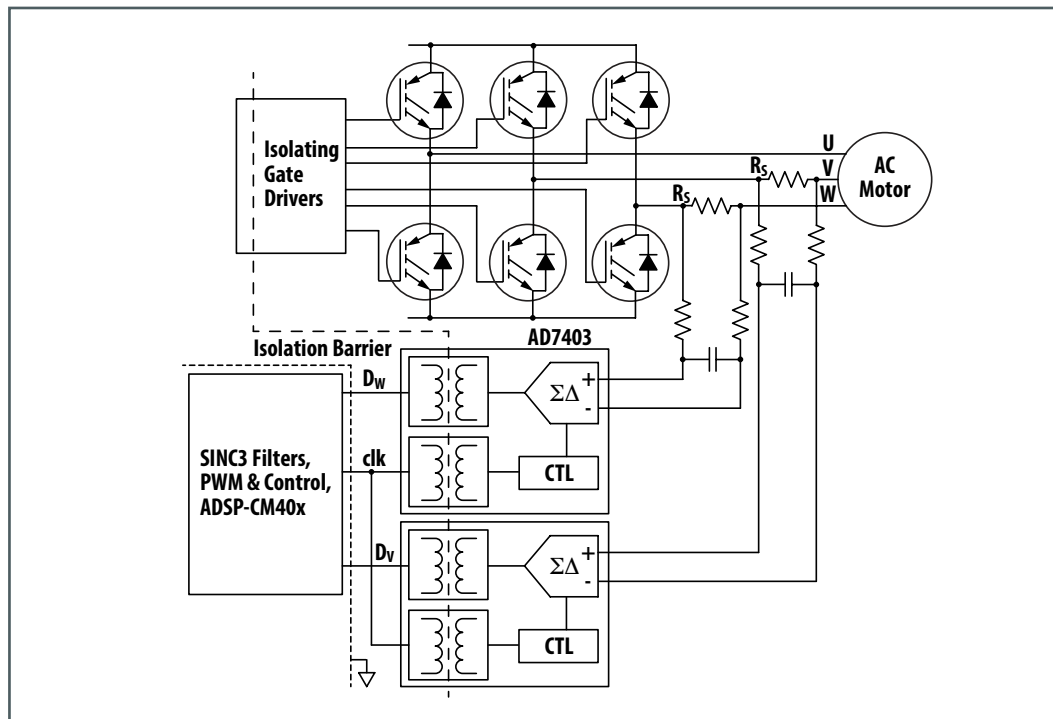

Figure 1. Block Diagram of Three-phase Motor Drive with Digital Isolation and Sense Resistors

# Selecting the Right Sense Resistor for Motor Control with Reinforced Isolation

## CONSIDERATIONS IN SELECTING THE RIGHT SENSE RESISTOR

### Resistance Drift with Temperature

Given that the output of the AD7403 is a 16-bit number, the potential accuracy of the current measurement is limited not by the A/D conversion but by the voltage reading itself. The drift of the resistance with temperature will vary depending on the material used in the resistor element as well as the power rating and the actual physical size of the component.

Resistive elements made up of special alloys of nickel, copper and manganese have parabolic resistance drift curves as shown in Figure 2. These alloys are the most accurate materials used for current sensing applications. Figure 2 also shows the upper and lower limits of resistance drift of Bourns® Model CSS4J-4026R corresponding to a temperature coefficient of 50 ppm/°C. This gap is caused by the copper terminals of the resistor, which increase drift due to the high TCR of copper (4000 ppm/°C). The Bourns® Model CST0612 series is a 1 watt, 4-terminal resistor made from a special alloy. It measures 3.2 x 1.65 mm, has a TCR of  $\pm 100$  ppm/°C and the difference in TCR between Bourns® Model CST0612 and Model CSS4J-4026R can be explained by the proportion of copper with respect to the resistive element. The additional copper with its low thermal resistance helps the component absorb the high power without overheating. This example demonstrates the trade-off between the size of the component, the power rating and the drift in the resistance value overtemperature.



CST0612



CSS2H-2512



CSS2H-3920



CSS2H-5930



CSS4J-4026R

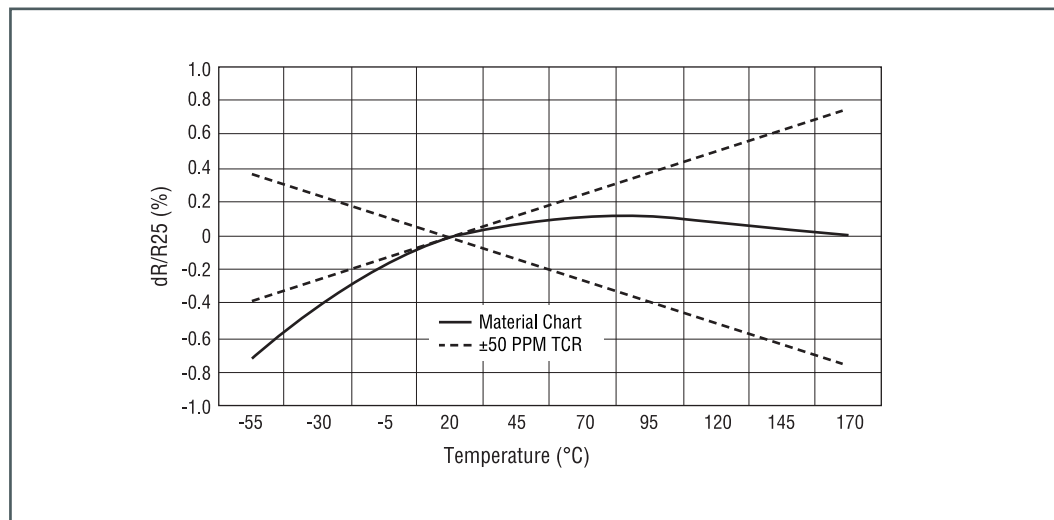

Figure 2. Parabolic TCR Curve of Bourns® Model CSS4J-4026R Current Sense Resistor

# Selecting the Right Sense Resistor for Motor Control with Reinforced Isolation

## CONSIDERATIONS IN SELECTING THE RIGHT SENSE RESISTOR (*Continued*)

### Resistance Drift Calculation

Let us use Bourns® Model CSS4J-4026R-L500F for calculating the resistance drift at full power and at an ambient temperature of 70 °C. The Model CSS4J-4026R-L500F is a 0.5 mΩ (±1 %) sense resistor rated to 5 watts of power at a maximum ambient temperature of 130 °C. It derates from 100 % power to 0 watts at 170 °C. The thermal resistance of the component, therefore, is 8 °C/W. At full power and an ambient temperature of 70 °C, the surface temperature of the component can be expected to reach 110 °C (70 °C + 8 x 5 °C). The drift in resistance at 110 °C can be taken from Figure 2 which is +0.45 % of the nominal value at 25 °C. The absolute tolerance is ±1 % and, therefore, the accuracy of the current measurement will be a maximum of +1.45 %.

### Overloads

Motor drives will experience short circuits from time to time and the current sense resistor must be able to handle short overloads without being damaged. Using the Bourns® Model CST0612 current sense resistor as an example, it is possible to calculate the mass of this component, from the material declaration sheet on the Bourns website, at 0.0132 g. Alternatively, it can be calculated from the dimensions and the density of copper and alloys (8.4 g/cm<sup>3</sup>). The rate of rise of temperature can be calculated by the following:

$$\frac{dT}{dt} = \frac{P}{mC}$$

Where P is power (watts), m is the mass of the component (g) and C is the specific heat capacity of the metal alloy.

An overload of 50 amps in a resistance of 1 milliohm would create a 462 °C per second temperature slew rate. Assuming a steady state temperature of 50 °C, the width of the short circuit period cannot exceed 0.22 seconds. This can be extended by increasing the overall mass through copper plating on the circuit board.

A thicker, larger part such as Model CSS4J-4026 with a mass of 0.371 g would have a temperature slew rate of 16.5 °C/second given the same overload. Assuming the component had a surface temperature of 100 °C, it would handle the energy for up to four seconds before the surface temperature reached the maximum allowed value of 170 °C.



CST0612



CSS2H-2512



CSS2H-3920



CSS2H-5930



CSS4J-4026R

# Selecting the Right Sense Resistor for Motor Control with Reinforced Isolation

## CONSIDERATIONS IN SELECTING THE RIGHT SENSE RESISTOR *(Continued)*

### Appropriate Resistance Value

The AD7403 has a full scale input of  $\pm 250$  mV from the resistor. The following table outlines the voltage drop at maximum current across Bourns® high power current sense resistor models. The designer can compensate for lower voltages by adjusting the scaling factor.



CST0612



CSS2H-2512



CSS2H-3920



CSS2H-5930



CSS4J-4026R

Table 2. | Bourns® Current Sense Resistors

Resistor Family	Maximum Current (Lowest Resistance)	Voltage at Maximum Current
CST0612	44.7 A	22.3 mV
CSS2H-2512	140 A	42.4 mV
CSS2H-3920	245 A	49 mV
CSS2H-5930	126.5 A	63 mV
CSS4J-4026R	100 A	50 mV

### CONCLUSION

According to IEC 60747-17, the minimum lifetime of a digital isolator rated to reinforced isolation should be 37.5 years, while there is no such reference for more traditional opto-coupler technologies. The standard will help designers feel more confident about working with digitally isolated systems in the future. Current sense resistors manufactured using special alloys have low resistance drift over temperature and produce output voltages which can be read with an adjustable scaling factor by an isolated sigma-delta modulator such as those using Analog Devices iCoupler® technology. The accuracy of the current measurement will depend on the temperature of the resistor which in turn depends on the power as a proportion of the power rating as well as the ambient temperature.

# Selecting the Right Sense Resistor for Motor Control with Reinforced Isolation



CST0612



CSS2H-2512



CSS2H-3920



CSS2H-5930



CSS4J-4026R

## REFERENCES

[1] O'Byrne, Nicola Sigma Delta Modulators Improve Motion Control Efficiency Analog Devices Application Note

[2] O'Sullivan, Dara, Sorensen Jens, Murray Aengus Isolated Motor Control Feedback Using the ADSP-SM402F/ADSP-CM403F/ADSP-CM407F/ADSP-CM408F Sinc Filters and the AD7403 Analog Devices Application Note AN-1265

[3] Table Showing Differences in Norms Between Optocouplers and Magnetic and Capacitive Couplers VDE

## ADDITIONAL RESOURCES

This white paper was coauthored by:

Cathal Sheehan, Bourns Electronics, Ireland: [Cathal.Sheehan@bourns.com](mailto:Cathal.Sheehan@bourns.com)

Nicola O'Byrne, Analog Devices, Ireland: [Nicola.OByrne@Analog.com](mailto:Nicola.OByrne@Analog.com)

For more information about Bourns' complete product line, please visit:

[www.bourns.com](http://www.bourns.com)

**Americas:** Tel +1-951 781-5500  
Email [americus@bourns.com](mailto:americus@bourns.com)

**EMEA:** Tel +36 88 520 390  
Email [eurocus@bourns.com](mailto:eurocus@bourns.com)

**Asia-Pacific:** Tel +886-2 256 241 17  
Email [asiacus@bourns.com](mailto:asiacus@bourns.com)