

2-POST OPEN FRAME RACK

Two-Post Rack with shelves

Populated Two-Post Rack with vertical cable management

INDUSTRY STANDARDS

 UL 2416 Listed; File No. E230874
 cUL Listed per CSA C22.2 No. 182.4; File No. E230874

EIA 310-D

APPLICATION

Designed for use in network, server, and telecommunication rooms, 2-Post Open Frame Racks satisfy basic functional requirements for structuring cable. Racks are available in 3-in. or 6-in. column widths.

FEATURES

- Range of heights from 4 ft. to 9 ft. (24U to 58U) to match capacity requirements; 19-in. Rack Packages are 7-ft. high
- Side rails are tapped on both sides with 12-24UNC threads for quick installation
- EIA Universal 5/8 in. - 5/8 in. - 1/2 in. vertical mounting hole pattern matches industry standards
- RU markings on both front and back of uprights make it easier to mount equipment
- Packed unassembled in individual cartons; assembly hardware (including twenty 12-24 mounting screws) is furnished for convenient storage and installation
- Convenient rack and cable manager packages offered with either one or two 6-in. cable managers; includes one-piece hinged cover

SPECIFICATIONS

- Frame is a strong and lightweight aluminum (6063-T6 alloy), extruded or formed, with RU markings on both front and back of uprights

FINISH

RAL 9005 black polyester powder paint or milled aluminum

LOAD RATING

Do not exceed the following recommended load ratings.

- Floor Mount Rack - 1000 lb. (453.6 kg)
- One-Sided Solid Shelf - 150 lb. (68.0 kg)
- Double-Sided Shelf - 300 lb. (136.1 kg)
- One-Sided Vented Shelf - 150 lb. (68.0 kg)
- Double-Sided Vented Shelf - 300 lb. (136.1 kg)
- Adjustable Vented Shelf - 60 lb. (27.2 kg)
- Keyboard/Monitor Shelf - 200 lb. (90.7 kg)

BULLETIN: DMAX, DOFR2
Standard Product 3-in. Column

Catalog Number	AxBxC in.	AxBxC mm	Description	Finish	Rack Units	Nominal Frame Height
EDR19FM24U	48.00 x 20.25 x 15.00	1219 x 514 x 381	19-in. rack	Black	24	4 ft.
EDR19FM38U	72.00 x 20.25 x 15.00	1829 x 514 x 381	19-in. rack	Black	38	6 ft.
EDR19FM45U	84.00 x 20.25 x 15.00	2134 x 514 x 381	19-in. rack	Black	45	7 ft.
EVR19FM45U	84.00 x 20.25 x 15.00	2134 x 514 x 381	19-in. rack	Mill	45	7 ft.
EDR19FM51U	96.00 x 20.25 x 15.00	2438 x 514 x 381	19-in. rack	Black	51	8 ft.
EVR19FM51U	96.00 x 20.25 x 15.00	2438 x 514 x 381	19-in. rack	Mill	51	8 ft.
EDR19FM58U	108.00 x 20.25 x 15.00	2743 x 514 x 381	19-in. rack	Black	58	9 ft.
EVR19FM58U	108.00 x 20.25 x 15.00	2743 x 514 x 381	19-in. rack	Mill	58	9 ft.
EDR23FM24U	48.00 x 24.25 x 15.00	1219 x 616 x 381	23-in. rack	Black	24	4 ft.
EDR23FM38U	72.00 x 24.25 x 15.00	1829 x 616 x 381	23-in. rack	Black	38	6 ft.
EDR23FM45U	84.00 x 24.25 x 15.00	2134 x 616 x 381	23-in. rack	Black	45	7 ft.
EVR23FM45U	84.00 x 24.25 x 15.00	2134 x 616 x 381	23-in. rack	Mill	45	7 ft.
EDR23FM51U	96.00 x 24.25 x 15.00	2438 x 616 x 381	23-in. rack	Black	51	8 ft.
EVR23FM51U	96.00 x 24.25 x 15.00	2438 x 616 x 381	23-in. rack	Mill	51	8 ft.

Standard Product 3-in. Column with Cable Manager

Catalog Number	AxBxC in.	AxBxC mm	Description	Finish	Rack Units	Nominal Frame Height
EDR19FM45UCM1	84.00 x 27.50 x 18.00	2134 x 699 x 457	19-in. rack package, 1 cable manager, DV6D7	Black	45	7 ft.
EDR19FM45UCM2	84.00 x 34.75 x 18.00	2134 x 883 x 457	19-in. rack package, 2 cable managers, DV6D7/	Black	45	7 ft.

Standard Product 6-in. Column

Catalog Number	AxBxC in.	AxBxC mm	Description	Finish	Rack Units	Nominal Frame Height
EDR19FM45U6	84.00 x 20.28 x 18.00	2134 x 515 x 457	19-in. rack	Black	45	7 ft.
EDR19FM51U6	96.00 x 20.28 x 18.00	2438 x 515 x 457	19-in. rack	Black	51	8 ft.

2-Post Rack Package
(CABLETEK Vertical Cable Managers shown with alternate mounting location)

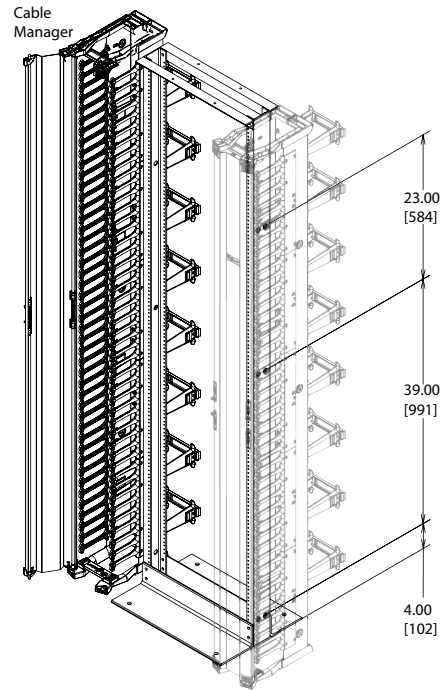
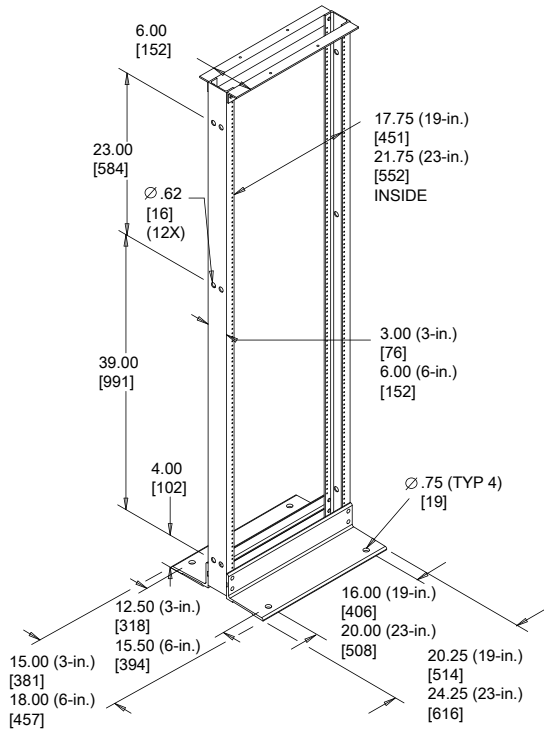

19-in. Shelf Depths

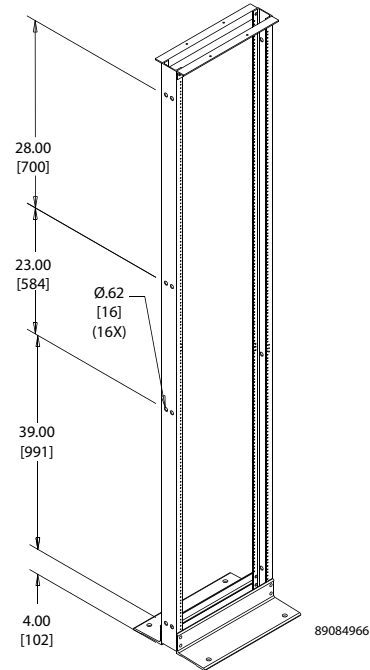
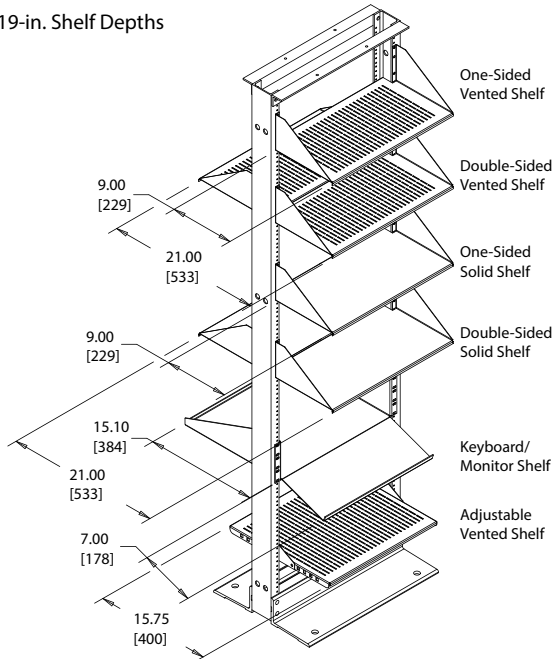

8-Foot and 9-Foot Racks Only
(Width and Depth dimensions identical to 7-foot rack)

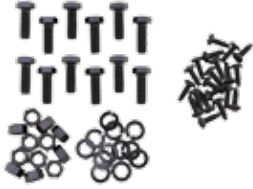
2-POST OPEN FRAME RACK HARDWARE KIT

Kit consists of (12) 3/8-16x1.00 hex head screws; (12) 3/8 split washers; and (12) 3/8-16 hex nuts.

BULLETIN: DOFRY

Standard Product

Catalog Number	Description
E2PKIT	2-Post Open Frame Rack hardware kit

CONCRETE EXPANSION BOLT ANCHOR KIT

BULLETIN: DACCY

Standard Product

Catalog Number	Description
ESBDK	(4) 3/8x3.75 expansion bolt kit

Notes