

# MCM AUDIO SELECT™

## SPEAKER SPECIFICATIONS

Model Number:	55-2974	
<b>GENERAL SPECIFICATIONS</b>		
Nominal Diameter:	15 inch	
Rated Impedance:	8 ohms	
Operating Bandwidth:	50-3k hz (-3dB)	
Power Handling Capacity:	200 Watts	
Sensitivity (1W/M):	92 dB(+3dB)	
Voice Coil Diameter:	2 inch	
<b>THIELE-SMALL PARAMETERS</b>		
Resonance Frequency	Fs:	32.5 HZ
DC Resistance	Re:	7.2 ohm
Mechanical Q Factor	Qms:	3.0845
Electrical Q Factor	Qes:	0.5591
Total Q Factor	Qts:	0.4733
Equivalent Cas air load	Vas:	322.23 L
Surface Area of Cone	Sd:	0.0840 m <sup>2</sup>
Efficiency Bandwidth Product	EBP	58
Voice Coil Over Hang	X-max	6 mm
Voice Coil Inductance	Le	1.522mH
<b>PHYSICAL INFORMATION</b>		
Basket:	Pressed steel chassis	
Magnet Type:	40 OZ	
Cone Material:	PP	
Surround:	Rubber	
Dust Cap:	PP	
Damper:	cloth	

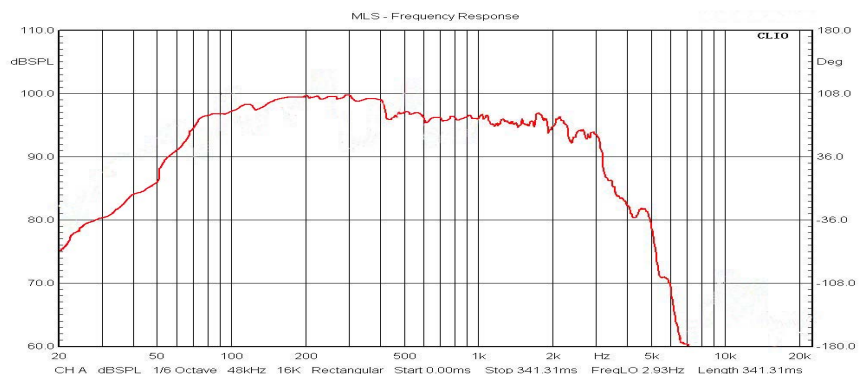
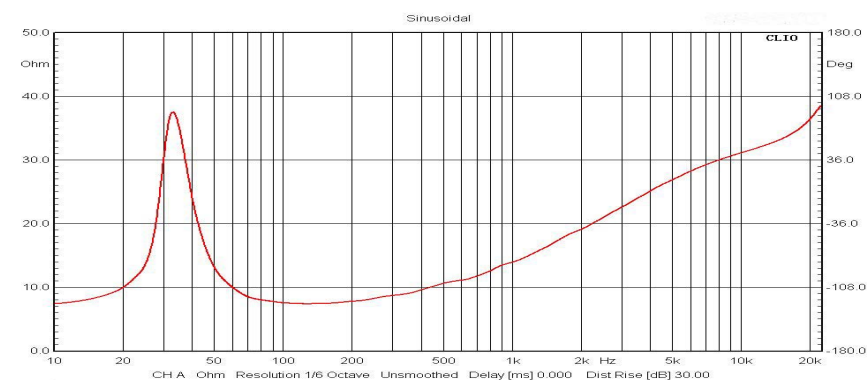

Date: 2010/6/28

## Impedance Curve

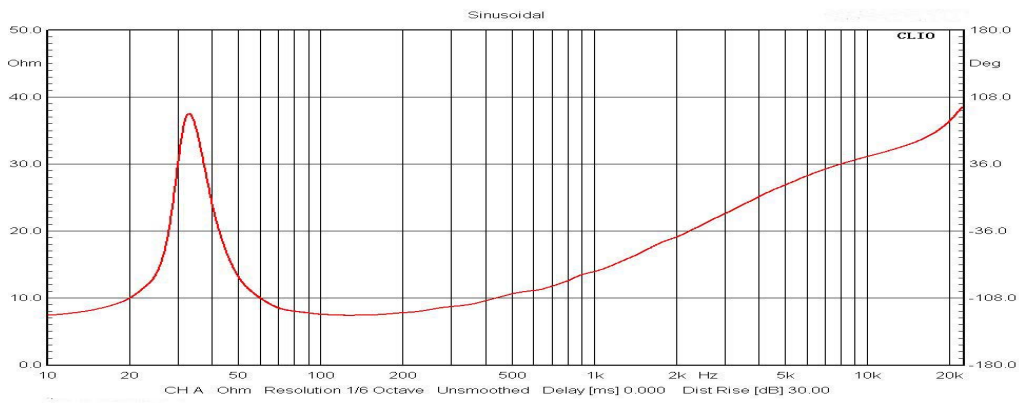

## Response Curve

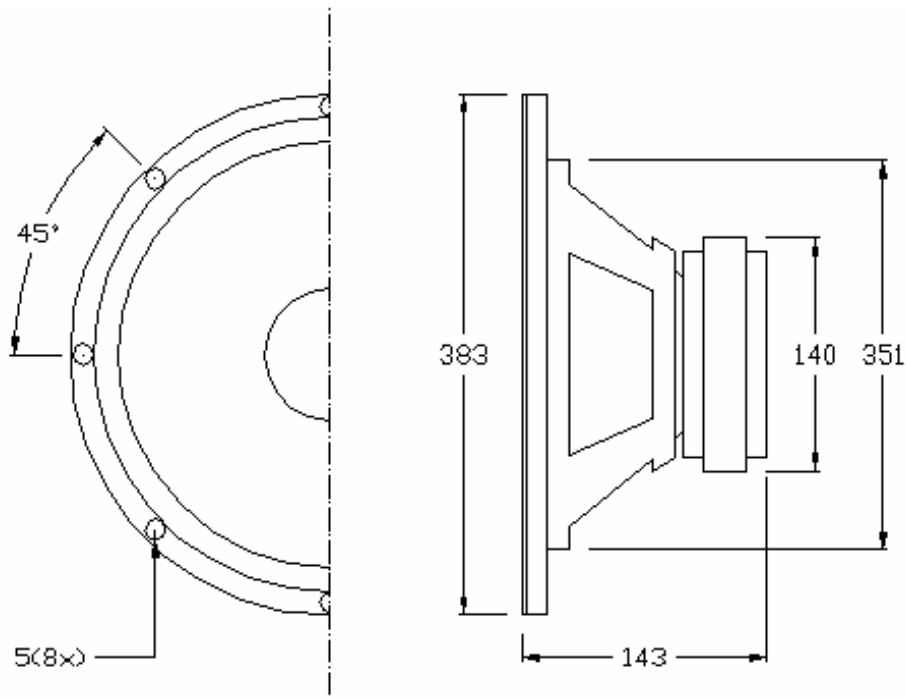
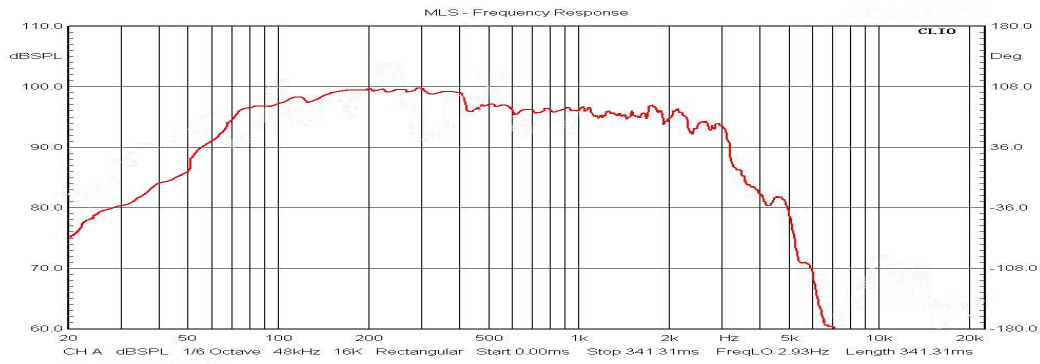

55-2974