

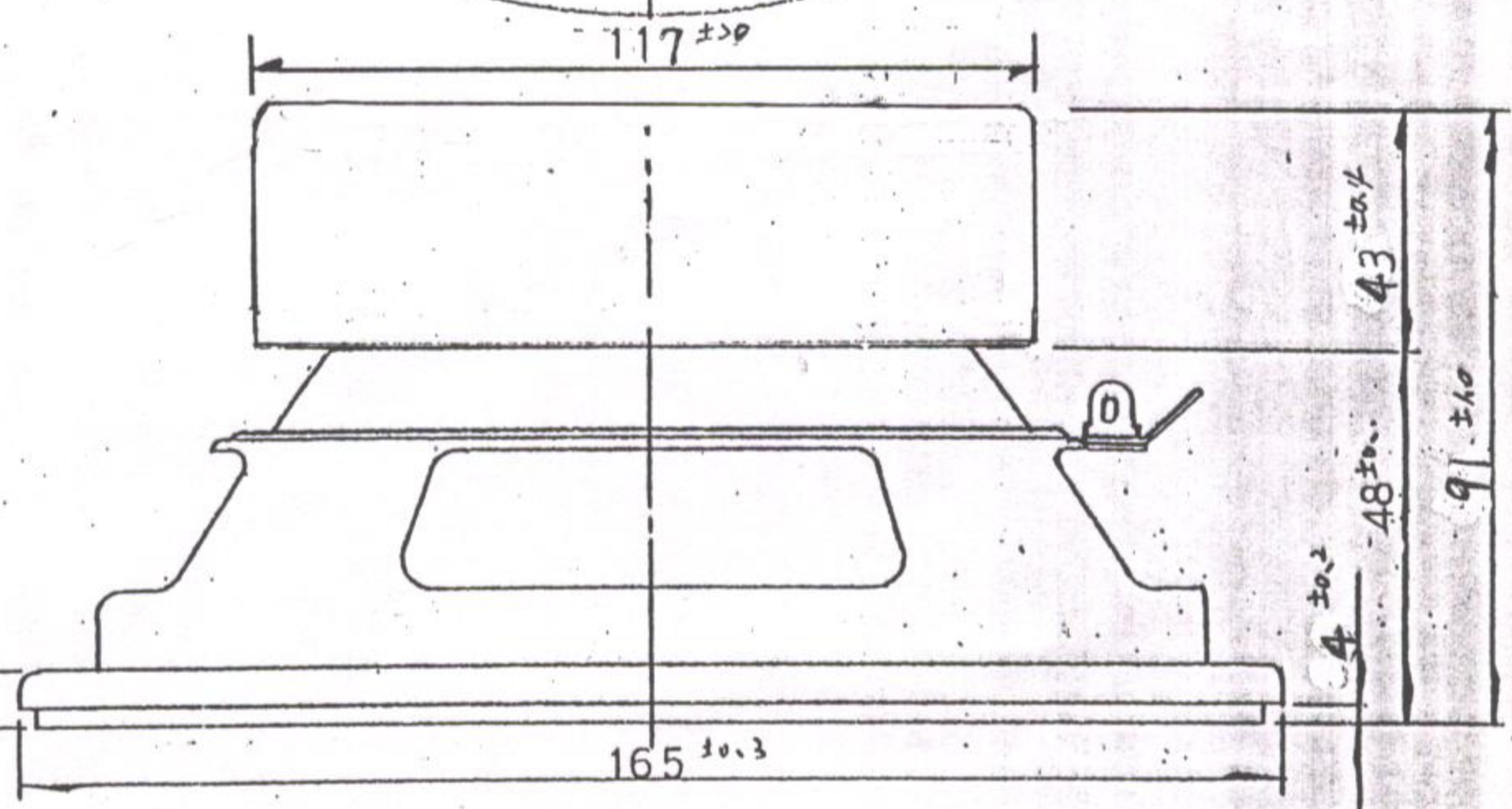

111111	80	75	90	110	130	160	190	220	250	290	320	360	400
111212	100	120	150	180	210	250	300	350	400	460	520	580	630
111313	140	180	220	270	330	390	460	540	630	720	810	900	970
111414	250	300	360	430	520	620	740	870	1000	1150	1300	1450	1550
111515	400	480	580	700	840	1000	1200	1400	1600	1850	2100	2300	2500

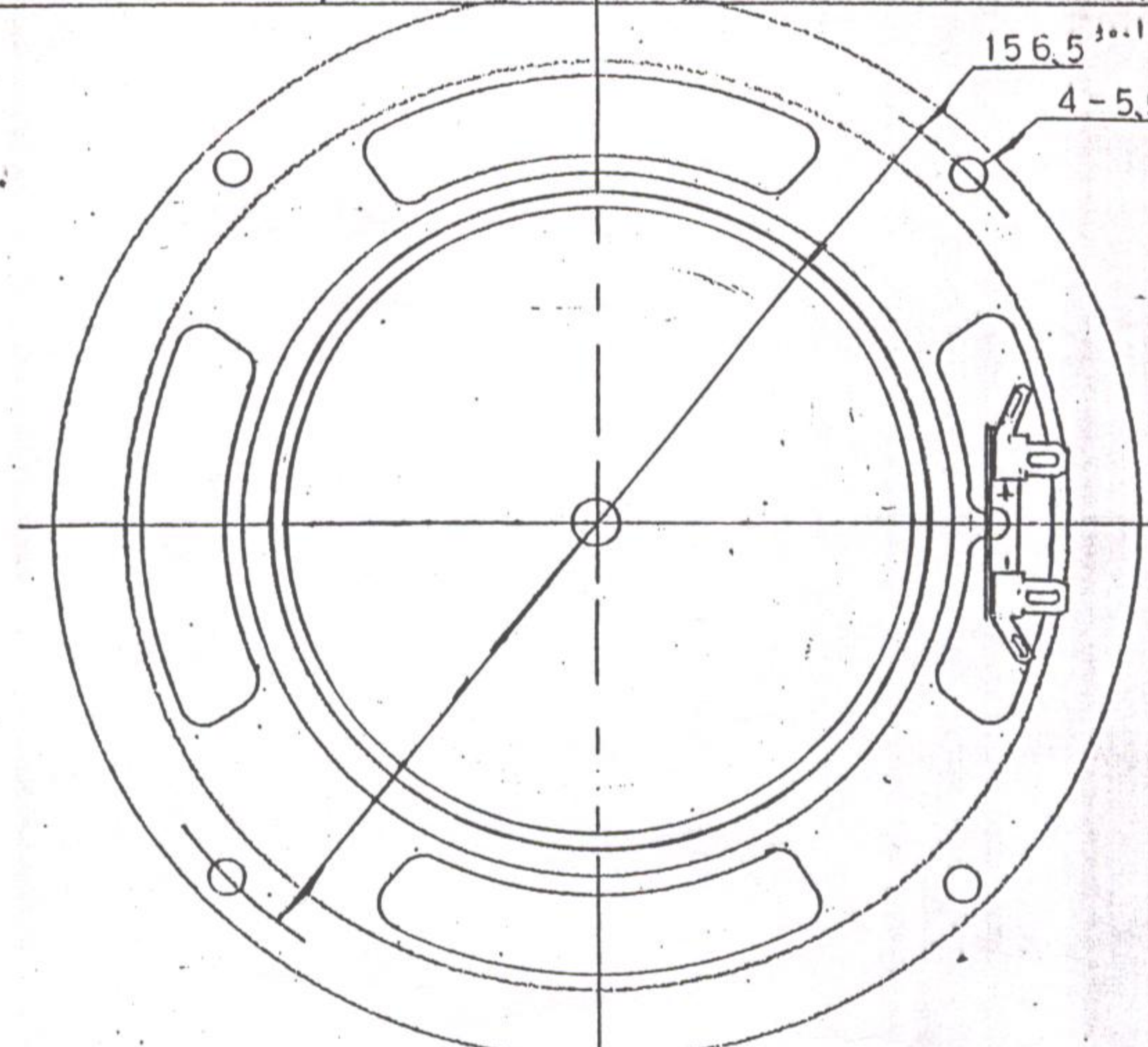

APVD.  
光  
CHK.  
Gan

一般公差		MATERIAL	SCALE 1/8	QUANTITY
DSGN.		FINISH	TOLERANCE ±	ANGLE ±
DR.		TITLE 6 1/2" SPEAKER		
1 初版 發行		Drawing 55-1860, 55-1862		
REV.	REVISIONS	DATE	DRAWING NO.	