

CUSTOMER MCM FILE NO. 26-700,705

THIS DRAWING AND SPECIFICATIONS HEREIN ARE THE CONFIDENTIAL PROPERTY OF SAMAR AND SHALL NOT BE REPRODUCED OR COPIED OR DISCLOSED IN WHOLE OR IN PART WITHOUT WRITTEN PERMISSION.

| REV. | DESCRIPTION     | DRAWN / DATE    | APPROVED / DATE |
|------|-----------------|-----------------|-----------------|
| 0    | INITIAL RELEASE | YANG 09/25/2003 |                 |

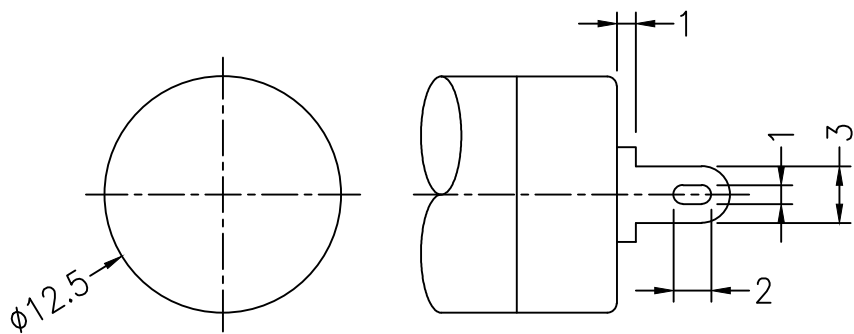
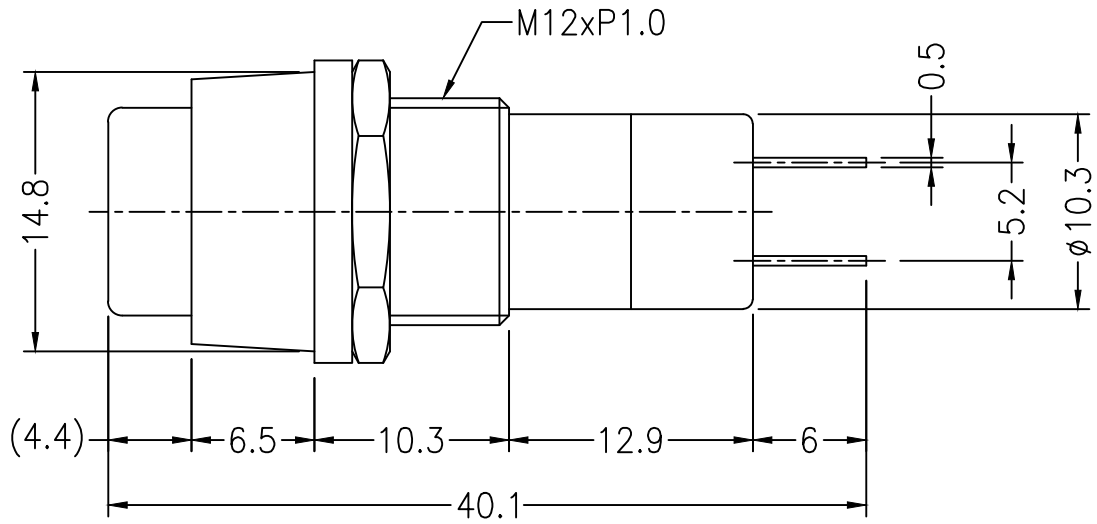
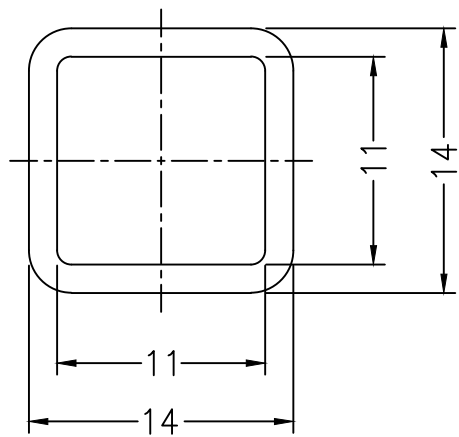

Panel Thickness  
5.0mm Max.

| P/N    | COLOR |
|--------|-------|
| 26-700 | BALCK |
| 26-705 | RED   |

SPECIFICATION:

1. Push button switch: SPST, push-on / spring-off
2. Rating: AC 125V 3A
3. Contact resistance: 50m Ohm Max.
4. Insulation resistance: DC500V 100M Ohm Min.
5. Dielectric Strength: AC 1500V 1 minute
6. Electrical Life: 20,000 make and break cycles at full load

PUSH BUTTON SWITCH