

Speed Sensors

1GT Series Gear Tooth Sensors

32315204

Issue A

Datasheet

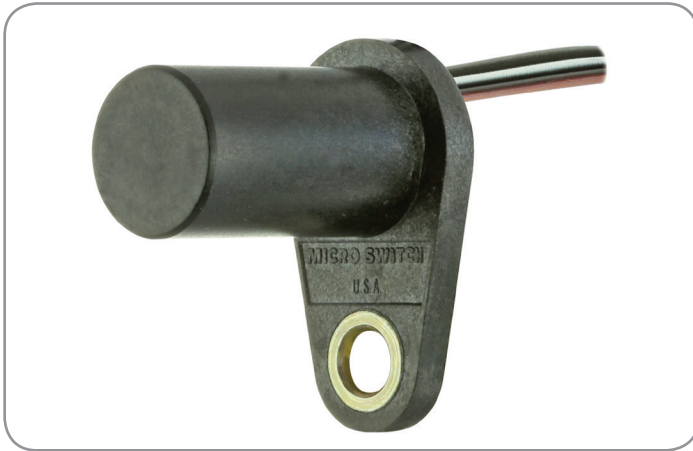

DESCRIPTION

The 1GT Series Gear Tooth Sensors use a magnetically biased Hall-effect integrated circuit (IC) to accurately sense movement of ferrous metal targets. This specially designed IC, with discrete capacitor and bias magnet, is sealed in a probe-type package for physical protection and cost-effective installation. Units will function from a 4.5 to 24 Vdc power supply. Output is digital, current sinking (open collector). Reverse polarity protection is standard. If power is inadvertently wired backwards, the sensor will not be damaged. Built-in protection against pulsed transients to +60 V, -40 V is also included. Optimum sensor performance is dependent on the following four variables which must be considered in combination:

- Target material, geometry, and speed
- Sensor/target sensing air gap distance
- Ambient temperature
- Magnetic material in close proximity

VALUE TO CUSTOMERS

The 1GT Series electronically self adjusts to slight variations in runout and temperature, often simplifying installation and maintenance.

FEATURES

- Senses ferrous metal targets
- Digital current sinking output (open collector)
- Better signal-to-noise ratio than variable reluctance sensors (VRS), excellent low speed performance, output amplitude not dependent on RPM
- Sensor electronically self-adjusts to slight variations in runout and variations in temperature, simplifying installation and maintenance
- Operating frequency range of 50 Hz to 10 kHz
- EMI resistant
- Reverse polarity protection and transient protection (integrated into Hall-effect IC)
- Wide continuous operating temperature range of -40 °C to 150 °C [-40 °F to 302 °F], short term to 160 °C [320 °F]

POTENTIAL APPLICATIONS

Transportation

- Camshaft and crankshaft speed/position
- Transmission speed
- Tachometers
- Anti-skid/traction control

Industrial

- Sprocket speed
- Chain link conveyor speed and distance
- Stop motion detector
- High speed, low-cost proximity
- Tachometers, counters

PORTFOLIO

Honeywell's 1GT Series joins the SNG-Q Series, SNDH-T Series, SNDH-H Series, LCZ Series, and ZH10 Series Speed Sensors.

Speed Sensors

1GT Series Gear Tooth Sensors

Table 1. Electrical Specifications (All values measured using a 1 kOhm pull-up resistor.)

Characteristic	Condition	Parameter
Supply voltage	—	4.5 Vdc to 24 Vdc
Supply current	—	10 mA typ., 20 mA max.
Output voltage	output low	0.4 V max.
Vsat	low output	0.4 V max.
Output current	low output	10 µA
Output leakage current	high output	—
Operation: ^{1,2,3} operate ⁴ release ⁵	sensing air gap = 0,13 mm to 2,03 mm [0.0 in to 0.08 in], Vsupply = 4.5 Vdc to 24 Vdc, -40 °C to 150 °C [-40 °F to 302 °F], 10 rpm to 5000 rpm	3.3° ±1.25° 4.4° ±2.5°
Switching time: rise (10% to 90%) fall (90% to 10%)	— —	5 µs max. 1.0 µs max.
Operating frequency range	—	50 Hz to 10 kHz

¹See Table 6.

²Guaranteed with maximum external load capacitance of 550 pF.

³Based on the target shown in Figure 3; will vary with target geometry.

⁴Operate (degrees) is the angular distance from the leading edge of the tooth to the centerline of the sensor.

⁵Release (degrees) is the angular distance from the trailing edge of the tooth to the centerline of the sensor.

Table 2. Environmental Specifications

Characteristic	Parameter
Operating temperature (sensor only)	-40 °C to 150 °C [-40 °F to 302 °F]
Storage temperature	-40 °C to 150 °C [-40 °F to 302 °F]
EMI resistance	yes
Transient protection	+60 V, -40 V
Reverse polarity protection	yes

Table 3. Absolute Maximum Ratings

Characteristic	Parameter
Supply voltage	+30 Vdc continuous
Voltage externally applied to output	-0.5 to +30 (output high)
Output current	40 mA sinking
Operating temperature (sensor only)	-40 °C to 150 °C [-40 °F to 302 °F]
Storage temperature	-40 °C to 150 °C [-40 °F to 302 °F]

NOTICE

Absolute maximum ratings are the extreme limits that the device will withstand without damage to the device. However, the electrical and mechanical characteristics are not guaranteed as the maximum limits (above recommended operating conditions) are approached, nor will the device necessarily operate at absolute maximum ratings.

Table 4. Mechanical Specifications

Characteristic	Parameter
Leads: length material temperature rating	137,2 mm [5.40 in], 650 mm [25.6 in], 1500 mm [59.1 in]; see Figure 3. 22 gauge wire, crosslinked polyethylene insulation 135 °C [275 °F] max.

Speed Sensors

1GT Series Gear Tooth Sensors

Target Guidelines

Table 5 provides basic parameters to follow when an application is not restricted to a specific target. Any target that exceeds these dimensions may be sensed over the entire temperature range of -40 °C to 150 °C [-40 °F to 302 °F] with a sensing air gap up to 2,0 mm [0.080 in].

Table 5. Reference Target Dimensions¹

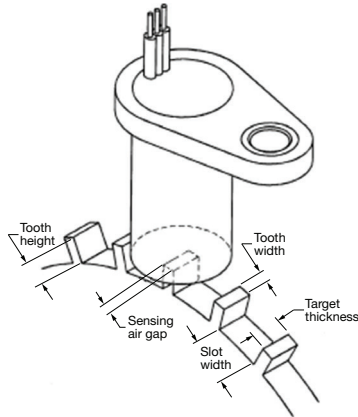

Characteristic	Parameter
Tooth height	5,06 mm [0.200 in] min.
Slot width	10,16 mm [0.400 in] min.
Tooth width	2,54 mm [0.100 in] min.
Target thickness	6,35 mm [0.250 in] min..

¹Based on a target diameter of 101,6 mm [4 in] at a rotation of 10 RPM to 3600 RPM.

Reference Target and Test Conditions (See Table 6)

Parameters will vary due to target size, geometry, location, and material.

Table 6. Reference Target Configuration and Evaluation Conditions^{1,2}

Characteristic	Parameter
Target diameter	101,6 mm [4 in] min.
Target thickness	6,35 mm [0.250 in]
Tooth width	8,89 in [0.350 in]

¹Reference target material is cold rolled steel.

²Test conditions are:

- Sensing air gap = 1,02 mm to 2,03 mm [0.040 in to 0.080 in]
- Vsupply = 4.5 Vdc to 24 Vdc.
- RPM = 10 RPM min. to 3600 RPM max.



Figure 1. Sensor Output Diagram with Sensor Output Diagram (with Pull-up Resistor Added to Output Circuit)

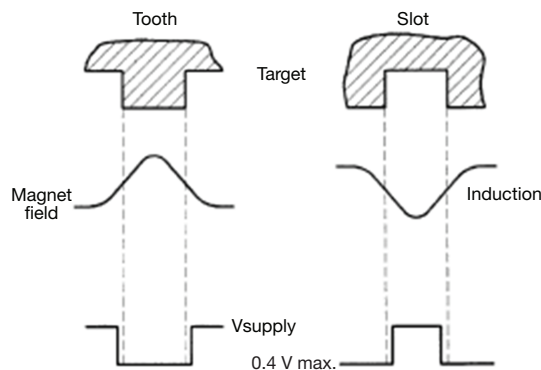
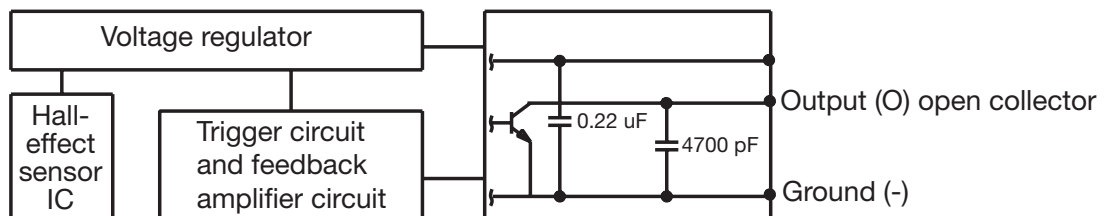

Figure 2. Block/Electrical Diagram



Speed Sensors

1GT Series Gear Tooth Sensors

Figure 3. Mounting Dimensions (For reference only. mm/[in].)

Catalog Listing	Lead Length "A"
1GT101DC	3X 137,2 mm [5.4 in]
1GT103DC	3X 650 mm [25.6 in]
1GT105DC	3X 1500 mm [59.1 in]

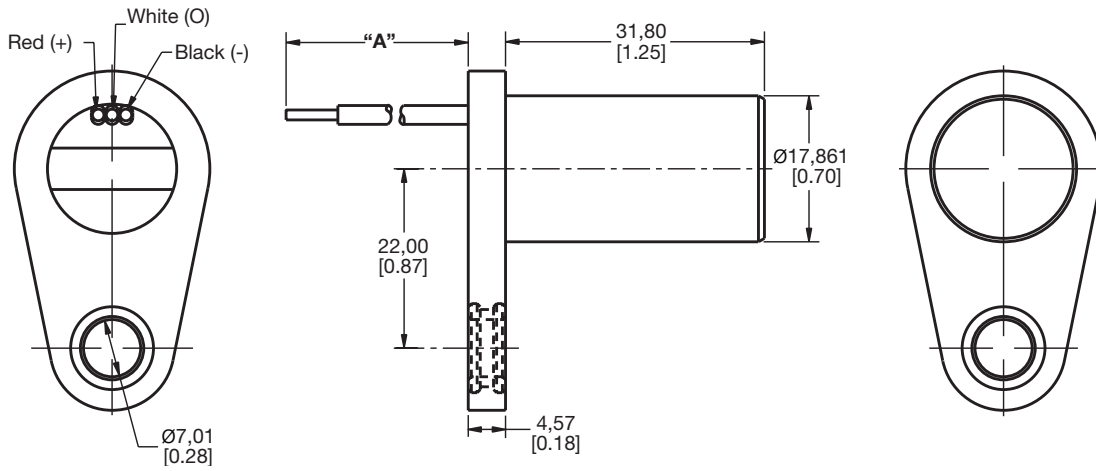

Table 7. Order Guide

Catalog Listing	Description
1GT101DC	1GT Series gear tooth sensor, 137,2 mm [5.4 in] lead length
1GT103DC	1GT Series gear tooth sensor, 650 mm [25.6 in] lead length
1GT105DC	1GT Series gear tooth sensor, 1500 mm [59.1 in] lead length

ADDITIONAL INFORMATION

The following associated literature is available on the Honeywell web site at sensing.honeywell.com:

- Magnetic Sensors Line Guide
- Position Sensors Range guide

⚠ WARNING **PERSONAL INJURY**

DO NOT USE these products as safety or emergency stop devices or in any other application where failure of the product could result in personal injury.

Failure to comply with these instructions could result in death or serious injury.

⚠ WARNING **MISUSE OF DOCUMENTATION**

- The information presented in this datasheet is for reference only. Do not use this document as a product installation guide.
- Complete installation, operation, and maintenance information is provided in the instructions supplied with each product.

Failure to comply with these instructions could result in death or serious injury.

Find out more

Honeywell serves its customers through a worldwide network of sales offices, representatives and distributors.

For application assistance, current specifications, pricing or name of the nearest Authorized Distributor, contact your local sales office.

To learn more about Honeywell Sensing and Productivity Solutions' products, call **+1-815-235-6847** or **1-800-537-6945**, visit **sensing.honeywell.com**, or e-mail inquiries to **info.sc@honeywell.com**

Sensing and Productivity Solutions
Honeywell
1985 Douglas Drive North
Golden Valley, MN 55422
honeywell.com

Warranty/Remedy

Honeywell warrants goods of its manufacture as being free of defective materials and faulty workmanship. Honeywell's standard product warranty applies unless agreed to otherwise by Honeywell in writing; please refer to your order acknowledgement or consult your local sales office for specific warranty details. If warranted goods are returned to Honeywell during the period of coverage, Honeywell will repair or replace, at its option, without charge those items it finds defective.

The foregoing is buyer's sole remedy and is in lieu of all other warranties, expressed or implied, including those of merchantability and fitness for a particular purpose. In no event shall Honeywell be liable for consequential, special, or indirect damages.

While we provide application assistance personally, through our literature and the Honeywell web site, it is up to the customer to determine the suitability of the product in the application.

Specifications may change without notice. The information we supply is believed to be accurate and reliable as of this printing. However, we assume no responsibility for its use.

Honeywell