



SOLID STATE INC.

46 FARRAND STREET
BLOOMFIELD, NEW JERSEY 07003

www.solidstateinc.com

**1N3909 thru 1N3913
MR1396**

**FAST RECOVERY
POWER RECTIFIERS**

50-600 VOLTS
30 AMPERES

**STUD MOUNTED
FAST RECOVERY POWER RECTIFIERS**

... designed for special applications such as dc power supplies, inverters, converters, ultrasonic systems, choppers, low RF interference, sonar power supplies and free wheeling diodes. A complete line of fast recovery rectifiers having typical recovery time of 150 nanoseconds providing high efficiency at frequencies to 250 kHz.



DO 5
(Metal)

***MAXIMUM RATINGS**

Rating	Symbol	1N3909	1N3910	1N3911	1N3912	1N3913	MR1396	Unit
Peak Repetitive Reverse Voltage Working Peak Reverse Voltage DC Blocking Voltage	V_{RRM} V_{RWM} V_R	50	100	200	300	400	600	Volts
Non-Repetitive Peak Reverse Voltage	V_{RSM}	75	150	250	350	450	650	Volts
RMS Reverse Voltage	$V_{R(RMS)}$	35	70	140	210	280	420	Volts
Average Rectified Forward Current (Single phase, resistive load, $T_C = 100^\circ\text{C}$)	I_O	← 30 →						Amps
Non-Repetitive Peak Surge Current (surge applied at rated load conditions)	I_{FSM}	← 300 →						Amp
Operating Junction Temperature Range	T_J	← -65 to +150 →						$^\circ\text{C}$
Storage Temperature Range	T_{stg}	← -65 to +175 →						$^\circ\text{C}$

THERMAL CHARACTERISTICS

Characteristic	Symbol	Max	Unit
Thermal Resistance, Junction to Case	$R_{\theta JC}$	1.2	$^\circ\text{C/W}$

***ELECTRICAL CHARACTERISTICS**

Characteristic	Symbol	Min	Typ	Max	Unit
Instantaneous Forward Voltage ($I_F = 93 \text{ Amp}$, $T_J = 150^\circ\text{C}$)	v_F	-	1.2	1.5	Volts
Forward Voltage ($I_F = 30 \text{ Amp}$, $T_C = 25^\circ\text{C}$)	V_F	-	1.1	1.4	Volts
Reverse Current (rated dc voltage) $T_C = 25^\circ\text{C}$ $T_C = 100^\circ\text{C}$	I_R	-	10 0.5	25 1.0	μA mA

***REVERSE RECOVERY CHARACTERISTICS**

Characteristic	Symbol	Min	Typ	Max	Unit
Reverse Recovery Time ($I_F = 1.0 \text{ Amp}$ to $V_R = 30 \text{ Vdc}$, Figure 16) ($I_{FM} = 36 \text{ Amp}$, $di/dt = 25 \text{ A}/\mu\text{s}$, Figure 17)	t_{rr}	-	150 200	200 400	ns
Reverse Recovery Current ($I_F = 1.0 \text{ Amp}$ to $V_R = 30 \text{ Vdc}$, Figure 16)	$I_{RM(REC)}$	-	1.5	2.0	Amp

*Indicates JEDEC Registered Data for 1N3909 Series.

1N3909 thru 1N3913, MR1396

FIGURE 1 – FORWARD VOLTAGE

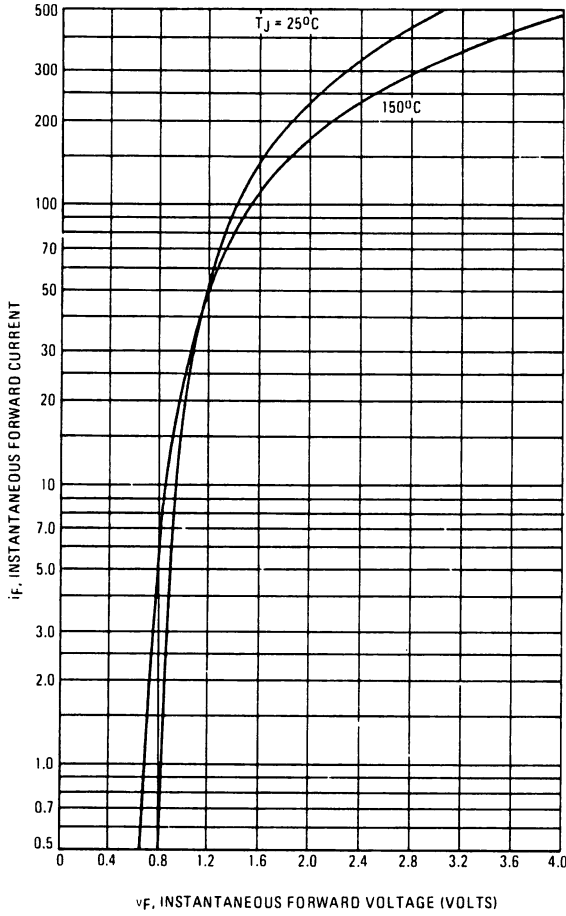
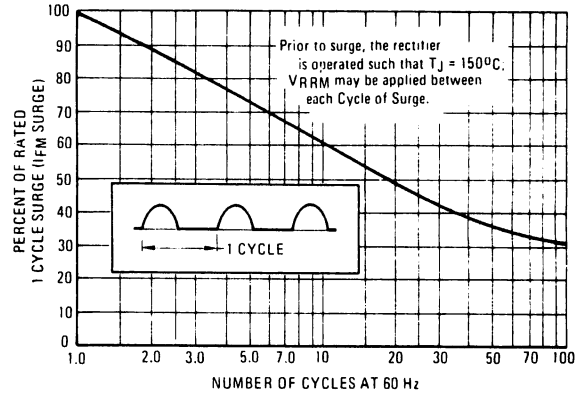

FIGURE 2 – MAXIMUM SURGE CAPABILITY



NOTE 1

DUTY CYCLE, $D = t_p/t_1$
 PEAK POWER, P_{pk} , is peak of an equivalent square power pulse.

To determine maximum junction temperature of the diode in a given situation, the following procedure is recommended:

The temperature of the case should be measured using a thermocouple placed on the case at the temperature reference point (see Note 3). The thermal mass connected to the case is normally large enough so that it will not significantly respond to heat surges generated in the diode as a result of pulsed operation once steady state conditions are achieved. Using the measured value of T_C , the junction temperature may be determined by:

$$T_J = T_C + \Delta T_{JC}$$

where ΔT_{JC} is the increase in junction temperature above the case temperature. It may be determined by:

$$\Delta T_{JC} = P_{pk} \cdot R_{\theta JC} [D + (1 - D) \cdot r(t_1 + t_p) + r(t_p) - r(t_1)]$$

where

- $r(t)$ = normalized value of transient thermal resistance at time, t , from Figure 3, i.e.:
- $r(t_1 + t_p)$ = normalized value of transient thermal resistance at time $t_1 + t_p$

FIGURE 3 – THERMAL RESPONSE

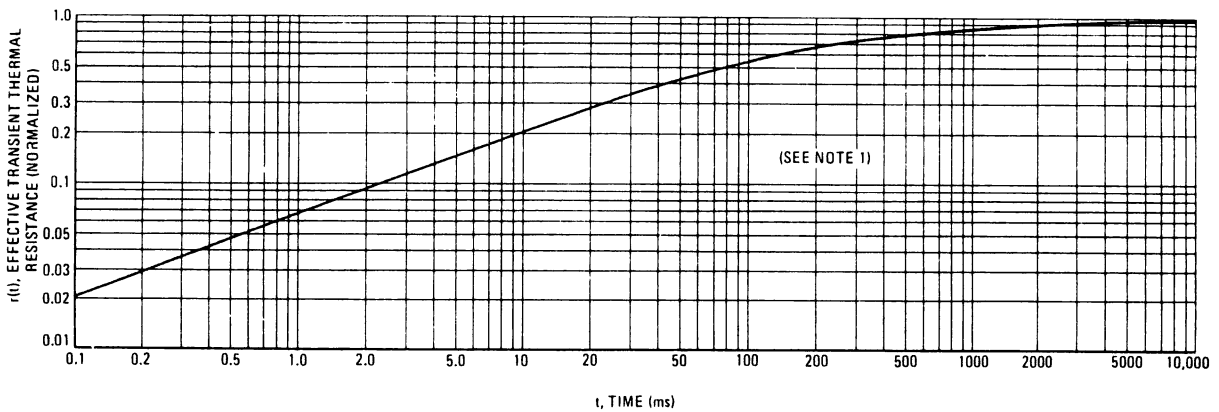

1N3909 thru 1N3913, MR1396

SINE WAVE INPUT

FIGURE 4 – FORWARD POWER DISSIPATION

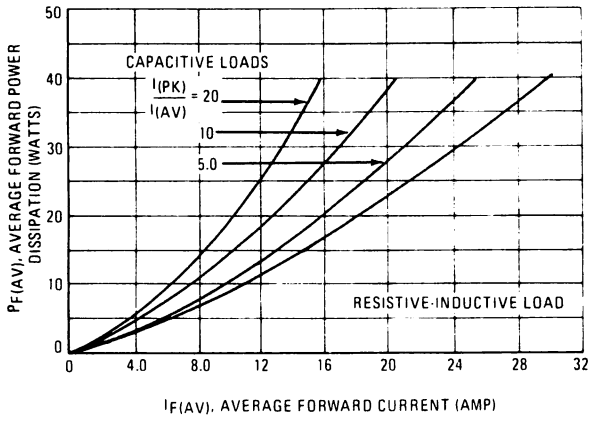

SQUARE WAVE INPUT

FIGURE 5 – FORWARD POWER DISSIPATION

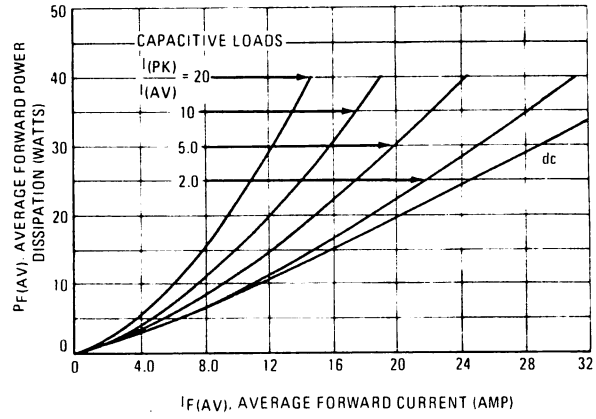

FIGURE 6 – CURRENT DERATING

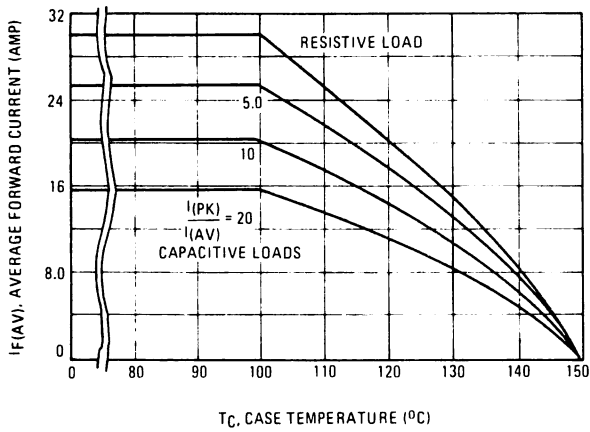

FIGURE 7 – CURRENT DERATING

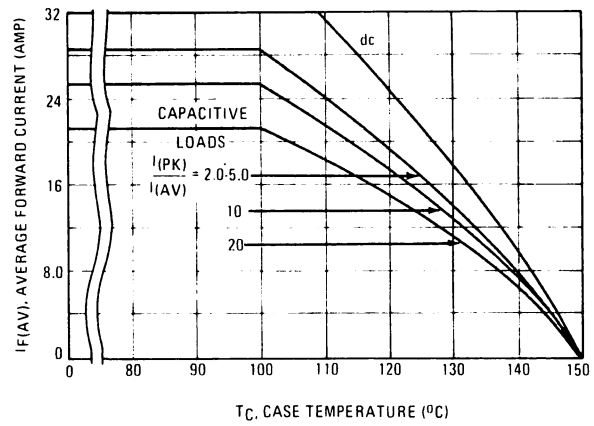

FIGURE 8 – TYPICAL REVERSE CURRENT

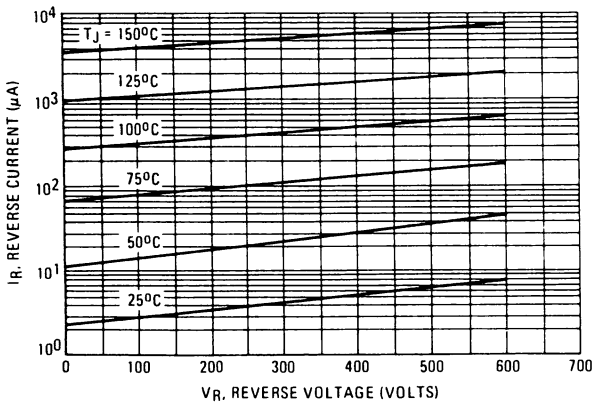
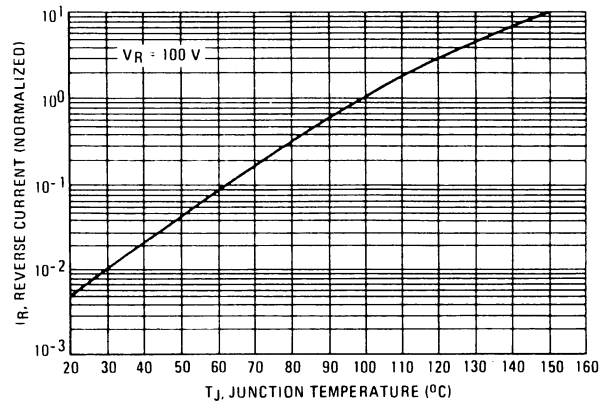

FIGURE 9 – NORMALIZED REVERSE CURRENT



1N3909 thru 1N3913, MR1396

TYPICAL DYNAMIC CHARACTERISTICS

FIGURE 10 – FORWARD RECOVERY TIME

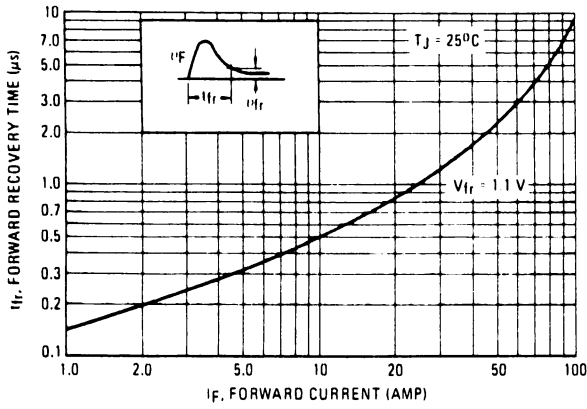
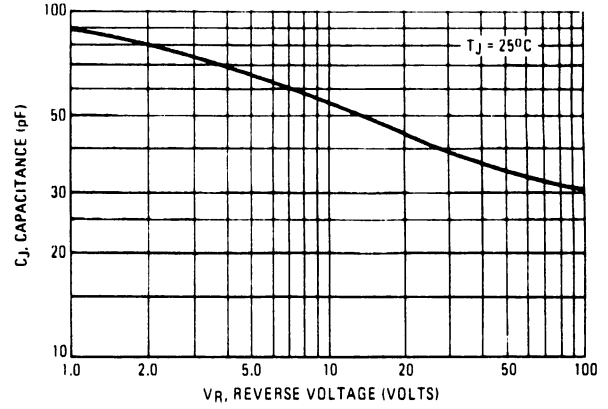

FIGURE 11 – JUNCTION CAPACITANCE



TYPICAL RECOVERED STORED CHARGE DATA

FIGURE 12 – $T_J = 25^\circ C$

(See Note 2)

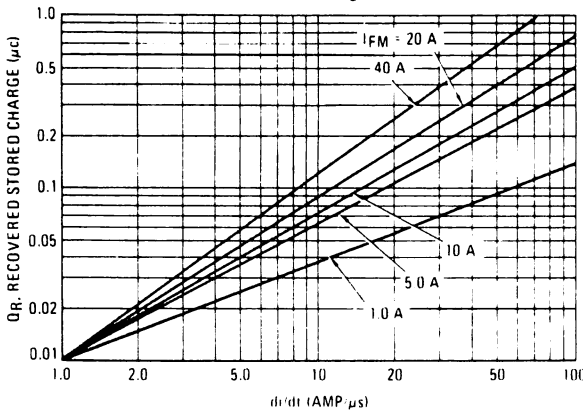

FIGURE 13 – $T_J = 75^\circ C$

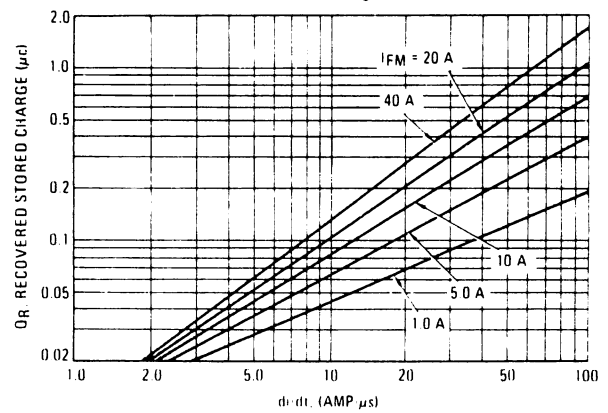

FIGURE 14 – $T_J = 100^\circ C$

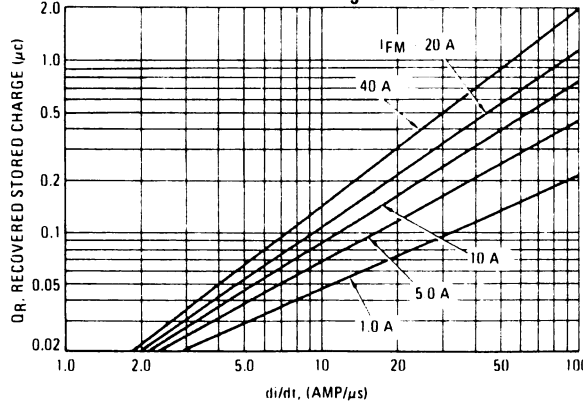
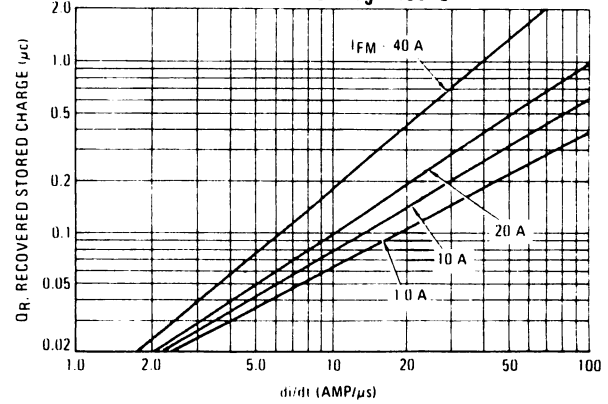

FIGURE 15 – $T_J = 150^\circ C$



1N3909 thru 1N3913, MR1396

FIGURE 16 – REVERSE RECOVERY CIRCUIT

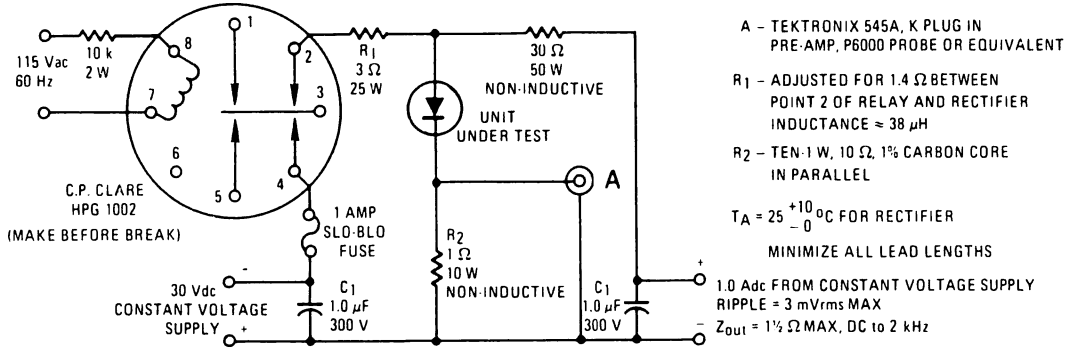
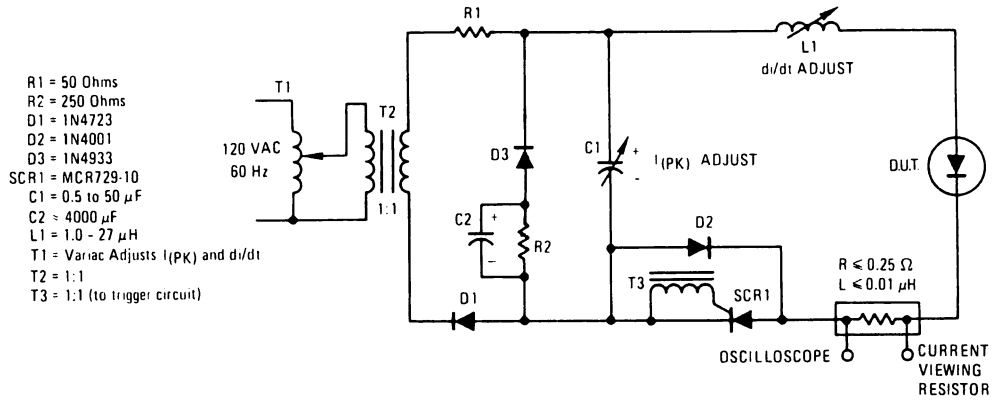

FIGURE 17 – JEDEC REVERSE RECOVERY CIRCUIT



NOTE 2

Reverse recovery time is the period which elapses from the time that the current, thru a previously forward biased rectifier diode, passes thru zero going negatively until the reverse current recovers to a point which is less than 10% peak reverse current.

Reverse recovery time is a direct function of the forward current prior to the application of reverse voltage.

For any given rectifier, recovery time is very circuit dependent. Typical and maximum recovery time of all Motorola fast recovery power rectifiers are rated under a fixed set of conditions using $I_F = 1.0$ A, $V_R = 30$ V. In order to cover all circuit conditions, curves are given for typical recovered stored charge versus commutation di/dt for various levels of forward current and for junction temperatures of 25°C, 75°C, 100°C, and 150°C.

To use these curves, it is necessary to know the forward current level just before commutation, the circuit commutation di/dt , and the operating junction temperature. The reverse recovery test current waveform for all Motorola fast recovery rectifiers is shown.

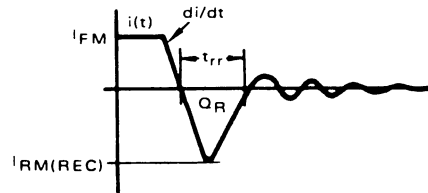

From stored charge curves versus di/dt , recovery time (t_{rr}) and peak reverse recovery current ($I_{RM(REC)}$) can be closely approximated using the following formulas:

$$t_{rr} = 1.41 \times \left[\frac{Q_R}{di/dt} \right]^{1/2}$$

$$I_{RM(REC)} = 1.41 \times \left[Q_R \times di/dt \right]^{1/2}$$

PACKAGE MECHANICAL DATA

DO 5 Metal

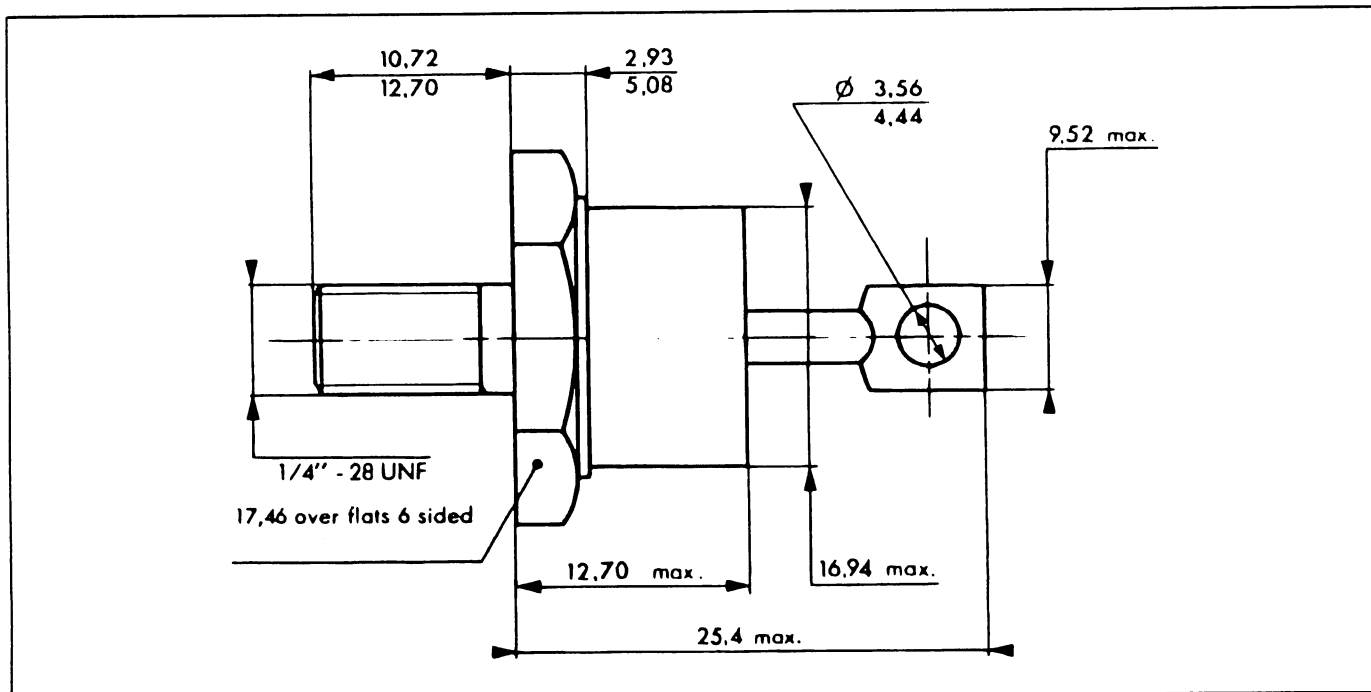

Marking : Cathode connected to case : type number

Anode connected to case : type number + suffix R

Weight : 18.84g

Recommended torque value : 250cm. N

Maximum torque value : 310cm. N