

1 Product Description

The TLE4922 is an active mono cell Hall sensor suited to detect motion and position of ferromagnetic and permanent magnet structures. An additional self-calibration module has been implemented to achieve optimum accuracy during normal running operation.

1.1 Target Application

The TLE4922 is a speed sensor especially optimized for small engine (2- and 3-wheeler) applications.

- **Crankshaft** speed and position sensing
- **Transmission** speed on output shaft
- **Speedometer** application

Excellent sensitivity and accuracy combined with its wide operational temperature range makes the sensor ideally suited for harsh environments.

1.2 Key Features and Benefits

- Twist independent mounting (**TIM**) “enables one sensor fits all”
- Small thin package (PG-SSO-4-1)
- Protected against harsh environment due to
 - **Short-circuit current limitation** at the output
 - **Over temperature shutdown** at the output and
 - **Reverse voltage protection**
- Supreme performance due to adaptive symmetrical hysteresis / threshold
- **Independent of back bias magnet polarity** due to $\pm 400\text{mT}$ full scale range
- Enhanced EMC & ESD robustness - ESD : $\pm 3\text{kV HBM}$
- Wide operating temperature range - T_{junction} : $-40^\circ\text{C} - 155^\circ\text{C}$
- True **zero speed** up to 8kHz signal frequency
- Enabling Low Power Application: **I_{dd} = 5mA** at $V_{\text{DD}} = 9\text{V}$
- Large operating voltage range of 4.5V up to 18V
- Robustness against wheel run outs enables to **sense broad range of wheels**

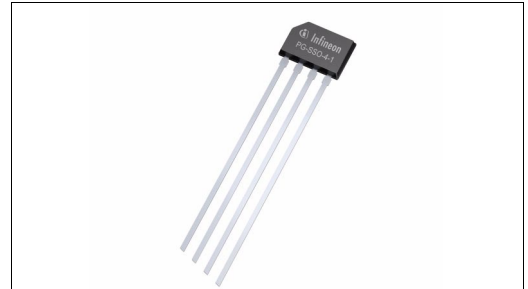

Figure 1-2 Package PG-SSO-4-1

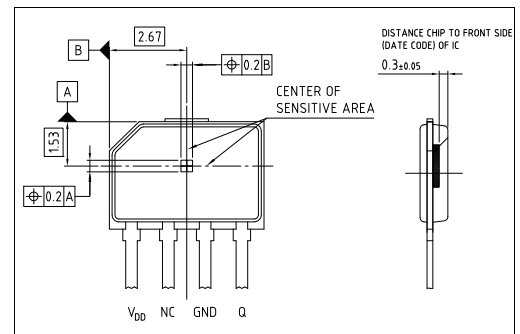

Figure 1-3 Pinning, Sensitive Area

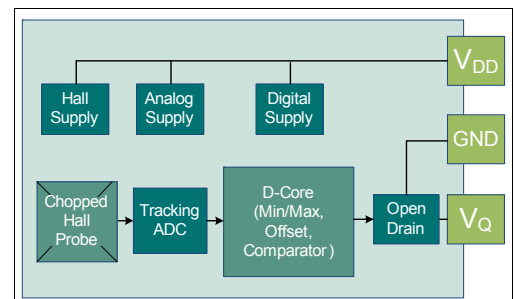

Figure 1-4 Blockdiagram TLE4922

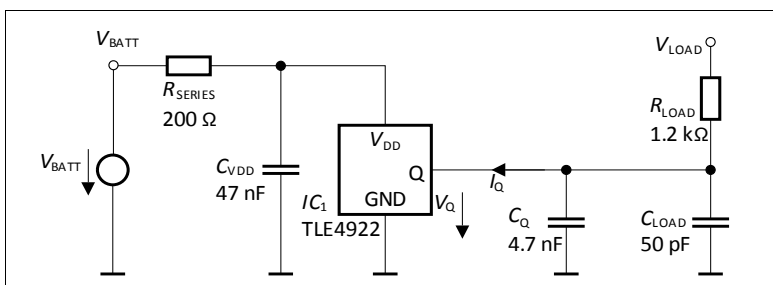

Figure 1-1 Application circuit TLE4922

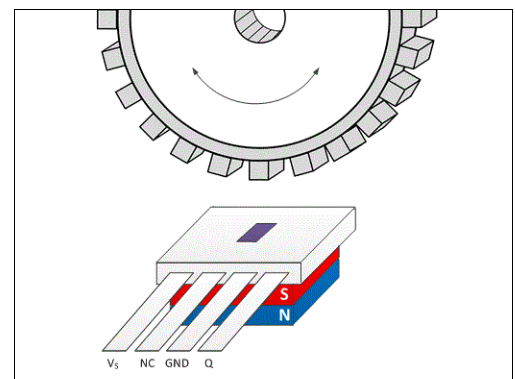

Figure 1-5 Wheel with sensor

Product Type	Marking	Ordering Code	Package
TLE4922-XAN-F	22BAA1	SP001106758	PG-SSO-4-1

2 Specification

The listed characteristics are ensured over the operating range and lifetime of the integrated circuit.

2.1 Absolute Maximum Ratings

Table 2-1 Absolute Maximum Ratings

Parameter	Symbol	Values			Unit	Note or Test Condition
		Min.	Typ.	Max.		
Supply voltage	V_S	-18	-	-	V	
		-	-	18	V	
	V_{SAC}	-	-	30	V	max. 1 min with $R_{SERIES} = 200\Omega$
Output OFF voltage	V_Q	-1	-	-	V	max. 60 min @ $T_A = 25^\circ\text{C}$
		-0.3	-	18	V	
Output ON voltage	V_Q	-	-	18	V	
Junction temperature	$T_J^{1)}$			195	$^\circ\text{C}$	3h
Overall lifetime	$T_{Pol}^{2)}$	-40	-	150	$^\circ\text{C}$	0.2 years
		-40	-	50	$^\circ\text{C}$	15 years
ESD compliance	ESD_{HBM}	-3	-	3	kV	HBM according ANSI/ESDA/JEDEC JS-001

- 1) In temperature range between operating temperature and absolute maximum temperature no functionality is guaranteed.
- 2) Maximum exposure time at other junction temperatures shall be calculated based on the values specified using the Arrhenius-model.

Note: Stresses above the max. values listed here may cause permanent damage to the device. Exposure to absolute maximum rating conditions for extended periods may affect device reliability. Maximum ratings are absolute ratings; exceeding only one of these values may cause irreversible damage to the integrated circuit.

2.2 Operating Range

The following operating conditions must not be exceeded in order to ensure correct operation of the IC. All parameters specified in the following sections refer to these operating conditions unless otherwise mentioned.

Table 2-2 Operating Range

Parameter	Symbol	Values			Unit	Note or Test Condition
		Min.	Typ.	Max.		
Supply voltage	V_S	4.5	-	16	V	
Continuous output ON current	I_Q	-	-	8.8	mA	
Operating junction temperature	$T_J^{1)}$	-40	-	155	$^\circ\text{C}$	2000h
Frequency range of magnetic input signal	f	0 ²⁾	-	8000	Hz	

- 1) Typical R_{thJA} is 170K/W. As soon as back bias magnet is attached or customer mold covers the TLE4922 this value will decrease due to larger surface and mass of the module. Maximum exposure time at other junction temperatures shall be calculated based on the values specified using the Arrhenius-model.
- 2) Maximum one additional pulse may occur due to temperature variation during stand still.

2.3 Electrical Characteristics

Table 2-3 Electrical Parameters

Parameter	Symbol	Values			Unit	Note or Test Condition
		Min.	Typ.	Max.		
Supply current	I_S	3.5	5.3	7.0	mA	
Output saturation voltage	V_{QSAT}	-	0.15	0.4	V	$I_Q = 8.8$ mA
Output leakage current	I_{QLEAK}	-	-	10	μ A	
Current limit for short-circuit protection	$I_{QSHORT}^{1)}$	37	44	52	mA	
Junction temperature for output protection	$T_{PROT}^{1)}$	175	195	215	$^{\circ}$ C	Output will shut down (high impedance) when exceeded
Power on time	$t_{ON}^{1)}$	-	0.7	0.9	ms	
Output fall time	$t_f^{2)}$	2.2	2.8	3.8	μ s	$V_{LOAD} = 5$ V, $C_{LOAD} = 4.7$ nF, $R_{LOAD} = 1.2$ k Ω
Output rise time	$t_r^{1)2)}$	1	-	20	μ s	$V_{LOAD} = 5$ V, $C_{LOAD} = 4.7$ nF, $R_{LOAD} = 1.2$ k Ω
Delay time	$t_d^{1)3)}$	12.5	18	23.5	μ s	$V_{LOAD} = 5$ V, $C_{LOAD} = 4.7$ nF, $R_{LOAD} = 1.2$ k Ω , $f = 5$ kHz, see Figure 2-1

1) Parameter is characterized by simulation/verification

2) Time between 20% and 80% value of V_{LOAD}

3) Only valid for the falling edge

2.4 Magnetic Characteristics and Self-Calibration Characteristics

Table 2-4 Magnetic Characteristics and Self-Calibration Characteristics: 10 Gauss = 1mT

Parameter	Symbol	Values			Unit	Note / Test Condition
		Min.	Typ.	Max.		
Linear Region	$B_{LR}^{1)}$	-400	-	400	mT	
Peak to peak magnetic hysteresis	$B_{MIN}^{1)}$	2.0	3.0	5.3	mT	Full frequency range
		2.0	3.0	3.8	mT	Up to 3kHz signal frequency
Temperature compensation of magnetic hysteresis	TC_{Bmin}	-	-650	-	ppm	Temperature range from 25 $^{\circ}$ C to 150 $^{\circ}$ C
Back Bias Magnet Range	B_{BIAS}	-400	-	400	mT	At $T_a = 25^{\circ}$ C, please notice relation between back bias magnet and linear region as described in user manual
Duty Cycle	$DC^{2)}$	40	50	60	%	
		30	50	70	%	Including EMC (magnetic distortion)
Number of falling output edges required to be calibrated	$n_{Calib}^{2)3)}$	-	-	3	-	At 4 th falling edge full accuracy reached.
Relative phase error in calibrated mode	$\varphi_{rel}^{2)4)}$	-	± 0.3	± 1.5	$^{\circ}$ crank	Forward and backward rotational direction. Temperature and airgap included.
Output falling edge repeatability (phase jitter) in calibrated mode	$\varphi_{jitter}^{2)4)}$	-	0.05	0.2	$^{\circ}$ crank	99.7 %, 3 pulses out of 1000 above limit. Equivalent to $\pm 3\sigma$ of a Gaussian distribution.

1) is calculated out of measured sensitivity

2) Parameter is characterized by simulation/verification

3) Maximum one additional pulse may occur due to temperature variation during stand still

4) Performance measured on wheel described in [Chapter 2.6](#) within air gap range 0.5mm to 3.2mm

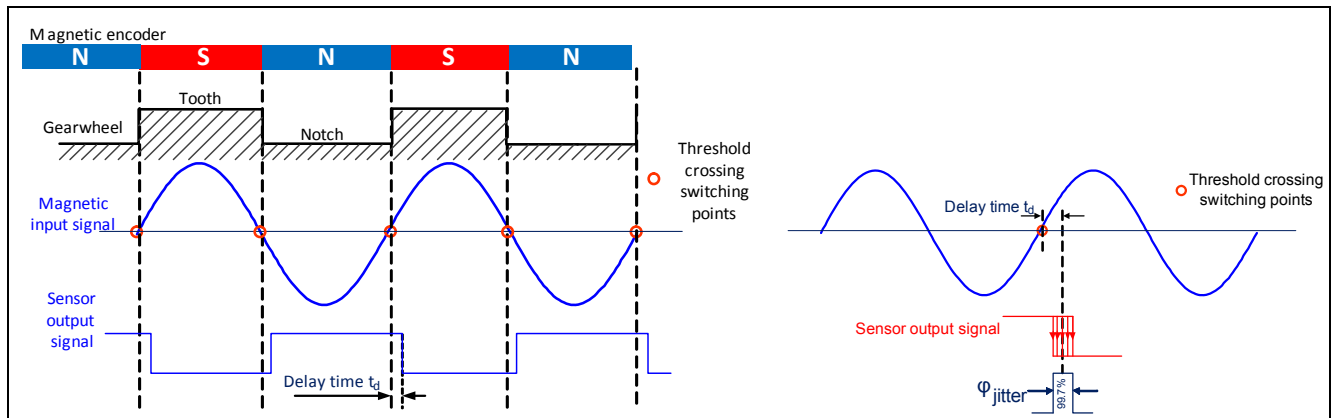

Figure 2-1 Phase error and delay time definition

Phase jitter definition

2.5 Electromagnetic Compatibility (EMC)

The TLE4922 is characterized according to the IC level EMC requirements described in the “Generic IC EMC Test Specification” Version 1.2 from 2007¹⁾. Additionally, component level EMC characterizations according to ISO 7637-2:2011, ISO 7637-3:2007 and ISO 16750-2:2010 regarding pulse immunity and CISPR 25 (2009-01) Ed. 3.0 regarding conducted emissions are performed.

Figure 1-1 on first page outlines all needed external components to operate the DUT under application conditions. They are treated as inherent part of the DUT during component level EMC characterizations.

Note: Characterisation of Electro Magnetic Compatibility (EMC) are carried out on sample base of one qualification lot. Not all specification parameters are monitored during EMC exposure. Only key parameters e.g. switching current and duty cycle are monitored.

Parameter	Symbol	Level	Class
Testpulse 1	V_{EMC}	-100 V	C
Testpulse 2a ¹⁾		100 V	A
Testpulse 2b		10 V	C
Testpulse 3a		-150 V	A
Testpulse 3b		100 V	A
Testpulse 4 ²⁾		-7 V	C
Testpulse 5b ³⁾		86.5 V	A

- 1) ISO 7637-2 (2004) describes internal resistance = 2Ω.
- 2) According to 7637-2 for test pulse 4 the test voltage shall be 12 V +/- 0.2 V.
- 3) A central load dump protection of 35V is used.

1) The document is available online at <http://www.zvei.org/Verband/Publikationen/Seiten/Generic-IC-EMCTest-Specification-english.aspx>

2.6 Reference Target Wheel

Table 2-5 Toothed wheel performance

Parameter	Symbol	Values			Unit	Note or Test Condition
		Min.	Typ.	Max.		
Operational IC air-gap	$AG^{1)2)}$	-	-	3.2	mm	Field strength of 300mT at 0.7mm above surface of back-bias magnet (is sensitive area of TLE4922)
Air-gap variation over one complete target revolution. Global run-out.	$AG_{GLRO}^{1)}$	-	-	0.5	mm	Difference between min. and max. air-gap over one complete target revolution.

1) Parameter is characterized by verification

2) Measured from surface of package to toothed wheel, explained in [Figure 2-2](#).

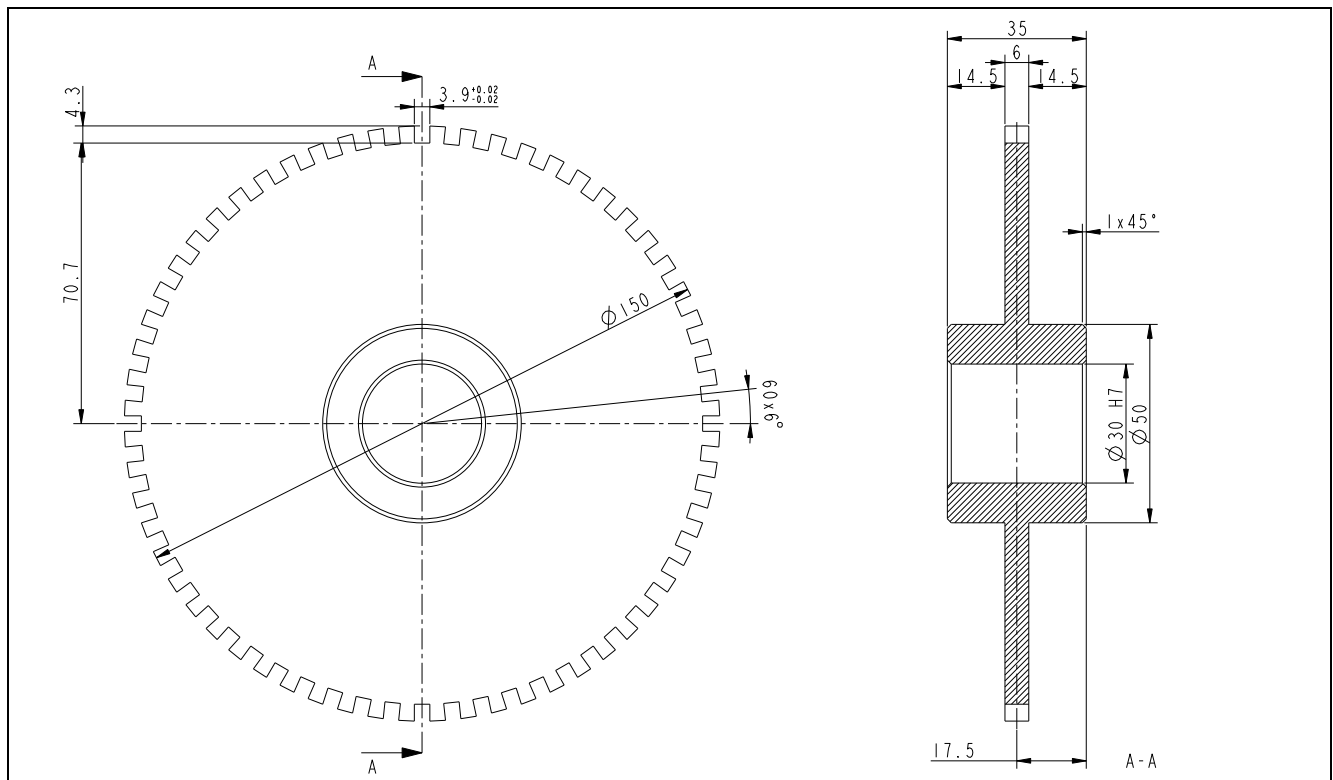

Figure 2-2 Infineon reference toothed wheel: dimension in mm

Table 2-6 Reference target wheel geometry

Parameter	Typ value	Unit	Remarks
Material	ST37	-	
Tooth notch ratio	1.00		

2.7 Performance Graphs

Following graphs of typical sensor behavior will help to optimize application performance:

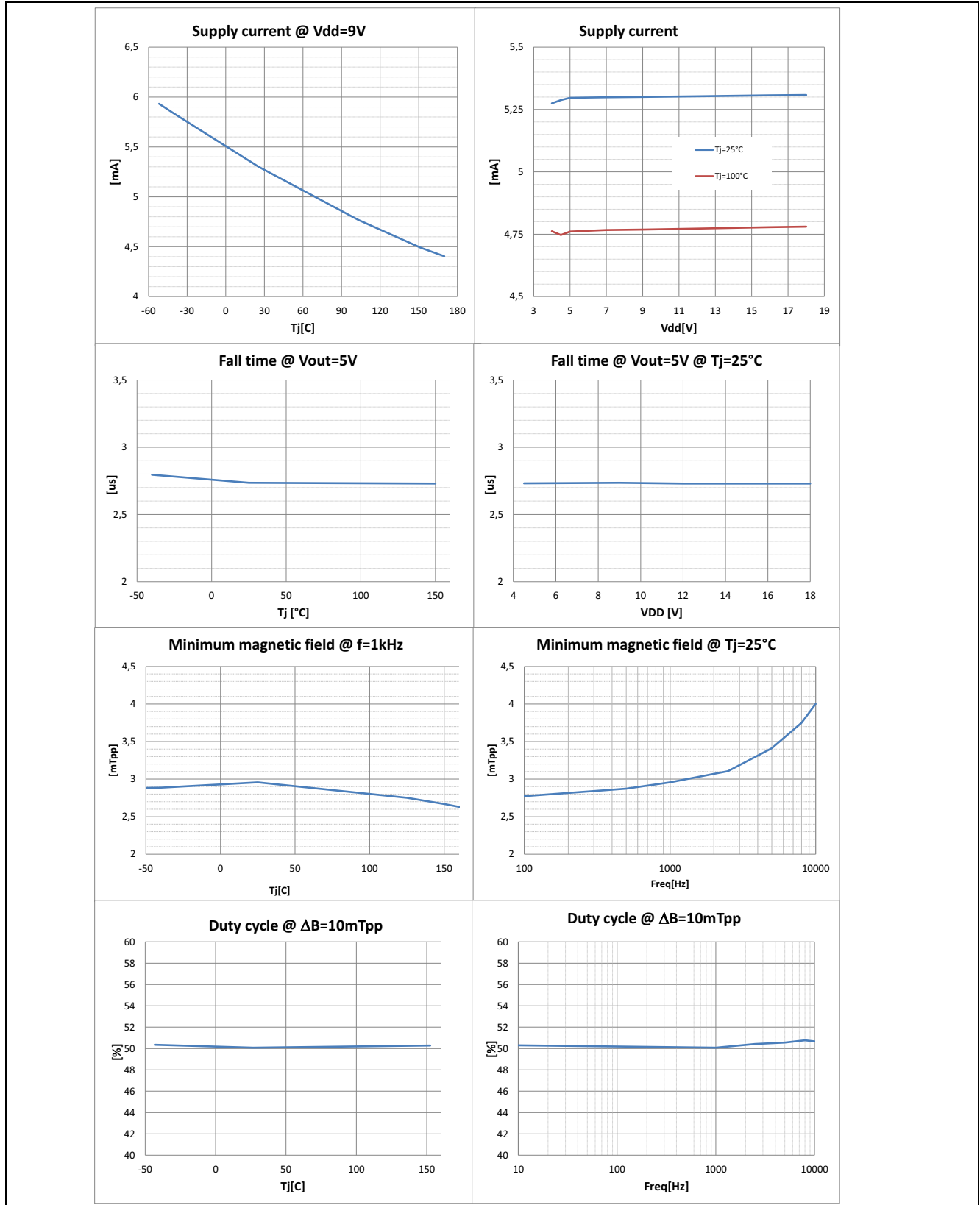

Figure 2-3 Typical Performance

2.8 Application

Basic functionality

The TLE4922 is a mono-cell Hall sensor with analog to digital converter and full digital signal processing for detecting the magnetic field crossing of the threshold levels. A chopped Hall probe is used to mimic the offset and has advantages for 0-Hz feature. **Figure 2-1** shows the basic functionality of TLE4922.

Unique Feature: Polarity of Pre Induction

The back bias magnet can be mounted in both directions to TLE4922 without any difference in performance. One polarity results in switching the output to “LOW” when passing a tooth and to “HIGH” when passing a notch, whereas the other polarity of back-bias magnet will switch the output to “HIGH” when passing a tooth and to “LOW” when passing a notch.

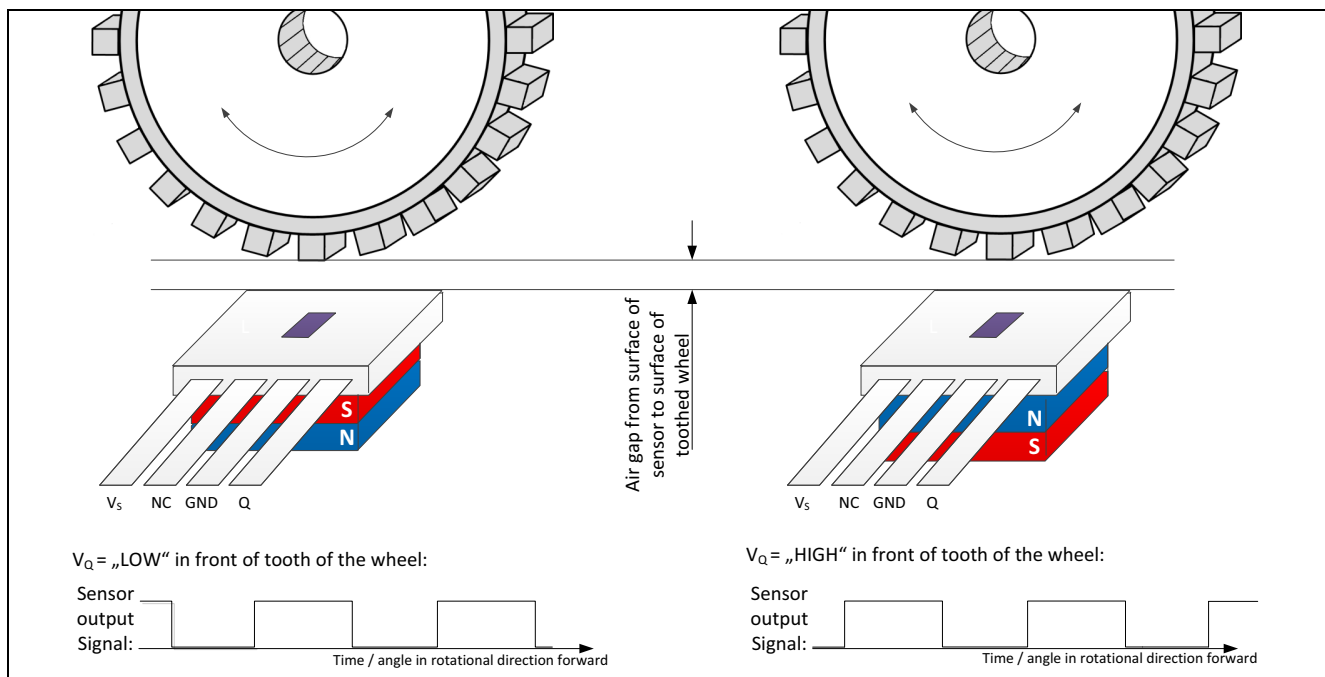

Figure 2-4 Changing polarity of back bias magnet will change the polarity of TLE4922 output

Start-Up and Running Mode

In Start-Up-Mode the TLE4922 starts with output at “HIGH” and stays there until a first minimum in magnetic field is detected after start-up time. Calibrated mode is reached after a maximum of four output transitions (The offset compensation algorithm is considering 4 teeth for averaging). At the 4th falling edge full accuracy on output signal is reached. These first transitions are determined by the detection of magnetic signal maxima and minima. Output transitions in running phase are determined by the hidden adaptive hysteresis algorithm.

Application circuit

Figure 1-1 on page one shows an option of an application circuit. The resistor R_S is recommended due to reason of EMC. The resistor R_L has to be at a value to match the applied V_{ECU} to keep I_Q limited to the operating range of maximal 8.8mA. e.g.: $V_{LOAD} = 9V$; $I_Q = 9V/1200 \Omega = 7.5mA$

Consideration on R_{thJA}

The R_{th} is modified by attaching a back-bias magnet or doing molding at the customer. There is dependency on the attached wires: The thicker the attached wire the smaller the value of R_{th} . It depends on ambient condition: When one end of the module is cooled in oil or through air-flow the R_{thJA} will decrease.

Global run out

Due to averaging, global run out is depending on the number of teeth. The wheel in **Chapter 2.6** allows a global run out of 0.8mm. Wheels with equal or more than 8 teeth are capable of up to 0.5mm global run out.

Revision History

4 Revision History

Revision	Date	Changes
1.0	2016-11-21	Initial release

Trademarks of Infineon Technologies AG

AURIX™, C166™, CanPAK™, CIPOS™, CIPURSE™, CoolMOS™, CoolSET™, CORECONTROL™, CROSSAVE™, DAVE™, DI-POL™, EasyPIM™, EconoBRIDGE™, EconoDUAL™, EconoPIM™, EconoPACK™, EiceDRIVER™, eupec™, FCOS™, HITFET™, HybridPACK™, I²RF™, ISOFACE™, IsoPACK™, LITIX™, MIPAQ™, ModSTACK™, my-d™, NovalithIC™, OptiMOS™, ORIGA™, POWERCODE™, PRIMARION™, PrimePACK™, PrimeSTACK™, PRO-SIL™, PROFET™, RASIC™, ReverSave™, SatRIC™, SIEGET™, SINDRION™, SIPMOS™, SmartLEWIS™, SPOC™, SOLID FLASH™, TEMPFET™, thinQ™, TRENCHSTOP™, TriCore™.

Other Trademarks

Advance Design System™ (ADS) of Agilent Technologies, AMBA™, ARM™, MULTI-ICE™, KEIL™, PRIMECELL™, REALVIEW™, THUMB™, μVision™ of ARM Limited, UK. AUTOSAR™ is licensed by AUTOSAR development partnership. Bluetooth™ of Bluetooth SIG Inc. CAT-iq™ of DECT Forum. COLOSSUS™, FirstGPS™ of Trimble Navigation Ltd. EMV™ of EMVCo, LLC (Visa Holdings Inc.). EPCOS™ of Epcos AG. FLEXGO™ of Microsoft Corporation. FlexRay™ is licensed by FlexRay Consortium. HYPERTERMINAL™ of Hilgraeve Incorporated. IEC™ of Commission Electrotechnique Internationale. IrDA™ of Infrared Data Association Corporation. ISO™ of INTERNATIONAL ORGANIZATION FOR STANDARDIZATION. MATLAB™ of MathWorks, Inc. MAXIM™ of Maxim Integrated Products, Inc. MICROTEC™, NUCLEUS™ of Mentor Graphics Corporation. MIPI™ of MIPI Alliance, Inc. MIPS™ of MIPS Technologies, Inc., USA. muRata™ of MURATA MANUFACTURING CO., MICROWAVE OFFICE™ (MWO) of Applied Wave Research Inc., OmniVision™ of OmniVision Technologies, Inc. Openwave™ Openwave Systems Inc. RED HAT™ Red Hat, Inc. RFMD™ RF Micro Devices, Inc. SIRIUS™ of Sirius Satellite Radio Inc. SOLARIS™ of Sun Microsystems, Inc. SPANSION™ of Spansion LLC Ltd. Symbian™ of Symbian Software Limited. TAIYO YUDEN™ of Taiyo Yuden Co. TEAKLITE™ of CEVA, Inc. TEKTRONIX™ of Tektronix Inc. TOKO™ of TOKO KABUSHIKI KAISHA TA. UNIX™ of X/Open Company Limited. VERILOG™, PALLADIUM™ of Cadence Design Systems, Inc. VLYNQ™ of Texas Instruments Incorporated. VXWORKS™, WIND RIVER™ of WIND RIVER SYSTEMS, INC. ZETEX™ of Diodes Zetex Limited.

Last Trademarks Update 2011-11-11

www.infineon.com

Edition 2016-11-21

Published by

Infineon Technologies AG

81726 Munich, Germany

© 2014 Infineon Technologies AG.

All Rights Reserved.

Do you have a question about any aspect of this document?

Email: erratum@infineon.com

Document reference

Legal Disclaimer

The information given in this document shall in no event be regarded as a guarantee of conditions or characteristics. With respect to any examples or hints given herein, any typical values stated herein and/or any information regarding the application of the device, Infineon Technologies hereby disclaims any and all warranties and liabilities of any kind, including without limitation, warranties of non-infringement of intellectual property rights of any third party.

Information

For further information on technology, delivery terms and conditions and prices, please contact the nearest Infineon Technologies Office (www.infineon.com).

Warnings

Due to technical requirements, components may contain dangerous substances. For information on the types in question, please contact the nearest Infineon Technologies Office. Infineon Technologies components may be used in life-support devices or systems only with the express written approval of Infineon Technologies, if a failure of such components can reasonably be expected to cause the failure of that life-support device or system or to affect the safety or effectiveness of that device or system. Life support devices or systems are intended to be implanted in the human body or to support and/or maintain and sustain and/or protect human life. If they fail, it is reasonable to assume that the health of the user or other persons may be endangered.