

Low Rho SMD Series



Agency Approvals

AGENCY	AGENCY FILE NUMBER
	78165 *
	E74889 *
	72161796 *

* - See *Electrical Characteristic Table* for approved part numbers.

Description

PolySwitch® low resistivity SMD (surface-mount device) is a versatile device well suited for general applications which have space-constrained, low power dissipation and high environmental reliability requirements.

The devices can help provide both overcurrent and overtemperature protection for battery pack PCMs (protection circuit modules), circuit PCBA and signal/power I/O interface. The resettable feature ensures the device will “Trip” and protect the application during the faults and yet regain the functions once the error is removed.

Features

- Current ratings from 1.75 to 6.0A
- Maximum electrical rating: 6VDC and short circuit current 50A
- Halogen free (Br≤900ppm, Cl≤900ppm, and Br+Cl≤1500ppm)
- Ultra low internal resistance
- Automatic Reset
- RoHS Complaint, lead-free and halogen free

Applications

- Mobile and smart phones
- Wearable devices
- Portable game console
- VR/AR head mount display (HMD)
- Tablets and eBook
- Portable printer and projector
- Li-Ion battery Powered Mobile Devices
- USB Connection Ports

Electrical Characteristics

Part Number	I _H (A)	I _T (A)	V _{MAX} (VDC)	I _{MAX} (A)	P _{D MAX} (W)	Max Time-to-Trip		R _{MIN} (\wedge)	R _{1MAX} (v)	Agency Recognition
						(A)	(S)			
nanoSMDLR Series Size 3216mm/1206mils										
nanoSMD175LR	1.75	5.00	6	50	1.00	9.50	1.00	0.008	0.034	UL, CSA, TÜV
nanoSMD200LR	2.00	6.00	6	50	1.00	9.50	3.00	0.006	0.024	UL, CSA
nanoSMD270LR	2.70	6.30	6	50	1.00	8.00	5.00	0.005	0.018	UL, CSA, TÜV
nanoSMD350LR	3.50	6.30	6	50	1.00	8.00	5.00	0.004	0.018	UL, CSA, TÜV
nanoSMD380LR	3.80	8.00	6	50	1.00	9.50	10.00	0.004	0.014	UL
nanoSMD400LR	4.00	8.00	6	50	1.00	20.00	2.00	0.004	0.010	
nanoSMD450LR	4.50	9.00	6	50	1.00	25.00	2.00	0.002	0.008	
nanoSMD500LR	5.00	10.00	6	50	1.00	25.00	2.00	0.002	0.008	UL, CSA, TÜV
nanoSMD550LR	5.50	11.00	6	50	1.00	25.00	2.00	0.002	0.007	LR2
nanoSMD600LR	6.00	12.00	6	50	1.00	25.00	2.00	0.002	0.007	LR2
microSMDLR Series Size 3225mm/1210mils										
microSMD190LR	1.90	4.90	6	50	1.00	9.50	4.00	0.006	0.021	UL, CSA
microSMD200LR	2.00	5.00	6	50	1.00	9.50	4.00	0.006	0.021	UL, CSA
microSMD250LR-A	2.50	5.20	6	50	1.00	9.50	5.00	0.005	0.018	UL, CSA
microSMD350LR-D	3.50	9.00	6	50	1.00	9.50	10.00	0.0025	0.011	UL, CSA
microSMD380LR	3.80	9.00	6	50	1.00	9.50	10.00	0.0025	0.009	UL, CSA
microSMD400LR	4.00	9.00	6	50	1.00	9.50	10.00	0.0025	0.0099	
microSMD450LR	4.50	9.00	5	50	1.00	25.00	2.00	0.002	0.008	UL
microSMD500LR	5.00	10.00	6	50	1.00	25.00	2.00	0.002	0.007	
microSMD550LR	5.50	11.00	5	50	1.00	25.00	2.00	0.002	0.0065	
microSMD600LR	6.00	12.00	6	50	1.00	25.00	2.00	0.002	0.0063	UL

Temperature Derating

Part Number	Ambient Operating Temperature										
	-40°C	-20°C	0°C	20°C	25°C	40°C	50°C	60°C	70°C	80°C	85°C
nanoSMDLR Series Size 3216mm/1206mils											
nanoSMD175LR	3.00	2.60	2.20	1.75	1.70	1.40	1.20	1.00	0.80	0.60	0.50
nanoSMD200LR	3.60	3.20	2.80	2.00	1.90	1.80	1.60	1.40	1.20	1.00	0.80
nanoSMD270LR	4.00	3.50	3.00	2.70	2.60	2.20	2.00	1.60	1.40	1.20	1.10
nanoSMD350LR	5.50	4.80	4.00	3.50	3.30	2.70	2.30	1.90	1.60	1.40	1.30
nanoSMD380LR	5.75	5.15	5.00	3.80	3.74	3.06	2.60	2.20	1.90	1.60	1.50
nanoSMD400LR	5.80	5.20	4.60	4.00	3.90	3.40	3.10	2.82	2.52	2.23	2.10
nanoSMD450LR	6.69	6.00	5.40	4.50	4.40	3.80	3.50	3.30	2.75	2.35	2.16
nanoSMD500LR	7.40	6.60	6.00	5.00	4.90	4.60	4.20	3.70	3.30	3.00	2.80
nanoSMD550LR	7.96	7.19	6.50	5.50	5.30	4.80	4.30	3.80	3.40	3.10	2.90
nanoSMD600LR	8.50	7.80	7.00	6.00	5.72	4.94	4.42	3.90	3.50	3.20	3.00
microSMDLR Series Size 3225mm/1210mils											
microSMD190LR	3.40	2.90	2.40	1.90	1.80	1.40	1.15	0.90	0.65	0.40	0.28
microSMD200LR	3.50	3.00	2.50	2.00	1.90	1.50	1.25	1.00	0.75	0.50	0.38
microSMD250LR-A	4.40	3.80	3.20	2.50	2.40	1.90	1.50	1.25	1.00	0.65	0.50
microSMD350LR-D	5.40	4.75	4.00	3.50	3.20	2.70	2.40	2.00	1.70	1.35	1.20
microSMD380LR	5.71	5.04	4.00	3.80	3.52	3.01	2.67	2.50	2.00	1.66	1.49
microSMD400LR	5.91	5.24	4.70	4.00	3.72	3.21	2.87	2.50	2.20	1.86	1.69
microSMD450LR	7.00	6.20	5.50	4.50	4.40	3.80	3.50	3.20	2.75	2.35	2.16
microSMD500LR	7.40	6.60	6.00	5.00	4.90	4.60	4.20	3.70	3.30	3.00	2.80
microSMD550LR	7.96	7.19	7.00	5.50	5.46	4.88	4.49	4.10	3.50	3.20	3.00
microSMD600LR	8.50	7.80	7.00	6.00	5.70	5.00	4.50	3.90	3.50	3.10	2.90

Note: The temperature derating data is for reference only. Please contact Littelfuse technical support for detail temperature derating information

Temperature Derating Curve

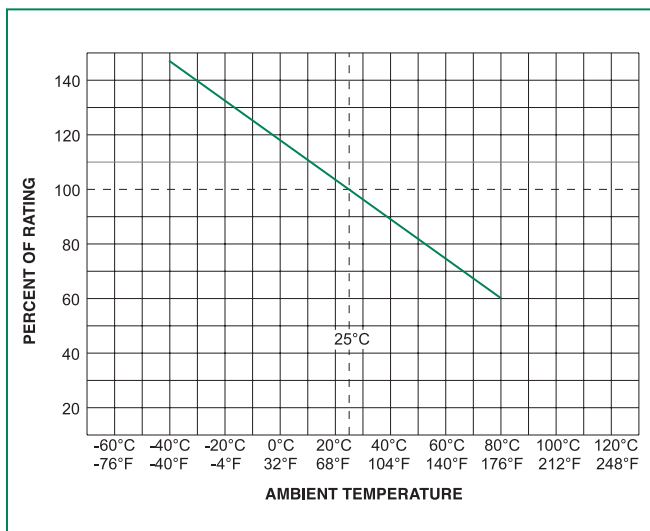

Environmental Specifications

Operating Temperature	-40°C to +80°C
Maximum Device Surface Temperature in Tripped State	125°C
Passive Aging	+85°C, 1000 hours -/+ 10% typical resistance change
Humidity Aging	+85°C, 85% R.H., 100 hours -/+ 15% typical resistance change
Thermal Shock	MIL-STD-202, Method 215 No change
Vibration	MIL-STD-883, Method 2007, Condition A No change
Moisture Sensitivity Level	Level 2a, J-STD-020

Physical Specifications

Terminal Pad Materials	Gold with Nickel Underplate
Soldering Characteristics	ANSI/J-STD-002 Category 3
Solder Heat Withstand	per IEC-STD 68-2-20, Test Tb, Section 5, Method 1A
Flammability Resistance	per IEC 695-2-2 Needle Flame Test for 20 sec.
Recommended Storage Conditions	40°C max, 70% R.H. max; Devices May Not Meet Specified Ratings if Storage Conditions Are Exceeded.

Soldering Parameters

Profile Feature	Pb-Free assembly	
Pre Heat	- Temperature Min ($T_{s(min)}$)	150°C
	- Temperature Max ($T_{s(max)}$)	200°C
	- Time (min to max) (t_s)	60 – 120 seconds
Average ramp up rate (Liquidus Temp (T_L) to peak)	3°C/second max	
$T_{s(max)}$ to T_L - Ramp-up Rate	3°C/second max	
Reflow	- Temperature (T_L) (Liquidus)	217°C
	- Temperature (t_L)	60 – 150 seconds
Peak Temperature (T_p)	260°C	
Time within 5°C of actual peak Temperature (t_p)	30 seconds max	
Ramp-down Rate	2°C/second max	
Time 25°C to peak Temperature (T_p)	8 minutes max	

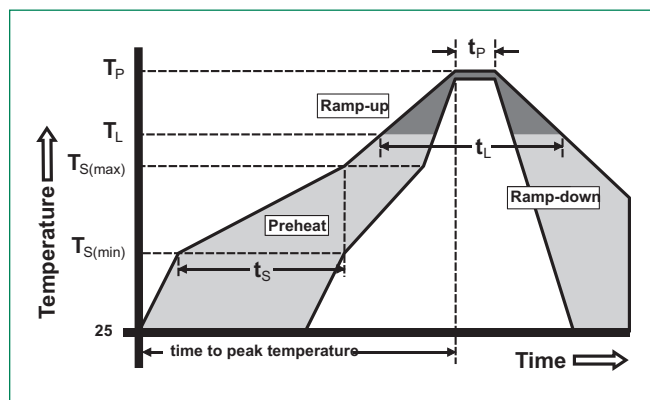

Notes:

- All temperature refer to topside of the package, measured on the package body surface.
- If reflow temperature exceeds the recommended profile, devices may not meet the performance requirements.
- Recommended reflow methods: IR, vapor phase oven, hot air oven, N₂ environment for lead.
- Recommended maximum paste thickness is 0.25 mm (0.010 inch).
- Devices can be cleaned using standard industry methods and solvents.
- Devices can be reworked using the standard industry practices.

Dimensions

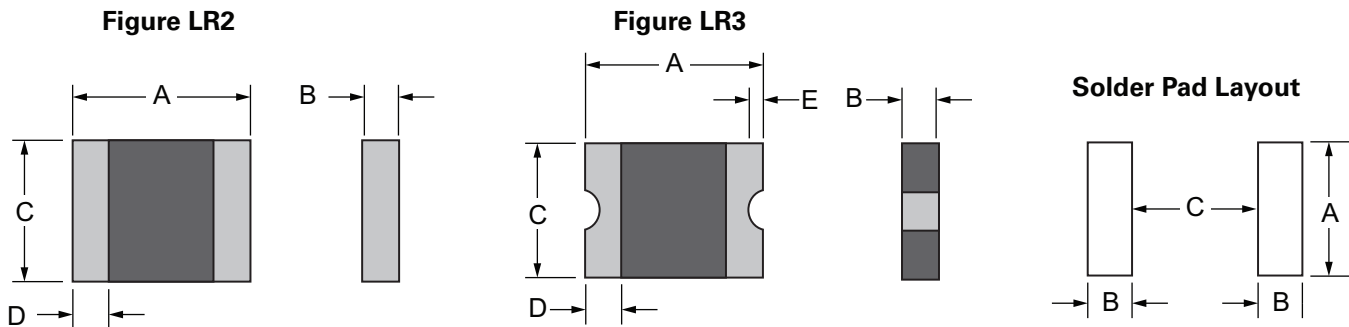

Part Number	A		B		C		D		E	Figure
	Min	Max	Min	Max	Min	Max	Min	Max	Min	
nanoSMDLR Series Size 3216mm/1206mils - Dimension in mm(in)										
nanoSMD175LR	3.00 (0.118)	3.43 (0.135)	0.50 (0.019)	1.00 (0.039)	1.37 (0.054)	1.85 (0.073)	0.25 (0.010)	0.75 (0.030)	—	LR2
nanoSMD200LR	3.00 (0.118)	3.43 (0.135)	0.50 (0.019)	1.00 (0.039)	1.37 (0.054)	1.85 (0.073)	0.25 (0.010)	0.75 (0.030)	—	LR2
nanoSMD270LR	3.00 (0.118)	3.43 (0.135)	0.50 (0.019)	1.00 (0.039)	1.37 (0.054)	1.85 (0.073)	0.25 (0.010)	0.75 (0.030)	—	LR2
nanoSMD350LR	3.00 (0.118)	3.43 (0.135)	0.50 (0.019)	1.00 (0.039)	1.37 (0.054)	1.85 (0.073)	0.25 (0.010)	0.75 (0.030)	—	LR2
nanoSMD380LR	3.00 (0.118)	3.43 (0.135)	0.50 (0.019)	1.00 (0.039)	1.37 (0.054)	1.85 (0.073)	0.25 (0.010)	0.75 (0.030)	—	LR2
nanoSMD400LR	3.00 (0.118)	3.43 (0.135)	0.50 (0.019)	1.00 (0.039)	1.37 (0.054)	1.85 (0.073)	0.25 (0.010)	0.75 (0.030)	—	LR2
nanoSMD450LR	3.00 (0.118)	3.43 (0.135)	0.50 (0.019)	0.80 (0.031)	1.37 (0.054)	1.85 (0.073)	0.25 (0.010)	0.75 (0.030)	—	LR2
nanoSMD500LR	3.00 (0.118)	3.43 (0.135)	0.50 (0.019)	0.80 (0.031)	1.37 (0.054)	1.85 (0.073)	0.25 (0.010)	0.75 (0.030)	—	LR2
nanoSMD550LR	3.00 (0.118)	3.43 (0.135)	0.50 (0.019)	0.80 (0.031)	1.37 (0.054)	1.85 (0.073)	0.25 (0.010)	0.75 (0.030)	—	LR2
nanoSMD600LR	3.00 (0.118)	3.43 (0.135)	0.50 (0.019)	1.00 (0.039)	1.37 (0.054)	1.85 (0.073)	0.25 (0.010)	0.75 (0.030)	—	LR2
microSMDLR Series Size 3225mm/1210mils - Dimension in mm(in)										
microSMD190LR	3.00 (0.118)	3.43 (0.135)	0.50 (0.019)	1.00 (0.039)	2.35 (0.092)	2.80 (0.110)	0.25 (0.010)	0.75 (0.030)	0.076 (0.003)	LR3
microSMD200LR	3.00 (0.118)	3.43 (0.135)	0.50 (0.019)	1.00 (0.039)	2.35 (0.092)	2.80 (0.110)	0.25 (0.010)	0.75 (0.030)	0.076 (0.003)	LR3
microSMD250LR-A	3.00 (0.118)	3.43 (0.135)	0.50 (0.019)	1.00 (0.039)	2.35 (0.092)	2.80 (0.110)	0.25 (0.010)	0.75 (0.030)	0.076 (0.003)	LR3
microSMD350LR-D	3.00 (0.118)	3.43 (0.135)	0.50 (0.019)	1.00 (0.039)	2.35 (0.092)	2.80 (0.110)	0.25 (0.010)	0.75 (0.030)	—	LR2
microSMD380LR	3.00 (0.118)	3.43 (0.135)	0.50 (0.019)	1.00 (0.039)	2.35 (0.092)	2.80 (0.110)	0.25 (0.010)	0.75 (0.030)	—	LR2
microSMD400LR	3.00 (0.118)	3.43 (0.135)	0.50 (0.019)	1.00 (0.039)	2.35 (0.092)	2.80 (0.110)	0.25 (0.010)	0.75 (0.030)	—	LR2
microSMD450LR	3.00 (0.118)	3.43 (0.135)	0.50 (0.019)	1.00 (0.039)	2.35 (0.092)	2.80 (0.110)	0.25 (0.010)	0.75 (0.030)	0.076 (0.003)	LR3
microSMD500LR	3.00 (0.118)	3.43 (0.135)	0.50 (0.019)	1.00 (0.039)	2.35 (0.092)	2.80 (0.110)	0.25 (0.010)	0.75 (0.030)	0.076 (0.003)	LR3
microSMD550LR	3.00 (0.118)	3.43 (0.135)	0.50 (0.019)	1.00 (0.039)	2.35 (0.092)	2.80 (0.110)	0.25 (0.010)	0.75 (0.030)	0.076 (0.003)	LR3
microSMD600LR	3.00 (0.118)	3.43 (0.135)	0.50 (0.019)	1.00 (0.039)	2.35 (0.092)	2.80 (0.110)	0.25 (0.010)	0.75 (0.030)	0.076 (0.003)	LR3

Packaging and Marking Information

Part Number	Tape & Reel Quantity	Standard Package	Part Marking	Recommended Pad Layout Figures [mm (in)]		
				Dimension A (Nom)	Dimension B (Nom)	Dimension C (Nom)
nanoSMDLR Series Size 3216mm/1206mils						
nanoSMD175LR	3,000	15,000	J	1.75 (0.069)	1.10 (0.043)	2.00 (0.079)
nanoSMD200LR	3,000	15,000	T	1.75 (0.069)	1.10 (0.043)	2.00 (0.079)
nanoSMD270LR	3,000	15,000	L	1.75 (0.069)	1.10 (0.043)	2.00 (0.079)
nanoSMD350LR	3,000	15,000	P	1.75 (0.069)	1.10 (0.043)	2.00 (0.079)
nanoSMD380LR	3,000	15,000	P	1.75 (0.069)	1.10 (0.043)	2.00 (0.079)
nanoSMD400LR	3,000	15,000	S	1.75 (0.069)	1.10 (0.043)	2.00 (0.079)
nanoSMD450LR	3,000	15,000	K	1.75 (0.069)	1.10 (0.043)	2.00 (0.079)
nanoSMD500LR	3,000	15,000	H	1.75 (0.069)	1.10 (0.043)	2.00 (0.079)
nanoSMD550LR	3,000	15,000	H	1.75 (0.069)	1.10 (0.043)	2.00 (0.079)
nanoSMD600LR	3,000	15,000	V	1.75 (0.069)	1.10 (0.043)	2.00 (0.079)
microSMDLR Series Size 3225mm/1210mils						
microSMD190LR	3,000	15,000	NONE	2.65 (0.104)	1.00 (0.039)	2.00 (0.079)
microSMD200LR	3,000	15,000	T	2.65 (0.104)	1.00 (0.039)	2.00 (0.079)
microSMD250LR-A	3,000	15,000	L	2.65 (0.104)	1.00 (0.039)	2.00 (0.079)
microSMD350LR-D	3,000	15,000	P	2.65 (0.104)	1.10 (0.043)	2.00 (0.079)
microSMD380LR	3,000	15,000	P	2.65 (0.104)	1.10 (0.043)	2.00 (0.079)
microSMD400LR	3,000	15,000	P	2.65 (0.104)	1.10 (0.043)	2.00 (0.079)
microSMD450LR	3,000	15,000	⊥	2.65 (0.104)	1.00 (0.039)	2.00 (0.079)
microSMD500LR	3,000	15,000	⊥	2.65 (0.104)	1.00 (0.039)	2.00 (0.079)
microSMD550LR	3,000	15,000	⊥	2.65 (0.104)	1.00 (0.039)	2.00 (0.079)
microSMD600LR	3,000	15,000	V	2.65 (0.104)	1.10 (0.043)	2.00 (0.079)

Part Numbering System

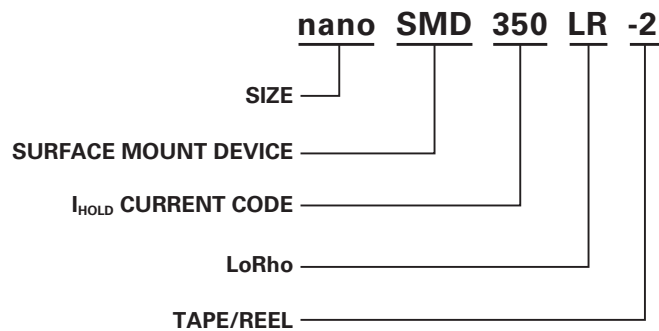

Tape and Reel Specifications

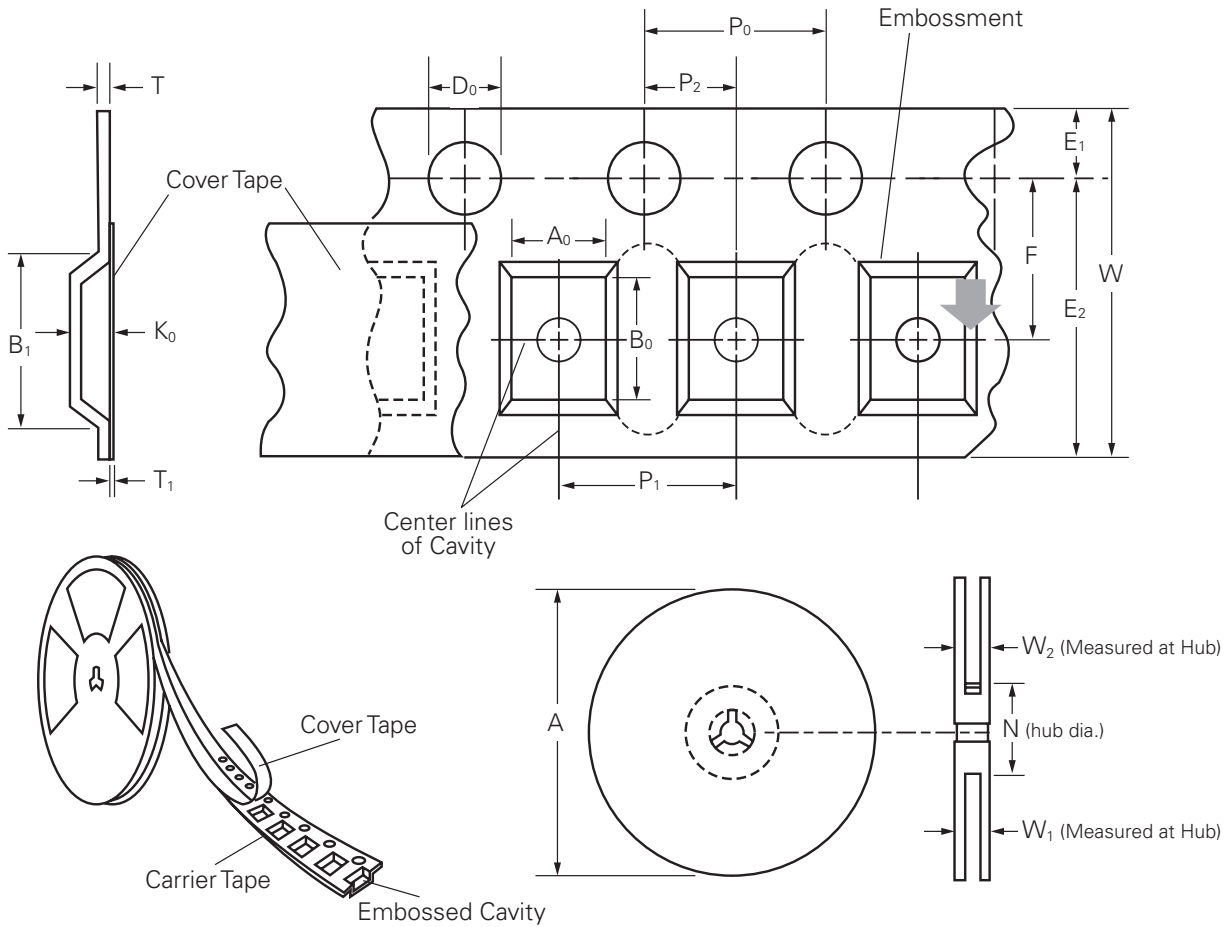

Description	nanoSMDLR Series	microSMDLR Series
	EIA 481-1	EIA 481-1
W	8.0 ± 0.30	8.0 ± 0.30
P₀	4.0 ± 0.10	4.0 ± 0.10
P₁	4.0 ± 0.10	4.0 ± 0.10
P₂	2.0 ± 0.05	2.0 ± 0.05
A₀	1.95 ± 0.10	2.9 ± 0.10
B₀	3.50 +0.1/-0.08	3.55 ± 0.10
B₁ mAx	4.35	4.35
D₀	1.55 ± 0.05	1.55 ± 0.05
F	3.50 ± 0.05	3.50 ± 0.05
E₁	1.75 ± 0.10	1.75 ± 0.10
E₂ min	6.25	6.25
T mAx	0.3	0.3
T₁ mAx	0.1	0.1
K₀	0.89 ± 0.10	1.27 ± 0.10
A mAx	185	185
n min	50	50
W₁	12.4 + 2.0/-0.00	12.4 + 2.0/-0.00
W₂ mAx	14.4	14.4

Standard Pack Quantity: 3,000 pcs
Minimum Order Quantity: 15,000 pcs

Installation and Handling Guidelines

- Operation of these devices beyond the stated maximum ratings could result in damage to the devices and lead to electrical arcing and/or fire.
- These devices are intended to protect against the effects of temporary over-current or over-temperature conditions and are not intended to perform as protective devices where such conditions are expected to be repetitive or prolonged in duration.
- Exposure to silicon-based oils, solvents, electrolytes, acids, and similar materials can adversely affect the performance of these PPTC devices.
- These devices undergo thermal expansion under fault conditions, and thus shall be provided with adequate space and be protected against mechanical stresses.
- Circuits with inductance may generate a voltage ($L di/dt$) above the rated voltage of the PPTC device.
- Hand-soldering of PTC devices on boards is generally not recommended. Users shall define and verify this process if needed.
- Consult Littelfuse when the device is to be applied with thermal processes other than reflow process on the circuit board, such as molding, encapsulation. User should evaluate molding materials used in the charging cable applications to ensure there are no adverse effect on the PTC devices.

Warning

- Users should independently evaluate the suitability of and test each product selected for their own application.
- Operation beyond the maximum ratings or improper use may result in device damage and possible electrical arcing and flame.
- These devices are intended for protection against damage caused by occasional overcurrent or overtemperature fault conditions and should not be used when repeated fault conditions or prolonged trip events are anticipated.
- Contamination of the PPTC material with certain silicone-based oils or some aggressive solvents can adversely impact the performance of the devices.
- Device performance can be impacted negatively if devices are handled in a manner inconsistent with recommended electronic, thermal, and mechanical procedures for electronic components.
- PPTC devices are not recommended for installation in applications where the device is constrained such that its PTC properties are inhibited, for example in rigid potting materials or in rigid housings, which lack adequate clearance to accommodate device expansion.
- Operation in circuits with a large inductance can generate a circuit voltage ($L di/dt$) above the rated voltage of the device.

Disclaimer Notice

Information furnished is believed to be accurate and reliable. However, users should independently evaluate the suitability of and test each product selected for their own applications. Littelfuse products are not designed for, and shall not be used for, any purpose (including, without limitation, military, aerospace, medical, life-saving, life-sustaining or nuclear facility applications, devices intended for surgical implant into the body, or any other application in which the failure or lack of desired operation of the product may result in personal injury, death, or property damage) other than those expressly set forth in applicable Littelfuse product documentation. Warranties granted by Littelfuse shall be deemed void for products used for any purpose not expressly set forth in applicable Littelfuse documentation. Littelfuse shall not be liable for any claims or damages arising out of products used in applications not expressly intended by Littelfuse as set forth in applicable Littelfuse documentation. The sale and use of Littelfuse products is subject to Littelfuse Terms and Conditions of Sale, unless otherwise agreed by Littelfuse.