

Universal Replacement Television Stand

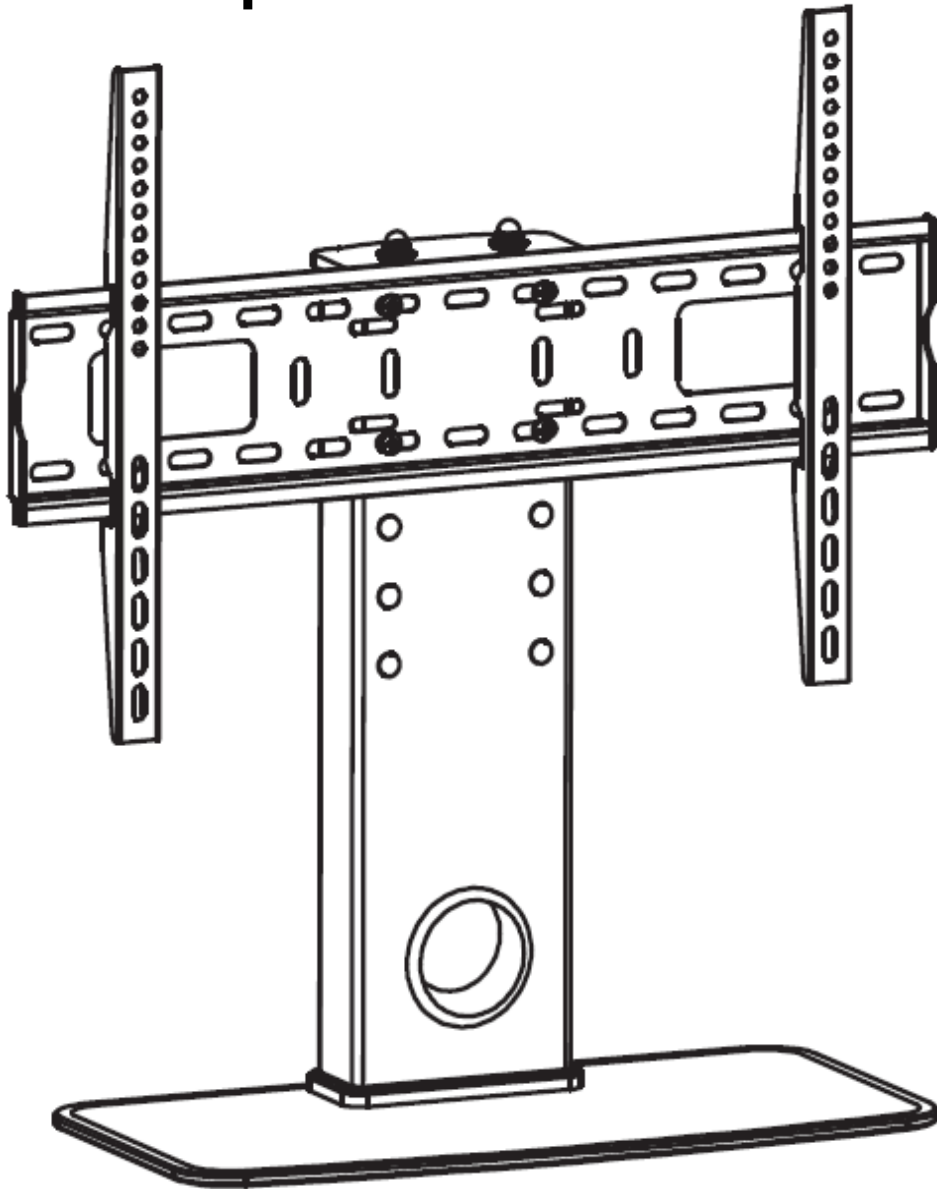

Assembly / Use Manual

This universal replacement television base is intended use with televisions with 60" diagonal screen measurement or less, and weighing less than 60 pounds. Please note that televisions differ greatly in size and weight distribution, and no two installation circumstances are the same. It is the users responsibility to ensure suitability of this product for each individual situation.

Please read this document completely prior to use.

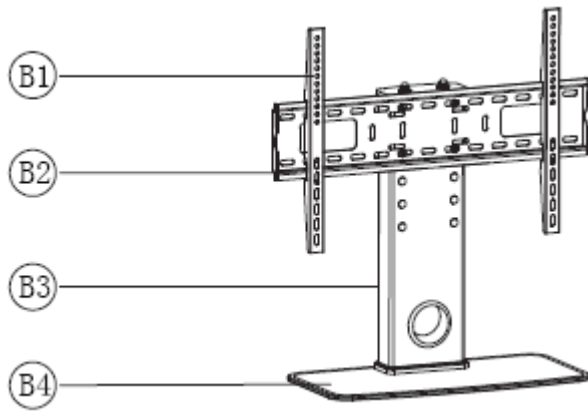

A1	x2		
A2	x2	A3	x2
A4	x2	A5	x8
A6	x4	A7	x4
A8	x4	A9	x14
A10	x2	A11	x1

Identify and verify all of the included hardware

When unpacking the hardware, note that the glass base (B4) and rear pedestal (B3) and all associated hardware are in the main outer box. Inside the sub box you will find the wall mount pieces (B1 x 2) and (B2).

To begin, place the glass base (B4) on a flat surface with the shiny side facing upwards.

Locate the following parts:

- Rear pedestal (B3)
- (2) support rods (A1)
- (2) plastic end caps (A10). Plastic end caps are intended to attach to both sides of the rear pedestal.
- Metal top plate (A11)
- (2) Cap nuts (A2)
- (2) Metal washers (A3) – outside diameter 3/4"
- (2) Plastic washers (A4) – outside diameter 3/4"

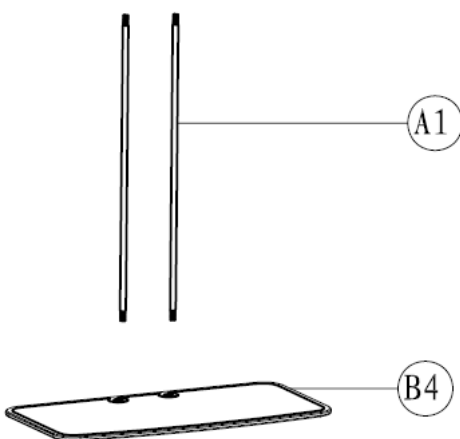

Step One:

Insert both rods (A1) into the appropriate threaded openings in the glass base. Using a pair of pliers, tighten the rods until they are just snug.

Take one plastic end cap and place over the rod, so the opening for the pedestal is facing upward. The rounded edge of the end cap will also face upward.

Step Two:

Slide the rear pedestal over the support rods and insert into the end cap that is resting on the glass base.

Place the second end cap on the top of the rear pedestal with rounded edges of the end cap facing down.

The support rods will protrude through the end cap.

Place the metal top plate on top of the plastic end cap with the support rods protruding through the two holes.

Over both support rods, place plastic washers (A4) then metal washers (A3).

Screw cap nuts (A2) onto the support rods. Tighten only until snug onto the rods. Pliers or a wrench should be used for this, however be extremely careful not to over tighten as this may break the glass base.

Step Three:

Locate the rear wall mount bracket (B2).

Determine the optimum height on the rear pedestal to attach the (B2) bracket. The best method to do this is to measure from the center of your television screen to the bottom most edge of the TV set. This will tell you the minimum clearance needed on this Universal Base.

The vertical center of the (B2) bracket must be at least 1" higher from the base than your measurement taken on your television. This will ensure you have enough clearance for proper ventilation. It is also important to consider any TV controls, connections or attached cables that may require clearance.

Locate four (A8) philips head screws and four (A5) metal washers. Slide each washer onto the (A8) screw.

Attach the bracket (B2) to the rear pedestal (B3) by sliding the four (A8) screws through the appropriate holes in the rear pedestal. Make sure the bracket is horizontally centered.

The (A8) screws will protrude from the rear of the pedestal. Slide first a plastic washer (A6) then metal washer (A5) onto each of the screws. Then attach a wingnut (A7) to each of the (A8) screws and firmly hand tighten.

Notice exposed mounting holes in the rear pedestal. If desired These can be filled with the plastic fill plugs (A9) provided. Note that once the TV is installed, these holes will not be visible.

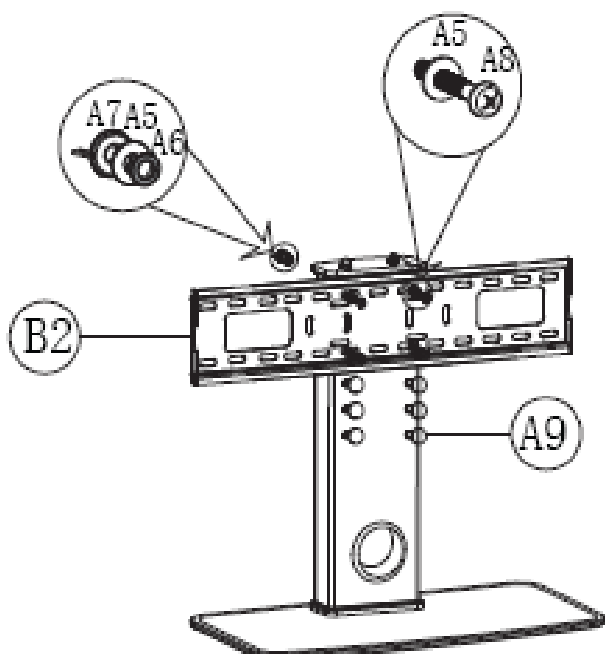
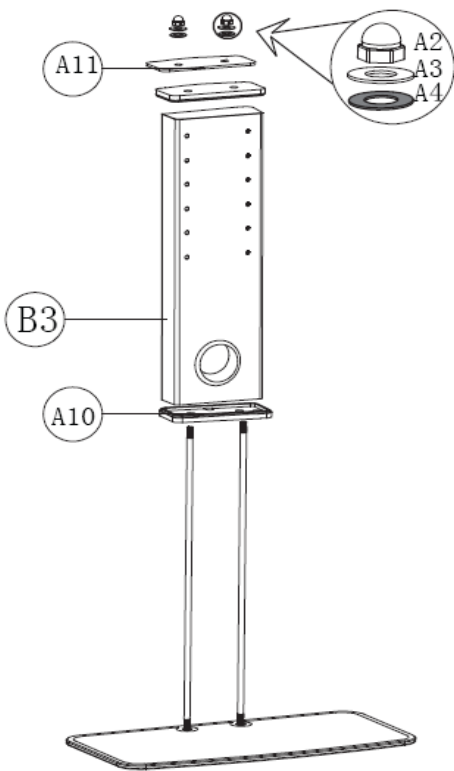



Step Four:

Locate the two television mounting brackets (B1).

These brackets attach to the rear mounting points on most VESA standard television sets. These are compatible with VESA sizes up to 600 x 400. Using the screws and washers provided, these will be attached to the rear of your television set. As all sets differ slightly, it is not possible to provide exact instruction in this document. If possible, you should refer to your television owner's manual for this.

Many different screw sizes are provided to accommodate most every television in the market. The critical issue is to choose screws that are the correct TPI (threads), diameter, and appropriate length.

Choosing a screw that is too short will cause the mount to not support the set. Choosing a screw that is too long may cause you to insert too far into the rear of your set, thus damaging internal components.

Attach the (B1) brackets to the rear of your set and be certain all screws are properly and securely inserted.

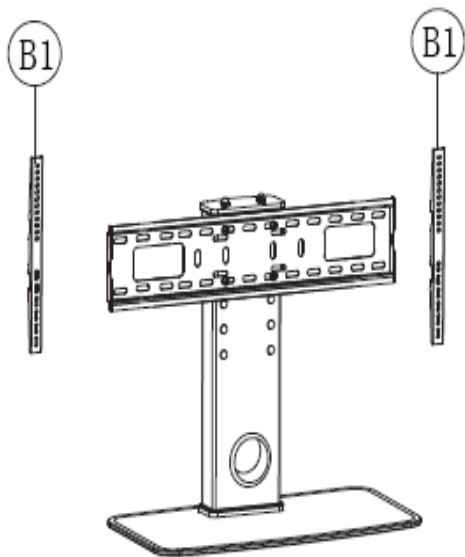

Step Five:

On the rear of the (B1) brackets, locate the attachment set screws facing downward. These secure the television to the assembled stand. Fully loosen these screws until they are just in their threaded holes.

It is now time to hang the television onto the base. For larger sets this will require two people.

Hook the top of the (B1) bracket on to the (B2) portion of the assembled stand. The (B1) bracket will hang on the top lip of the (B2) bracket, with the set screws tightening against the bottom lip. Tighten the screws against the bottom lip and test the set to make sure it is secure.

This completes the assembly steps of this stand.

As noted earlier, it is the ultimate responsibility of the user to ensure safe and secure installation of any television on this stand. There is no guarantee that every television, even if within the size and weight limits specified, will be secure in every situation.

Once installation is complete, the user must make certain the television set is secure. Failure to do so could result in property damage, electrical or fire hazard and personal injury or death, should the television fall. Pro Signal, MCM Electronics and all retail dealers providing this product cannot be held liable for damages that result from improper or insecure installation.

Things to remember:

Furniture including tables, dressers, entertainment centers and shelves must be tested to ensure stability

Televisions should be installed out of reach of small children or pets that could potentially pull or knock a set from its location

Connecting cables, including power cords, cable, antenna or satellite TV wires, cables from other components, indoor antennas and similar items should be secured and tucked out of the way to prevent being snagged or tripped over

Televisions should not be located in direct sunlight or in locations where they can come in contact with rain or moisture.

To provide added security, a Television Security Cable Kit, such as the Pro Signal Model #50-14725 should be considered. A simple internet search should quickly identify numerous places where this kit may be found.

In the event the user is not confident in the safety of this installation it is highly recommended that a qualified installation professional be contacted.

Warranty

This device is warranted against manufactures defects for a period of 1 year from the original date of purchase. This warranty covers all internal components and the cost of labor to either repair or replace the unit. This warranty covers only the unit, and does not cover connected equipment, or any loss that may occur, regardless of cause. It will be the sole discretion of MCM Electronics to determine the applicability of said warranty, and determination as to whether the unit will be repaired or replaced. Questions regarding application, use, or problems with this unit should be directed to MCM Electronics Tech Support, which can be found at www.mcmelectronics.com.