

# POWER SUPPLY KIT

MODEL XP-620K



7 56619 00049 7



Assembly and Instruction Manual

**Elenco™ Electronics, Inc.**

## PARTS LIST

If any parts are missing or damaged, see instructor or bookstore. **DO NOT** contact your place of purchase as they will not be able to help you. Contact Elenco™ Electronics (address/phone/e-mail is at the back of this manual) for additional assistance, if needed.

### RESISTORS

Qty.	Symbol	Value	Color Code	Part #
<input type="checkbox"/> 1	R5	.18Ω 5% 3W		101804
<input type="checkbox"/> 2	R3, R4	2.7Ω 5% 1/2W	red-violet-gold-gold	112701
<input type="checkbox"/> 2	R1, R2	150Ω 5% 1/4W	brown-green-brown-gold	131500
<input type="checkbox"/> 2	VR1, VR2	2kΩ Potentiometer		192422

### CAPACITORS

Qty.	Symbol	Value	Description	Part #
<input type="checkbox"/> 5	C1 - C4, C8	10μF	Electrolytic	271045
<input type="checkbox"/> 2	C5, C6	2200μF	Electrolytic	292226
<input type="checkbox"/> 1	C7	4700μF	Electrolytic	294744







### SEMICONDUCTORS

Qty.	Symbol	Value	Description	Part #
<input type="checkbox"/> 4	D1 - D4	1N4001	Diode	314001
<input type="checkbox"/> 4	D5 - D8	1N5400	Diode	315400
<input type="checkbox"/> 1	Q1	A70	Transistor PNP	320070
<input type="checkbox"/> 1	Q2	2N6124	Transistor PNP	326124
<input type="checkbox"/> 1	IC1	LM-317	Integrated Circuit	330317
<input type="checkbox"/> 1	IC2	LM-337	Integrated Circuit	330337
<input type="checkbox"/> 1	IC3	LM-7805	Integrated Circuit	337805

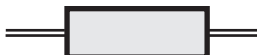
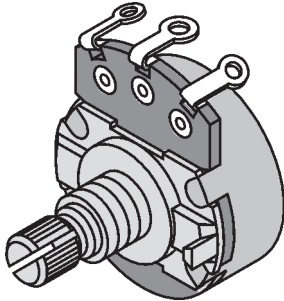
### MISCELLANEOUS

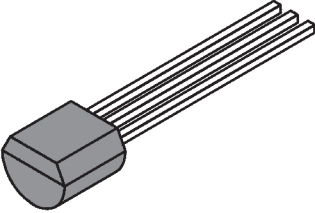
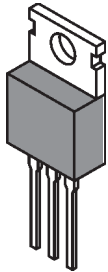
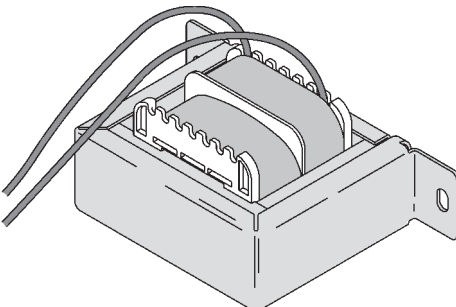
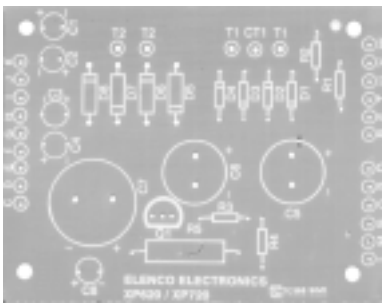
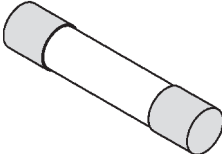
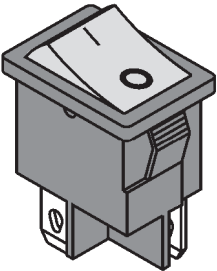
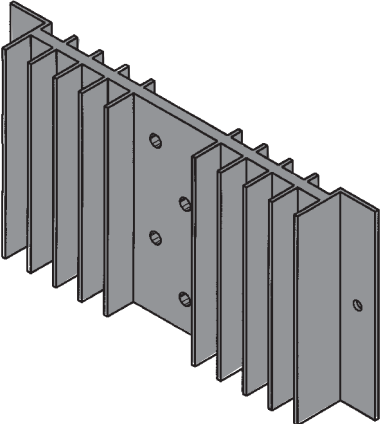
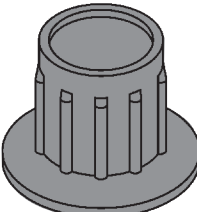
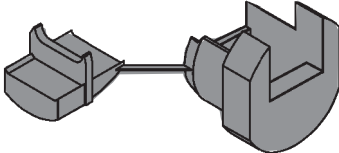
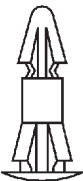
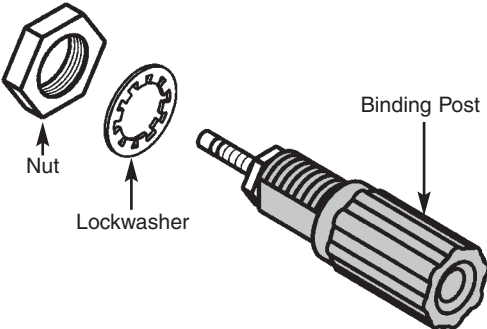
Qty.	Description	Part#	Qty.	Description	Part#
<input type="checkbox"/> 1	Transformer	440720	<input type="checkbox"/> 1	Nut 6-32 Large	644600
<input type="checkbox"/> 1	PC Board	512013	<input type="checkbox"/> 4	Nut 6-32 Small	644601
<input type="checkbox"/> 1	Fuse 1.25A	530125	<input type="checkbox"/> 2	Nut 8-32	644800
<input type="checkbox"/> 1	Rocker Switch	541204	<input type="checkbox"/> 2	Flat Washer 8mm x 14mm	645101
<input type="checkbox"/> 1	Cover	611120	<input type="checkbox"/> 2	Lockwasher 5/16"	646101
<input type="checkbox"/> 1	Chassis	612020	<input type="checkbox"/> 2	Lockwasher #8	646828
<input type="checkbox"/> 1	Heat Sink	615010	<input type="checkbox"/> 4	Rubber Feet	662003
<input type="checkbox"/> 2	Knob	622009	<input type="checkbox"/> 1	Fuse Holder Body	663005LB
<input type="checkbox"/> 1	Strain Relief	624003	<input type="checkbox"/> 1	Fuse Holder Nut	663005N
<input type="checkbox"/> 5	Insulating Washer	624007	<input type="checkbox"/> 1	Fuse Holder Cap	663005UB
<input type="checkbox"/> 4	PC Board Stand-off	625001	<input type="checkbox"/> 1	Fuse Holder Washer	663005W
<input type="checkbox"/> 2	Black Binding Post	625031	<input type="checkbox"/> 3	Mica Insulator	780002
<input type="checkbox"/> 5	Lockwasher, Binding Post	625031LW	<input type="checkbox"/> 1	Silicon Grease	790005
<input type="checkbox"/> 5	Nut, Binding Post	625031HN	<input type="checkbox"/> 6"	20 Ga. Red Wire	813210
<input type="checkbox"/> 2	Red Binding Post	625032	<input type="checkbox"/> 48"	22 Ga. Red Wire	814201
<input type="checkbox"/> 1	Yellow Binding Post	625034	<input type="checkbox"/> 48"	22 Ga. Orange Wire	814310
<input type="checkbox"/> 5	Screw 6-32 x 3/8" Phillips	641640	<input type="checkbox"/> 48"	22 Ga. Blue Wire	814610
<input type="checkbox"/> 2	Screw 8-32 x 3/8" Phillips	641840	<input type="checkbox"/> 1	Line Cord	862105
<input type="checkbox"/> 4	Screw #6 x 3/8" Black Truss Head	642652	<input type="checkbox"/> 2"	Shrink Tubing 1/2" Dia.	891101
<input type="checkbox"/> 2	Screw #6 x 3/8" black AB Phillips	642660	<input type="checkbox"/> 1.5"	Shrink Tubing 3/4" Dia.	899110
<input type="checkbox"/> 2	Nut 7mm	644101	<input type="checkbox"/> 1	Solder Tube	9ST4

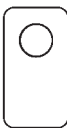
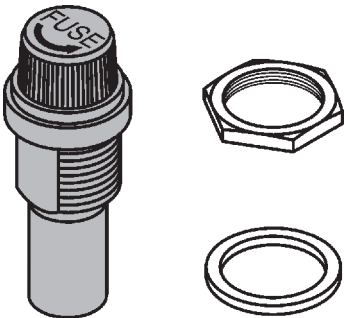
# PARTS IDENTIFICATION

<p><b>Resistor</b></p>  <p><b>.18Ω 3W Resistor</b></p> 	<p><b>2kΩ Potentiometer</b></p> 	<p><b>Capacitor</b></p> 	<p><b>Diode</b></p> 	<p><b>Transistor</b></p> 
<p><b>Integrated Circuit</b></p> 	<p><b>Transformer</b></p> 	<p><b>PC Board</b></p> 	<p><b>Fuse</b></p> 	
<p><b>Switch</b></p> 	<p><b>Heatsink</b></p> 	<p><b>Knob</b></p> 	<p><b>Strain Relief</b></p>  <p><b>PC Board Stand-off</b></p> 	
<p><b>Binding Post Assembly</b></p>  <p>Nut</p> <p>Lockwasher</p> <p>Binding Post</p>	<p><b>Nuts</b></p>  <p>7mm      6-32 / 8-32</p>	<p><b>Mica</b></p> 	<p><b>Fuse Assembly</b></p> 	
<p><b>Flat Washer</b></p> 	<p><b>Lockwashers</b></p>  <p>#8      5/16"</p>			

## IDENTIFYING RESISTOR VALUES

Use the following information as a guide in properly identifying the value of resistors.

BAND 1 1st Digit		BAND 2 2nd Digit		Multiplier		Resistance Tolerance	
Color	Digit	Color	Digit	Color	Multiplier	Color	Tolerance
Black	0	Black	0	Black	1	Silver	$\pm 10\%$
Brown	1	Brown	1	Brown	10	Gold	$\pm 5\%$
Red	2	Red	2	Red	100	Brown	$\pm 1\%$
Orange	3	Orange	3	Orange	1,000	Red	$\pm 2\%$
Yellow	4	Yellow	4	Yellow	10,000	Orange	$\pm 3\%$
Green	5	Green	5	Green	100,000	Green	$\pm 0.5\%$
Blue	6	Blue	6	Blue	1,000,000	Blue	$\pm 0.25\%$
Violet	7	Violet	7	Silver	0.01	Violet	$\pm 0.1\%$
Gray	8	Gray	8	Gold	0.1		
White	9	White	9				

### BANDS

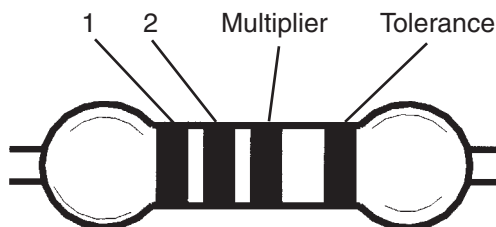

## IDENTIFYING CAPACITOR VALUES

Capacitors will be identified by their capacitance value in pF (picofarads), nF (nanofarads), or  $\mu\text{F}$  (microfarads). Most capacitors will have their actual value printed on them. Some capacitors may have their value printed in the following manner. The maximum operating voltage may also be printed on the capacitor.

Multiplier	For the No.	0	1	2	3	4	5	8	9
	Multiply By		1	10	100	1k	10k	100k	0.01

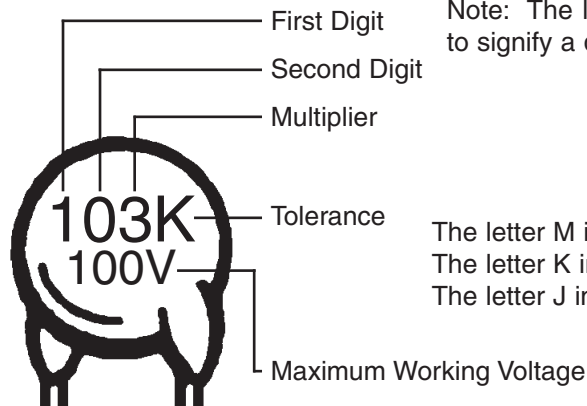

Note: The letter "R" may be used at times to signify a decimal point; as in 3R3 = 3.3

The letter M indicates a tolerance of  $\pm 20\%$   
 The letter K indicates a tolerance of  $\pm 10\%$   
 The letter J indicates a tolerance of  $\pm 5\%$

The value is  $10 \times 1,000 = 10,000\text{pF}$  or  $.01\mu\text{F}$  100V

## METRIC UNITS AND CONVERSIONS

Abbreviation	Means	Multiply Unit By	Or
p	Pico	.000000000001	$10^{-12}$
n	nano	.000000001	$10^{-9}$
$\mu$	micro	.000001	$10^{-6}$
m	milli	.001	$10^{-3}$
-	unit	1	$10^0$
k	kilo	1,000	$10^3$
M	mega	1,000,000	$10^6$

- 1,000 pico units = 1 nano unit
- 1,000 nano units = 1 micro unit
- 1,000 micro units = 1 milli unit
- 1,000 milli units = 1 unit
- 1,000 units = 1 kilo unit
- 1,000 kilo units = 1 mega unit

# CONSTRUCTION

## Introduction

The most important factor in assembling your XP-620K Power Supply Kit is good soldering techniques. Using the proper soldering iron is of prime importance. A small pencil type soldering iron of 25 - 40 watts is recommended. **The tip of the iron must be kept clean at all times and well tinned.**

## Safety Procedures

- Wear eye protection when soldering.
- Locate soldering iron in an area where you do not have to go around it or reach over it.
- **Do not hold solder in your mouth.** Solder contains lead and is a toxic substance. Wash your hands thoroughly after handling solder.
- Be sure that there is adequate ventilation present.

## Assemble Components

In all of the following assembly steps, the components must be installed on the top side of the PC board unless otherwise indicated. The top legend shows where each component goes. The leads pass through the corresponding holes in the board and are soldered on the foil side.

**Use only rosin core solder of 63/37 alloy.**

**DO NOT USE ACID CORE SOLDER!**

## What Good Soldering Looks Like

A good solder connection should be bright, shiny, smooth, and uniformly flowed over all surfaces.

1. Solder all components from the copper foil side only. Push the soldering iron tip against both the lead and the circuit board foil.

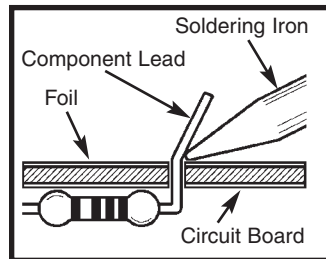

2. Apply a small amount of solder to the iron tip. This allows the heat to leave the iron and onto the foil. Immediately apply solder to the opposite side of the connection, away from the iron. Allow the heated component and the circuit foil to melt the solder.

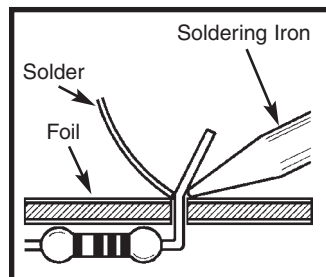

3. Allow the solder to flow around the connection. Then, remove the solder and the iron and let the connection cool. The solder should have flowed smoothly and not lump around the wire lead.

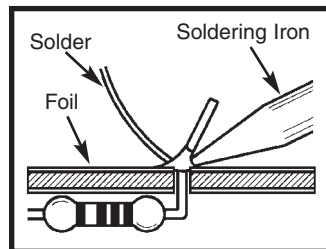

4. Here is what a good solder connection looks like.

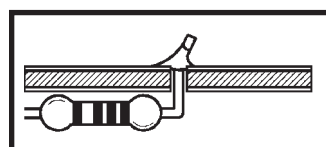

## Types of Poor Soldering Connections

1. **Insufficient heat** - the solder will not flow onto the lead as shown.

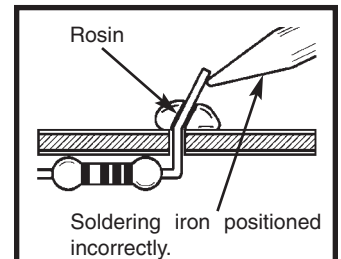

2. **Insufficient solder** - let the solder flow over the connection until it is covered. Use just enough solder to cover the connection.

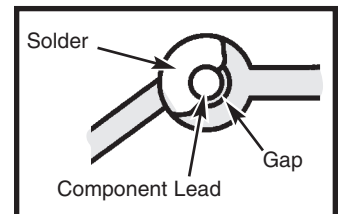

3. **Excessive solder** - could make connections that you did not intend to between adjacent foil areas or terminals.

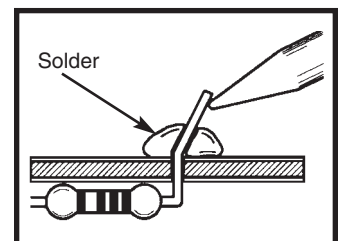

4. **Solder bridges** - occur when solder runs between circuit paths and creates a short circuit. This is usually caused by using too much solder. To correct this, simply drag your soldering iron across the solder bridge as shown.

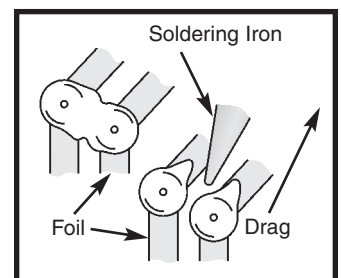

# ASSEMBLE COMPONENTS TO PC BOARD

**Figure A**

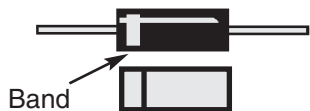

Diodes have polarity. Be sure that the band is in the correct direction.

**Figure B**

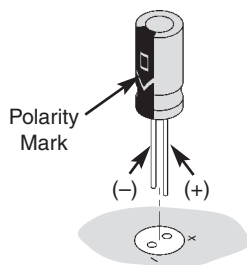

Electrolytics have a polarity marking indicating the (-) lead. The PC board is marked to show the lead position.

**Figure C**

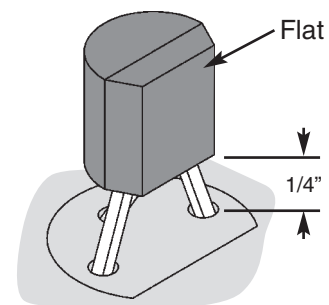

Mount the transistor with the flat side as shown on the top legend. Leave 1/4" between the part and PC board.

- D5 - 1N5400 Diode
  - D6 - 1N5400 Diode
  - D7 - 1N5400 Diode
  - D8 - 1N5400 Diode
- (see Figure A)

- D4 - 1N4001 Diode
  - D3 - 1N4001 Diode
  - D2 - 1N4001 Diode
  - D1 - 1N4001 Diode
- (see Figure A)

- C1 - 10 $\mu$ F Electrolytic
  - C2 - 10 $\mu$ F Electrolytic
  - C3 - 10 $\mu$ F Electrolytic
  - C4 - 10 $\mu$ F Electrolytic
  - C8 - 10 $\mu$ F Electrolytic
- (see Figure B)

- R2 - 150 $\Omega$  Resistor
  - R1 - 150 $\Omega$  Resistor
- (brn-green-brn-gold)

- C6 - 2200 $\mu$ F Electrolytic
  - C5 - 2200 $\mu$ F Electrolytic
- (see Figure B)

- R3 - 2.7 $\Omega$  Resistor
  - R4 - 2.7 $\Omega$  Resistor
- (red-violet-gold-gold)

- C7 - 4700 $\mu$ F Electrolytic
- (see Figure B)

- R5 - .18 $\Omega$  Resistor

- Q1 - A70 Transistor
- (see Figure C)

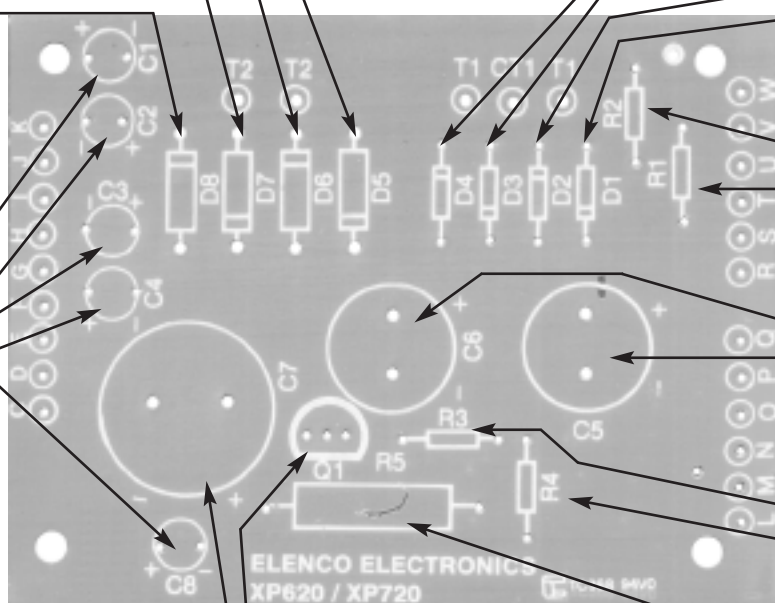

## PC BOARD WIRING

Cut the wires to the required length. Strip 1/4" of insulation off of both ends. Insert the lead into the hole and solder it to the foil side.

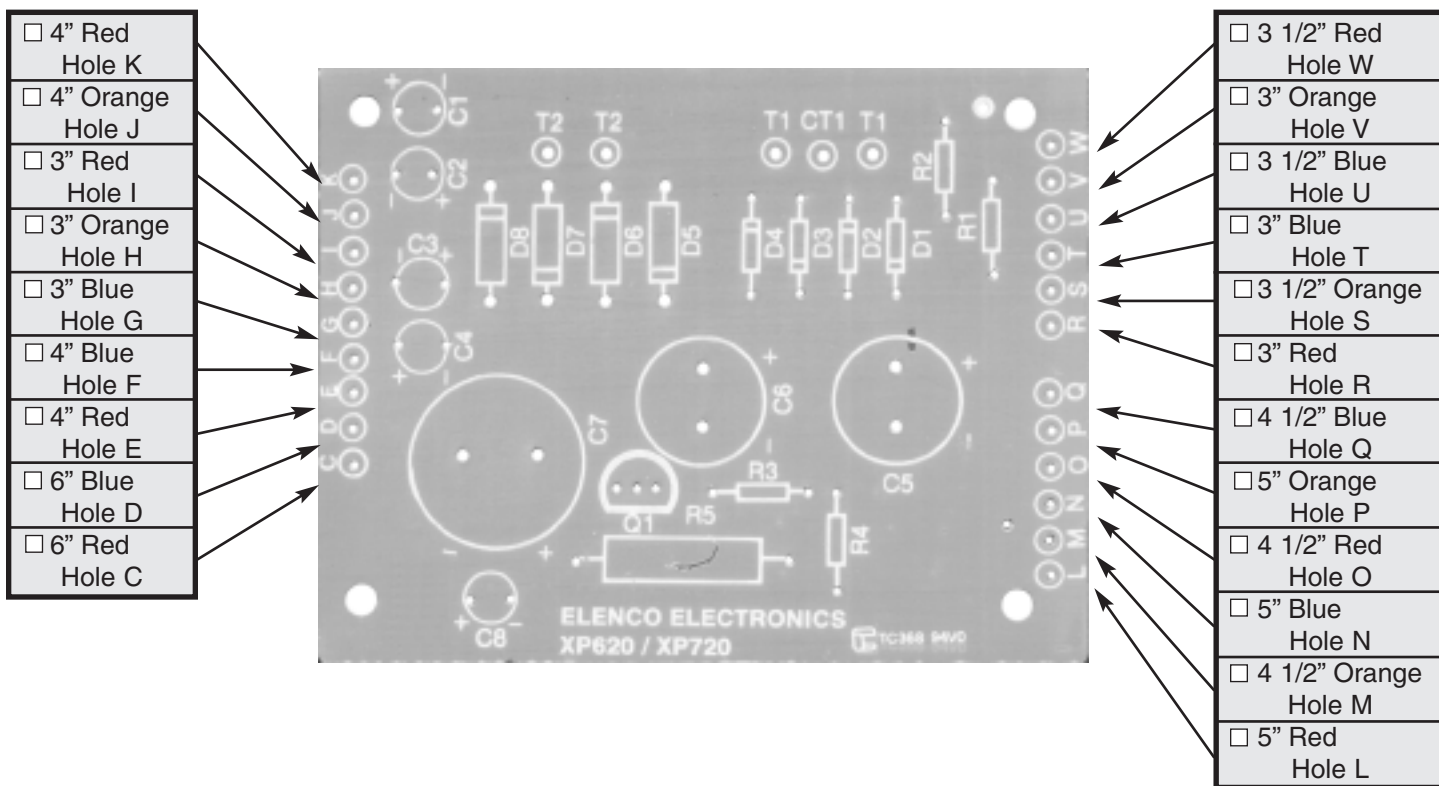

Use this ruler to measure the wires when cutting them to their required lengths.

## PANEL ASSEMBLY

- Install the binding posts with the colors in order, as shown in Figure D. Remove the large nut and splitwasher. Insert the post into the hole and fasten it with the nut and splitwasher. Tighten down the nut with pliers.
- Cut off the tabs on the two potentiometers and install them with the lugs up, as shown in Figure D. Secure in place with a 5/16" lockwasher, 8mm flat washer and 7mm nut.
- Turn both potentiometer shafts all the way counter-clockwise. Line up the line on the knobs with the first line on the voltage scale. Press knobs onto the shaft of the potentiometers.
- Note the lug configuration on the rocker switch. Push the switch into the hole in the chassis with lug 1 on top as shown in Figure D.

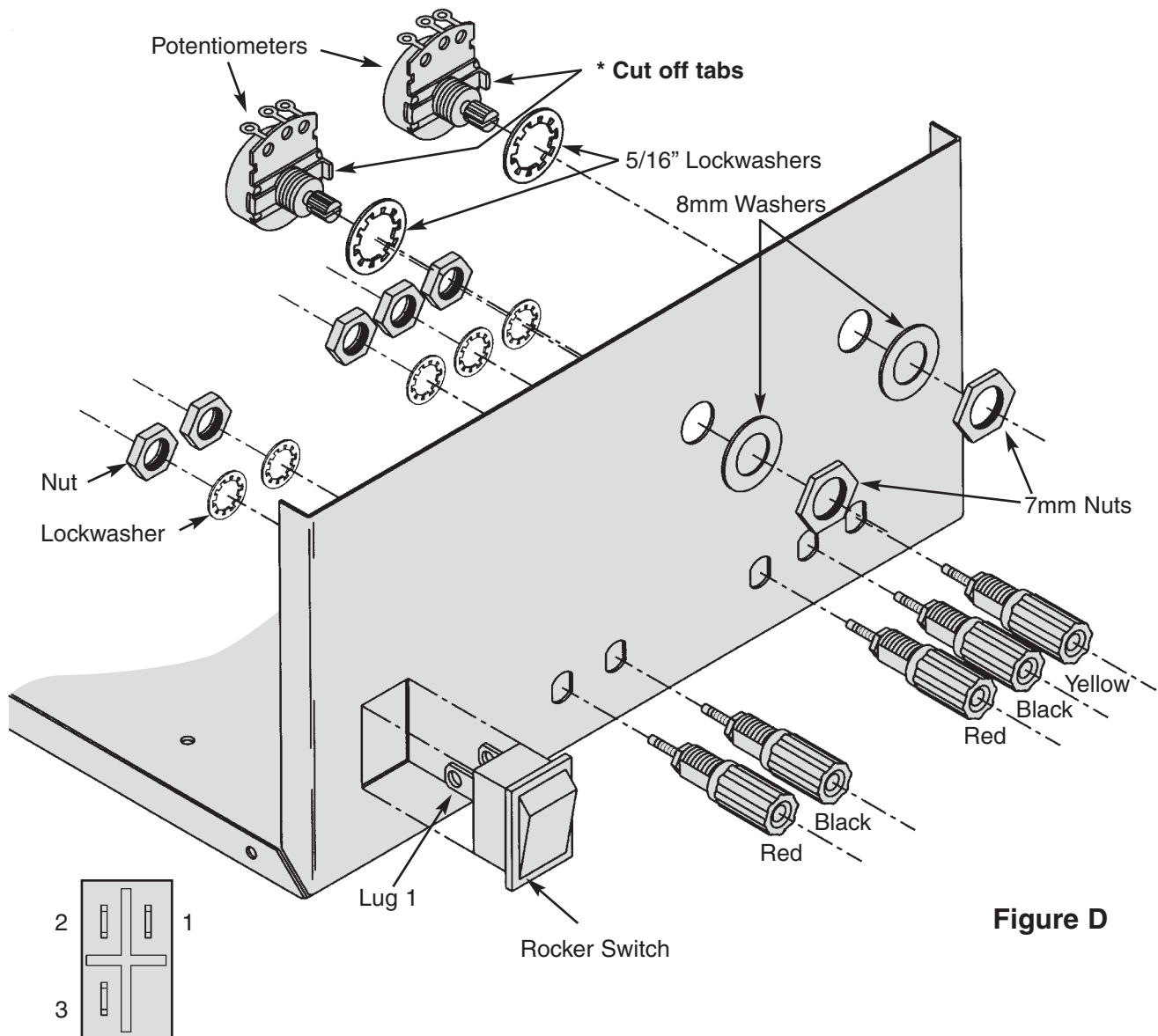

Figure D

Rear View of Rocker Switch



Carefully bend the leads of IC1, IC2, IC3 and Q2 at right angles with pliers.

Install IC1, IC2 and Q2 in the positions shown in Figure E. Fasten in place using the parts shown in Figure F. Spread the silicon grease on the back of the transistor and ICs.

- IC1 - LM-317 IC
- IC2 - LM-337 IC
- Q2 - 2N6124 Transistor

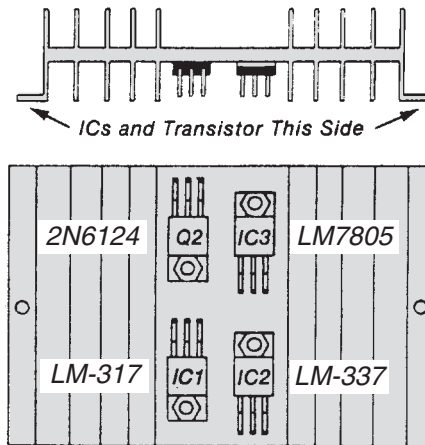
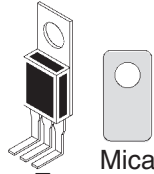

**Figure E**

Install IC3 as shown in Figure Fa.

- IC3 - LM-7805 IC

- Mount the fuse holder to the top hole in the back of the chassis, with the side lug up, as shown in Figure G. Fasten in place with the fuse holder nut. After the holder is secure, insert the fuse and screw the cap on.

- Separate the wires of the line cord 3" from the end. Strip the insulation off the end of all three wires to expose 1/4" of bare wire.

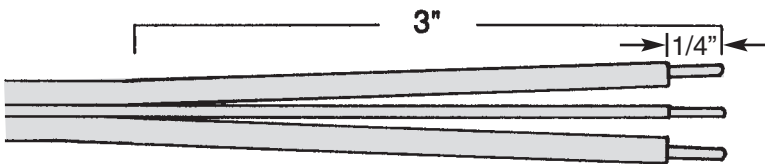

- Insert 6" of the line cord into the bottom hole on the back of the chassis, as shown in Figure G. Place the line cord into the slot of the strain relief and squeeze the two sections together with pliers. Then, insert the strain relief into the hole.

- One side of the transformer has only 2 black wires. Cut these wires so that they are 4 1/2" in length (see Figure H). Strip the insulation off the end of the wires to expose 1/4" of bare wire.

- Cut the red, blue and black wires on the other side of the transformer so that they are 3" in length. Strip the insulation off the end of the wires to expose 1/4" of bare wire.

- Cut the yellow wires flush with the transformer.

- Install the transformer with the black wires side as shown in Figure J. Use an 8-32 x 3/8" screw, #8 lockwasher and an 8-32 nut on each side to fasten in place, as shown in Figure I.

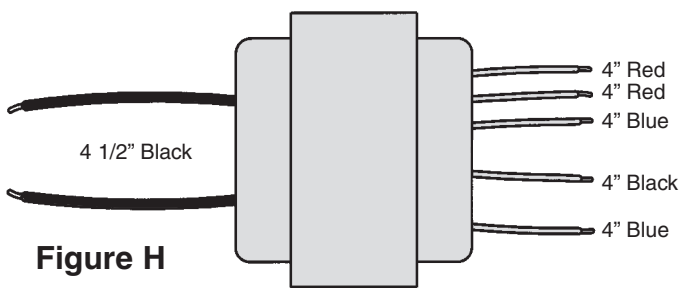

**Figure H**

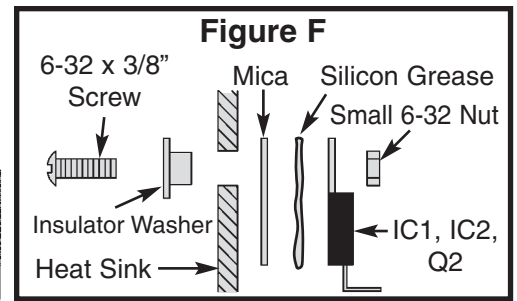

**Figure F**

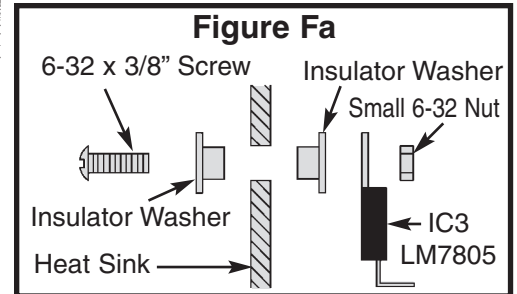

**Figure Fa**

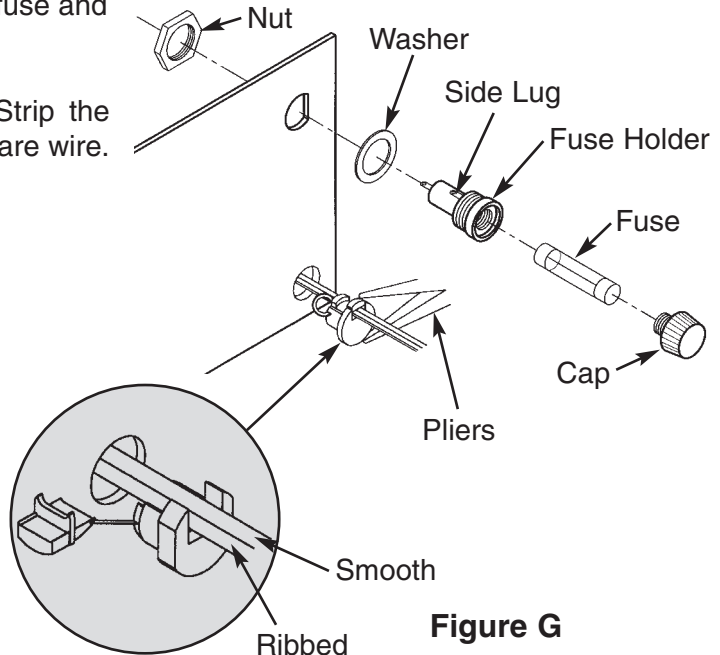

**Figure G**

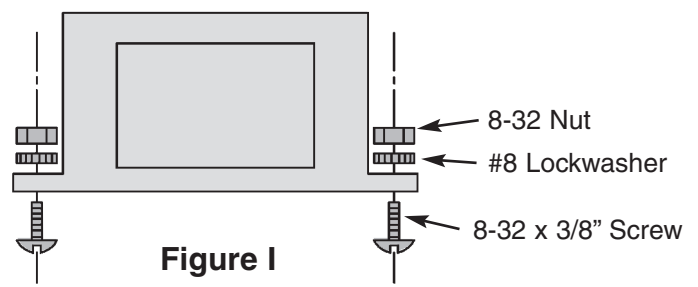

**Figure I**

## WIRING LINE CORD, FUSE, TRANSFORMER AND SWITCH

- Install the line cord ground lug to the chassis using a 6-32 x 3/8" screw and a 6-32 large nut in the location shown in Figure J.
- Strip the insulation off of both ends of the 6" red 20 ga. wire to expose 1/4" of bare wire. Solder one end of the wire to lug 3 on the rocker switch, as shown in Figure J.
- Slip the 2" section of shrink tubing over the other end of the 6" 20 ga. red wire and the smooth or round line cord wire. Solder the line cord wire to the end lug on the fuse holder, as shown in Figure J. Solder the 6" 20 ga. red wire to the side lug on the fuse holder. Slide the shrink tubing over the fuse holder, covering the two lugs. You may use a hair dryer, heat gun (at lowest setting or you will melt the tubing) or the heat emitting from your soldering iron.

**CAUTION: DO NOT** touch any wires or tubing with the iron.

- Slip the 6" strip of red wire (leading from the side lug of the fuse holder), the (A) and (B) black transformer wire, and the ribbed line cord wire through the 3/4" diameter piece of shrink tubing (as shown in Figure J).

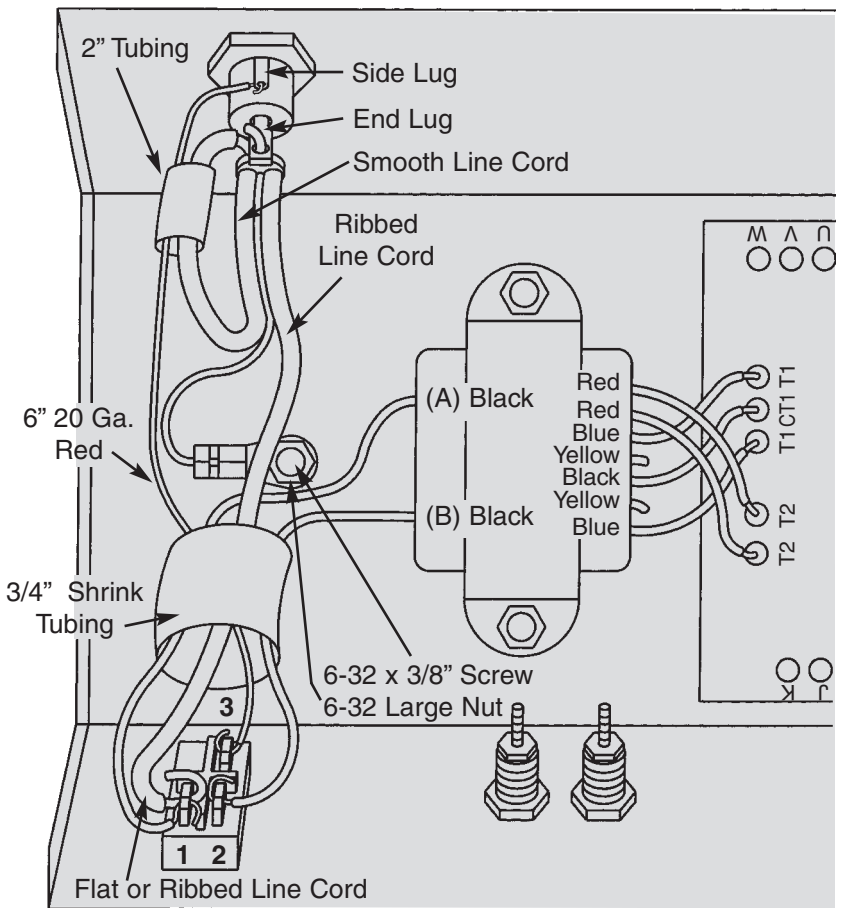

**Figure J**

- Solder the black transformer wire (B), as shown in Figure J to lug 2 on the rocker switch.
- Twist the black transformer wire (A) and the ribbed or flat line cord wire together. Solder the two wires to lug 1 on the rocker switch, as shown in Figure J.
- Slide the 3/4" diameter shrink tubing over the switch and shrink into place.
- Solder the two red transformer wires to the holes marked T2 on the PC board.
- Solder the black transformer wire to the hole marked CT1 on the PC board.
- Solder the two blue transformer wires to the holes marked T1 on the PC board.
- Slowly push the PC board stand-offs into the four holes on the bottom of the chassis. Push the PC board down into place.

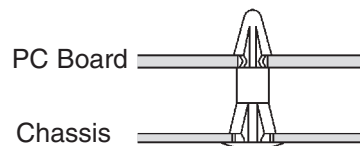

## WIRE BINDING POSTS AND 317, 337

Solder the wires from the board to the binding posts, as shown in Figure K.

- 3" Blue wire from (G) on the PC board; To the Yellow post (-1.5 - 15V).
- 3" Orange wire from (H) on the PC board; To the Black post (common).
- 6" Blue wire from (D) on the PC board; To the Black post (common).
- 6" Red wire from (C) on the PC board; To the Red post (+5V 3A).
- 3" Red wire from (I) on the PC board; To the Red post (+1.5 - 15V).

Place the heat sink with ICs and transistor in the position, as shown in Figure K. Insert the wires from the PC board, through the rectangular hole in the chassis, to the ICs and solder into place.

Tin the leads. Form the end of the wires into a tight loop, for easy, tight connection to leads, before you apply solder.

- 3 1/2" Red wire (W) from PC board; To middle lead of LM-317.
- 3 1/2" Orange wire (S) from PC board; To left lead of LM-317.
- 3 1/2" Blue wire (U) from PC board; To right lead of LM-317.
- 3" Red wire (R) from PC board; To middle lead of LM-337.
- 3" Blue wire (T) from PC board; To left lead of LM-337.
- 3" Orange wire (V) from PC board; To right lead of LM-337.

**After wiring the ICs, be sure that none of the leads touch each other and cause a short.**

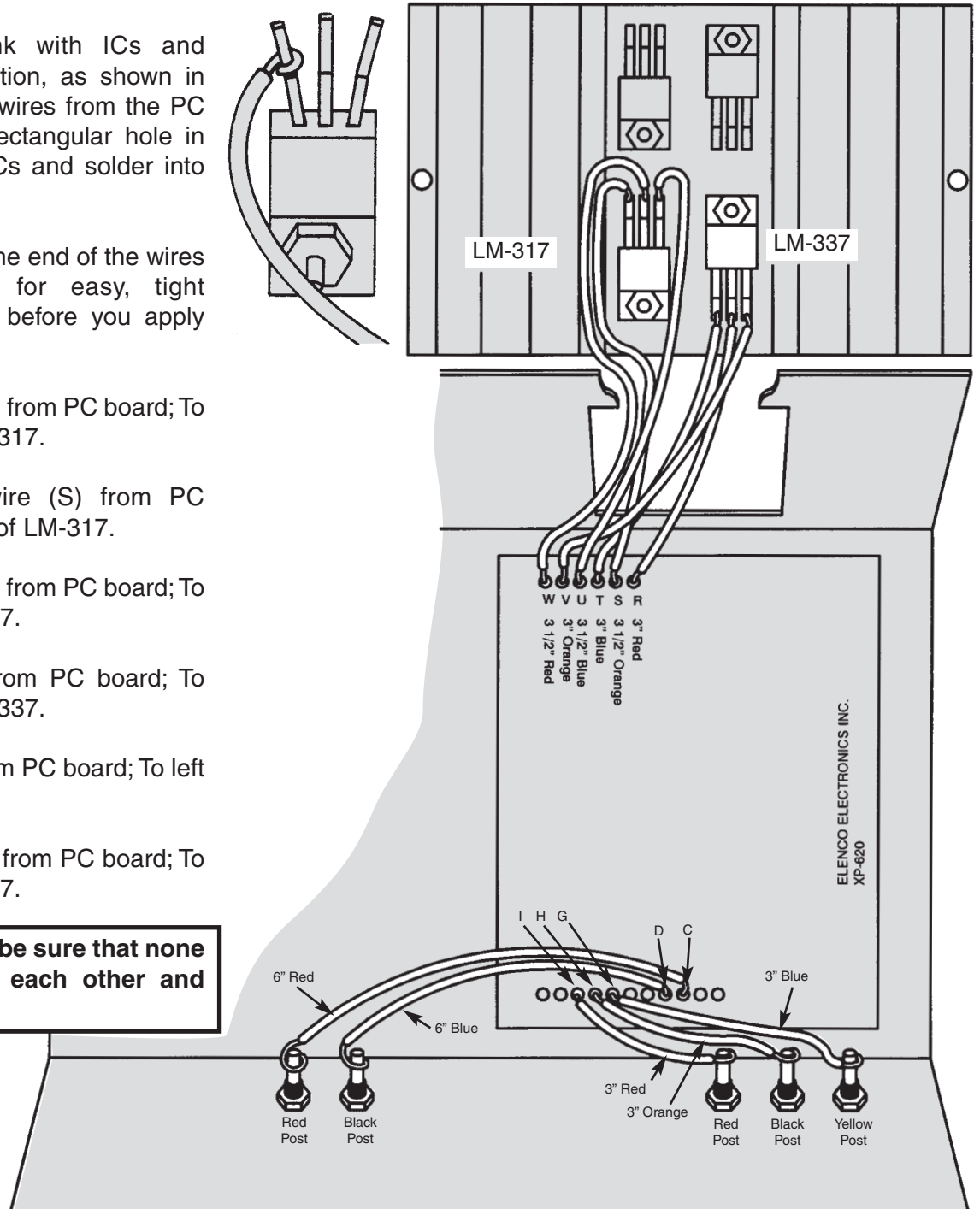

Figure K

## WIRE 2N6124, 7805 & POTENTIOMETERS

Insert the wires from the PC board through the rectangular hole in the chassis to the 2N6124 and LM-7805, solder into place, as shown in Figure L.

- 5" Red wire (L) from the PC board; To middle lead of 2N6124.
- 5" Orange wire (P) from the PC board; to left lead of 2N6124.
- 5" Blue wire (N) from the PC board; to right lead of 2N6124.
- 4 1/2" Red wire (O) from PC board; to middle lead of LM-7805.
- 4 1/2" Blue wire (Q) from PC board; to left lead of LM-7805.
- 4 1/2" Orange Wire (M) from PC board; to right lead of LM-7805.

After wiring, be sure that the leads do not touch each other and cause a short.

Solder the wires from the PC board to the potentiometers, as shown in Figure L.

- 4" Red wire (E) from PC board; to middle lug of the positive voltage pot.
- 4" Blue wire (F) from PC board; to right lug on the positive voltage pot.
- 4" Orange wire (J) from PC board; to middle lug on the negative voltage pot.
- 4" Red wire (K) from PC board; to right lug on negative voltage pot.

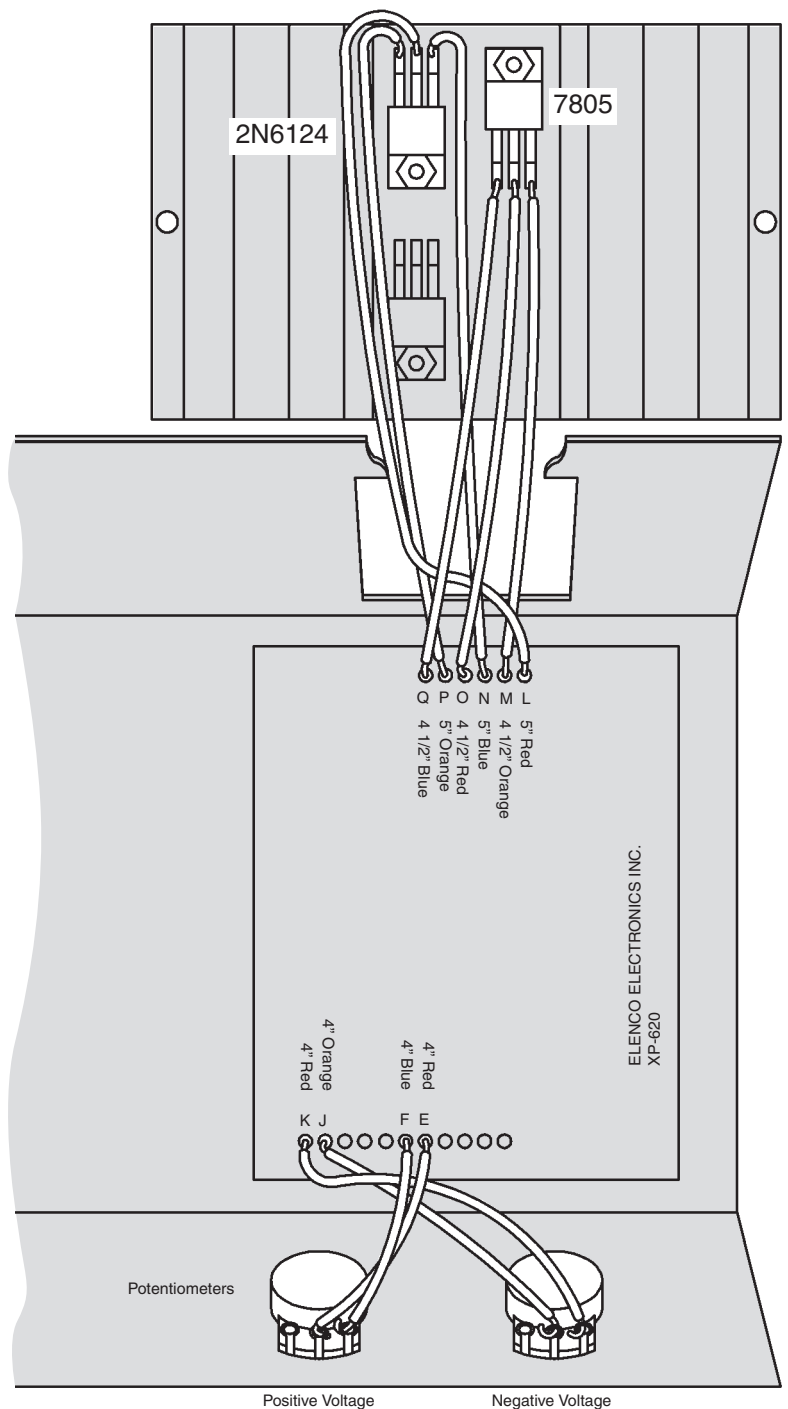
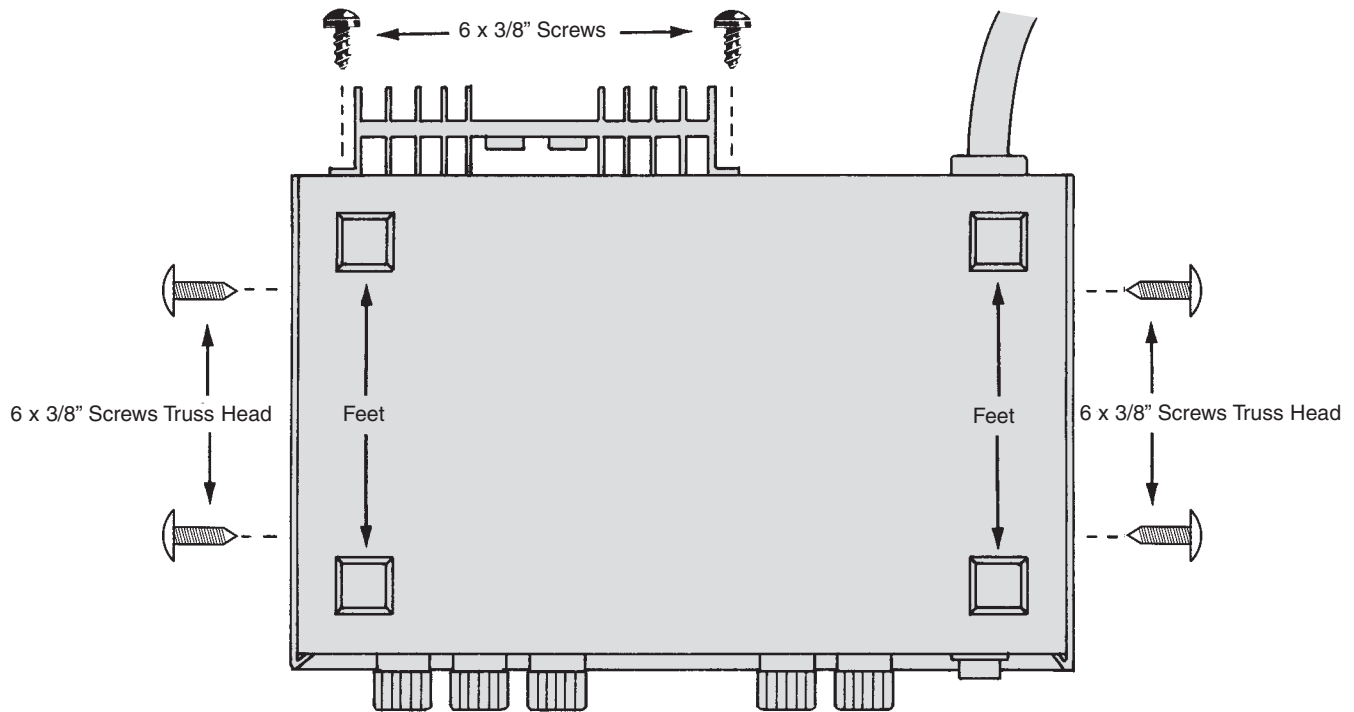

Figure L

---

## FINAL ASSEMBLY

- Fasten the heat sink to the chassis with two 6 x 3/8" black screws, as shown in Figure M.
- Fit the cover onto the chassis. Fasten in place with two 6 x 3/8" truss head black screws on each side, as shown in Figure M.
- Peel off the protective paper from the bottom of the rubber feet and apply one to each corner on the bottom of the chassis, as shown in Figure M.



**Bottom View  
Figure M**

---

## TESTING THE XP-620 POWER SUPPLY

Testing the XP-620 Power Supply is very simple. Before applying power to the unit, be sure that all wiring and soldering is firm. If so, obtain a digital voltmeter. Apply power to the XP-620 and measure the output voltages. The variable voltage supplies should read between 2 and 16 volts. The 5V supply should read between 4.50 and 5.50 volts.

Next, short the output of each supply. They should turn off and recover, when the short is removed. If you have a 10 ohm 10 watt resistor, place it across the output terminal (a 2 watt will work, but use it only a few seconds). The output of the supply should not change more than .2 volts. Do the same on the 5V supply using a 2.5 ohm 12 watt resistor. Again, the output should not change more than .2 volts. In making this test, the voltmeter leads should be clipped to the terminal directly and not to the load leads. This is to prevent errors in voltage drop due to contact resistance of the load.

Should any of these tests fail, please refer to the troubleshooting guide.

---

## **TROUBLESHOOTING GUIDE**

### **No 2 - 15V Output Voltage**

- 1) Check the AC voltage at anode of D1. It should read about 17VAC. If not, check the fuse, transformer, ON/OFF switch or line cord.
- 2) Measure voltage at output of D1. It should read about 24VDC. If not, check D1, D3 and C5.
- 3) If 20V is OK, check IC1.

### **No Negative Voltage Output**

- 1) Check the voltage at the output of D4. It should be -24VDC. Check D2, D4 and C6 and make sure that they are not in backwards.
- 2) If DC is OK, then check IC2.

### **No 5V Output**

- 1) Check the voltage across the transformer winding. It should read about 12 volts. If not, check the diode bridge or C7.
- 2) Measure the DC voltage at the output of the diode bridge. It should read about 12 volts. If not, check the diode bridge or C7.
- 3) If DC is OK, check IC3, Q1 and Q2.

### **Poor Regulation on any Supply**

- 1) Check DC voltage at the input of the regulator. It should be greater than 18 for 2 - 15V output and 8V for 5V output.
- 2) Check AC ripple at the input of the regulator. It should be less than 5V for the variable supply and the 5V supply.
- 3) If the ripple is greater, then check the diodes and its filter capacitor.

### **Fails to Shut Down on 5V Overload**

- 1) Check transistor Q1 and resistors R3, R4 and R5.

### **Unable to Draw 3 Amps at 5 Volts**

- 1) Check transistor Q2 and resistors R3 and R4.

# CIRCUIT DESCRIPTION

## Introduction

The Model XP-620 Power Supply features three solid-state DC power supplies. The first supply gives a negative 1.5 to 15 volts at 1 ampere. The third has a fixed 5V at 3 amperes. All DC supplies are fully regulated. A special IC circuit keeps the output voltage within .2V when going from no load to 1 ampere. The output is fully protected from short circuits. This supply is ideal for use in school labs, service shops or anywhere a precise DC voltage is required.

## The Positive 2-15V Power Supply

Figure 1 shows a simplified circuit diagram of the positive supply. It consists of a power transformer, a DC rectifier stage and the regulator stage.

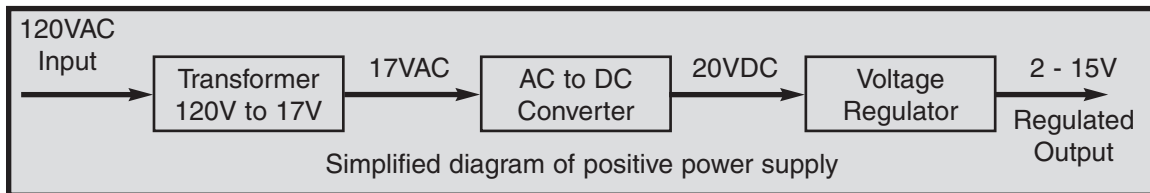

Figure 1

## Transformer

The transformer T1 serves two purposes. First, it reduces the 120VAC input to 17VAC to 8VAC to allow the proper voltage to enter the rectifier stages. Second, it isolates the power supply output from the 120VAC line. This prevents the user from dangerous voltage shock should the user be standing in a grounded area.

## AC to DC Converter

The AC to DC converter consists of diodes D1 and D3 and capacitor C5. Transformer T1 has two secondary windings which are 180 degrees out of phase. The AC output at each winding is shown in Figure 2A and 2B.

Diodes are semiconductor devices that allow current to flow in one direction. The arrow in Figure 3 points to the direction that the current will flow. Only when the transformer voltage is positive will current flow through the diodes. Figure 3 shows the simplest possible rectifier circuit. This circuit is known as a half-wave rectifier. Here the diode conducts only half of the time when the AC wave is positive as shown in Figure 2C. Use of this circuit is simple but inefficient. The big gap between cycles require much more filtering to obtain a smooth DC voltage.

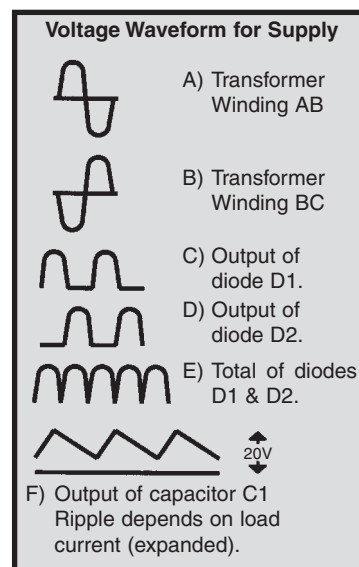

Figure 2

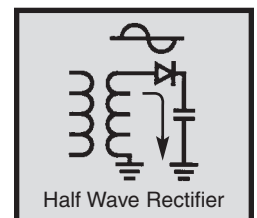

Figure 3

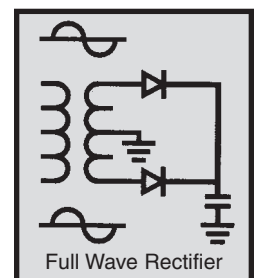

Figure 4

By addition of a second diode and transformer winding, we can fill in the gap between cycles as shown in Figure 4. This circuit is called full-wave rectification. Each diode conducts when the voltage is positive. By adding the two outputs, the voltage presented to capacitor C5 is more complete, thus easier to filter, as shown in Figure 2E. When used in 60 cycles AC input power, the output of a full wave rectifier will be 120 cycles.

Capacitor C5 is used to store the current charges, thus smoothing the DC voltage. The larger the capacitor, the more current is stored. In this design, 2200 $\mu$ F capacitors are used, which allows about 3 volts AC ripple when one amp is drawn.

In practice, the current through the diodes is not as shown in Figure 2C. Because capacitor C5 has a charge after the first cycle, the diode will not conduct until the positive AC voltage exceeds the positive charge in the capacitor. Figure 5 shows a better picture of what the current flow looks like, assuming no loss in the diode.

It takes a few cycles for the voltage to build up on the capacitor. This depends on the resistance of the winding and diode. After the initial start-up, there will be a charge and discharge on the capacitor depending on the current drawn by the output load. Remember current only flows through the diode when the anode is more positive than the cathode. Thus, current will flow in short bursts as shown in Figure 5C.

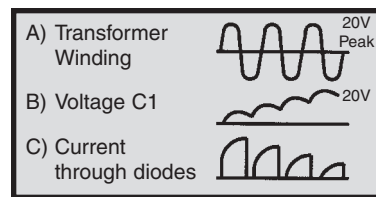

**Figure 5**

The DC load current may be one ampere, but the peak diode current may be three times that. Therefore, the diode rating must be sufficient to handle the peak current. The 1N4001 has peak current rating of 10 amps.

### Regulator Circuit

The regulator circuit in the Model XP-620 Power Supply consists of a LM-317 integrated circuit. This IC is specially designed to perform the regulation function. Figure 6 shows a simplified circuit of how the LM-317 IC works.

Transistors Q1 and Q2 form a circuit known as a differential amplifier. Transistor Q1 base is connected to a stable 1.5V reference voltage. The base of Q2 is connected to the regulator output circuit through a voltage divider network. The collector of transistor Q2 is connected to a current source. This basically is a PNP transistor biased to draw about 1mA of current. Transistor Q2 sees the current source as a very high resistor of about 1 meg ohms. Thus, the gain of transistor Q2 is extremely high.

Transistor Q5 is called the pass transistor. It controls the current reaching the output. Transistors Q3 and Q4 are emitter followers. Their function is to raise the impedance of the pass transistor. Note that transistors Q2, Q3, Q4 and Q5 and resistor R1 form a close loop. Also, note that the feedback to the base of Q2 is negative, that is, when the base of Q2 goes positive, the output at emitter Q5 goes negative. Now if the 2V output voltage goes down because of current drain at the output, the base of Q2 will drop forcing the collector voltage of Q2 to go higher. This will bring the output voltage back to 2V. This is the basis of all negative feedback regulators.

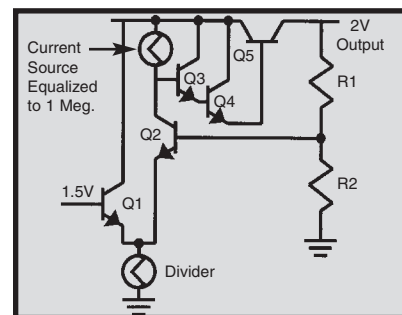
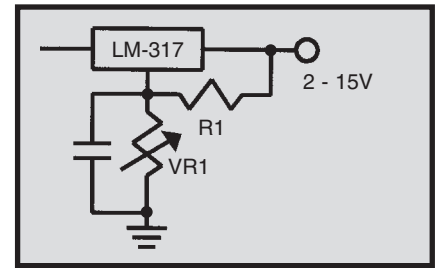

**Figure 6**

Another feature of the LM-317 regulator is to protect the IC against overload and output shorts. If the IC is overloaded, the junction of an overload transistor will overheat. A transistor will sense this overheating and shut down transistor Q5.



The LM-317 IC is basically a 2V regulator. To be able to vary the output 2 - 15V, we stack the IC on a DC voltage as shown in Figure 6A. When VR1 equals 0, the output voltage is 2V as determined by the LM-317 IC. Note that the voltage across R1 is always 2 volts. When R1 equals VR1, the voltage across VR1 will equal the two volts across R1, therefore, the output voltage will be four volts. When VR1 is 5 times R1, the output voltage is 12 volts. As you can see, varying resistor VR1 will vary the voltage from 2V to 15V.



**Figure 6A**

### The Negative Voltage Regulator

The theory of the negative voltage regulator is the same as the previously discussed positive regulator. The basic differences is that diodes D2 and D4 are reversed, producing a negative voltage across capacitor C6. The LM-337 IC is designed to operate from a negative supply.

### The 5 Volt Power Supply

In the previous discussion of the variable voltage regulators, the ICs can handle about 1A of current. In the design of the 5V supply, we need 3A of current. To meet this current requirement we must add an external pass transistor capable of delivering 3A.

Figure 7 shows a simplified 5V regulator with an external PNP pass transistor. In this circuit, transistor Q1 is a power transistor capable of delivering over 3A. Transistor Q2 is biased off until the LM-7805 IC draws about .2A. When .2A is drawn by the LM-7805 IC, the voltage drop across the 3 ohm resistor is .6V, enough to turn on transistor Q2. Transistor Q2 takes over and delivers the current to the output. Note that if the output voltage goes down, the LM-7805 regulator will draw more current, forcing the output voltage back to 5V. Thus, the LM-7805 regulator controls the output voltage and keeps it at 5V.

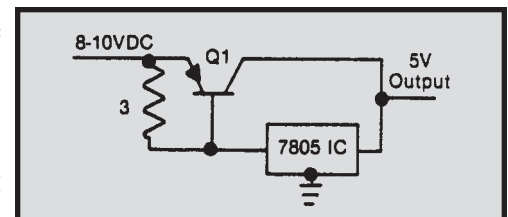

**Figure 7**

Unfortunately, this circuit has no control of the output maximum current. If the output is shorted to ground transistor Q2 will be overloaded and eventually be damaged. The LM-7805 IC will only draw the .2A it was designed to handle and never heat up to turn itself off. Another transistor Q1 is added to limit maximum current. Resistor R5 is added to sense the current in transistor Q2. When approximately 3A is drawn in transistor Q2, the voltage drop in resistor R5 will turn on transistor Q1. This will force more current in the LM-7805 IC. Eventually the LM-7805 IC will overheat turning itself off and thus limiting the circuit at about 3.2A.

The first .2A of current is drawn by the LM-7805 IC. The next 3A are drawn by transistor Q2. Thereafter, the current is drawn by the LM-7805 IC until it overheats and turns itself off. This is a very effective circuit capable of regulating the output voltage at a constant 5 volts and yet delivering over 3A of current.

## QUIZ

1. AC voltage is supplied to the rectifier stages by the
  - A. step up transformer.
  - B. step down transformer.
  - C. 1 to 1 transformer.
  - D. AC to DC transformer.
2. The secondary windings of the transformer are . . .
  - A. 90° out of phase.
  - B. 180° out of phase.
  - C. 270° out of phase.
  - D. 320° out of phase.
3. Diodes allow current to flow . . .
  - A. when the anode is more negative than the cathode.
  - B. when the cathode is more positive than the anode.
  - C. in one direction.
  - D. when a negative or positive voltage is on the anode.
4. What circuit is more efficient for rectifying AC to DC?
  - A. Hartley oscillator.
  - B. Half-wave.
  - C. Schmitt trigger.
  - D. Full-wave.
5. The DC voltage is smoothed by using a . . .
  - A. half-wave rectification circuit.
  - B. small value capacitor with a high voltage value.
  - C. Large value capacitor.
  - D. 90° out of phase rectification circuit.
6. An in efficient rectification circuit usually contains . . .
  - A. large gaps between cycles.
  - B. twice the AC voltage needed.
  - C. more diodes.
  - D. all of the above.
7. The maximum current that a diode can handle is determined by . . .
  - A. the transformer's current rating.
  - B. the amount of AC ripple.
  - C. three times the diode rating.
  - D. peak current rating.
8. The LM317 will shut down when . . .
  - A. the output voltage is too high.
  - B. no current is being drawn.
  - C. the junction overheats.
  - D. the output voltage drops to 1.25V.
9. The LM317 regulator contains . . .
  - A. a pass transistor.
  - B. a constant current source.
  - C. a differential amplifier.
  - D. all of the above.
10. The LM317 is basically . . .
  - A. a 1.25V regulator.
  - B. a 6.25V regulator.
  - C. a 2.5V regulator.
  - D. a negative voltage regulator.

Answers: 1. B, 2. B, 3. C, 4. D, 5. C, 6. D, 7. D, 8. C, 9. A, 10. A

# SPECIFICATIONS ON XP-620 POWER SUPPLY

Input Voltage	110-130VAC
Output Voltage (at 120V input)	1) 1.5-15VDC @ 1A 2) 1.5-15VDC @ 1A 3) 5VDC @ 3A
Output Regulation	200mV each supply
Line Regulation	100mV each supply
Ripple Max	5mV rms
Current Protection	1A limit 2-15VDC 3A limit 5VDC
Short Protection	1A limit 2-15VDC 3A limit 5VDC
Output Impedance	.025Ω each supply

## SCHEMATIC DIAGRAM

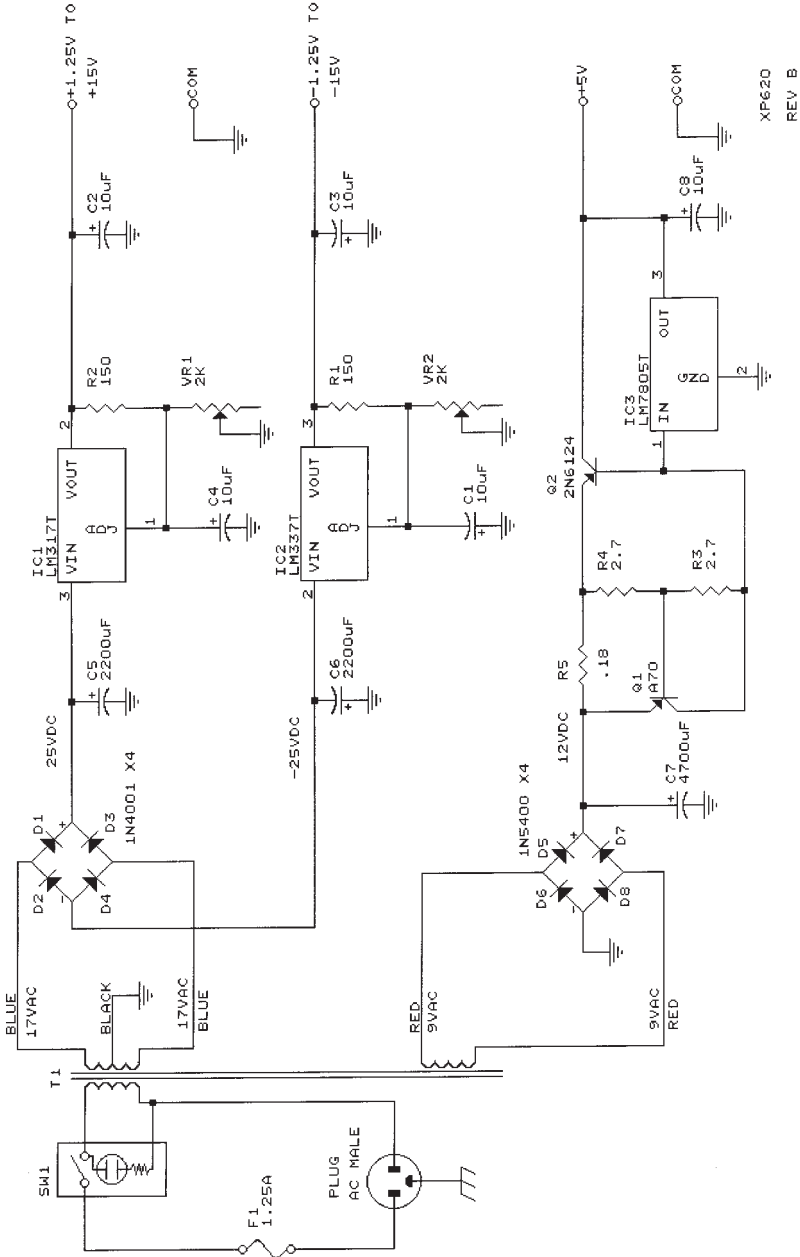

XP620  
REV B

**Elenco™ Electronics, Inc.**

150 W. Carpenter Avenue

Wheeling, IL 60090

(847) 541-3800

<http://www.elenco.com>

e-mail: [elenco@elenco.com](mailto:elenco@elenco.com)