

STOPPER® II SERIES



ADA
Compliant



STI-1100 and
STI-1130 only

INSTALLATION INSTRUCTIONS

Features:

- UL, cUL Listed, 49G2.
- ADA Compliant.
- FM Approved, STI-1100 and STI-1130 only, 0G6A2.AV.
- Can be used as a guard against physical damage to manual pull station, with or without optional warning horn.
- Optional horn has choice of 95 dB or 105 dB at 1 ft.
- Lifetime guarantee against breakage of polycarbonate housing in normal use and one year on electronics.
- With backplate and gaskets, UL Listed to NEMA 3R Standards (IP 14 Rating equivalency).

Photo is a generic representation to reflect the many manufacturers of manual pull stations.



Safety Technology International, Inc.

"We Protect The Things That Protect You."

UL Listed Models Included on this Install Sheet

Indoor Use:

- STI-1100** With horn for flush mounted appliances.
- STI-1100RC** With horn for flush mounted appliances includes relay contacts capable of operating from 9-24 VDC remote power or internal 9V battery power.
- STI-1130** With horn and 2" conduit spacer for surface mounted appliances and electrical boxes.
- STI-1130RC** Surface mounted version of the 1100RC includes 2" conduit spacer.
- STI-1200** Without horn for flush mounted appliances.
- STI-1230** Without horn, with 2" conduit spacer for surface mounted appliances and electrical boxes.

Indoor/Outdoor Use (Weather Stopper Models):

All outdoor units include necessary gaskets.

- STI-1150** With horn for flush mounted appliances.
- STI-1150RC** With horn for flush mounted appliances includes relay contacts capable of operating from 9-24 VDC remote power or internal 9V battery power and includes weather gasket.
- STI-1155** Surface mounted version of the STI-1150 includes 2" conduit spacer.
- STI-1155RC** Surface mounted version of the STI-1150RC includes 2" conduit spacer.
- STI-1250** Without horn for flush mounted appliances.
- STI-3150** Without horn with 2" conduit spacer for surface mounted appliances and electrical boxes.
- STI-1102** Replacement horn for cover with alarm.
- Custom-LBL** Custom text message for horn housing.

Testing Approvals

It has been tested and approved or listed by:

- Underwriter Laboratories No. 49G2
- Factory Mutual No. OG6A2.AY (STI-1100 and STI-1130 only)
- Meets NEMA 3R when mounted to smooth non-masonry surfaces (only for Stopper II models with backplate and gaskets)
- NYC BSA #947-81-5A
- IP 14 Rating (Testing to NEMA 3R standards provides equivalency to an IP rating of 14)
- Obtain local fire marshal approval for State of California
- UL Certified to meet ADA compliance.

PATENTS

- United States No. 4267549, Canada No. 1147828Z

Specifications

Polycarbonate Enclosure

- Flammability UL94 V-2
- Wall Thickness .095 inches
- NEMA Rating Meets NEMA 3R when mounted to smooth non-masonry surfaces

Specifications (continued)

Gaskets

- Closed Cell IV2 with pressure sensitive adhesive
- Replace after 5 years

Horn

	9V	12V	24V
• Low (95 dB @ 1 ft.)	96mA	107mA	125mA
• High (105 dB @ 1 ft.)	130mA	145mA	182mA
• Min. Operating Req.	2V @ 20mA	4V @ 20mA	4V @ 20mA

Relay

	9V	12V	24V
• Relay	23mA	25mA	29mA
• Min. Activation Voltage	3.7V	5.8V	5.8V
• Reset Voltage	1.5V	3.3V	3.3V
• Dry Contact Rating (type Form "C")	<30V, 1A	<30V, 1A	<30V, 1A

Temperature Range

- -40°F (-40°C) to 120°F (49°C)
- For temperatures below -4°F (-20°C) recommend using remote power source

Warranty

- Lifetime on polycarbonate within normal use
- One year on all electronics

Important Notice

Stopper II is intended to be used in areas where the incidence of false fire alarms from manual pull stations is high or has proven to be a serious problem. Any disadvantage of this device is more than balanced when one considers the consequences of false fire alarms, especially if fire service personnel and equipment are responding to a false fire alarm when they are needed for a real fire somewhere else. Add to this the disruption to the facility when false alarms occur. If you have, or may have, a problem with false fire alarms or physical/weather damage to your fire alarm activation devices, the Stopper II could prove invaluable.

Installation Notes

1. When used outdoors, the manual pull station must also be rated for outdoor use.
2. The relay contacts on Model STI-1100RC, STI-1130RC, STI-1150RC and STI-1155RC, UL Listing does not permit connection to fire alarm or a life safety function.
3. According to UL Listing, models powered from an external power source cannot be supplied from the fire alarm panel.
4. When properly installed the operation of this cover will not interfere with the function of your life safety system.
5. A backplate and gaskets must be used to achieve NEMA 3R integrity.
6. Horn must be tested annually for proper operation. Battery replacement is recommended annually dependent on use and battery expiration date.
7. If mounting to an uneven surface STI recommends the use of the STI-1280 backplate to ensure proper sealing. If wire access or screw mounting holes are needed, backplate may be drilled as necessary.

Installation Instructions

1. Separate cover and frame leaving cables attached. Slide power switch, on back of horn housing, to "OFF" position (see Fig. 5). Using frame or optional backplate (recommended with all Weather Stopper models) as a template, mark mounting holes on wall taking into consideration placement of pull station or refer to Fig. 1 for dimensional hole placement from center of clear opening.

NOTE: Be sure cover will not interfere with operation of the pull station when installed.

2. If drilling into masonry or drywall use provided anchors. Drill four 1/4" (6.3mm) holes approximately 1 1/4" deep. If drilling into wood, drill four 5/32" (3.9mm) holes 1 1/4" deep. Do not use anchors if drilling into wood.

NOTE: When gaskets are used, install gasket provided by peeling off backing paper and apply with adhesive facing wall. Align holes in gasket with holes drilled and stick on mounting surface.

3. If using STI-1280 backplate, refer to Fig. 3 and 4 for install instructions depending on your application.

NOTE: When drilling hole in backplate NEMA 3R integrity is compromised.

4. Align frame and put screws through frame holes, into anchors and tighten (if used, through spacer, gaskets and optional backplate). For STI-1200, continue to Step 9.

NOTE: When using STI-3100 spacer, be sure to install conduit knockout (2 provided), any additional ventilation (sub-315 grill and sub-316 louver kit), and gaskets before you tighten to the wall. When using conduit gasket (use STI-3003 with 1/2" conduit and STI-3100 spacer or use STI-3004 with 3/4" rigid conduit and STI-3104 spacer) place gasket around conduit in proper location and tighten frame over spacer. For added protection a bead of silicone may be applied to conduit fitting and between STI-1280 backplate and wall. See Fig. 2. Refer to exploded view of flush and surface mount installation options Fig. 3 and 4.

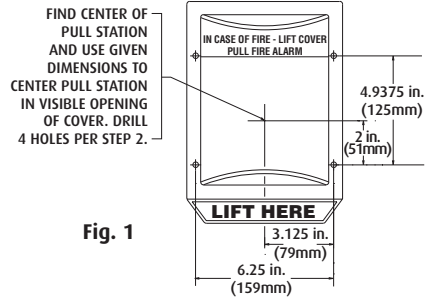

Fig. 1

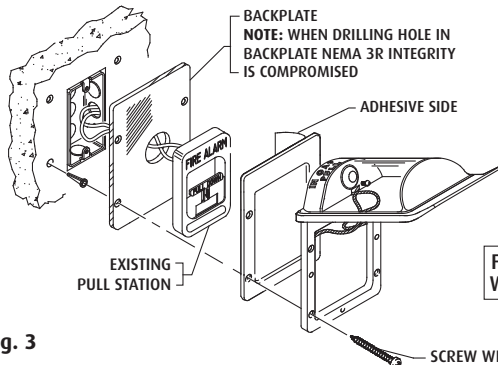

Fig. 3

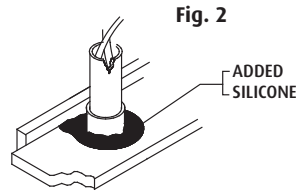

Fig. 2

FLUSH MOUNT WITH OPTIONS

SURFACE MOUNT WITH OPTIONS

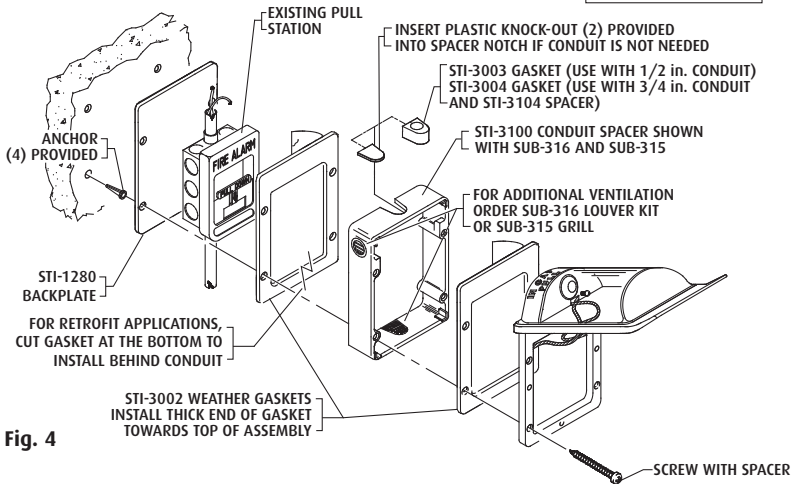

Fig. 4

5. Make any external connections for remote power or relay options. Refer to Fig. 5 for wiring details.
6. Slide power switch, on back of horn housing, to "ON" position (see Fig. 5). When power is connected to unit horn should sound.

NOTE: If external power source is used horn will not sound until power is turned on at source.

7. Push switch in to silence horn while tightening switch locking screw (see Fig. 5 for location of screw). This prevents slide switch from being shutoff during unauthorized use.

CAUTION: Do not tighten when screw is in "OFF" position.

8. Place cover on frame by aligning tabs on cover with slots on frame and push bottom on tightly, horn should silence. To test lift cover, horn should sound, and return cover to frame to silence horn. Unit is armed for operation.

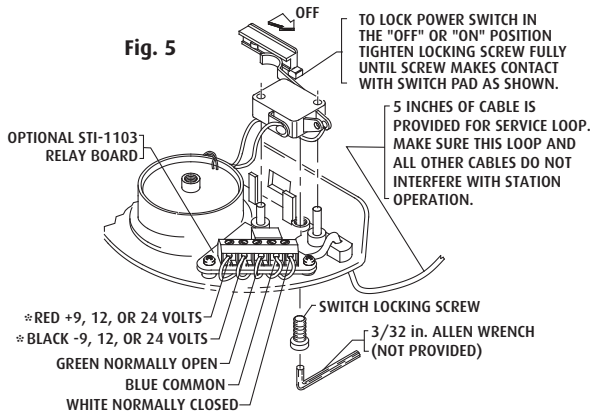

OPTIONAL RELAY CONTACT SETTINGS
STI MODELS 1100RC, 1130RC, 1150RC AND 1155RC
 (**NOT USED WITH 9VDC BATTERY JUMPER)

FACTORY VOLTAGE SETTINGS:
 BATTERY POWERED UNITS: 9 VOLT
 REMOTE POWER "RC" UNITS: 24 VOLT
 NOTE: USE 24 VOLT SETTING FOR USE
 WITH 12 VOLT DC INPUT POWER.

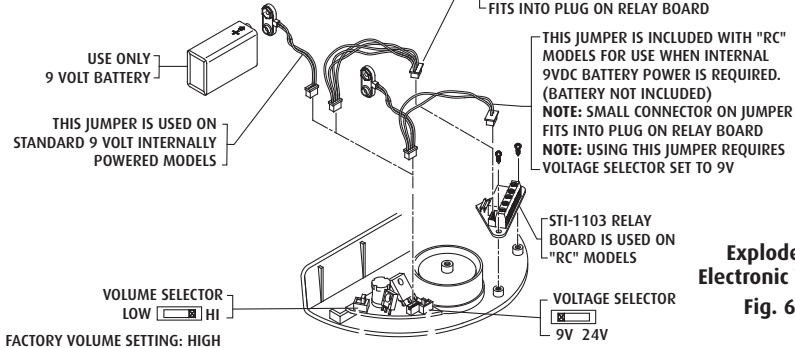

**Exploded
 Electronic View
 Fig. 6**

Gasket Installation

Use of gaskets is necessary to ensure a proper seal in weatherproof applications. Weather Stopper models ship complete with all necessary gaskets and should be used accordingly. For flush mount weather applications, one STI-3002 must be used between the cover and wall or backplate (see Fig. 3). In surface mount applications, one STI-3002 must be placed between the spacer and wall, while another STI-3002 must be placed between the spacer and cover (see Fig. 4). An STI-3003 or STI-3004 gasket must be used around all entering conduit. For surface mount applications, it is also recommended that the SUB-315 grill be installed in the bottom knockout of the conduit spacer. This helps prevent excessive condensation buildup. STI recommends gasket replacement every five years. (UL requires listing of pull station to be UL Listed for outdoor installations).

Battery Replacement Instructions

1. Remove the cover from the frame. It is not necessary to remove the cables from the frame.
2. Use a 3/32" allen wrench to loosen the button head screw located next to the switch far enough to slide the switch to the "off" position.
3. Holding the horn housing and cover in one hand, remove the button head screw located on the top of the cover with the same allen wrench.
4. Set the clear cover aside and remove the horn housing cover.
5. Replace the battery with a 9 Volt battery only. Be careful to keep the wires away from the slide switch and the micro-switch.
6. Reassemble the unit making sure that the horn housing fits into the tabs on the horn housing cover; and that this assembly is mounted evenly into the clear cover.
7. Replace the button head screw through the top of the clear cover and into the top of the horn.
8. Slide the switch to the "on" position. The horn should sound.
9. Push the switch in to silence horn while tightening the "on" position locking screw.
10. Replace the cover onto the frame and test by removing the cover from the frame. The horn should sound when removed and silence when cover is replaced. If unit does not operate correctly, contact Safety Technology International, Inc.

Polycarbonate Cleaning Instructions

Rinse with water to remove abrasive dust and dirt. Wash with soap or mild detergent, using a soft cloth. Rinse once more, then dry with a soft cloth or chamois. Exercise caution when using water inside enclosure. Make sure unit is completely dry inside before reassembling. To remove grease or wet paint from exterior of cover, rub gently with a cloth thoroughly wetted with Naptha. Then wash and rinse. (Do not use razor blades).

Options Available

- STI-1280 Backplate for mounting appliances to uneven surface.
- STI-3002 Weather gaskets
- STI-3100 Large conduit clear 2" conduit spacer for 1/2" conduit
- SUB-315 Grill for Ventilation Kit
- SUB-316 Louvers for extra ventilation
- STI-3003 1/2" conduit gasket
- STI-3004 3/4" rigid conduit gasket
- STI-3104 Modified STI-3100 with larger top conduit opening to accommodate the STI-3004 3/4" rigid conduit gasket.

Product Dimensions

- EXTERNAL DIMENSIONS:**
- FLUSH 7.2 W x 10.2 H x 3.3 D in. (183x259x84mm)
 - SURFACE 7.2 W x 10.2 H x 5.5 D in. (183x259x140mm)

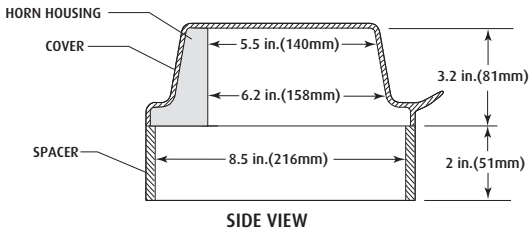

MODELS WITH HORN (STI-1100 Series)

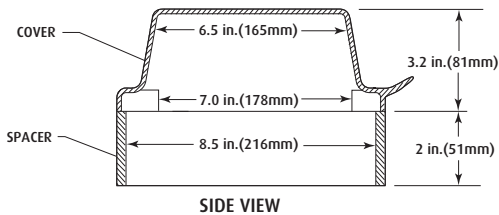

MODELS WITHOUT HORN (STI-1200 AND STI-3150 Series)

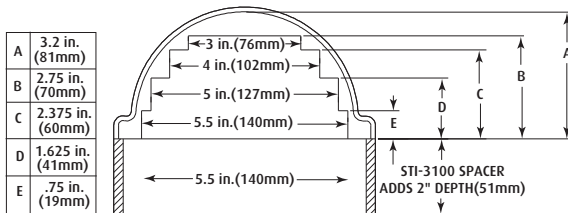

ALL MODELS END VIEW



Safety Technology International, Inc.

2306 Airport Road
Waterford, Michigan 48327-1209
Phone: 248-673-9898 • Toll Free: 800-888-4784 • Fax: 248-673-1246

www.sti-usa.com

Safety Technology International (Europe) Ltd.

Unit 49G Pipers Road • Park Farm Industrial Estate • Redditch
Worcestershire • B98 0HU • England • Tel: 44 (0) 1527 520 999
Fax: 44 (0) 1527 501 999 • Freephone: 0800 085 1678 (UK only)
E-mail: info@sti-europe.com • Web: www.sti-europe.com