

Pressure Sensor series

Pressure Sensor IC

BM1386GLV

General Description

BM1386GLV is piezo-resistive pressure sensor. BM1386GLV performs temperature compensation for MEMS inside chip internally, so it's very easy to get pressure information.

Key Specifications

- Pressure Range: 300hPa to 1300hPa
- Relative Pressure Accuracy: $\pm 0.12\text{hPa(Typ)}$
- Absolute Pressure Accuracy: $\pm 1\text{hPa(Typ)}$
- Operating Temperature Range: -40°C to $+85^{\circ}\text{C}$

Features

- Piezo-resistive pressure sensor
- Pressure range is from 300hPa to 1300hPa
- Built-in temperature compensation function.
- I2C bus interface (f/s mode support)
- Built-in FIFO
- Small package

Applications

- Smartphone, Healthcare, mobile device (e.g. game).

Package

CLGA10V020A

W(Typ) x D(Typ) x H(Max)

2.0mm x 2.0mm x 1.0mm



Typical Application Circuit

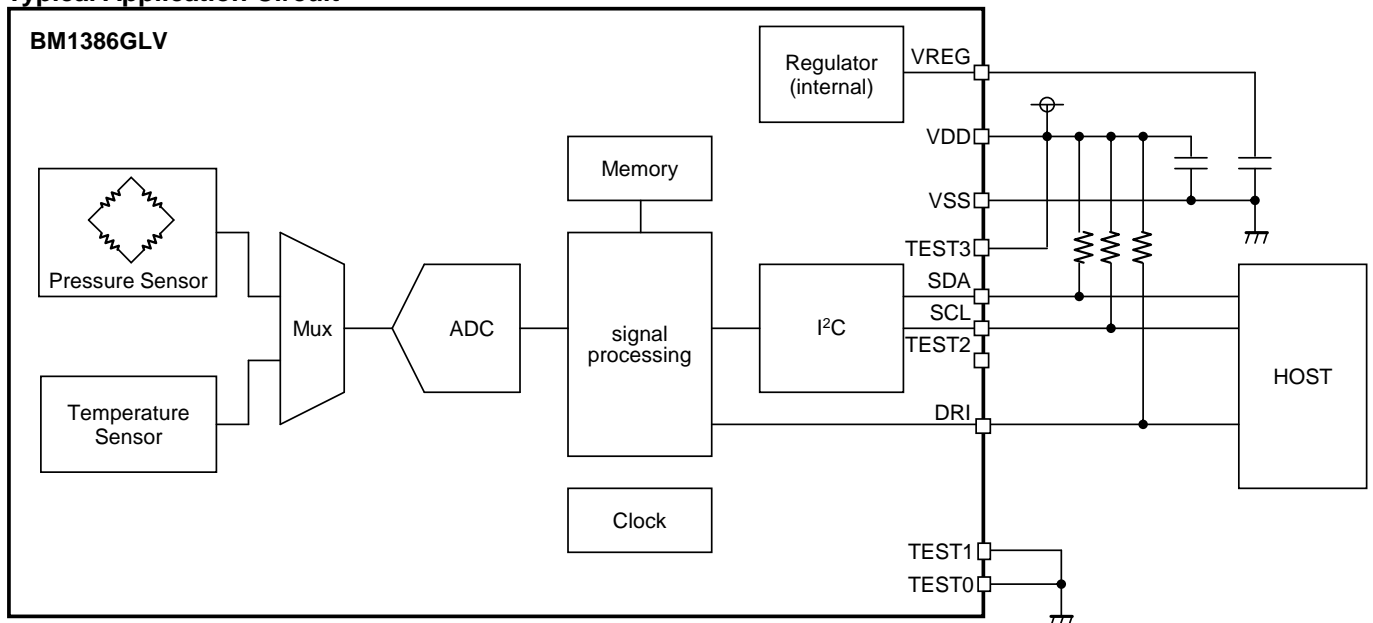

○Product structure : Silicon monolithic integrated circuit ○This product has no designed protection against radioactive rays

Contents

General Description	1
Features.....	1
Applications	1
Key Specifications	1
Package.....	1
Typical Application Circuit.....	1
Pin Configuration	3
Pin Description.....	3
Block Diagram	4
Absolute Maximum Ratings	5
Thermal Resistance.....	5
Recommended Operating Conditions	5
Electrical Characteristics	6
I ² C Bus Timing Characteristics	7
I ² C Bus Communication.....	7
I ² C bus Slave Address.....	8
Register Map	8
FIFO	14
Interrupt function.....	16
Typical Performance Curves.....	17
Control sequence.....	18
Application Example	22
I/O Equivalent Circuits	23
Operational Notes.....	24
Ordering Information.....	26
Marking Diagrams.....	26
Physical Dimension, Tape and Reel Information	27
Revision History.....	28

Pin Configuration

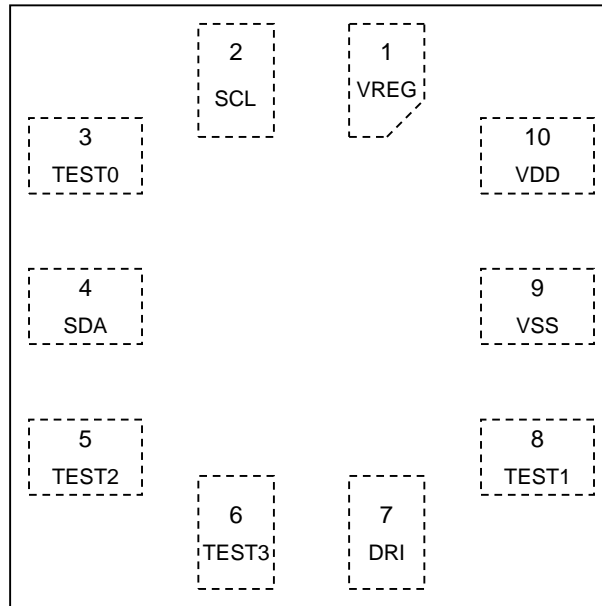
Top View
(pads not visible)

Pin Description

Pin No.	Pin Name	Function
1	VREG	Internal power supply pin ^(Note 1)
2	SCL	I2C serial bus colck pin
3	TEST0	Test pin (connect to VSS)
4	SDA	I2C serial bus data pin
5	TEST2	Test pin (open)
6	TEST3	Test pin (connect to VDD)
7	DRI	Interrupt notice output pin
8	TEST1	Test pin (connect to VSS)
9	VSS	Ground pin
10	VDD	power voltage pin ^(Note 2)

(Note 1) Dispose a bypass capacitor as close as possible to the IC.
Please set a bypass capacitor of 0.22 μ F between DREG and VSS.
Please do not use this pin for external power source.

(Note 2) Dispose a bypass capacitor as close as possible to the IC.

Block Diagram

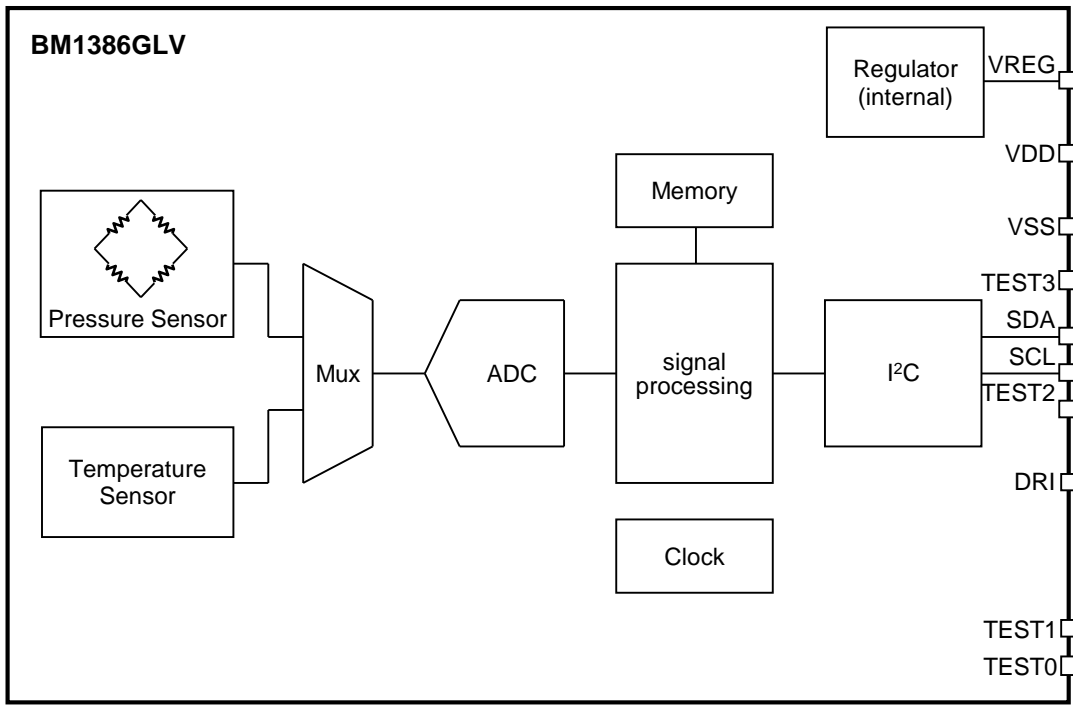

Absolute Maximum Ratings (Ta = 25°C)

Parameter	Symbol	Rating	Unit
Power Supply	V _{DD_MR}	4.5	V
Input Voltage1 ^(Note 1)	V _{IN1MR}	-0.3 to +4.5	V
Input Voltage2 ^(Note 2)	V _{IN2MR}	-0.3 to (V _{DD} +0.3) or +4.5 whichever is less	V
Storage Temperature	T _{stg}	-40 to +125	°C
Maximum Junction Temperature	T _{jmax}	125	°C
Pressure	P _{ovr}	20000	hPa

(Note 1) DRI, SCL, SDA pin

(Note 2) except DRI, SCL, SDA pin

Caution 1: Operating the IC over the absolute maximum ratings may damage the IC. The damage can either be a short circuit between pins or an open circuit between pins and the internal circuitry. Therefore, it is important to consider circuit protection measures, such as adding a fuse, in case the IC is operated over the absolute maximum ratings.

Caution 2: Should by any chance the maximum junction temperature rating be exceeded the rise in temperature of the chip may result in deterioration of the properties of the chip. In case of exceeding this absolute maximum rating, increase the board size and copper area to prevent exceeding the maximum junction temperature rating.

Thermal Resistance^(Note 1)

Parameter	Symbol	Thermal Resistance (Typ)		Unit
		1s ^(Note 3)	2s2p ^(Note 4)	
CLGA10V020A				
Junction to Ambient	θ _{JA}	339.7	217.5	°C/W
Junction to Top Characterization Parameter ^(Note 2)	Ψ _{JT}	154	140	°C/W

(Note 1)Based on JESD51-2A(Still-Air)

(Note 2)The thermal characterization parameter to report the difference between junction temperature and the temperature at the top center of the outside surface of the component package.

(Note 3)Using a PCB board based on JESD51-3.

Layer Number of Measurement Board	Material	Board Size
Single	FR-4	114.3mm x 76.2mm x 1.57mmt
Top		
Copper Pattern	Thickness	
Footprints and Traces	70μm	

(Note 4)Using a PCB board based on JESD51-7.

Layer Number of Measurement Board	Material	Board Size			
4 Layers	FR-4	114.3mm x 76.2mm x 1.6mmt			
Top		2 Internal Layers		Bottom	
Copper Pattern	Thickness	Copper Pattern	Thickness	Copper Pattern	Thickness
Footprints and Traces	70μm	74.2mm x 74.2mm	35μm	74.2mm x 74.2mm	70μm

Recommended Operating Conditions

Parameter	Symbol	Min	Typ	Max	Unit
Power Supply	V _{DD}	1.7	1.8	3.6	V
Input Voltage1 ^(Note 1)	V _{IN1}	0.0	-	3.6	V
I ² C clock Input Frequency	f _{SCL}	-	-	400	kHz
Operating Temperature	T _{opr}	-40	+25	+85	°C

(Note 1) DRI, SCL, SDA pin

Electrical Characteristics (Unless otherwise specified VDD=1.8V Ta=25°C)

Parameter	Symbol	Min	Typ	Max	Unit	Conditions
Current Consumption						
Power Down Mode Current	I _{SS}	-	1	5	μA	PWR_DOWN=0, RSTB=0
Logic						
L Input Voltage ^(Note 1)	V _{IL}	-	-	0.3 * VDD	V	
H Input Voltage ^(Note 1)	V _{IH}	0.7 * VDD	-	-	V	
L Input Current ^(Note 1)	I _{IL}	-10	-	-	μA	V _{IL} = GND
H Input Current ^(Note 1)	I _{IH}	-	-	10	μA	V _{IH} = VDD
L Output Voltage 1 ^(Note 2)	V _{OL1}	-	-	0.2 * VDD	V	I _L = -0.3mA
L Output Voltage 2 ^(Note 3)	V _{OL2}	-	-	0.2 * VDD	V	I _L = -3mA
Pressure characteristics						
Pressure Detection Range	P _R	300	-	1300	hPa	0°C to 65°C
Relative Pressure Accuracy ^(Note 4)	P _{rel}	-	±0.12	-	hPa	950hPa to 1050hPa
Absolute Pressure Accuracy	P _{abs}	-	±1	-	hPa	1000hPa
Temperature Accuracy	T _{abs}	-	±2	-	°C	25°C to 85°C
Measurement Time ^(Note 5)	T _m	-	-	6	msec	AVE_NUM=000

(Note 1) SDA, SCL pin

(Note 2) DRI pin

(Note 3) SDA pin

(Note 4) Target values

(Note 5) Measurement time is changed by average number of measurement data. It is written in Measurement time more detail.

I²C Bus Timing Characteristics (Unless otherwise specified VDD=1.8V, Ta=25°C)

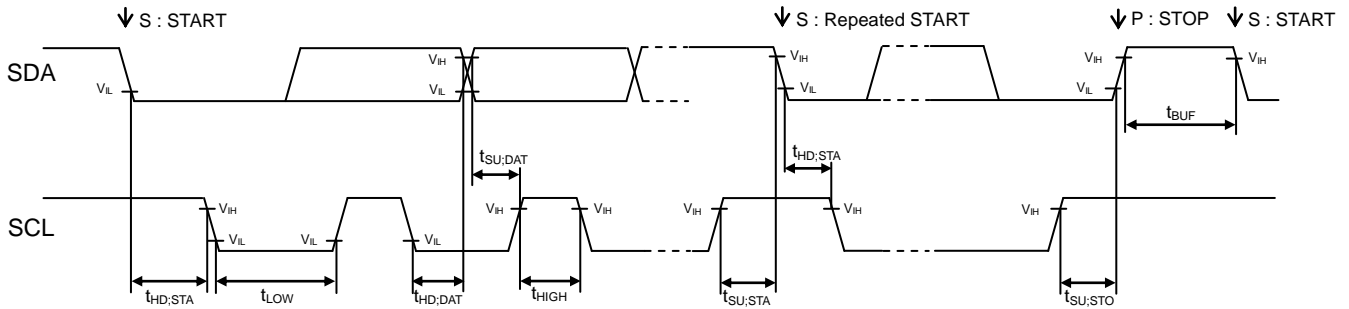

Parameter	Symbol	Min	Typ	Max	Unit	Conditions
SCL Clock frequency	f _{SCL}	0	-	400	kHz	
'L' Period of the SCL Clock	t _{LOW}	1.3	-	-	µs	
'H' Period of the SCL Clock	t _{HIGH}	0.6	-	-	µs	
Setup Time for Repeated START	t _{SU;STA}	0.6	-	-	µs	
Hold Time for START	t _{HD;STA}	0.6	-	-	µs	
Data Setup Time	t _{SU;DAT}	100	-	-	ns	
Data Hold Time	t _{HD;DAT}	0	-	-	µs	
Setup Time for STOP	t _{SU;STO}	0.6	-	-	µs	
Bus Free Time between STOP and START	t _{BUF}	1.3	-	-	µs	

I²C Bus Communication

1. Write Format

(1) Indicate register address



(2) Write data after indicating register address

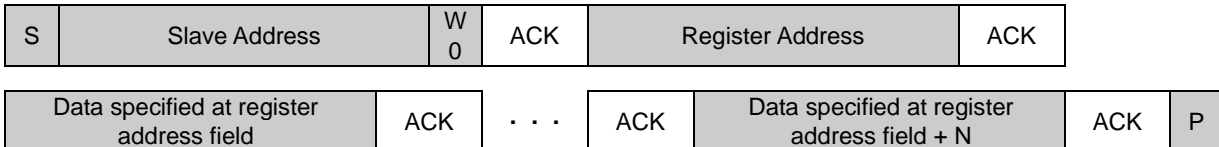

2. Read Format

(1) Read data after indicating register address (Master issues restart condition)

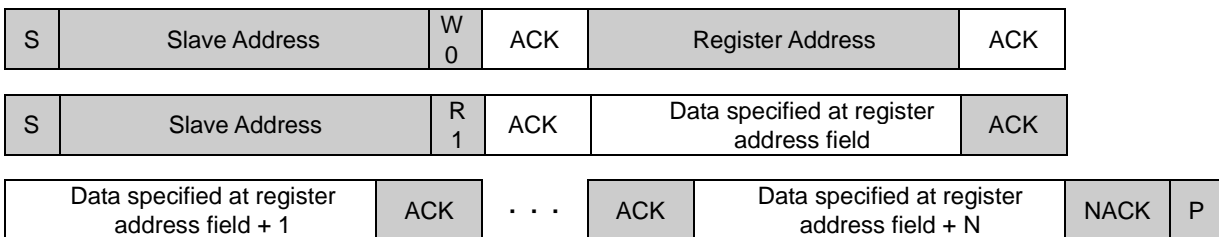

(2) Read data from the specified register

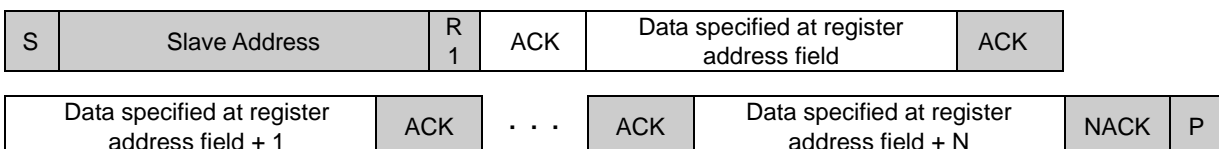

I²C bus Slave Address

The slave address is "1011101".

Register Map (Note 1)

Register Address	Register Name	R/W	D7	D6	D5	D4	D3	D2	D1	D0	
0x0F	MANUFACTURER ID	R	MANUFACTURER ID [7:0]								
0x10	PART ID	R	PART ID [7:0]								
0x12	POWER_DOWN	RW	0	0	0	0	0	0	0	PWR_DOWN	
0x13	RESET	RW	0	0	0	0	0	0	0	RSTB	
0x14	MODE_CONTROL	RW	AVE_NUM[2:0]			DR_EN	FULL_EN	WTM_EN	MODE[1:0]		
0x15	IIR, FIFO CONTROL	RW	FIFO_EN	WTM_LEVEL	0	0	0	0	IIR_MODE[1:0]		
0x18	FIFO data	R	0	0	FIFO_LEV[5:0]						
0x19	STATUS	R	0	0	0	0	0	RD_FULL	RD_WTM	RD_DRDY	
0x1A	PRESSURE	R	PRESS_OUT[15:8]								
0x1B		R	PRESS_OUT[7:0]								
0x1C		R	PRESS_OUT_XL[5:0]						0	0	
0x1D	TEMPERATURE	R	TEMP_OUT[15:8]								
0x1E		R	TEMP_OUT[7:0]								

(Note 1) Do not write any commands to other addresses except above. Do not write '1' to the fields in which value is '0' in above table.
Address from 0x14 to 0x1E registers can be accessed only when PWR_DOWN=1 and RSTB=1. (In other case Write: Ignored, Read: 0xFF)

(0x0F) MANUFACTURER ID

Fields	Function
MANUFACTURER ID [7:0]	Manufacturer ID : 0xE0

(0x10) PART ID

Fields	Function
PART ID [7:0]	Part ID : 0x33

(0x12) POWER_DOWN

Fields	Function
PWR_DOWN	0: power down 1: active

default value 0x00

(0x13) RESET

Fields	Function
RSTB	0: Measurement control block is reset 1: Measurement control block is active

default value 0x00

(0x14) MODE_CONTROL

Fields	Function
AVE_NUM[2:0]	Setting of the averaging number of measurement data 000: single, 001: 2 times, 010: 4 times, 011: 8 times, 100: 16 times, 101: 32 times, 110: 64 times, 111: Prohibited
DR_EN	DRI pin Enable for Data Ready Details are written in Interrupt. 0 : DRI pin Disable, 1 : DRI pin Enable
FULL_EN	DRI pin Enable for FULL Details are written in Interrupt more detail. 0 : DRI pin Disable, 1 : DRI pin Enable
WTM_EN	DRI pin Enable for Water Mark Details are written in Interrupt. 0 : DRI pin Disable, 1 : DRI pin Enable
MODE[1:0]	Measurement mode setting (Pressure and Temperature are measured at one rate) 00 : Stand by, 01 : One shot, 10 : Continuous, 11 : Prohibited

default value 0x00

Measurement time and RMS noise against number of average

AVE_NUM	Measurement time T_m max[ms]	Measurement cycle T_i max[ms]	RMS noise [hPa]
000	6	60	0.090
001	9	60	0.063
010	16	60	0.045
011	30	60	0.032
100	60	60	0.023
101	120	120	0.016
110	240	240	0.011

RMS noise is calculated as standard deviation of 32 data points (1σ).
RMS noise is a reference value and it's not the value with guarantee.
Condition VDD=1.8V, Ta=25°C, IIR_MODE=00

Measurement time

One shot mode perform one measurement. Measurement data is updated when measurement completed, so it should be read more than T_m after measurement start.
Continuous mode repeat measurement in every measurement cycle T_i . The latest measurement data which is completed is read.
Measurement time T_m and measurement cycle T_i is determined by number of average.

<One shot mode>

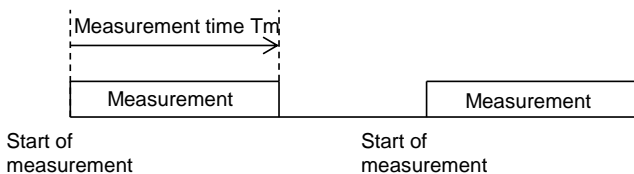

<Continuous mode>

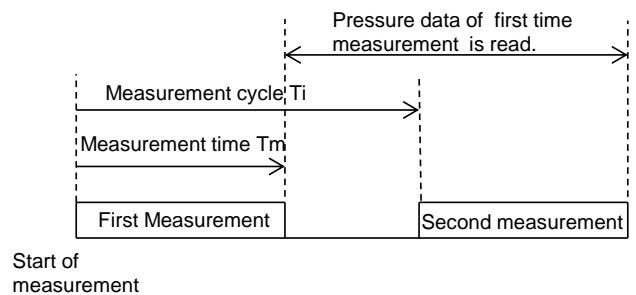

Operation mode transition

Please refer to the below figure of operation mode transition.

Power down mode is the smallest current consumption mode due to circuit is OFF. Please set this mode when reducing current consumption. Measurement is not available in this mode, so the measurement is performed after switching to standby mode.

In reset mode, regulator for internal blocks is active and measurement control block is reset. Register is initialized in Reset mode. Measurement command is acceptable when "1" is written in "RSTB"

There are 2 measurement modes. One shot mode and Continuous mode. They are transferred from stand by mode. Then, please set "AVE_NUM" register at the same time. Please write "0x1400" when transferring to standby mode again.

In one shot mode, a single measurement is performed when "01" is written in "MODE". After the measurement completes, it is transferred to standby mode automatically. When "0x1400" is written before end of measurement, mode is switched to standby immediately but pressure value is not updated. Transition to the other measurement mode during measurement in one shot mode is forbidden.

In Continuous mode, when "10" is written in "MODE", measurement starts and it continues until "0x1400" is written. Transition to the other measurement mode from Continuous mode is forbidden.

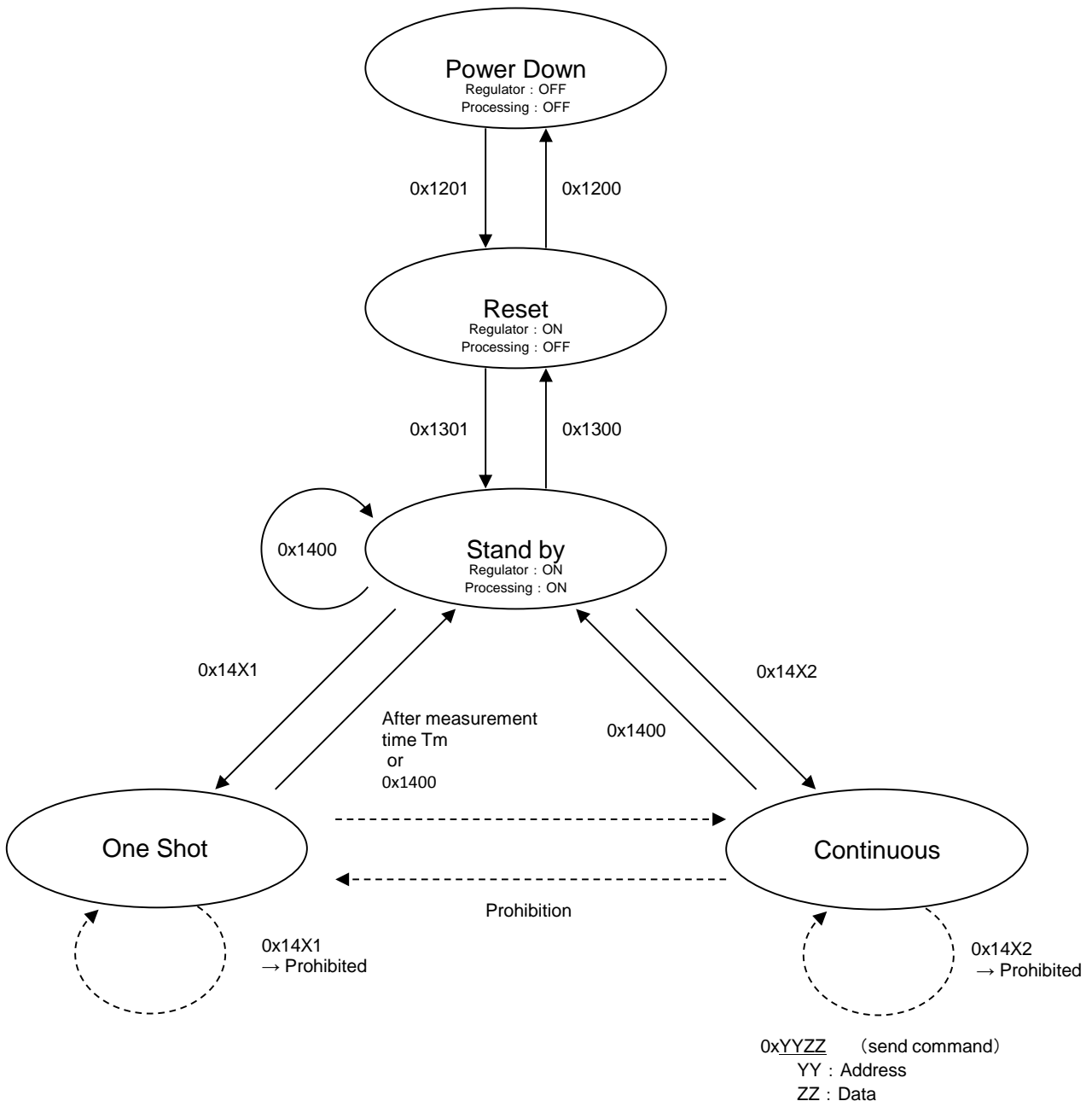

(0x15) IIR, FIFO CONTROL

Fields	Function
FIFO_EN	FIFO mode setting Details are written in FIFO. 0: Bypass mode, 1: FIFO mode
WTM_LEVEL	Water Mark level setting Details are written in FIFO. 0: Water Mark interrupt occur when FIFO memory is 24 or above. 1: Water Mark interrupt occur when FIFO memory is 28 or above.
IIR_MODE[1:0]	IIR filter enable and coefficient setting 00 : IIR OFF, 01 : IIR ON (weak) 10 : IIR ON (middle), 11 : IIR ON (strong)

default value 0x00

(0x18) FIFO data

Fields	Function
FIFO_LEV[5:0]	Number of sample in FIFO

default value 0x00

FIFO_LEV[5:0]

D5	D4	D3	D2	D1	D0	Description
0	0	0	0	0	0	FIFO empty
0	0	0	0	0	1	Number of sample in FIFO =1
:	:	:	:	:	:	
1	0	0	0	0	0	FIFO FULL

(0x19) STATUS

Fields	Function
RD_FULL	FIFO overrun (FULL) status This register is cleared when this is read. RD_FULL is not updated unless data are read. 0: FIFO is not full; 1: FIFO is full.
RD_WTM	FIFO threshold (Water Mark) status This register is cleared when FIFO memory become less than threshold level. 0: Number of sample in FIFO is lower than threshold level. 1: Number of sample in FIFO is equal or higher than threshold level.
RD_DRDY	Pressure and temperature measurement data ready bit This register is cleared when '1' is read. Do not care RD_DRDY in FIFO mode (FIFO_EN=1). 0: data is not updated 1: data is updated

default value 0x00

(0x1A / 0x1B / 0x1C) PRESSURE

Fields	Function
PRESS_OUT[15:0] PRESS_OUT_XL[5:0]	pressure data

default value 0x000000

Conversion to pressure value is below.

Pressure counts = PRESS_OUT[15:8] x 2¹⁴ + PRESS_OUT[7:0] x 2⁶ + PRESS_OUT_XL[5:0] [counts] (dec)

Pressure value [hPa] = Pressure counts [counts] / 2048 [counts/hPa]

Data registers (0x1A, 0x1B, 0x1C) should be read by burst read.

Data is updated at the timing of measurement completion.

If they are not read by burst read, data might be mixed up with the data of different measurement.

(0x1D / 0x1E) TEMPERATURE

Fields	Function
TEMP_OUT[15:0]	temperature data

default value 0x0000

Conversion to temperature value is below. Please note that TEMP_OUT is data with sign (two's complement).

Temp counts = TEMP_OUT[15:8] x 2⁸ + TEMP_OUT[7:0] [counts] (dec)

Temperature value [°C] = Temp counts [counts] / 32 [counts/°C]
(in case of positive number)

Data registers (0x1D,0x1E) should be read by burst read.

Data is updated at the timing of measurement completion.

If they are not read by burst read, data might be mixed up with the data of different measurement.

FIFO

This IC embeds a 32-slot FIFO to store the pressure and temperature output values.

FIFO has Bypass mode (FIFO_EN=0) and FIFO mode (FIFO_EN=1).

In FIFO mode, the pressure and temperature output values are stored in FIFO when measurement is completed.

The data is read from oldest data.

Interrupt for WTM and FULL is available in FIFO mode.

WTM interrupt is enable when WTM_EN is set to '1'. In this mode, when FIFO memory reach the number set in WTM_LEVEL, RD_WTM goes to '1'.

FULL interrupt is enable when FULL_EN is set to '1'. In this mode, when 32 data are stored in FIFO, RD_FULL goes to '1'.

FIFO_LEV is the number of sample in FIFO.

FIFO is only available in Continuous mode.

<Bypass mode>

FIFO is not operational in Bypass mode (FIFO_EN=0).

New data is overwritten to old data due to only the first slot of FIFO is in use.

FIFO and FIFO_LEV are initialized in Bypass mode.

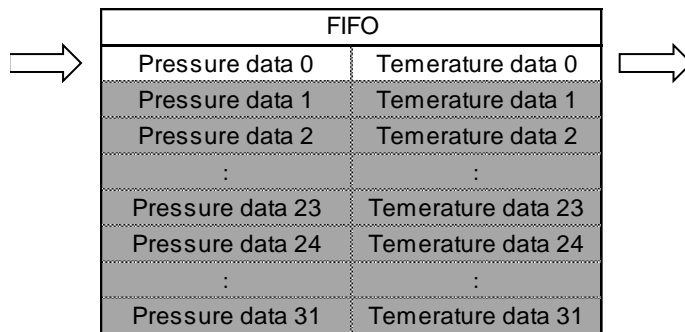

<FIFO mode>

FIFO is operational in FIFO mode (FIFO_EN=1). Pressure data is read from the address 0x1A, 0x1B and 0x1C and temperature data is read from the address 0x1D and 0x1E.

The data is read from oldest data. FIFO stops storing data when FIFO is FULL.

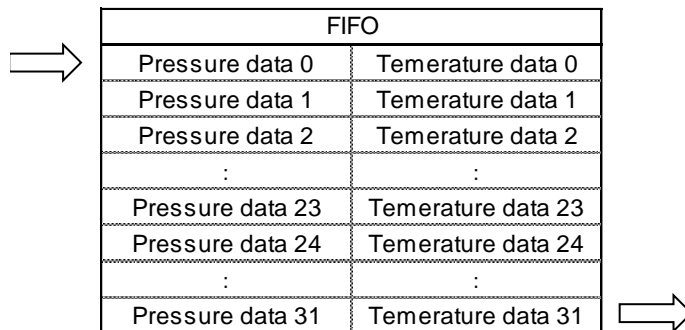

Water Mark interrupt

Water Mark interrupt occur when stored data in FIFO is equal to or the number set in WTM_LEVEL.

Water Mark level is selectable from 24 (WTM_LEVEL=0) and 28 (WTM_LEVEL=1).

RD_WTM goes to '1' when Water Mark interrupt occur

Water ark interrupt keep active state during FIFO_LEV is equal to or more than WTM_LEVEL. And it is released, when FIFO_LEV go below WTM_LEVEL.

DRI pin status is determined by Water Mark interrupt, when WTM_EN is '1'.

Case of Water Mark occurs at 24 of Water Mark level

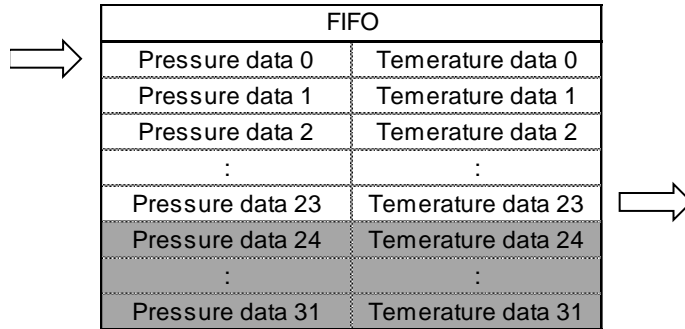

FULL interrupt

FULL interrupt occur when stored data in FIFO is 32. RD_FULL goes '1'.

RD_FULL goes '0' when RD_FULL is read.

FIFO and RD_FULL are not updated by measurement after FULL interrupt occur. Then FIFO_LEV is fixed to 32.

DRI pin status is determined by FULL interrupt, when FULL_EN is '1'.

Case of FULL occurs

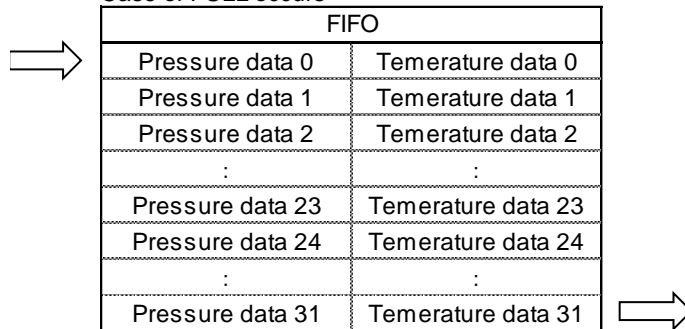

Interrupt function

Interrupt factor is Data Ready, FIFO FULL and FIFO WTM.

The condition is listed below.

The status register is always operational.

The status register goes '1' when interrupt occur.

When the DRI pin enable for each factor is '1', DRI pin status is determined by the interrupt state of factor. When interrupt occur, DRI pin output 'L'.

The status register and DRI pin keeps the state until the interrupt is cleared.

FIFO FULL and FIFO WTM are not available in Bypass mode (FIFO_EN=0)

Do not care Data Ready in FIFO mode (FIFO_EN=1).

Interrupt factor

Factor	Status register	Interrupt condition	Interrupt Clear condition
Data Ready	RD_DRDY	Measurement completion	Read RD_RDRY
FIFO FULL	RD_FULL	FIFO is Full	Read RD_FULL
FIFO WTM	RD_WTM	FIFO_LEV ≥ WTM level	FIFO_LEV < WTM level

Relation between factor and DRI pin enable

Factor	DRI pin enable
Data Ready	DR_EN
FIFO FULL	FULL_EN
FIFO WTM	WTM_EN

DRI pin is Nch open drain so this terminal should be pull-up to voltage source by an external resistor.

DRI pin is high impedance just after VDD is supplied.

DRI pin becomes inactive (High impedance) by reading RD_DRDY register or setting reset mode.

VDD current (approximately 6µA at VDD=1.8V) is consumed during DRI is active.

When disabling interrupt function, please set DREN=0 after clearing interrupt.

<Example of Data Ready interrupt : 1shot mode>

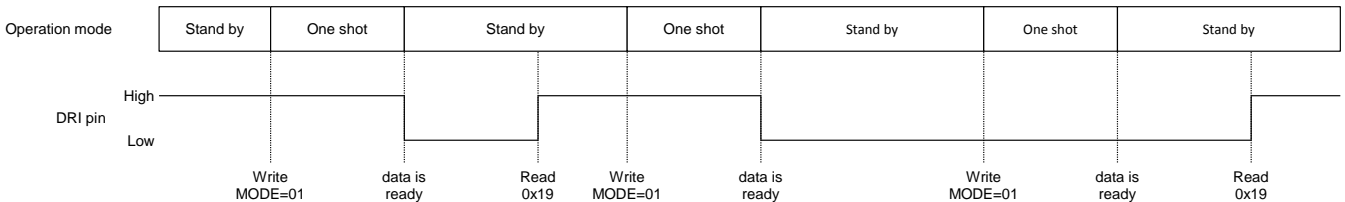

Typical Performance Curves

(Reference data)
 (Unless otherwise specified VDD=1.8V Ta=25°C)

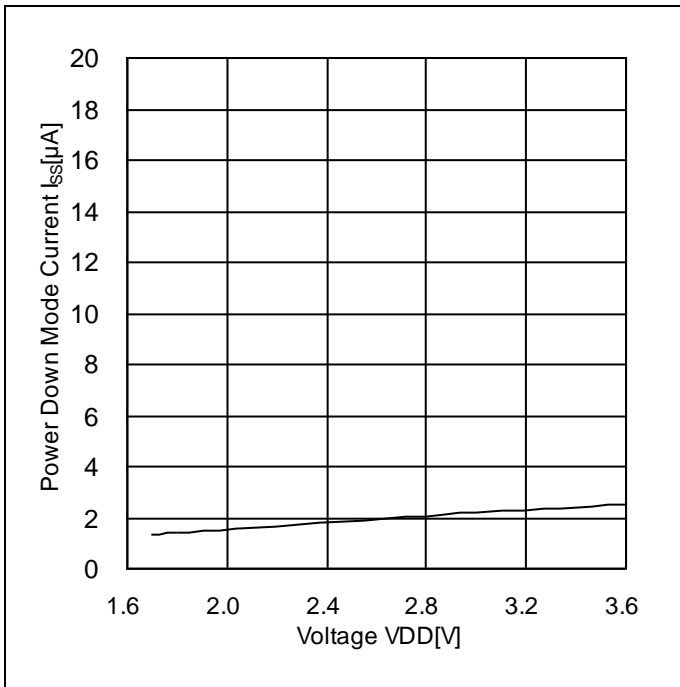

Figure 1. Current vs VDD
 (PWR_DOWN=0, RSTB=0)

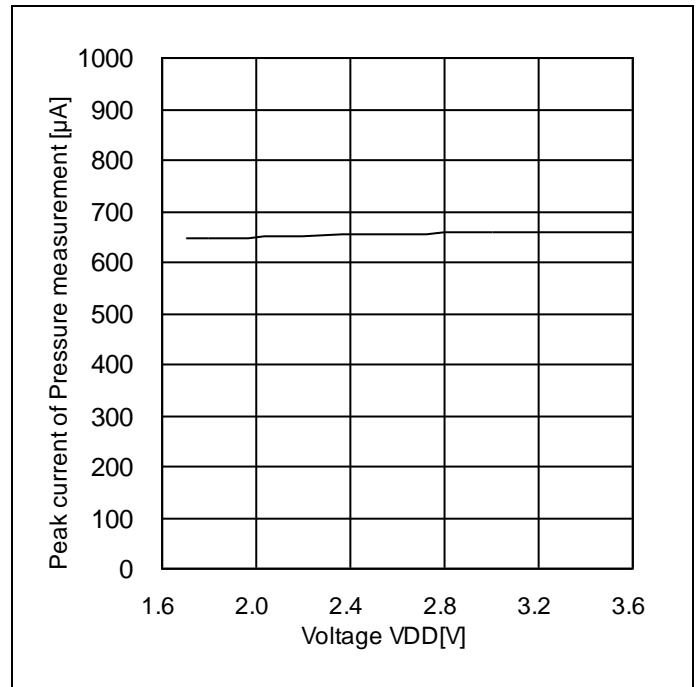
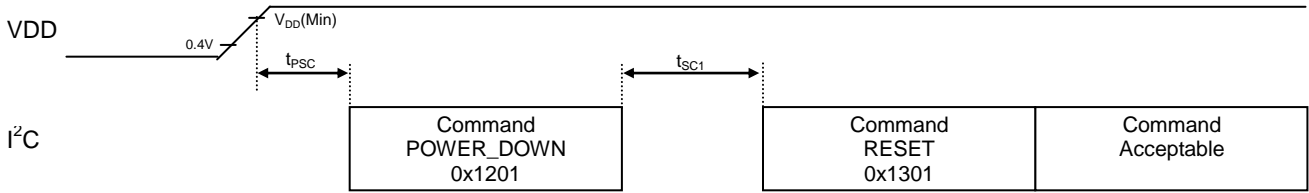

Figure 2. Current vs VDD
 (During measurement)

Control sequence

1. Power-on sequence



Parameter	Symbol	Min	Typ	Max	Unit	Conditions
Command input time after power-on	t _{PSC}	100	-	-	μs	
Reset cancel wait time	t _{SC1}	1	-	-	ms	VREG:0.22μF

t_{PSC} after VDD power-on, command can be input.

Please send reset cancel command (RSTB=1) more than t_{SC1} after regulator for internal blocks become active (PWR_DOWN=1)

2. Power-off sequence

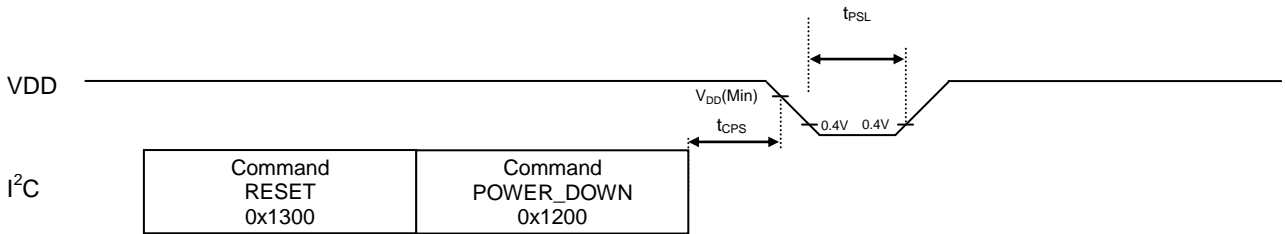

Parameter	Symbol	Min	Typ	Max	Unit	Conditions
Wait time from power down command	t _{CPS}	0	-	-	μs	
Power supply OFF time	t _{PSL}	1	-	-	ms	

Please send reset command (RSTB=0) to turn regulator for internal blocks off (PWR_DOWN=0) t_{CPS} before the VDD power-off.

Please keep VDD Low (VDD<0.4V) more than t_{PSL} before VDD power-on

3. Starting sequence

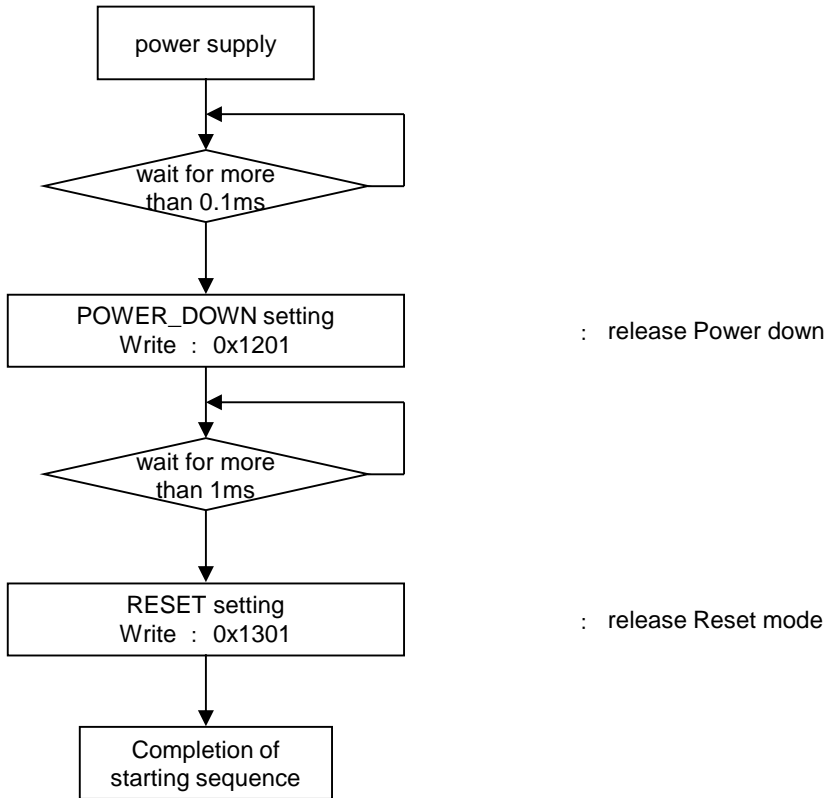

4. Measurement sequence: One Shot Mode

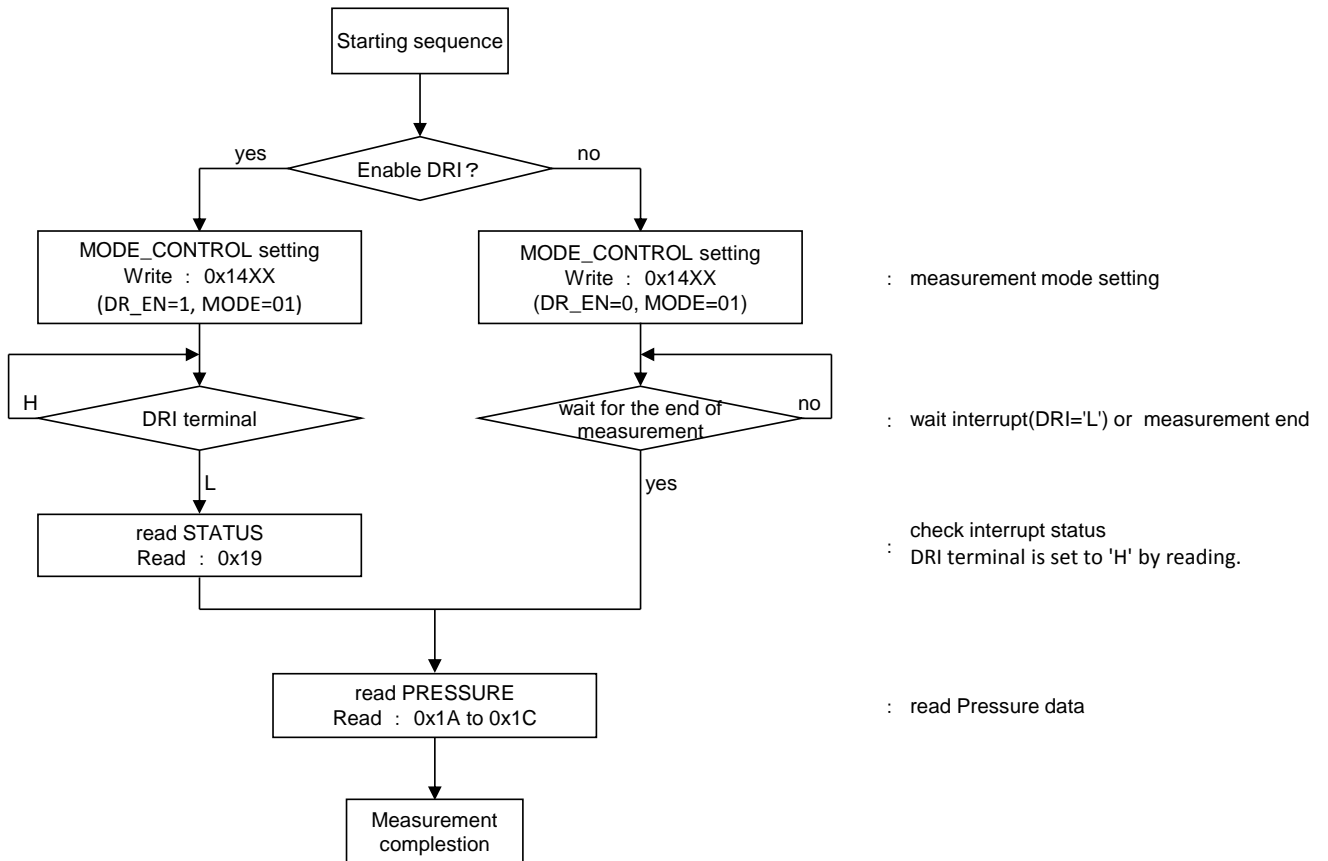

5. Measurement sequence: Continuous Mode

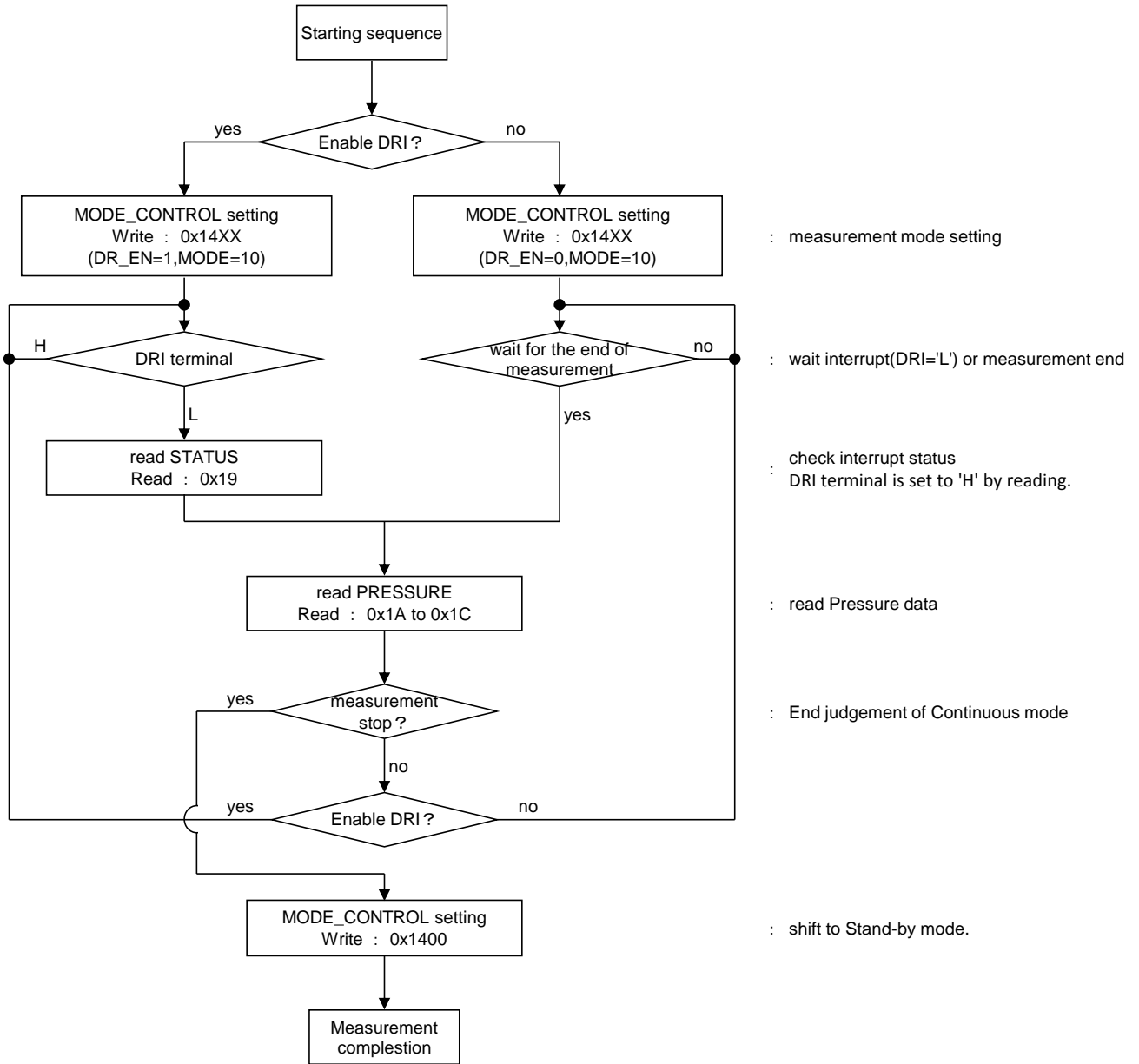

6. Ending sequence

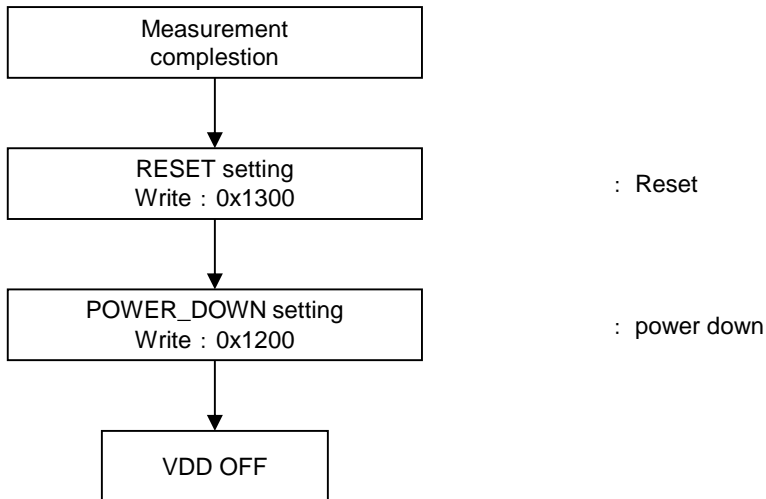

Application Example

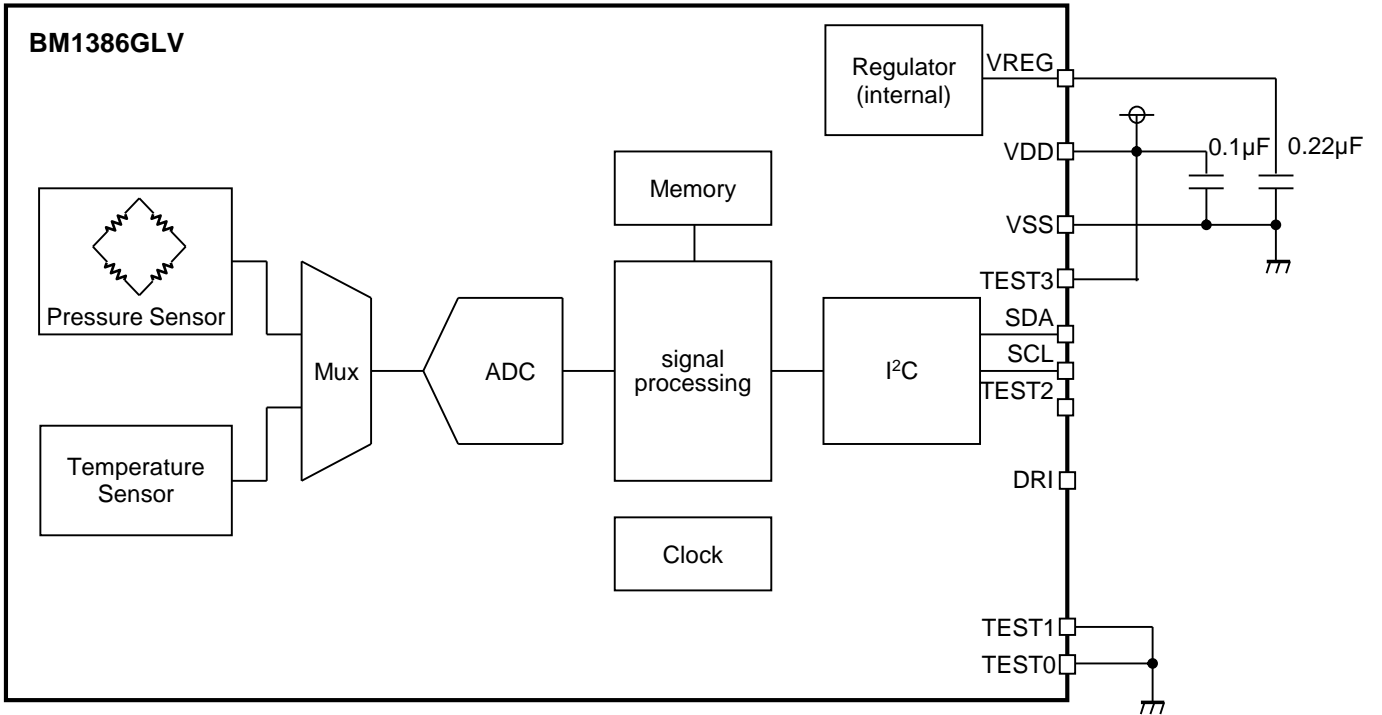

I/O Equivalent Circuits

Pin Name	Equivalent Circuit	Pin Name	Equivalent Circuit
SCL		SDA	
TEST3		VREG	
TEST2		TEST0 TEST1	
DRI			

Operational Notes

1. Reverse Connection of Power Supply

Connecting the power supply in reverse polarity can damage the IC. Take precautions against reverse polarity when connecting the power supply, such as mounting an external diode between the power supply and the IC's power supply pins.

2. Power Supply Lines

Design the PCB layout pattern to provide low impedance supply lines. Furthermore, connect a capacitor to ground at all power supply pins. Consider the effect of temperature and aging on the capacitance value when using electrolytic capacitors.

3. Ground Voltage

Ensure that no pins are at a voltage below that of the ground pin at any time, even during transient condition.

4. Ground Wiring Pattern

When using both small-signal and large-current ground traces, the two ground traces should be routed separately but connected to a single ground at the reference point of the application board to avoid fluctuations in the small-signal ground caused by large currents. Also ensure that the ground traces of external components do not cause variations on the ground voltage. The ground lines must be as short and thick as possible to reduce line impedance.

5. Recommended Operating Conditions

The function and operation of the IC are guaranteed within the range specified by the recommended operating conditions. The characteristic values are guaranteed only under the conditions of each item specified by the electrical characteristics.

6. Inrush Current

When power is first supplied to the IC, it is possible that the internal logic may be unstable and inrush current may flow instantaneously due to the internal powering sequence and delays, especially if the IC has more than one power supply. Therefore, give special consideration to power coupling capacitance, power wiring, width of ground wiring, and routing of connections.

7. Operation Under Strong Electromagnetic Field

Operating the IC in the presence of a strong electromagnetic field may cause the IC to malfunction.

8. Testing on Application Boards

When testing the IC on an application board, connecting a capacitor directly to a low-impedance output pin may subject the IC to stress. Always discharge capacitors completely after each process or step. The IC's power supply should always be turned off completely before connecting or removing it from the test setup during the inspection process. To prevent damage from static discharge, ground the IC during assembly and use similar precautions during transport and storage.

9. Inter-pin Short and Mounting Errors

Ensure that the direction and position are correct when mounting the IC on the PCB. Incorrect mounting may result in damaging the IC. Avoid nearby pins being shorted to each other especially to ground, power supply and output pin. Inter-pin shorts could be due to many reasons such as metal particles, water droplets (in very humid environment) and unintentional solder bridge deposited in between pins during assembly to name a few.

10. Unused Input Pins

Input pins of an IC are often connected to the gate of a MOS transistor. The gate has extremely high impedance and extremely low capacitance. If left unconnected, the electric field from the outside can easily charge it. The small charge acquired in this way is enough to produce a significant effect on the conduction through the transistor and cause unexpected operation of the IC. So unless otherwise specified, unused input pins should be connected to the power supply or ground line.

Operational Notes – continued**11. Regarding the Input Pin of the IC**

In the construction of this IC, P-N junctions are inevitably formed creating parasitic diodes or transistors. The operation of these parasitic elements can result in mutual interference among circuits, operational faults, or physical damage. Therefore, conditions which cause these parasitic elements to operate, such as applying a voltage to an input pin lower than the ground voltage should be avoided. Furthermore, do not apply a voltage to the input pins when no power supply voltage is applied to the IC. Even if the power supply voltage is applied, make sure that the input pins have voltages within the values specified in the electrical characteristics of this IC.

12. Ceramic Capacitor

When using a ceramic capacitor, determine the dielectric constant considering the change of capacitance with temperature and the decrease in nominal capacitance due to DC bias and others.

13. Disturbance light

In a device where a portion of silicon is exposed to light such as in a WL-CSP, IC characteristics may be affected due to photoelectric effect. For this reason, it is recommended to come up with countermeasures that will prevent the chip from being exposed to light.

Ordering Information

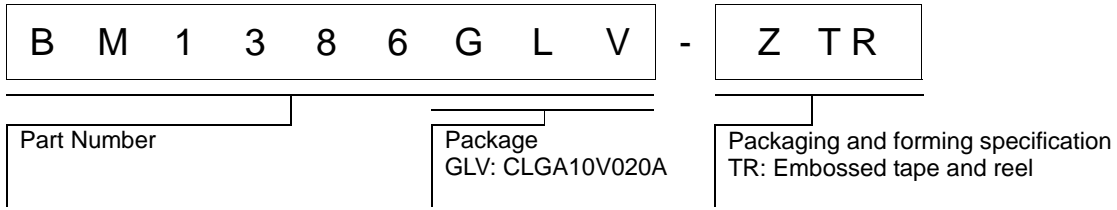

Marking Diagrams

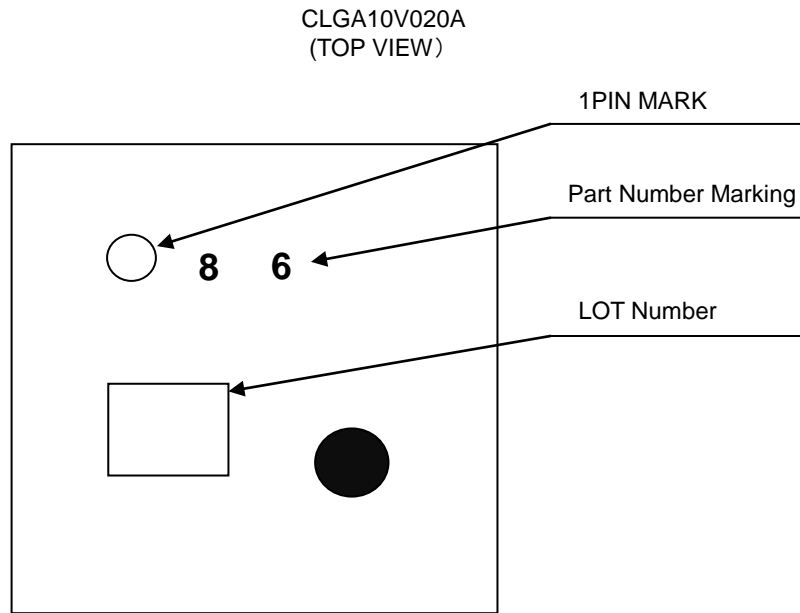

Physical Dimension, Tape and Reel Information

Package Name	CLGA10V020A
--------------	-------------

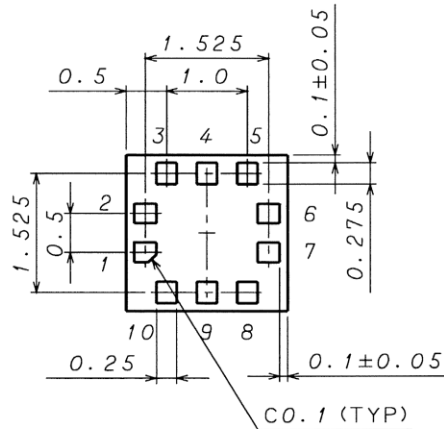
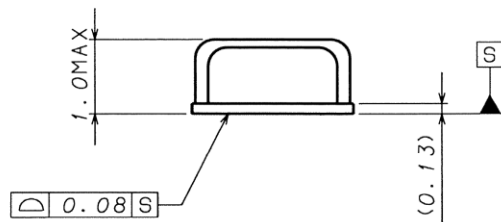
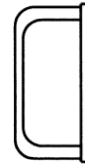
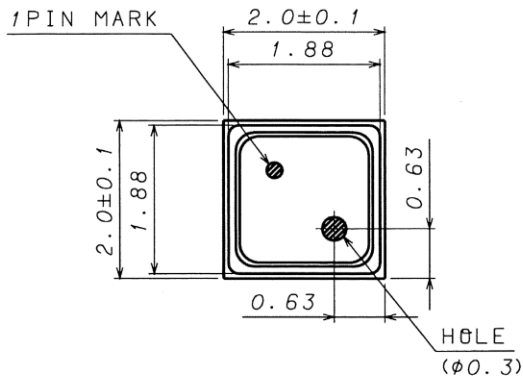

(UNIT: mm)

PKG: CLGA10V020A
Drawing No. EX001-0070-1

<Tape and Reel information>

Tape	Embossed carrier tape
Quantity	3000pcs
Direction of feed	TR (The direction is the 1pin of product is at the upper right when you hold reel on the left hand and you pull out the tape on the right hand)

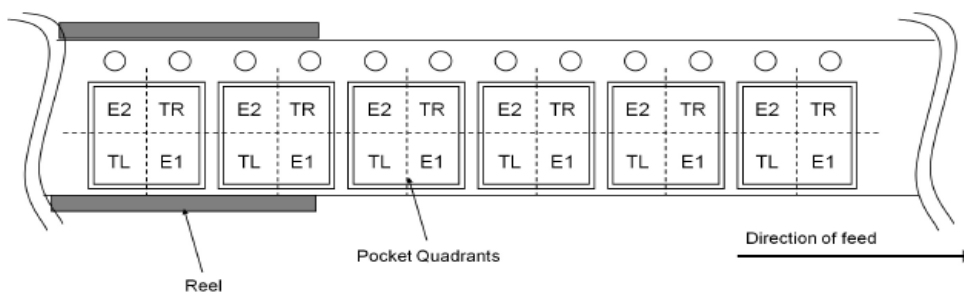

Revision History

Date	Revision	Changes
18.Aug.2017	001	New Release

Notice

Precaution on using ROHM Products

- Our Products are designed and manufactured for application in ordinary electronic equipments (such as AV equipment, OA equipment, telecommunication equipment, home electronic appliances, amusement equipment, etc.). If you intend to use our Products in devices requiring extremely high reliability (such as medical equipment ^(Note 1), transport equipment, traffic equipment, aircraft/spacecraft, nuclear power controllers, fuel controllers, car equipment including car accessories, safety devices, etc.) and whose malfunction or failure may cause loss of human life, bodily injury or serious damage to property ("Specific Applications"), please consult with the ROHM sales representative in advance. Unless otherwise agreed in writing by ROHM in advance, ROHM shall not be in any way responsible or liable for any damages, expenses or losses incurred by you or third parties arising from the use of any ROHM's Products for Specific Applications.

(Note1) Medical Equipment Classification of the Specific Applications

JAPAN	USA	EU	CHINA
CLASS III	CLASS III	CLASS II b	CLASS III
CLASS IV		CLASS III	

- ROHM designs and manufactures its Products subject to strict quality control system. However, semiconductor products can fail or malfunction at a certain rate. Please be sure to implement, at your own responsibilities, adequate safety measures including but not limited to fail-safe design against the physical injury, damage to any property, which a failure or malfunction of our Products may cause. The following are examples of safety measures:
 - Installation of protection circuits or other protective devices to improve system safety
 - Installation of redundant circuits to reduce the impact of single or multiple circuit failure
- Our Products are designed and manufactured for use under standard conditions and not under any special or extraordinary environments or conditions, as exemplified below. Accordingly, ROHM shall not be in any way responsible or liable for any damages, expenses or losses arising from the use of any ROHM's Products under any special or extraordinary environments or conditions. If you intend to use our Products under any special or extraordinary environments or conditions (as exemplified below), your independent verification and confirmation of product performance, reliability, etc. prior to use, must be necessary:
 - Use of our Products in any types of liquid, including water, oils, chemicals, and organic solvents
 - Use of our Products outdoors or in places where the Products are exposed to direct sunlight or dust
 - Use of our Products in places where the Products are exposed to sea wind or corrosive gases, including Cl₂, H₂S, NH₃, SO₂, and NO₂
 - Use of our Products in places where the Products are exposed to static electricity or electromagnetic waves
 - Use of our Products in proximity to heat-producing components, plastic cords, or other flammable items
 - Sealing or coating our Products with resin or other coating materials
 - Use of our Products without cleaning residue of flux (even if you use no-clean type fluxes, cleaning residue of flux is recommended); or Washing our Products by using water or water-soluble cleaning agents for cleaning residue after soldering
 - Use of the Products in places subject to dew condensation
- The Products are not subject to radiation-proof design.
- Please verify and confirm characteristics of the final or mounted products in using the Products.
- In particular, if a transient load (a large amount of load applied in a short period of time, such as pulse. is applied, confirmation of performance characteristics after on-board mounting is strongly recommended. Avoid applying power exceeding normal rated power; exceeding the power rating under steady-state loading condition may negatively affect product performance and reliability.
- De-rate Power Dissipation depending on ambient temperature. When used in sealed area, confirm that it is the use in the range that does not exceed the maximum junction temperature.
- Confirm that operation temperature is within the specified range described in the product specification.
- ROHM shall not be in any way responsible or liable for failure induced under deviant condition from what is defined in this document.

Precaution for Mounting / Circuit board design

- When a highly active halogenous (chlorine, bromine, etc.) flux is used, the residue of flux may negatively affect product performance and reliability.
- In principle, the reflow soldering method must be used on a surface-mount products, the flow soldering method must be used on a through hole mount products. If the flow soldering method is preferred on a surface-mount products, please consult with the ROHM representative in advance.

For details, please refer to ROHM Mounting specification

Precautions Regarding Application Examples and External Circuits

1. If change is made to the constant of an external circuit, please allow a sufficient margin considering variations of the characteristics of the Products and external components, including transient characteristics, as well as static characteristics.
2. You agree that application notes, reference designs, and associated data and information contained in this document are presented only as guidance for Products use. Therefore, in case you use such information, you are solely responsible for it and you must exercise your own independent verification and judgment in the use of such information contained in this document. ROHM shall not be in any way responsible or liable for any damages, expenses or losses incurred by you or third parties arising from the use of such information.

Precaution for Electrostatic

This Product is electrostatic sensitive product, which may be damaged due to electrostatic discharge. Please take proper caution in your manufacturing process and storage so that voltage exceeding the Products maximum rating will not be applied to Products. Please take special care under dry condition (e.g. Grounding of human body / equipment / solder iron, isolation from charged objects, setting of Ionizer, friction prevention and temperature / humidity control).

Precaution for Storage / Transportation

1. Product performance and soldered connections may deteriorate if the Products are stored in the places where:
 - [a] the Products are exposed to sea winds or corrosive gases, including Cl₂, H₂S, NH₃, SO₂, and NO₂
 - [b] the temperature or humidity exceeds those recommended by ROHM
 - [c] the Products are exposed to direct sunshine or condensation
 - [d] the Products are exposed to high Electrostatic
2. Even under ROHM recommended storage condition, solderability of products out of recommended storage time period may be degraded. It is strongly recommended to confirm solderability before using Products of which storage time is exceeding the recommended storage time period.
3. Store / transport cartons in the correct direction, which is indicated on a carton with a symbol. Otherwise bent leads may occur due to excessive stress applied when dropping of a carton.
4. Use Products within the specified time after opening a humidity barrier bag. Baking is required before using Products of which storage time is exceeding the recommended storage time period.

Precaution for Product Label

A two-dimensional barcode printed on ROHM Products label is for ROHM's internal use only.

Precaution for Disposition

When disposing Products please dispose them properly using an authorized industry waste company.

Precaution for Foreign Exchange and Foreign Trade act

Since concerned goods might be fallen under listed items of export control prescribed by Foreign exchange and Foreign trade act, please consult with ROHM in case of export.

Precaution Regarding Intellectual Property Rights

1. All information and data including but not limited to application example contained in this document is for reference only. ROHM does not warrant that foregoing information or data will not infringe any intellectual property rights or any other rights of any third party regarding such information or data.
2. ROHM shall not have any obligations where the claims, actions or demands arising from the combination of the Products with other articles such as components, circuits, systems or external equipment (including software).
3. No license, expressly or implied, is granted hereby under any intellectual property rights or other rights of ROHM or any third parties with respect to the Products or the information contained in this document. Provided, however, that ROHM will not assert its intellectual property rights or other rights against you or your customers to the extent necessary to manufacture or sell products containing the Products, subject to the terms and conditions herein.

Other Precaution

1. This document may not be reprinted or reproduced, in whole or in part, without prior written consent of ROHM.
2. The Products may not be disassembled, converted, modified, reproduced or otherwise changed without prior written consent of ROHM.
3. In no event shall you use in any way whatsoever the Products and the related technical information contained in the Products or this document for any military purposes, including but not limited to, the development of mass-destruction weapons.
4. The proper names of companies or products described in this document are trademarks or registered trademarks of ROHM, its affiliated companies or third parties.

General Precaution

1. Before you use our Products, you are requested to carefully read this document and fully understand its contents. ROHM shall not be in any way responsible or liable for failure, malfunction or accident arising from the use of any ROHM's Products against warning, caution or note contained in this document.
2. All information contained in this document is current as of the issuing date and subject to change without any prior notice. Before purchasing or using ROHM's Products, please confirm the latest information with a ROHM sales representative.
3. The information contained in this document is provided on an "as is" basis and ROHM does not warrant that all information contained in this document is accurate and/or error-free. ROHM shall not be in any way responsible or liable for any damages, expenses or losses incurred by you or third parties resulting from inaccuracy or errors of or concerning such information.



BM1386GLV - Web Page

Part Number	BM1386GLV
Package	CLGA10V020A
Unit Quantity	3000
Minimum Package Quantity	3000
Packing Type	Taping
Constitution Materials List	inquiry
RoHS	Yes