

TROUBLESHOOTING

Problem:	Possible cause:	Solutions:
Door does not lock	No power	<ul style="list-style-type: none"> • Check to make sure the wires are connected properly. • Check that the power supply is connected and operating • Make sure the lock switch is wired correctly
Door locks, but can be easily forced open	Poor contact between electromagnet and armature plate	<ul style="list-style-type: none"> • Make sure the electromagnet and armature plate are properly aligned • Make sure the contact surfaces of the electromagnet and armature plate are clean and free from rust
	Insufficient voltage	<ul style="list-style-type: none"> • Check the power leads with a meter, and make sure power is supplied between 12-24VDC.
Delay in door releasing	A secondary diode was installed across the electromagnet	<ul style="list-style-type: none"> • The electromagnet is fitted with a metal oxide varistor to prevent interference, so do not install a secondary diode

REGULAR MAINTENANCE

- Clean the contact surfaces of the electromagnet or armature plate with a soft cloth and non-abrasive, non-corrosive cleaner.
- Apply a light coat of a silicon lubricant and wipe away the excess to prevent rust.
- Check that the armature plate is securely attached to the door, yet can pivot slightly around the armature screw.
- Check that the electromagnet is securely attached to the door frame.

LIFETIME LIMITED WARRANTY: This SECO-LARM product is warranted against defects in material and workmanship while used in normal service for the lifetime of the product. SECO-LARM's obligation is limited to the repair or replacement of any defective part if the unit is returned, transportation prepaid, to SECO-LARM. Under no circumstances will SECO-LARM be responsible for any costs or charges for removal, installation, or reinstallation.

This Warranty is void if damage is caused by or attributed to acts of God, physical or electrical misuse or abuse, neglect, repair, or alteration, improper or abnormal usage, or faulty installation, or if for any other reason SECO-LARM determines that such equipment is not operating properly as a result of causes other than defects in material and workmanship.

The sole obligation of SECO-LARM, and the purchaser's exclusive remedy, shall be limited to repair or replacement only, at SECO-LARM's option. In no event shall SECO-LARM be liable for any special, collateral, incidental, or consequential personal or property damages of any kind to the purchaser or anyone else.

This lifetime limited warranty is for products sold and installed in the United States and Canada. For all other countries the warranty is 1 (one) year.

NOTICE

The information and specifications printed in this manual are current at the time of publication. However, the SECO-LARM policy is one of continual development and improvement. For this reason, SECO-LARM reserves the right to change specifications without notice. SECO-LARM is also not responsible for misprints or typographical errors.

Copyright © 2011 SECO-LARM U.S.A., Inc. All rights reserved. This material may not be reproduced or copied, in whole or in part, without the written permission of SECO-LARM.

SECO-LARM® U.S.A., Inc.

16842 Millikan Avenue, Irvine, CA 92606

Tel: 800-662-0800 / 949-261-2999 Fax: 949-261-7326

Website: www.seco-larm.com

E-mail: sales@seco-larm.com

PITLW1
Filename: MIE941SA-80c.PMD

Installation Manual







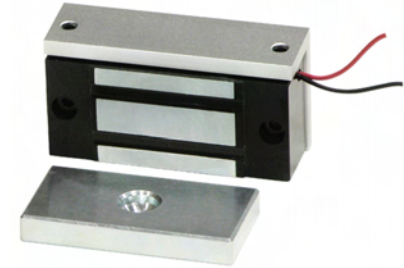

SECO-LARM

E-941SA-80Q

80-LB. MINIATURE ELECTROMAGNETIC LOCKS



Also available:

- E-941SA-300RQ** 300-lb Holding force
- E-941SA-300** 300-lb Holding force, weatherproof
- E-941SA-600** 600-lb Holding force 
- E-941SA-600PQ** 600-lb Holding force, bond sensor, LED 
- E-941SA-1200** 1,200-lb Holding force 
- E-941SA-1K2PD** 1,200-lb Holding force, bond sensor, LED 
- E-941DA-600** Double-door, 600-lb holding force 
- E-941DA-600PQ** Double-door, 600-lb holding force 
- E-941DA-1K2Q** Double-door, 1,200-lb holding force 
- E-941DA-1K2P** Double-door, 1,200-lb holding force, bond sensors, LED 
- E-941DA-1K2PD** Double-door, 1,200-lb holding force, bond sensors, LED, timer

HOW THEY WORK

When power is applied to the electromagnetic lock, it turns on the unit's powerful built-in electromagnet. This electromagnet is attracted to the steel armature plate which is mounted on a door, holding the door fast against unauthorized entry. When power to the magnetic lock is turned off, the electromagnet releases the armature plate, allowing the door to open.

SPECIFICATIONS

Power	12-24VDC
Magnet Size	2 ³ / ₄ x 1 ¹ / ₄ x 1 ³ / ₁₆ in. (70 x 31 x 20 mm)
Armature Size	2 ³ / ₈ x 1 ¹ / ₄ x 2 ³ / ₆₄ in. (60 x 31 x 9 mm)
Holding Force	80 lb. (36kg.) @ 12VDC 110lb.(51Kg.) @ 24VDC
Current Drain	85mA @ 12VDC 165mA @ 24VDC
Voltage Tolerance	± 10%
Housing	Aluminum
Temperature	14°F to 131°F (-10°C to 55°C)
Weight	0.90 lb. (410 grams)

MOUNTING THE E-941SA-80Q

- A. Drill holes for the mounting plate and armature plate (see fig. 1 and 2) by doing the following:
 1. Fold the mounting template along the dotted line
 2. Close the door. Find a mounting location on the door frame near the upper free-moving corner of the door, as close to the corner of the door frame as possible.
 3. Place the template against the door and frame.
 4. Drill two holes in the door frame for the mounting plate and three holes in the door as indicated on template.
 5. Only from the sexnut bolt side of the door, enlarge the 5mm hole to 9mm.
- B. Mount the armature plate to the door using the two steel and one rubber washer (fig. 2):

NOTE — Actual installation varies according to door style.

 1. Secure the two guidepins into the two side holes of the armature plate.
 2. Insert the armature screw into the armature plate, then put the rubber washer between two steel washers, and place them over the armature screw between the armature plate and the door. This will allow the armature plate to pivot slightly around the armature screw in order to compensate for door misalignment.
 2. Insert the sexnut bolt into the 9mm hole, then tighten the sexnut bolt and the armature screw, just enough so the armature plate can withstand the force of someone attempting to break down

the door while the electromagnet is engaged.

- 3. Do not tighten the armature plate against the door. The plate must be able to pivot around the armature screw.
- C. Screw the mounting plate to the door frame:
 1. Remove the L-shaped mounting plate from the magnet.
 2. Insert the provided two 1/8" x 1" (4 x 25.4 mm) screws into the L-shaped mounting plate and screw it to the door frame. The armature plate and the mounting plate must be concentric or align with each other.
- D. Drill the power cable access hole.
- E. Mount the electromagnet to the door frame (fig. 1) — Use the Allen wrench to screw the socket-head mounting screws through the bottom of the electromagnet into the mounting bracket.

- F. Connect the power leads (fig. 3):
 1. Run two power leads from the power supply through the power cable access hole into the electromagnet.
 2. Connect the power leads to the red and black power input wires of the unit. Observe correct polarity, red for positive and black for negative.

- G. Test the unit.

FIG.1 Standard Mounting

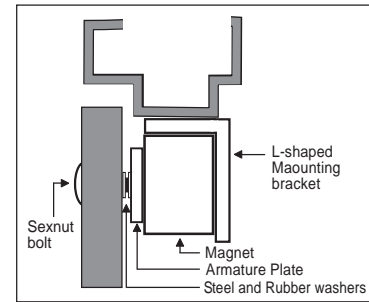

FIG. 2 Types of armature plate mounting

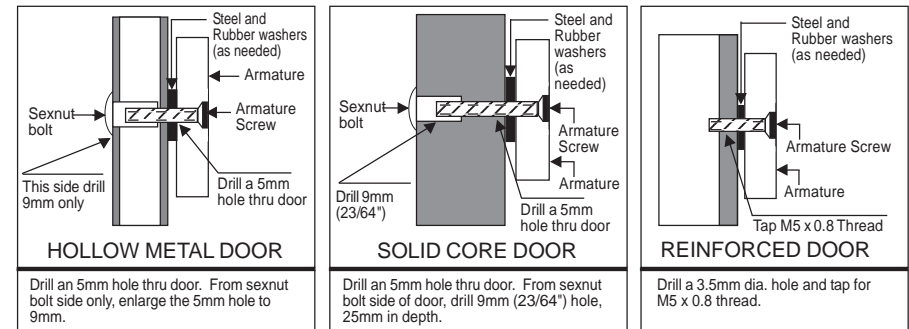

FIG. 3 Wiring diagram

