

# Inclinometer

## B1N360V-Q20L60-2LU3-H1151

**TURCK**  
*works*

Industrial  
Automation

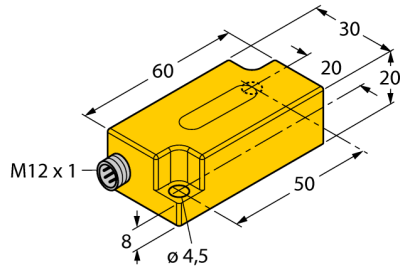

- Rectangular, plastic, PC
- Compact housing
- Connection via M12 × 1 male
- Response time 0.1 s
- 10...30 VDC
- Two counter-running 0.1 ... 4.9 V analog outputs improve machine safety through redundancy

### Wiring Diagram

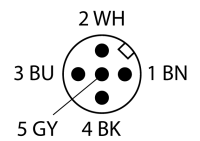
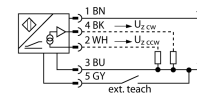

<b>Type designation</b>	B1N360V-Q20L60-2LU3-H1151
Ident-No.	1534069
Ident-No (TUSA)	M1534069

<b>Measuring range</b>	0...360°
Mounting conditions	Vertical
Repeatability	≤ 0.2 % of measuring range  A - B
Linearity deviation	≤ 0.6 %
Temperature drift	≤ ± 0.05 % / K
Resolution	≤ 0.14 °
Ambient temperature	-30...+70 °C

<b>Operating voltage</b>	10...30 VDC
Isolation test voltage	≤ 0.5 kV
Short-circuit protection	yes
Wire breakage/Reverse polarity protection	yes/ Complete
Output function	5-pin, Analog output
Voltage output	0.1...4.9V
	2 outputs, one for CW and one for CCW
Load resistance voltage output	≥ 40 kΩ
Response time	0.1 s
	Time for the output signal to reach 90% of the adjusted measuring range
Current consumption	50...105 mA (voltage-dependent)

<b>Design</b>	Rectangular, Q20L60
Dimensions	60 x 30 x 20 mm
Housing material	Plastic, PC
Electrical connection	Connector, M12 × 1
Vibration resistance	55 Hz (1 mm)
Shock resistance	30 g (11 ms)
Protection class	IP68/IP69K
MTTF	203 years acc. to SN 29500 (Ed. 99) 40 °C

### Functional principle

The TURCK inclinometers incorporate a micro-mechanical pendulum, operating on the principle of MEMS technology (Mikro Elektro Mechanic Systems).

The pendulum basically consists of two 'plate' electrodes arranged in parallel with a dielectric placed in the middle. When the sensor is inclined, the dielectric in the middle moves, causing the capacitance ratio between both electrodes to change.

The downstream electronics evaluates this change in capacitance and generates a corresponding output signal.

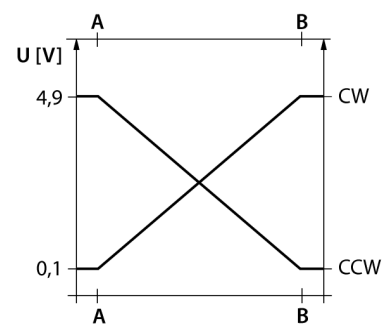

# Inclinometer B1N360V-Q20L60-2LU3-H1151

**TURCK**  
*works*

Industrial  
Automation

Mounting instructions/Description

Tilt angle

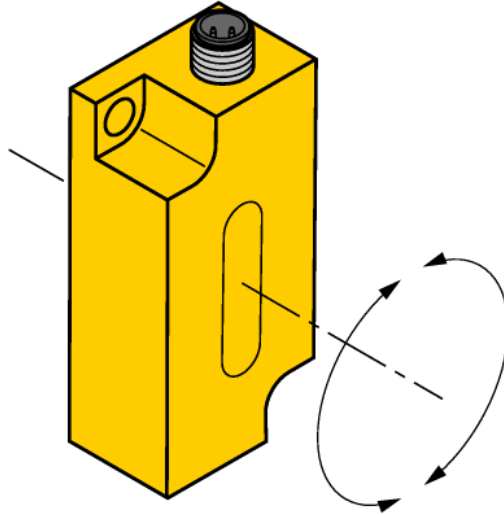

Adjusting the measuring range via TX1-Q20L60 teach adapter

Setting the angular range in CW direction:

- Move sensor to start position
- Press and hold Teach-Gnd until the output is set to 0.1 V (approx. 1 s)
- Move sensor to end position
- Press and hold Teach-Gnd until the output is set to 4.9 V (approx. 3 s)

Resetting the angular range:

- Press and hold Teach-Gnd until the output is set to 2.5 V (approx. 6 s)
- Angle measurement is set back to 360° degrees (in mounting position "connector outgoing upwards" the sensor provides an output signal in accordance with 0° degrees)

**Inclinometer**  
**B1N360V-Q20L60-2LU3-H1151**



**Accessories**

Type code	Ident-No.	Description	
IM43-13-SR	7540041	Trip amplifier; 1-channel; input 0/4...20 mA or 0/2...10 V; supply of 2- or 3-wire transmitters/sensors; limit value adjustment via teach button; three relay outputs with one NO contact each; removable terminal blocks; 27 mm wide; universal voltage supply 20...250 VUC; further Limit value indicators are described in our "Interface Technology" catalog.	
SG-Q20L60	6901100	Protective frame for Q20L60; protects against mechanical impact; stainless steel	
TX1-Q20L60	6967114	Teach adapter for inductive encoders, linear position, angle, ultrasonic and capacitive sensors	