

Type: **T5B-1-102/14**

Article No.: **207215**



Ordering information

Design			Surface mounting
Description			Without auxiliary contacts
Main conducting paths No. of poles		M	2
Auxiliary contacts		N/O	0
Auxiliary contacts		B	0
Max. three-phase motor rating (per set of 3 contacts) 50–60 Hz AC–3 400/415 V 50–60 Hz	<i>P</i>	kW	22
Rated uninterrupted current	I_u	A	63

Contact sequence

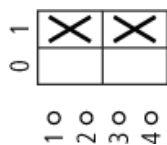

General

Standards			IEC/EN 60947, VDE 0660, IEC/EN 60204, CSA, UL Switch-disconnectors to IEC/EN 60947-3 Load-break switches to IEC/EN 60947-3
Lifespan, mechanical	Operations	$\times 10^6$	0,5

Maximum operating frequency	Operations/h		3000
Climatic proofing			Damp heat, constant, to IEC 60068–2–78; Damp heat, cyclical, to IEC 60068–2–30
Ambient temperature			
Open		° C	–25/50
Enclosed		° C	–25/40
Mounting position			As required
Documentation			Main catalogue HPL
Mechanical shock resistance (shock duration 20 ms)		g	> 15

Contacts

Rated operational voltage	U_e	V AC	690
Rated impulse withstand voltage	U_{imp}	V AC	6000
Overtoltage category/pollution degree			III/3
Rated uninterrupted current			
open	I_u	A	63
Enclosed	I_u	A	63
Load-carrying capacity in intermittent operation, Class 12			
AB 25 % DF		$\times I_e$	2
AB 40 % DF		$\times I_e$	1,6
AB 60 % DF		$\times I_e$	1,3
Short-circuit rating			
Fuse		A gG/gL	80
Rated short-time withstand current (1 s current)	I_{cw}	A_{rms}	1300
Safe isolation to VDE 0106 Part 101 and Part 101/A1			
between the contacts		V AC	440
Switching angles		°	90 60 45 30
Contact units			10
Double-break contacts			max. 20
Current heat loss per contact at I_e		W	4,5

Terminal capacities

Solid or stranded		mm ²	1 × (2.5 – 35) 2 × (2.5 – 16)
-------------------	--	-----------------	----------------------------------

Flexible with ferrule to DIN 46228		mm ²	1 × (1.5 – 25) 2 × (1.5 – 10)
Terminal screw			M6
Tightening torque		Nm	4
Switching capacity			
AC			
Rated making capacity $\cos \phi = 0.35$		A	800
Rated breaking capacity, motor load switch $\cos \phi = 0.35$			
230 V		A	520
400 V		A	600
500 V		A	480
690 V		A	340
Rated operational current 440 V load-break switch AC-21A	I_e	A	63
AC-3 motor load switch motor rating			
230 V	P	kW	7,5
230 V Star-delta	P	kW	22
400 V	P	kW	11
400 V Star-delta	P	kW	37
500 V	P	kW	22
500 V Star-delta	P	kW	37
690 V	P	kW	22
690 V Star-delta	P	kW	37
AC-23A Motor load switches (main switches maintenance switches)			
230 V	P	kW	15
400 V	P	kW	22
500 V	P	kW	22
690 V	P	kW	22
Rated operational current control switch AC-15			
230 V	I_e	A	16
400 V	I_e	A	6
500 V	I_e	A	4
DC			
DC-1, Load-break switches L/R = 1 ms			

Rated operational current	I_e	A	63
Voltage per contact pair in series		V	60
DC–23A, Motor load switches L/R = 15 ms			
24 V			
Rated operational current	I_e	A	50
Contacts		Quantity	1
48 V			
Rated operational current	I_e	A	50
Contacts		Quantity	2
60 V			
Rated operational current	I_e	A	50
Contacts		Quantity	3
120 V			
Rated operational current	I_e	A	25
Contacts		Quantity	3
240 V			
Rated operational current	I_e	A	20
Contacts		Quantity	6
DC–13, Control switches L/R = 50 ms			
Rated operational current	I_e	A	25
Voltage per contact pair in series		V	24
Control circuit reliability at 24 V DC, 10 mA	Fault probability	H_F	$< 10^{-5}$, < 1 fault in 100000 operations

Notes

			<p>For mechanical shock resistance: T3.../I... >12g Applies to T0(3).../SVB: isolating characteristics to IEC/EN 60947 U for rated operational voltage up to 500 V AC Applies to rated uninterrupted current I_u of the contact: with T5–4–8344/I5 max. 95 A For terminal capacity solid, stranded and flexible: T0(3), (6), (8)...: Maximum of 2 cross-section sizes difference admissible between 2 conductors T5(B)–...: Maximum of 1</p>
--	--	--	--

		cross-section size difference admissible between 2 conductors For type T8-3-8342/... the following applies: switching angle = 90° and flat connection = 1 busbar 25 x 5 or 2 busbars 20 x 3
Dimensions		
		Depth of one contact unit: 16.5 mm
Explanation		For utilisation category AC-4 (extreme load: 100 % inching, reversing or plugging) The blocked rotor current of the motor should not exceed the rated current of the switch for AC-21A to ensure a reasonable device lifespan.

Dimensions

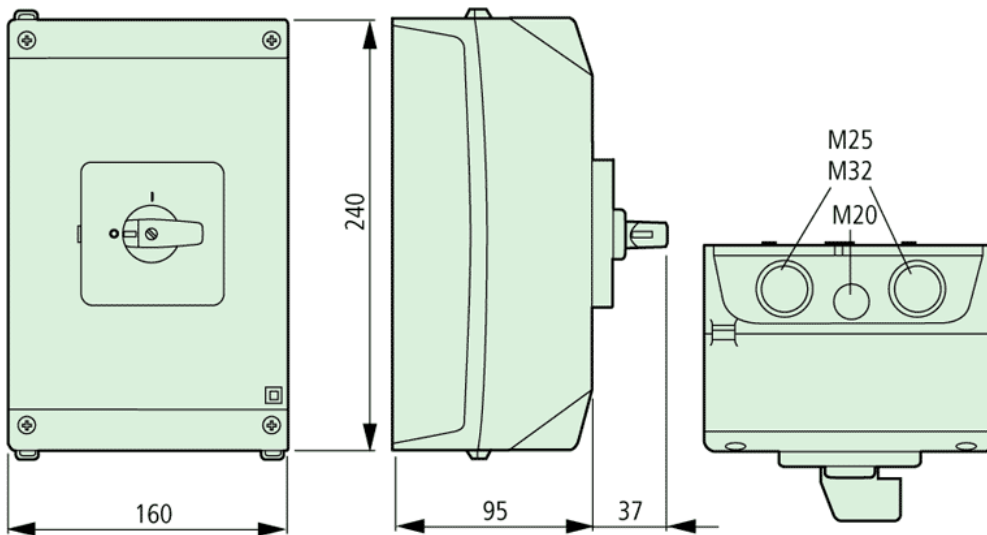

Dimensions

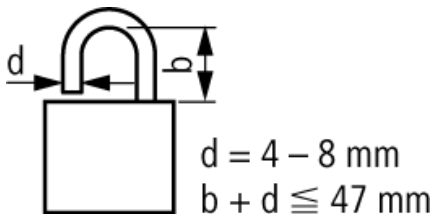

Characteristic curve

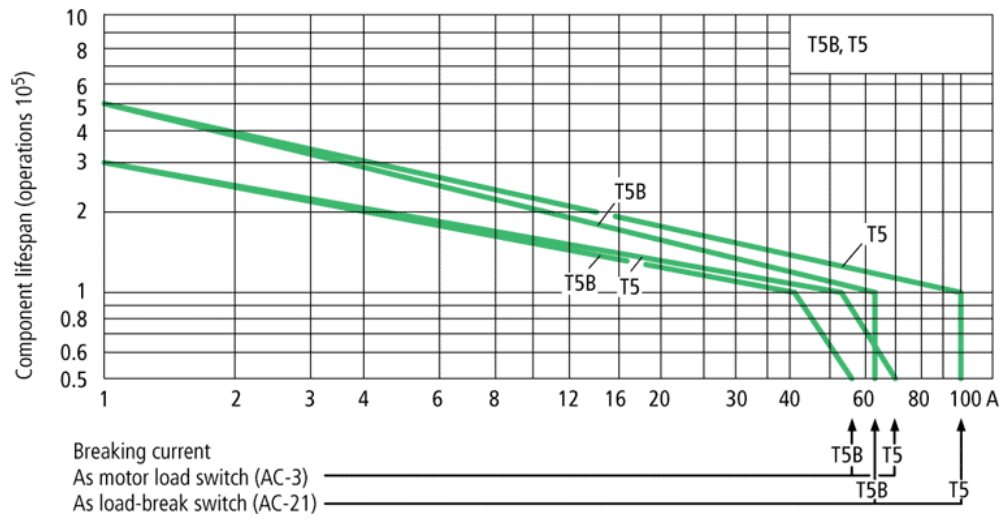

Moeller GmbH, Hein-Moeller-Str. 7-11, D-53115 Bonn
 E-Mail: catalog@moeller.net, Internet: www.moeller.net, <http://catalog.moeller.net>
 Copyright 2006 by Moeller GmbH. Subject to modifications. HPL-C2006GB-INT V2.3