

Thermal Overload Relay



Operating Characteristics

Type	*	MCTR2-D18321	MCTR2-D25322	Unit
Temperature Compensation	-20 ~ +60	-30 ~ +60	-30 ~ +60	°C
Tripping Threshold	Conforming to IEC 6047-4-1	1.14 ±0.061n		A
Sensitivity to phase failure	Conforming to IEC 60947-4-1	Tripping current 25% above I _n		-

*MCTR2-D09306; MCTR2-D09307; MCTR2-D09308; MCTR2-D09310; MCTR2-D09312; MCTR2-D09314; MCTR2-D12316

Auxiliary Contact Characteristics

Type		Values	Unit
Conventional thermal Current		5	A
Maximum consumption of operating	AC Supply	24 48 110 220 380 600	V
Coil of controlled contactors (Occasional operating cycles of contact 95 - 96)		100 200 400 600 600 600	VA
		24 48 110 220 440 -	V
Short circuit protection	By gG or BS fuse Max. rating or by GB2 circuit-breaker	100 100 50 45 25 -	W
		5	A
Connection to screw clamp terminal	Minimum / Maximum GSA		-
Flexible cable without cable end	1 or 2 conductors	1 / 2.5	mm ²
Flexible cable with cable end	1 or 2 conductors	1 / 2.5	mm ²
Solid cable without cable end	1 or 2 conductors	1 / 2.5	mm ²
Tightening torque	1 or 2 conductors	1.85	Nm
Connecting to spring terminal	Minimum / Maximum GSA		-
Flexible cable without cable end	1 or 2 conductors	1 / 2.5	mm ²
Solid cable without cable end	1 or 2 conductors	1 / 2.5	mm ²

Electrical Characteristics of Power Circuit

Type	*	MCTR2-D18321	MCTR2-D25322	Unit
Tripping class	10	10	10	A
Rated insulation Voltage (U _i)	Conforming to IEC 6094 7-4-1	690	690	V
Rated operating voltage upto	Conforming to UL, GSA	600	600	V
Rated impulse withstand voltage (U _{imp})	6	6	6	kV
Frequency limits	Of the operational current	0 ~ 400	0 ~ 400	Hz
Setting range	Depending on model	0.1 ~ 13	12 ~ 38	A

*MCTR2-D09306; MCTR2-D09307; MCTR2-D09308; MCTR2-D09310; MCTR2-D09312; MCTR2-D09314; MCTR2-D12316

Thermal Overload Relay



Type	*	MCTR2-D18321	MCTR2-D25322	Unit
Connecting to screw clamp terminal	Minimum / Maximum GSA			-
Flexible cable without cable end	1 conductor	1.5 / 10	1.5 / 10 4 / 35	mm ²
Flexible cable with cable end	1 conductor	1 / 4	1 / 6 except MRTR2-D18321: 1/4 4 / 35	mm ²
Solid cable without cable end	1 conductor	1 / 6	1.5 / 4 except MRTR2-D18321:1/6 4 / 35	mm ²
Tightening torque		1.7	2.5	Nm
Connection to spring terminals	Minimum / Maximum GSA			-
Solid Cable without cable end	1 conductor	1.5 / 4	1.5 / 4	mm ²

*MCTR2-D09306; MCTR2-D09307; MCTR2-D09308; MCTR2-D09310; MCTR2-D09312; MCTR2-D09314; MCTR2-D12316

Environment

Conforming to standards	IEC 60947-1, IEC 60947-4-1, NFC 63-650, VDE 0660, BS 4941	
Approvals	UL, CSA, IEC	
Degree of protection	Conforming to VDE 0106	Protection against direct finger contact IP 2X
Protective treatment	Conforming to IEC 68	"TH"
Ambient air temperature (around the device)	Storage	-60°C to +70°C
	Operation, without derating	-25°C to +60°C
	Max. & Min. operating temp.	-40°C to +70°C
Operating position	Without derating	Any Position, in relation to normal vertical mounting plane
Shock resistance	Permissible acceleration	15gn - 11 ms, conforming to IEC 68-2-7
Vibration resistance	Permissible acceleration	6gn, conforming to IEC 68-2-6
Dielectric strength at 50 Hz	Conforming to IEC 255-5	6kV
Impulse withstand voltage	Conforming to IEC 801-5	6kV

Overload Relay (Class 10)

Part Number	Relay Setting Range (A)	Standard power ratings of 3-phase motors 50~60Hz AC3 Category					Back Up	
		220V	380V	415V	440V	660V	Fuse Rating	
		kW	kW	kW	kW	kW	aM (A)	g1 (A)
MCTR2-D09306	1 to 1.6	-	0.37	-	0.55	1.1	2	4
MCTR2-D09307	1.6 to 2.5	0.37	0.75	1.1	1.1	1.5	4	6
MCTR2-D09308	2.5 to 4	0.75	1.5	1.5	1.5	3	6	10
MCTR2-D09310	4 to 6	1.1	2.2	2.2	2.2	4	8	16
MCTR2-D09312	5.5 to 8	1.5	3	3.7	3.7	5.5	12	20
MCTR2-D09314	7 to 10	2.2	4	4	4	7.5	12	20
MCTR2-D12316	9 to 13	3	5.5	5.5	5.5	10	16	25

Thermal Overload Relay



Part Number	Relay Setting Range (A)	Standard power ratings of 3-phase motors 50~60Hz AC3 Category					Back Up	
		220V	380V	415V	440V	660V	Fuse Rating	
		kW	kW	kW	kW	kW	aM (A)	g1 (A)
MCTR2-D18321	12 to 18	4	7.5	9	9	15	20	35
MCTR2-D25322	17 to 25	5.5	11	11	11	18.5	25	50

Dimensions

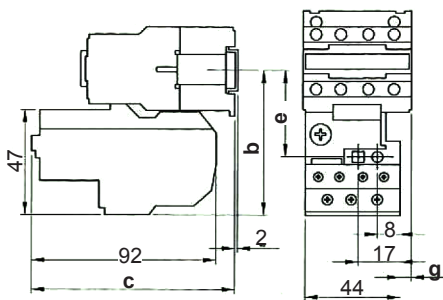

Part Number	b	c	e	g
MCTR2-D09306	81	98	50	0
MCTR2-D09307				
MCTR2-D09308				
MCTR2-D09310				
MCTR2-D09312				
MCTR2-D09314				
MCTR2-D12316				
MCTR2-D18321				
MCTR2-D25322	86mm	108	55	10.7

Dimensions : Millimetres

Part Number Table

Description	Part Number
Thermal Overload Relay, 1 ~ 1.65A	MCTR2-D09306
Thermal Overload Relay, 1.6 ~ 2.5A	MCTR2-D09307
Thermal Overload Relay, 2.5 ~ 4A	MCTR2-D09308
Thermal Overload Relay, 4 ~ 6A	MCTR2-D09310
Thermal Overload Relay, 5.5 ~ 8A	MCTR2-D09312
Thermal Overload Relay, 7 ~ 10A	MCTR2-D09314
Thermal Overload Relay, 9 ~ 13A	MCTR2-D12316
Thermal Overload Relay, 12 ~ 18A	MCTR2-D18321
Thermal Overload Relay, 17.25A	MCTR2-D25322

Important Notice : This data sheet and its contents (the "Information") belong to the members of the Premier Farnell group of companies (the "Group") or are licensed to it. No licence is granted for the use of it other than for information purposes in connection with the products to which it relates. No licence of any intellectual property rights is granted. The Information is subject to change without notice and replaces all data sheets previously supplied. The Information supplied is believed to be accurate but the Group assumes no responsibility for its accuracy or completeness, any error in or omission from it or for any use made of it. Users of this data sheet should check for themselves the Information and the suitability of the products for their purpose and not make any assumptions based on information included or omitted. Liability for loss or damage resulting from any reliance on the Information or use of it (including liability resulting from negligence or where the Group was aware of the possibility of such loss or damage arising) is excluded. This will not operate to limit or restrict the Group's liability for death or personal injury resulting from its negligence. Multicomp is the registered trademark of the Group. © Premier Farnell Limited 2016.

www.element14.com
www.farnell.com
www.newark.com

