

OPTIONS



VERSIONS

Type	Force N	Feed mm/s	Resolution $\mu\text{m}/\text{step}$	Current per Winding A	Resistance per Winding Ohm	Screw Length mm	Weight kg
LS4118S1404-T6x1	350	40	5	1.4	2	75/150	0.22/0.24
LS4118S1404-T6x2	250	55	10	1.4	2	75/150	0.22/0.24
LS4118S1404-T5x5	120	65	25	1.4	2	75/150	0.22/0.24

ORDER IDENTIFIER

LS4118S1404-T6x1-

150 = 150 mm Screw Length
75 = 75 mm Screw Length



ACCESSORIES

LSNUT-T5X5-F Threaded Nut
LSNUT-T6X1-F Threaded Nut
LSNUT-T6X2-F Threaded Nut
Nanolube Lubricant



CAUTION



The force and power ratings specified in the data sheets are based on a duty cycle of 10% to 20% and must be reduced for higher values. Moving against fixed end stops should be avoided.

DIMENSIONS (IN MM)

LS4118

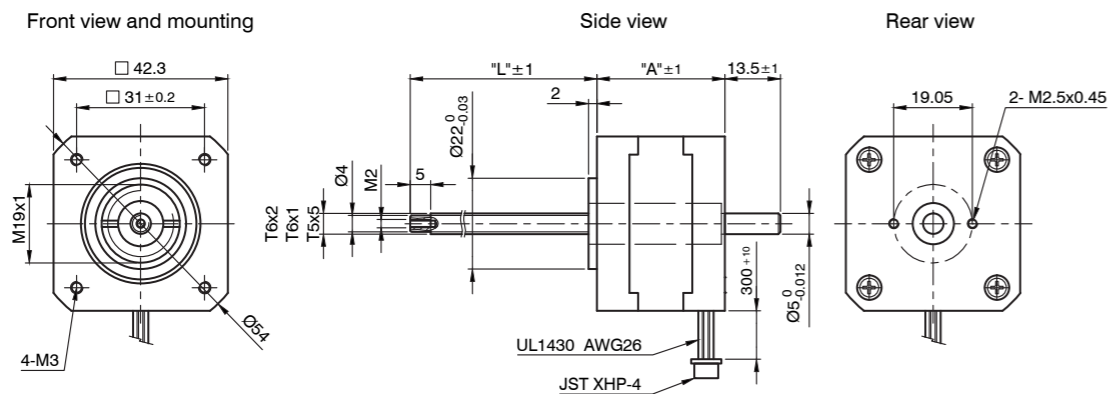

TORQUE CURVES

LS4118S1404-T6x1

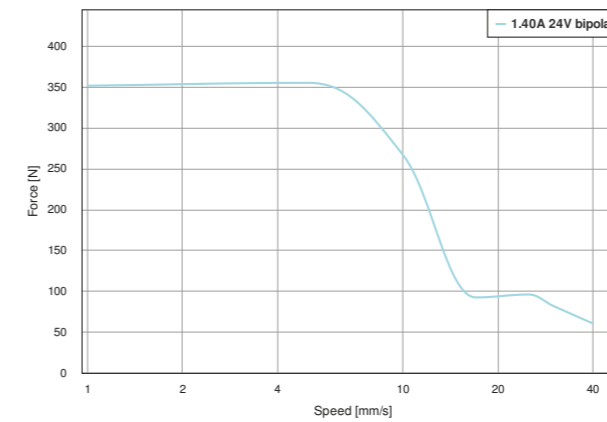

LS4118S1404-T6x2

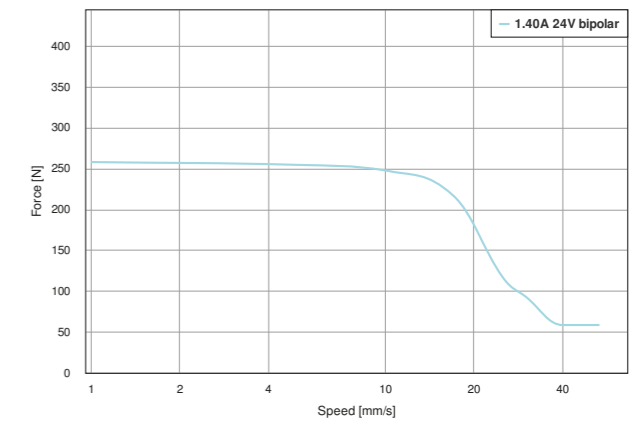

LS4118S1404-T5x5

