

PRESSURE COMPENSATION DEVICE (STAINLESS STEEL)

DA 284 | IP66



Photo: Inside view

- > High degree of protection
- > Waterproof membrane
- > Corrosion resistant
- > Food safe

Pressure differentials in enclosures with a high degree of protection are a result of internal and external temperature changes. In the case of negative pressure or partial vacuum, dust and humidity can enter the enclosure through the door seal. When the air inside the enclosure cools down, condensation may occur because the humidity cannot escape the enclosure. The easy-to-install pressure compensation device DA 284 provides compensation of pressure at a protection degree of IP66. Even with a slight overpressure, a waterproof membrane inside the plug allows the humidity to escape whilst blocking water and dirt from entering the enclosure.



TECHNICAL DATA

Mounting	thread M40 x 1.5 with nut
Torque	5 Nm
Depth in enclosure	approx. 9 mm
Sealing	sealing gasket NBR
Filter	waterproof membrane
Air permeability	1,200 l/h at a pressure difference of min. 70mbar
Dimensions	Ø 58 x 31 mm
Fitting position	variable
Operating/Storage temperature	-45 to +80 °C (-49 to +176 °F)
Approvals	EAC

Installation: Make cut-out Ø 40.5^{+0.5} mm in enclosure wall and mount pressure compensation device with nut. Please make sure that the sealing gasket is put in place on the outer side panel of the enclosure. For optimal pressure compensation we recommend to use two devices on opposite sides towards the top of the enclosure.

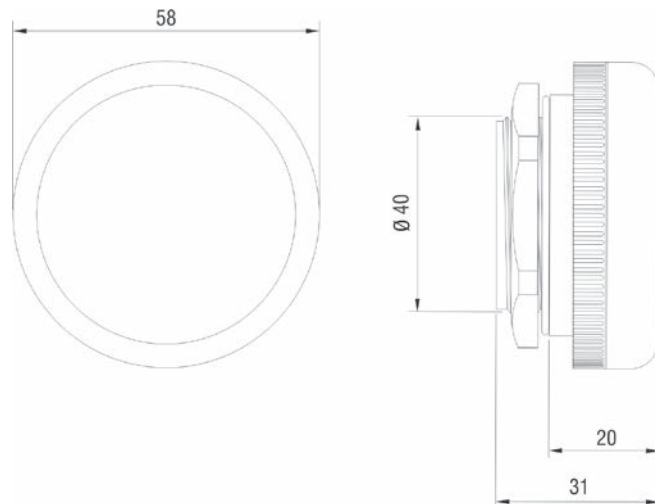

Art. No.	Stainless steel	Protection type	1 packaging unit	Weight (approx.)
28401.0-00	V2A (DIN 1.4301 / AISI 304) ¹	IP66 (EN 60529) / IPX9K (EN 40050-9)	1 piece	0.2 kg
28401.0-02	V4A (DIN 1.4404 / AISI 316L)	IP66 (EN 60529) / IPX9K (EN 40050-9)	1 piece	0.2 kg

¹V2A is not sea waterproof