



MPN	VRM
DESCRIPTION	Voltage Regulator Module 6A of current at 5V or 3.3V

Overview

The Digilent VRM (Voltage Regulator Module) is a battery-friendly switching voltage regulator capable of providing up to 6A of current at 5V or 3.3V. The input voltage can be stepped down from sources as high as 15V. It is ideal for use in mechatronics applications to efficiently regulate battery voltage, or in any application where a clean step down is required.

Features include:

- Up to 6A synchronous step down switching regulator
- Selectable 5V or 3.3V output voltage
- Input voltage range of 5-15V
- 479kHz internal switching frequency
- Switching synchronization to an external clock

1. Functional Description

The Digilent VRM is designed to provide regulated 5V or 3.3V power using an external power source such as a battery. The 6A maximum current is ideal for application from small control boards to large mechatronics projects. In particular, it is useful for projects utilizing Digilent boards requiring a 5V source, as both the 5V external rail and the 3.3V internal regulation can be achieved.

Note: The 6A output current rating depends on operating temperature. It may be necessary to provide additional heat sinking or fan cooling to achieve the full 6A output current in some situations.

The VRM uses a Texas Instruments TPS54620 switching regulator. Refer to the data sheet available from Texas Instruments for detailed information about this regulator.

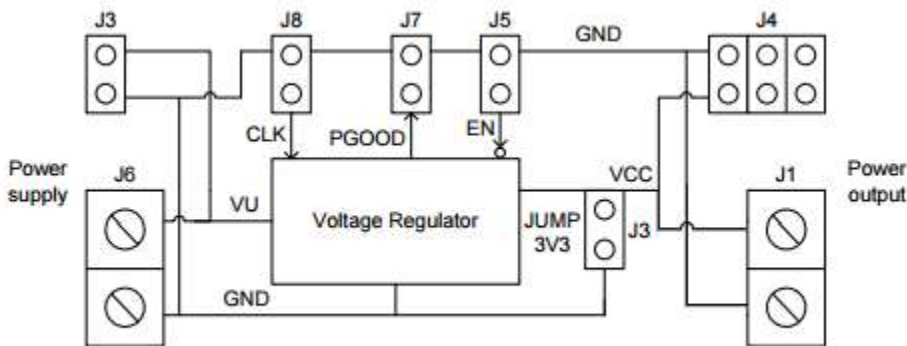

Refer to the schematic for detailed information about the circuitry on the board and the input, output, and configuration connections on the board.

2. Input and Output Connections

The VRM board has power inputs and outputs in both screw terminal and two-pin header format. Connect the external power source to the connections labeled “GND” and “VU” on the screw terminal connector J6, or the two-pin header, J3, labeled “BATTERY”. Observe proper polarity in making the connections, as reversed polarity will damage the VRM. Digilent has battery packs available with connectors suitable for the two-pin header.

Note: the screw terminal connector J6 is rated for up to 10A of current but the two pin header J3 is only rated for 2A. Do not use the VRM in configurations where more than 2A of input current will pass through J3.

The input current to the regulator is a function of the voltage ratio between input and output voltage, output current, and regulator efficiency. The following formula applies:

$$I_i = ((V_o/V_i) * I_o) / e$$

Where: I_i & I_o are input and output current, V_i & V_o are input and output voltage, and e is the regulator efficiency. The efficiency depends on several factors, but a value of 0.9 is reasonable. Refer to the TI data sheet for the TPS54620 for more information.

Screw terminal connector, J1, and the three two-pin headers of J4 provide access to the regulated output voltage. Digilent has available two-wire MTE power cables that are ideal for connections to the two-pin headers. As noted above, the screw terminal connector is rated for up to 10A, but the two pins headers are only rated for 2A each. Do not attempt to draw more than 2A on these connectors as they will get very hot and may fail.

Observe proper polarity when connecting the outputs of the VRM to the circuit being powered. The polarity markings for J4 are on the top of the board near J4. The polarity markings for J1 are on the bottom of the board.

3. Jumper Options

Several jumpers are used to configure or control the operation of the Digilent VRM:

Jumper J2 is used to select the output voltage. Install a shorting block on J2 to select 3.3V output. Otherwise the voltage output is 5V.

Connector J5 allows access to the enable input to the regulator. This allows an external controller, (such as a microcontroller) to turn the regulator on or off. Driving the EN pin on this connector to ground will turn off the regulator. Allowing this pin to float will turn the regulator on. The pin can also be used to provide an undervoltage lockout. Refer to the data sheet for the TPS54620 for more information.

Connector J8 can be used to provide an external clock signal to control the switching frequency of the regulator. Connecting the CLK pin on J8 to an external clock will cause the VRM's switching supply to synchronize to the external clock source. The external clock must be a square wave between 200 kHz and 1600 kHz. The amplitude of this signal must transition below 0.8V and above 2.0V. If the CLK pin is left disconnected, the supply will switch at 479 kHz.

Connector J7 provides access to the PGOOD signal out of the regulator. The PGOOD pin on J7 provides the status of the VRM output voltage. This pin floats during normal operation. The pin is driven low to indicate a power supply fault. This occurs when the VRM's reference voltage is below 91% or above 109% of normal. The PGOOD pin should be connected to a pull-up resistor to avoid erroneous fault detection.