



SERIES 35-2 PCB TAINER

WEIGHT

.37g/cm (.033 oz/in)

MATERIALS AND FINISH

HOUSING

Material:

.008-in. (.20-mm) thick
Beryllium Copper per
ASTM B-194 or Stainless
Steel per ASTM A-366

Finish:

See finish table on
opposite page

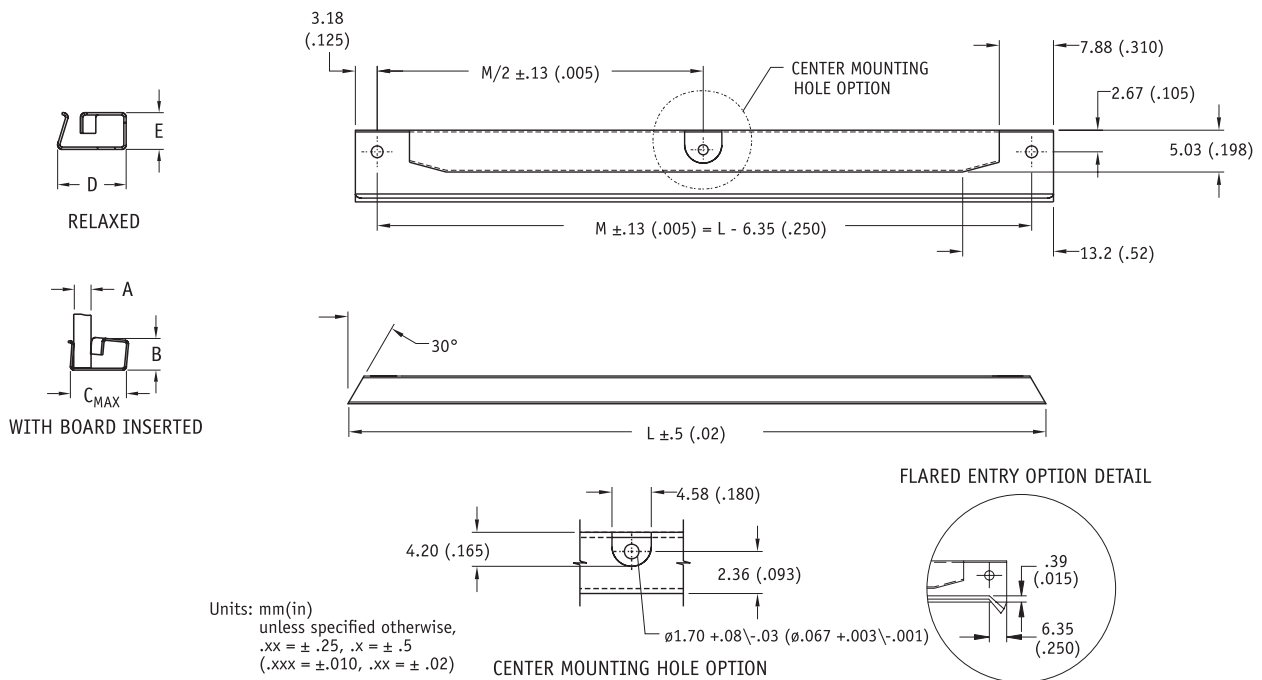
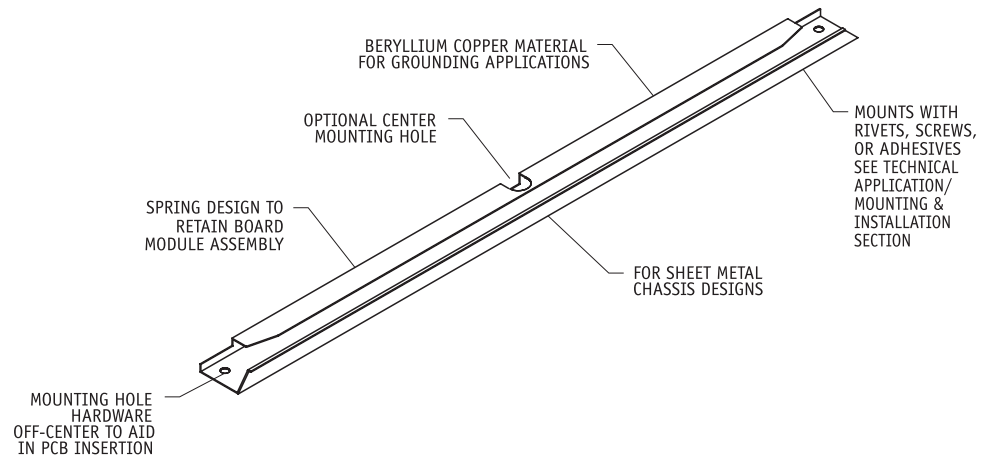

MATERIALS TABLE

CODE LETTER	MATERIAL
B	BERYLLIUM COPPER, 1/4H PER ASTM-B-194
BH	BERYLLIUM COPPER, 1/4HT PER QQ-C-533, HEAT TREATED
CR	STAINLESS STEEL, TYPE 301 COND 1/4 H PER AMS 5517

DIMENSION TABLE

DASH #	BOARD THICKNESS				
	A	B	C MAX	D	E
-1	0.79 (.031)	3.31 (.130)	8.13 (.320)	7.57 (.298)	3.18 (.125)
-2	1.60 (.063)	3.31 (.130)	8.13 (.320)	7.57 (.298)	3.18 (.125)
-3	2.39 (.094)	3.31 (.130)	9.15 (.360)	7.57 (.298)	3.18 (.125)
-4	3.18 (.125)	3.31 (.130)	9.40 (.370)	8.87 (.349)	3.18 (.125)

FINISH TABLE

DASH #	FINISH
[blank]	SILVER PLATE PER QQ-S-365, TYPE III, GRADE A
-1	NONE
-2	EBANOL PER MIL-F-495 FOR BERYLLIUM COPPER PER MIL-C-13924 FOR STEEL
-3	CADMIUM PER QQ-P-416, TYPE 2, CLASS 2
-4	COPPER PLATE PER MIL-C-14550, CLASS 2
-5	GOLD PLATE PER MIL-G-45204, TYPE 1, GLASS 1
-6	NICKEL PLATE PER QQ-N-290, CLASS 1, GRADE G, BRIGHT
-7	ZINC PLATE CLEAR CHROMATE, PER ASTM-B-633, Fe/Zn 8
-8	ZINC PLATE YELLOW CHROMATE, PER ASTM-B-633, Fe/Zn 8

Part Number Code

Series 35-2 Low Profile PCB-TAINER **35 C F - 2 B - 2 - 10 - 5**

Center Mounting Hole:
 Center Mounting Hole: _____ **C**
 None: _____ **[Blank]**

Flared Entry
 Flared Entry: _____ **F**
 None: _____ **[Blank]**

Material
 Beryllium Copper _____ **B**
 or select from Materials Table

Board Thickness
 1.59 (.063) PCB Thickness _____ **2**
 or select from Dimension Table

Length
 Length in 12.7 (.50) increments _____ 4 [50.8 (2.00)]
 _____ to 12 [152.4 (6.00)]

Finish
 Gold Plate _____ **5**
 or select from Finish Table

No dash number required for CR material. Stainless steel parts are passivated only.

Part Number Code example: 35C-2B-2-8-7

Series 35-2 Low Profile PCB-TAINER, Beryllium Copper, with Center Mounting Hole, .063-in. (1.60-mm) thick board, 101.6-mm (4.00-in.) long, Zinc Plate Clear Chromate finish.

