

groov Analog Current Input Module

Features

- > 24 channels per module
- > Module cover with LED indicates module status
- > Touch-sensitive pad triggers display of module information on groov EPIC® processor
- > UL Hazardous Locations approved and ATEX compliant
- > Guaranteed for life



GRV-IMA-24 Analog Input Module

DESCRIPTION

groov I/O modules are part of the groov EPIC® (Edge Programmable Industrial Controller) system. Wired directly to field devices (sensors and actuators), groov I/O translates the electrical signals from those devices into the digital language computers understand—so you can monitor and control devices and use their data wherever you need it, in your local computer network or in cloud services.

The **GRV-IMA-24** module provides 24 channels of analog current input with an input range of ± 20 mA, 0–20 mA, and 4–20 mA. The 24 channels are divided into two zones, with one zone isolated from the other zone.

Wiring is simplified with a top-mounted connector, which provides spring-clamp terminals for power, common, and field wiring. The connector is held in place by a single, captive retention screw but can be removed with the field wiring intact for wiring in advance or easier module field replacement.

A swinging, two-position cover protects wiring from inadvertent contact, as does the dead-front design. The two positions of the cover offer the option of more space to accommodate larger wire. The module cover provides a touch-sensitive pad; touch the pad and the groov EPIC processor displays information about the module, including specifications and a wiring diagram.

The module pivots into place and is held securely in place by a captive retention screw.

groov I/O modules are hot swappable (which means they can be installed or removed without turning off the unit or stopping the process) and self-identifying—as soon as you mount the module to the chassis, it communicates to the processor and identifies itself.

Each groov I/O module cover provides a large module LED to indicate module health at a glance.

All groov power supplies, voltage converters, adapters, and processors, are UL/cUL listed and compliant with the ATEX, Low Voltage, and EMC CE directives. Each module is factory tested twice before shipment and most modules are guaranteed for life.



Part Number

Part	Description
GRV-IMA-24	Analog current input, 24 channels, configurable input ranges of 4–20 mA, 0–20 mA, ± 20 mA

SPECIFICATIONS

Specification	GRV-IMA-24
Input Range (per channel)	-20 to +20 mA, 0 to 20 mA, 4 to 20 mA
Over-range Limits	-22 mA to +22 mA
Resolution	0.2 μ A (20 bits)
Accuracy	\pm 0.1% (\pm 20 μ A)
Input Voltage Drop nominal (Impedance \pm 20%)	5.5 V nominal @ 20 mA (275 Ohms)
Input Filter (hardware)	-3 dB at 140 Hz
Software Data Filtering: simple moving average (SMA) and Weighted Filter	SMA: 1 to 32 Readings Filter Weight: 1 to 4096
Step Input Response Time	277 ms x SMA value (8.8 s @ 32 SMA, Default SMA = 4)
Data Freshness / Update	277 ms
Analog Data Filtering	-3 dB @ 2.4 Hz / -25 dB @ 60 Hz
AC/DC Common Mode Rejection	> -120 dB
Max. Survivable Input	\pm 32 V
Max. Operating Common Mode Voltage	250 V
Problem Indications	out of range
Isolation (field-to-logic)	300 V working, 1500 V transient (1 minute)
Isolation (channel-to-channel)	300 V between zone A (ch 0-11) and zone B (ch 12-23)
Number of Channels	24
Chassis Power Consumption	1.0 W
Wire Size	28–14 AWG
Torque, connector screw	2.5 in-lb (0.28 N-m)
Torque, hold-down screw	3.5 in-lb (0.4 N-m)
Temperature (operating)	-20 °C to +70 °C
Temperature (storage)	-40 °C to +85 °C
Relative Humidity (non-condensing)	5–95%
Agency Approvals	UL/cUL (Class 1 Div. 2); CE, ATEX (Category 3, Zone 2), RoHS; DFARS; CB Scheme
Warranty	Lifetime

MOUNTING

Mount *groov* I/O modules onto a *groov* EPIC chassis. See [groov EPIC Chassis Data Sheet](#) (form 2247). You may also want to review the diagrams in the Description of Module Parts section so you learn the names of the various parts of the module.

Installing the module

The numbers on the diagrams correspond to the numbered steps in these instructions.

CAUTION: For electrical safety, turn off power to the chassis and de-energize field devices wired to the terminal connector before starting.

1. Orient the *groov* EPIC chassis so that the module connector numbers are right-side up, with module connector zero on the left, as shown in the diagram.
2. Hold the module at a 45° angle, lining up the alignment tab on the back tip of the module with the slot at the back of the chassis.
3. Pivot the front of the module down to the module connector on the chassis. Push to snap the module into the connector.
4. Swing the module cover up so you can access the module retention screw. Secure the module into position by tightening the module retention screw.

CAUTION: Do not over-tighten. See the torque specs in the Specifications table.

5. If the module does not have a terminal connector, install one.
6. Secure the terminal connector by tightening the terminal connector screw.

CAUTION: Do not over-tighten. See the torque specs in the Specifications table.

7. Follow the wiring instructions in the Pinout and Wiring section to wire your field devices to the channels on the terminal connector.
8. When wiring is complete, swing the module cover back down to cover the wires. If the wires are too thick to close the module cover easily, lift the module cover, then raise the back of the module cover up to the higher position. Swing the module cover back down to cover the wires.

When you are done installing modules and wiring, if you powered down your unit, you can turn it back on.

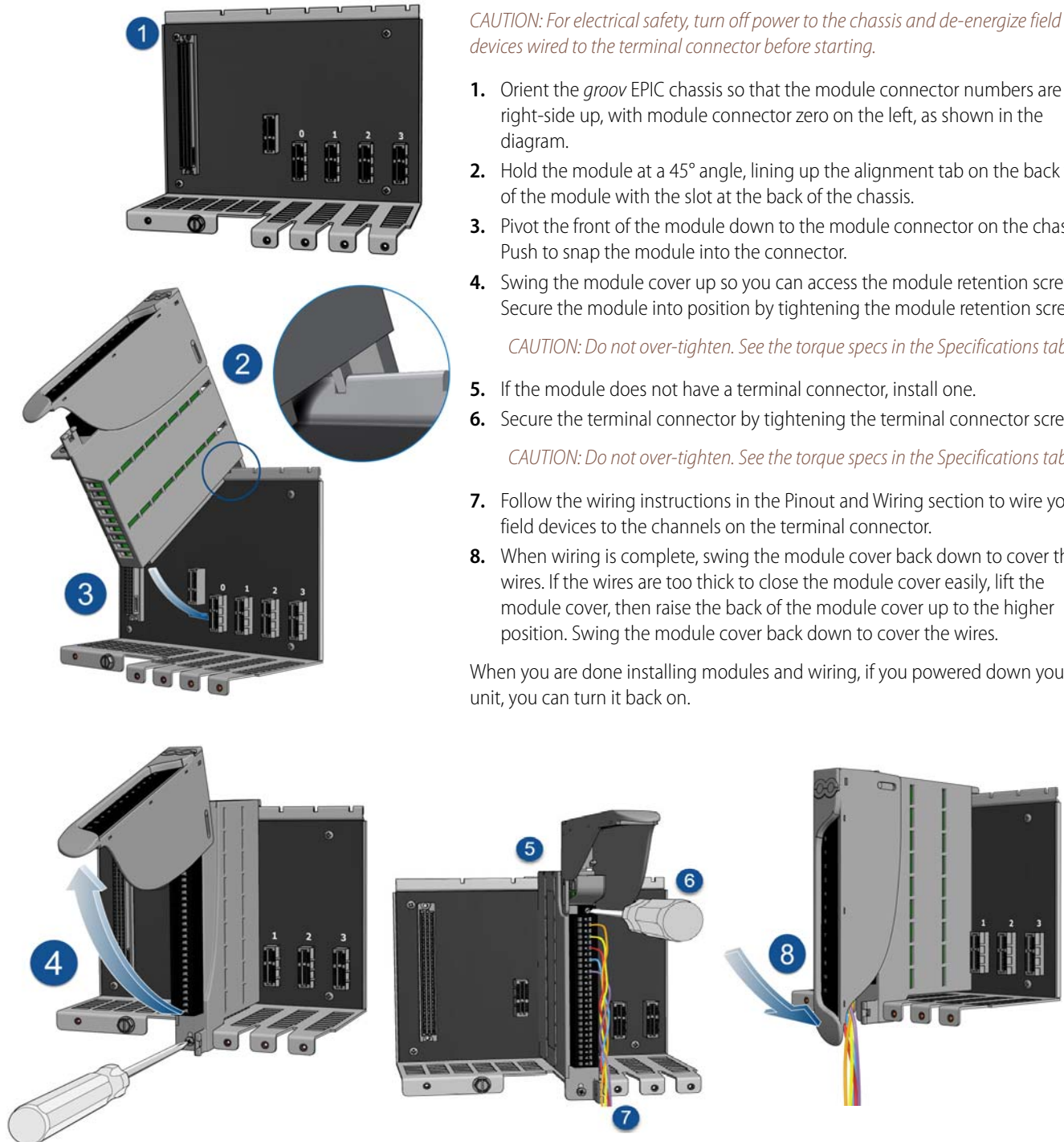

Removing the Module

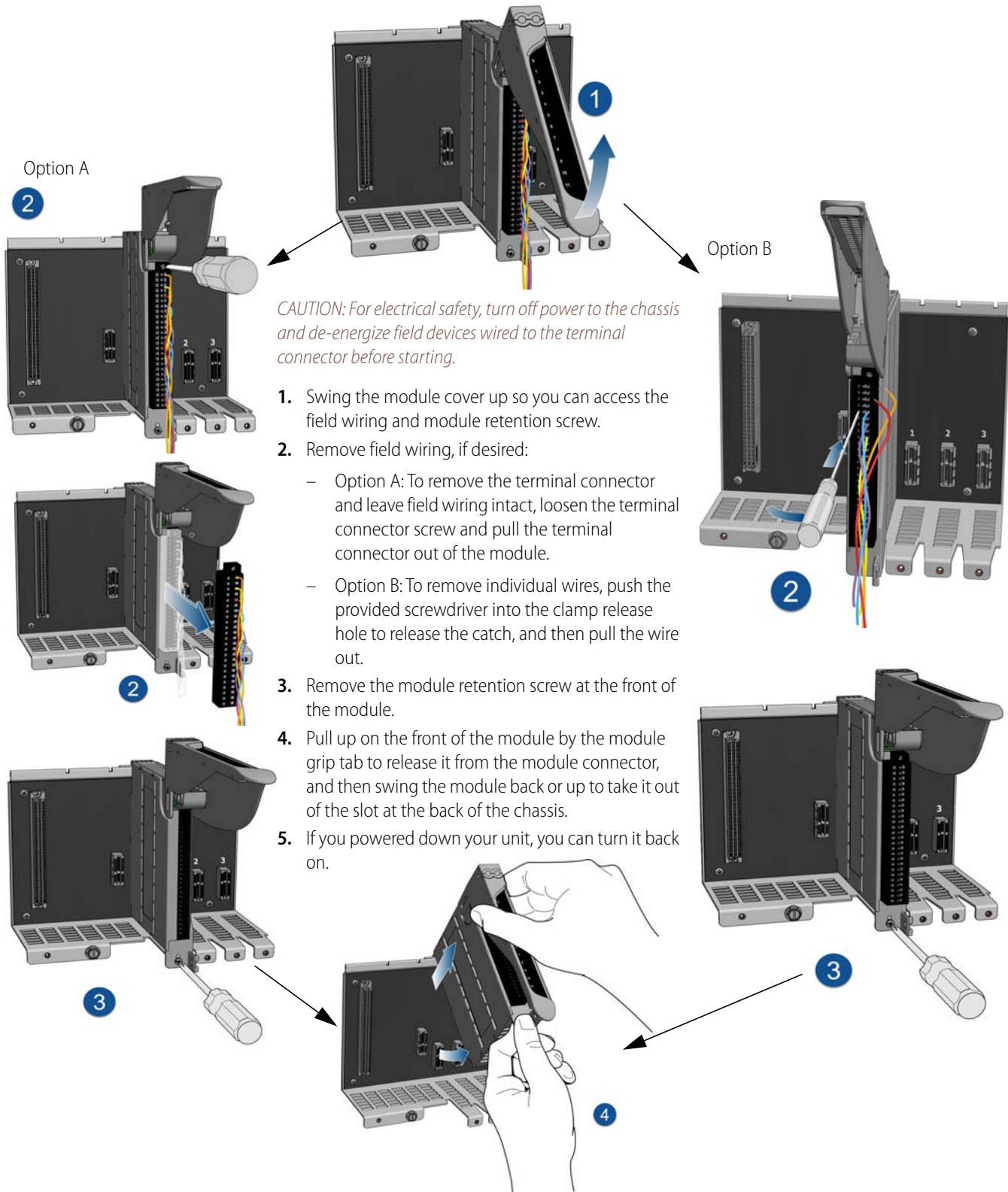

PINOUT AND WIRING

Before you begin wiring, do the following tasks:

CAUTION: For electrical safety, turn off power to the chassis and de-energize field devices wired to the terminal connector before starting.

- Select the appropriate wire. The terminal connectors are rated for 28–14 AWG wire. If you're using stranded wire, tin the strands for an easier, better connection.
- Ensure that you have the screwdriver supplied with your module.
- If you are unfamiliar with the names of some of the parts of the module, review the diagrams on this page and in the Description of Module Parts section.
- It may be easier to insert wires if you remove the terminal connector from the module. To remove the terminal connector, loosen the terminal connector screw at one end of the connector, then pull the connector straight out to remove it from the module.
- If you have never used a spring-clamp wiring system, take a moment to familiarize yourself with the diagram below. The clamp release hole is where you will insert the screwdriver. The field wiring hole is where you will insert your field wires.

If you look into the field wiring hole, you will see a highly reflective surface. If you can see that surface, that means that the clamp is closed.

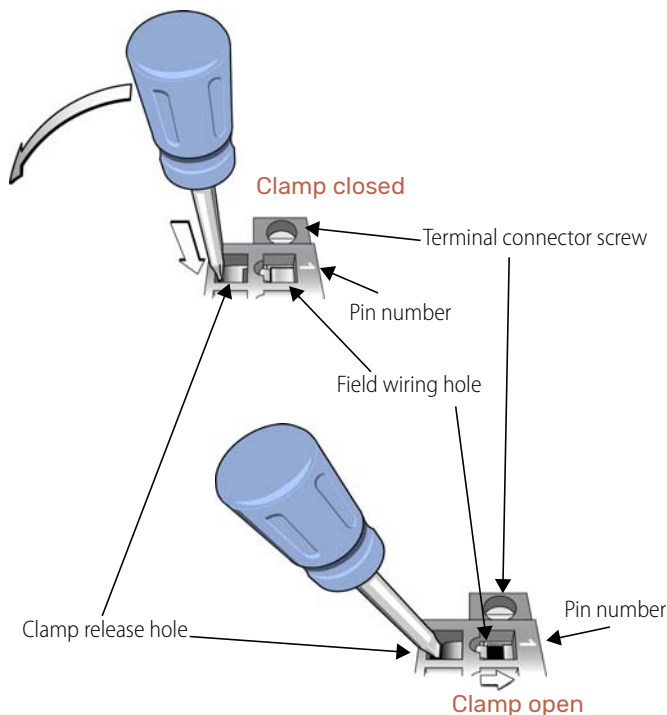

Follow these instructions to connect your field wires to the module:

CAUTION: For electrical safety, turn off power to the chassis and de-energize field devices wired to the terminal connector before starting.

1. Orient the module or terminal connector to match the wiring diagrams on the following page. To make it easier to handle the screwdriver and the field wires, secure the module by doing one of the following:
 - If you are working with the terminal connector while it is attached to the module, make sure the module is screwed securely to the chassis.
 - If you are working only with the terminal connector, secure the terminal connector with a clamp.
2. Hold the screwdriver so that you can place the flat side of the blade against the left side of the clamp release hole.
3. Slide the screwdriver into the clamp release hole, along the left side, until you feel the blade begin to meet some resistance. Gently push the screwdriver in a little more, until you feel the screwdriver stop.

Note: If you push in too hard, the screwdriver might pop out of the clamp release hole and you'll have to return to step 2.

- Look into the field wiring hole. If it is dark, the clamp is open. You can go to the next step.
 - If you can still see the highly reflective surface, gently pull the screwdriver handle to the left until you feel the blade stop. Hold the screwdriver in that position. Look into the field wiring hole. If it is dark, the clamp is open. You can go to the next step.
4. Insert the wire into the field wiring hole until it meets complete resistance. Then pull out the screwdriver.
 5. Test that the wire is secure by gently pulling on it. If the wire pulls out, repeat steps 2 through 4.

To remove a wire, push the screwdriver into the clamp release hole as described in steps 2 and 3 above, and then pull the wire out.

WIRING: GRV-IMA-24

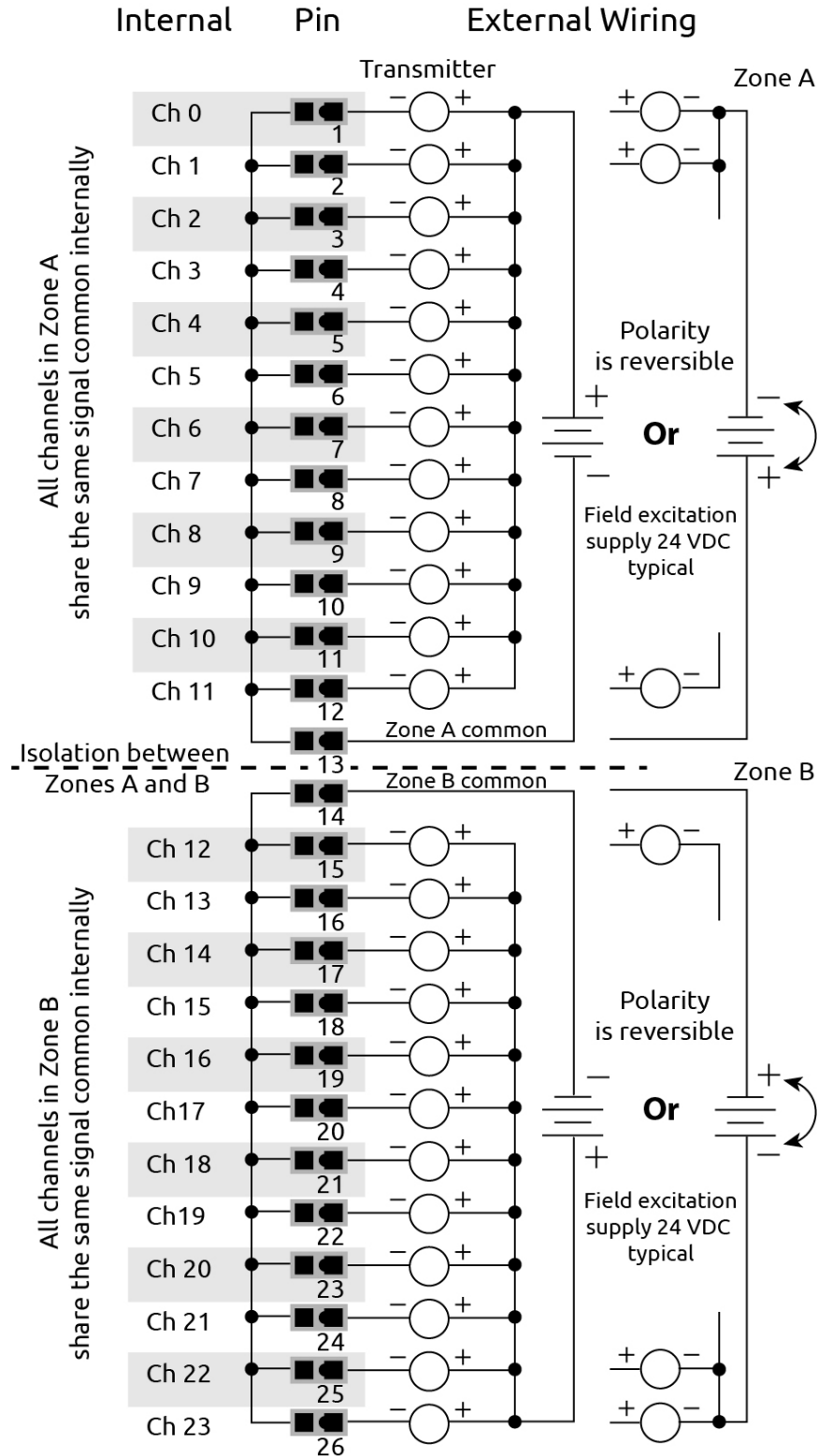

DIMENSIONS: GRV-IMA-24

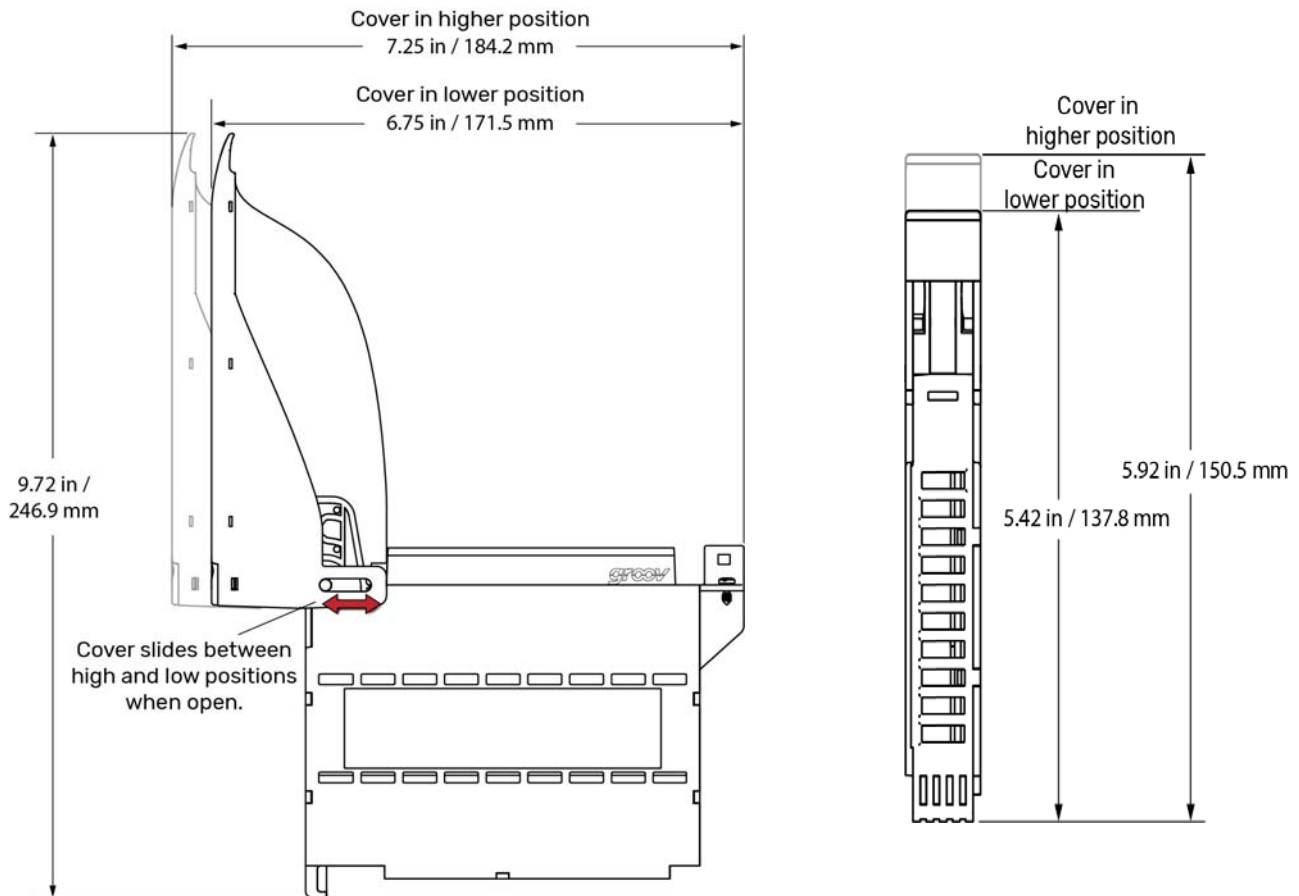

The module cover pivots and can be adjusted to two different heights (positions). The higher position provides more space to accommodate thicker wires.

To switch between higher and lower position, open the cover to at least a 45° angle. Grasp the hinged end of the module cover and do one of the following:

- Pull up on the back hinge to slide it to the higher position.
- Push down on the back hinge to slide it to the lower position.

You cannot switch between the higher and lower positions while the cover is closed.

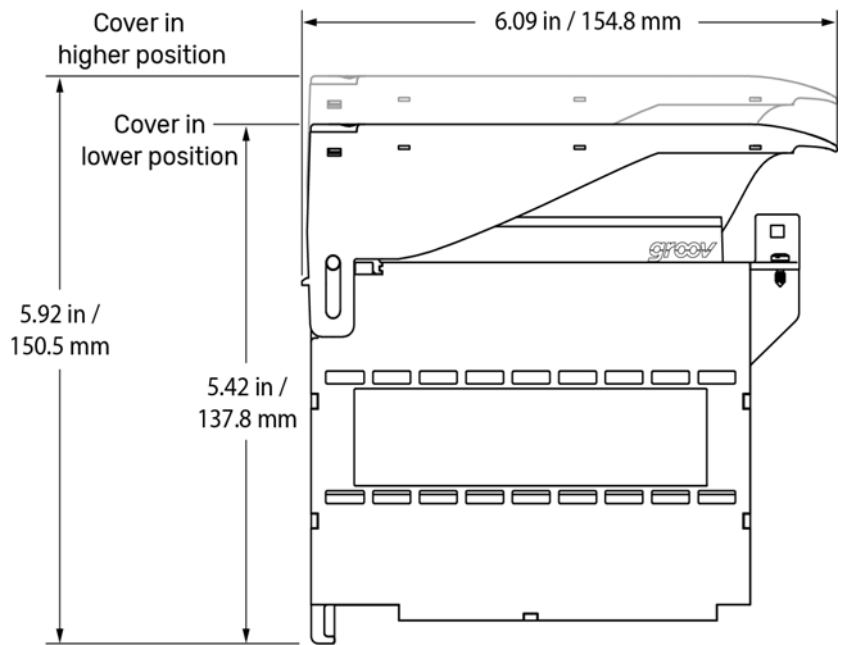

DIMENSIONS: GRV-IMA-24

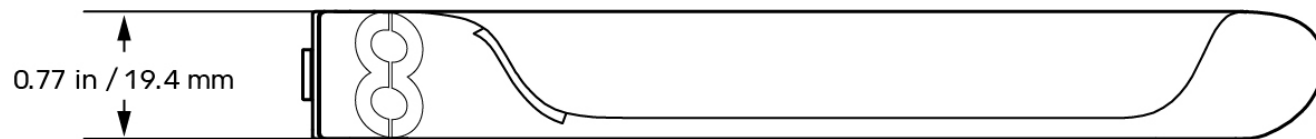

DESCRIPTION OF MODULE PARTS

The following diagram identifies the parts of the modules. The installation instructions in the documentation rely on these terms to describe how to handle the module.

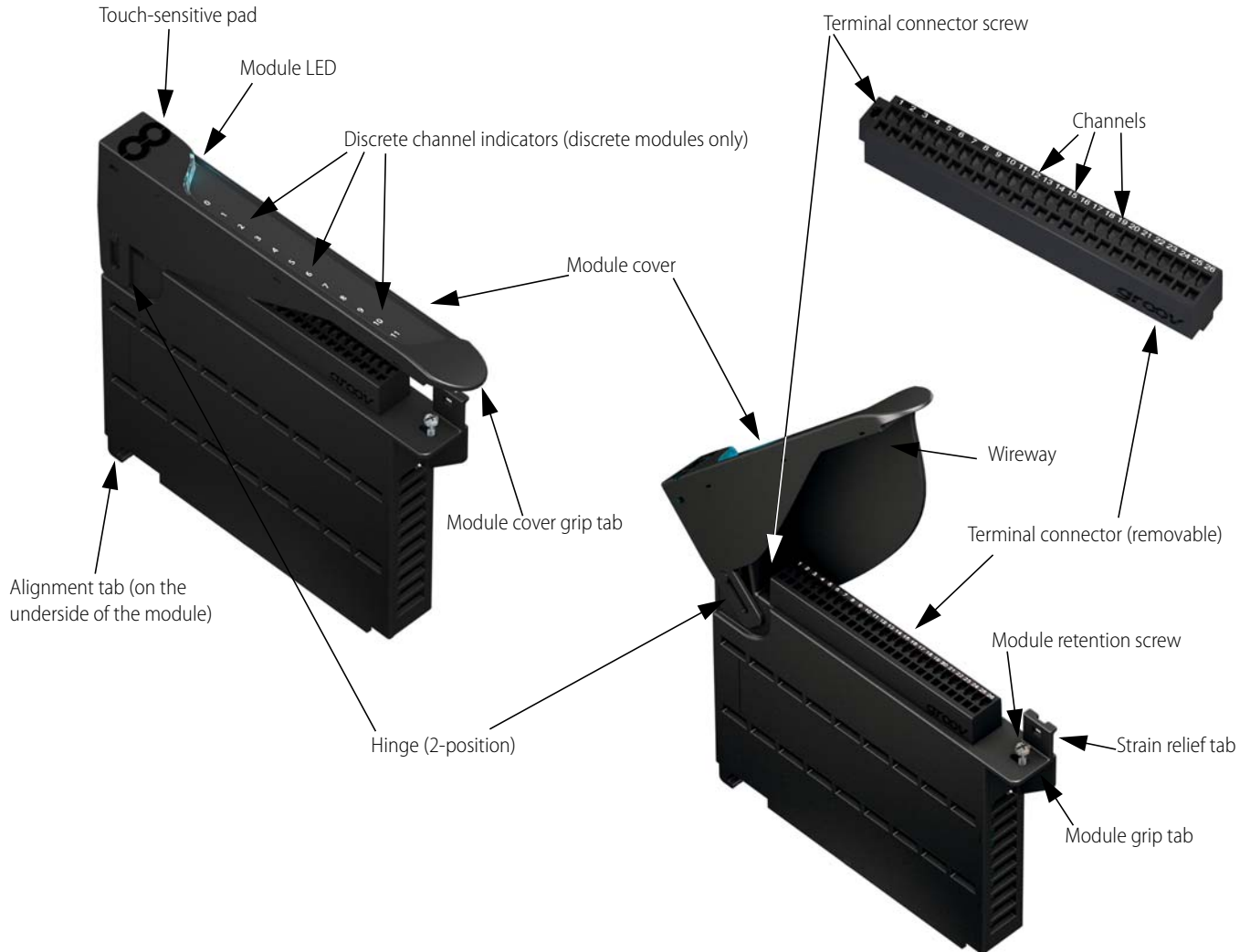

Some parts offer unique features:

- Module LED:** Provides a visual indication of the health of the module. For example, if it is blue, the module is operating normally. If it is blinking blue, the module's information is being displayed on the *groov* EPIC processor's screen. For a complete list of the various colors that this LED might display, see the *groov EPIC User's Guide* (form 2267).
- Terminal connector:** Specially designed for *groov* I/O modules, it provides a spring-clamp wiring system to securely connect the wires from your field devices to the module. To learn how to use a spring-clamp wiring system, see the Pinouts and Wiring section.
- Hinge and Wireway:** These two features work together to provide more space for wires. The hinge can be adjusted between a lower position and a higher position. The wireway is the space underneath the module cover. To increase this space, you can raise the hinge to the higher position.
- Discrete channel indicators:** Available only on discrete modules, the indicators are lit when the channel is on.
- Touch-sensitive pad:** Offers a convenient way to display the module's information on the *groov* EPIC processor. Press on the pad for approximately two seconds and the processor displays that module's information on the screen, as well as changing the module LED to a blinking blue light.