

# Uninterruptible power supply - QUINT4-UPS/24DC/24DC/10/EC - 2907070

Please be informed that the data shown in this PDF Document is generated from our Online Catalog. Please find the complete data in the user's documentation. Our General Terms of Use for Downloads are valid (<http://phoenixcontact.com/download>)



QUINT UPS with IQ Technology, RJ45 communication interfaces (EtherCAT<sup>®</sup>), for DIN rail mounting, input: 24 V DC, output: 24 V DC / 10 A, charging current: 3 A

## Product Description

The intelligent QUINT UPS for integration into established industrial networks: your systems continue to be supplied with uninterrupted power, even in the event of a mains failure. The battery management system with IQ Technology and a powerful battery charger ensures superior system availability.

## Why buy this product

- ✓ Easy integration into networks using PROFINET, EtherNet/IP, EtherCAT<sup>®</sup> and USB interfaces
- ✓ Evaluation of state of health (SOH) and state of charge (SOC), thanks to the intelligent battery management system (BMS)
- ✓ Automatic recognition of the battery capacities and technologies (VRLA-WTR, LI-ION)
- ✓ Monitoring of output current and voltage, as well as manual connection and disconnection of the system
- ✓ SFB Technology selectively trips standard miniature circuit breakers. Loads connected in parallel continue working.



## Key Commercial Data

Packing unit	1 STK
GTIN	 4 055626 171265
GTIN	4055626171265
Weight per Piece (excluding packing)	644.800 g
Custom tariff number	85371091
Country of origin	China

## Technical data

### Dimensions

Width	35 mm
Height	130 mm
Depth	125 mm
Width with alternative assembly	123 mm

# Uninterruptible power supply - QUINT4-UPS/24DC/24DC/10/EC - 2907070

## Technical data

### Dimensions

Height with alternative assembly	130 mm
Depth with alternative assembly	37 mm

### Ambient conditions

Degree of protection	IP20
Ambient temperature (operation)	-25 °C ... 70 °C (> 60 °C Derating: 2.5 %/K)
Ambient temperature (start-up type tested)	-40 °C
Ambient temperature (storage/transport)	-40 °C ... 85 °C
Max. permissible relative humidity (operation)	≤ 95 % (at 25 °C, non-condensing)
Climatic class	3K3 (EN 60721)
Degree of pollution	2
Installation height	≤ 4000 m

### Input data

Input voltage	24 V DC
Input voltage range	18 V DC ... 30 V DC
Electric strength, max.	35 V DC
Internal input fuse	no
Inrush surge current	≤ 7 A (≤ 4 ms)
Reverse polarity protection	yes
Fixed connect threshold	22 V DC
Switch-on time	max. 3 s
Voltage drop, input/output	0.4 V DC

### Output data (general)

Short-circuit-proof	yes
No-load proof	yes
Switch-over time	0 ms
UPS connection in parallel	no
UPS connection in series	no
Energy storage device connection in parallel	Yes, 5 (observe line protection)
Energy storage device connection in series	no
Efficiency	typ. 97 %

### Output data (mains operation)

Output voltage range	18 V DC ... 30 V DC
	18 V DC ... 32 V DC
Static Boost ( $I_{Stat.Boost}$ )	12.5 A
Dynamic Boost ( $I_{Dyn.Boost}$ )	20 A (5 s)
Selective Fuse Breaking ( $I_{SFB}$ )	60 A (15 ms)

### Output data (battery operation)

# Uninterruptible power supply - QUINT4-UPS/24DC/24DC/10/EC - 2907070

## Technical data

### Output data (battery operation)

Output voltage range	19 V DC ... 32 V DC
Static Boost ( $I_{Stat.Boost}$ )	12.5 A
Dynamic Boost ( $I_{Dyn.Boost}$ )	20 A (5 s)
Selective Fuse Breaking ( $I_{SFB}$ )	60 A (15 ms)

### Energy storage (battery)

Battery technology	VRLA, VRLA-WTR, LI-ION
End-of-charge voltage (temperature-compensated)	25 V DC ... 32 V DC
End-of-charge voltage	32 V DC
Max. capacity	80 Ah
Nominal capacity (without additional charger)	1.2 Ah ... 60 Ah
Charging current (configurable)	3 A
Charging time	120 h
Buffer time	25 min. (7.2 Ah)
Temperature compensation (configurable)	42 mV/K
Charge characteristic curve	IU <sub>0</sub> U
Deep discharge protection	19.2 V DC
Temperature sensor	yes
IQ-Technology	yes

### General data

Inflammability class in acc. with UL 94 (housing / terminal blocks)	V0
MTBF (IEC 61709, SN 29500)	> 1189000 h (25 °C)
	> 736900 h (40 °C)
	> 372700 h (60 °C)
Weight	0.5 kg
Environmental protection directive	RoHS
	WEEE
	Reach

### Connection data, input

Connection method	Screw connection
Conductor cross section solid min.	0.2 mm <sup>2</sup>
Conductor cross section solid max.	2.5 mm <sup>2</sup>
Conductor cross section flexible min.	0.2 mm <sup>2</sup>
Conductor cross section flexible max.	2.5 mm <sup>2</sup>
Single conductor/terminal point, stranded, with ferrule, min.	0.2 mm <sup>2</sup>
Single conductor/terminal point, stranded, with ferrule, max.	2.5 mm <sup>2</sup>
Conductor cross section AWG min.	30
Conductor cross section AWG max.	12
Stripping length	6.5 mm

# Uninterruptible power supply - QUINT4-UPS/24DC/24DC/10/EC - 2907070

## Technical data

### Connection data, input

Tightening torque, min	0.5 Nm
Tightening torque max	0.6 Nm

### Connection data, output

Connection method	Screw connection
Conductor cross section solid min.	0.2 mm <sup>2</sup>
Conductor cross section solid max.	2.5 mm <sup>2</sup>
Conductor cross section flexible min.	0.2 mm <sup>2</sup>
Conductor cross section flexible max.	2.5 mm <sup>2</sup>
Single conductor/terminal point, stranded, with ferrule, min.	0.2 mm <sup>2</sup>
Single conductor/terminal point, stranded, with ferrule, max.	2.5 mm <sup>2</sup>
Conductor cross section AWG min.	30
Conductor cross section AWG max.	12
Stripping length	6.5 mm
Tightening torque, min	0.5 Nm
Tightening torque max	0.6 Nm

### Connection data for battery

Connection method	Screw connection
Conductor cross section solid min.	0.2 mm <sup>2</sup>
Conductor cross section solid max.	2.5 mm <sup>2</sup>
Conductor cross section flexible min.	0.2 mm <sup>2</sup>
Conductor cross section flexible max.	2.5 mm <sup>2</sup>
Conductor cross section AWG min.	30
Conductor cross section AWG max.	12
Stripping length	6.5 mm
Tightening torque, min	0.5 Nm
Tightening torque max	0.6 Nm

## Standards and Regulations

Electromagnetic compatibility	Conformance with EMC Directive 2014/30/EU
Noise emission	Additional basic standard EN 61000-6-5 (immunity in power station), IEC/EN 61850-3 (energy supply)
Noise immunity	Immunity according to EN 61000-6-2 (industrial)
Standards/regulations	EN 61000-4-2
Contact discharge	4 kV (Test Level 2)
Standards/regulations	EN 61000-4-3
Frequency range	80 MHz ... 1 GHz
Test field strength	10 V/m (Test Level 3)
Frequency range	1.4 GHz ... 2 GHz
Test field strength	3 V/m (Test Level 2)

# Uninterruptible power supply - QUINT4-UPS/24DC/24DC/10/EC - 2907070

## Technical data

### Standards and Regulations

Standards/regulations	EN 61000-4-4
Comments	Criterion B
Standards/regulations	EN 61000-4-6
Frequency range	0.15 MHz ... 80 MHz
Voltage	10 V (Test Level 3)
Standards/regulations	EN 61000-4-8
Low Voltage Directive	Conformance with Low Voltage Directive 2014/35/EC
Standard – Safety extra-low voltage	IEC 61010-1 (SELV)
	IEC 61010-2-201 (PELV)
UL approvals	UL/C-UL Listed UL 61010-1
	UL/C-UL Listed UL 61010-2-201
	UL/C-UL Listed ANSI/ISA-12.12.01 Class I, Division 2, Groups A, B, C, D T4 (Hazardous Location)
Shock	18 ms, 30g, in each space direction (according to IEC 60068-2-27)
Vibration (operation)	2.3g
Overtoltage category (EN 61010-1)	II ( $\leq 4000$ m)

### Environmental Product Compliance

REACH SVHC	Lead 7439-92-1
------------	----------------

## Drawings

Block diagram

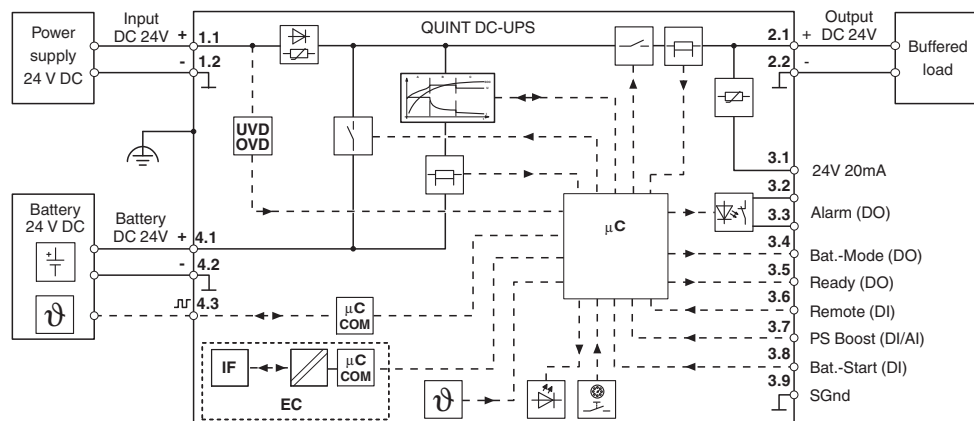

## Classifications

eCl@ss

eCl@ss 5.1	27242213
eCl@ss 8.0	27242209

# Uninterruptible power supply - QUINT4-UPS/24DC/24DC/10/EC - 2907070

## Classifications

### eCl@ss

eCl@ss 9.0	27040705
------------	----------

### ETIM

ETIM 5.0	EC000599
ETIM 6.0	EC000382

### UNSPSC

UNSPSC 13.2	39121004
-------------	----------

## Approvals

### Approvals

#### Approvals

UL Listed / cUL Listed / EAC / cULus Listed

#### Ex Approvals

UL Listed / cUL Listed / cULus Listed

## Approval details

UL Listed		<a href="http://database.ul.com/cgi-bin/XYV/template/LISEXT/1FRAME/index.htm">http://database.ul.com/cgi-bin/XYV/template/LISEXT/1FRAME/index.htm</a>	FILE E 123528
-----------	--	---	---------------

cUL Listed		<a href="http://database.ul.com/cgi-bin/XYV/template/LISEXT/1FRAME/index.htm">http://database.ul.com/cgi-bin/XYV/template/LISEXT/1FRAME/index.htm</a>	FILE E 123528
------------	--	---	---------------

EAC		RU C-DE.A*30.B.01082
-----	--	----------------------

cULus Listed		<a href="http://database.ul.com/cgi-bin/XYV/template/LISEXT/1FRAME/index.htm">http://database.ul.com/cgi-bin/XYV/template/LISEXT/1FRAME/index.htm</a>
--------------	--	---

## Accessories

### Accessories

## Uninterruptible power supply - QUINT4-UPS/24DC/24DC/10/EC - 2907070

### Accessories

#### Battery unit

Energy storage - UPS-BAT/VRLA/24DC/1.3AH - 2320296



Energy storage device, lead AGM, VRLA technology, 24 V DC, 1.3 Ah, tool-free battery replacement, automatic detection, and communication with QUINT UPS-IQ

---

Energy storage - UPS-BAT/VRLA/24DC/3.4AH - 2320306



Energy storage device, lead AGM, VRLA technology, 24 V DC, 3.4 Ah, tool-free battery replacement, automatic detection, and communication with QUINT UPS-IQ

---

Energy storage - UPS-BAT/VRLA/24DC/7.2AH - 2320319



Energy storage device, lead AGM, VRLA technology, 24 V DC, 7.2 Ah, tool-free battery replacement, automatic detection, and communication with QUINT UPS-IQ

---

Energy storage - UPS-BAT/VRLA/24DC/12AH - 2320322



Energy storage device, lead AGM, VRLA technology, 24 V DC, 12 Ah, tool-free battery replacement, automatic detection, and communication with QUINT UPS-IQ

---

Energy storage - UPS-BAT/VRLA/24DC/38AH - 2320335



Energy storage device, lead AGM, VRLA technology, 24 V DC, 38 Ah, automatic detection, and communication with QUINT UPS-IQ

---

## Uninterruptible power supply - QUINT4-UPS/24DC/24DC/10/EC - 2907070

### Accessories

Energy storage - UPS-BAT/VRLA-WTR/24DC/13AH - 2320416



Energy storage device, lead AGM, VRLA technology, 24 V DC, 13 Ah, tool-free battery replacement, automatic detection, and communication with QUINT UPS-IQ

---

Energy storage - UPS-BAT/VRLA-WTR/24DC/26AH - 2320429



Energy storage device, lead AGM, VRLA technology, 24 V DC, 26 Ah, tool-free battery replacement, automatic detection, and communication with QUINT UPS-IQ

---

Energy storage - UPS-BAT/LI-ION/24DC/120WH - 2320351



Energy storage device, LI-ION technology, 24 V DC, 120 Wh, for ambient temperatures of -20°C ... 60°C, automatic detection and communication with QUINT UPS-IQ

---

Energy storage - UPS-BAT/LI-ION/24DC/924WH - 2908232



Energy storage device, LI-ION technology, 24 V DC, 924 Wh, for ambient temperatures of -25 °C ... 60 °C, automatic detection and communication with QUINT UPS-IQ

---