

NOTE



All numerical values are in metric units [with U.S. customary units in brackets]. Dimensions are in millimeters [and inches]. Unless otherwise specified, dimensions have a tolerance of ± 0.13 [± 0.005] and angles have a tolerance of $\pm 2^\circ$. Figures and illustrations are for identification only and are not drawn to scale.

1. INTRODUCTION

This specification covers the requirements for application of FASTON Flag Receptacles with the "F"-Crimp wire barrel feature. Receptacles are offered in designs fitting 187 Series and 250 Series tab widths, and are available in four mating end configurations. The 187 Series receptacles will mate with 0.50 mm [.020 in.] thick tabs, while the 250 Series mate with 0.81 mm [.032 in.] thick tabs. Choices are shown in Figure 1 and explained in Paragraph 3.2.

When corresponding with TE Connectivity Personnel, use the terminology provided in this specification to facilitate your inquiries for information. Basic terms and features of this product are provided in Figure 1.

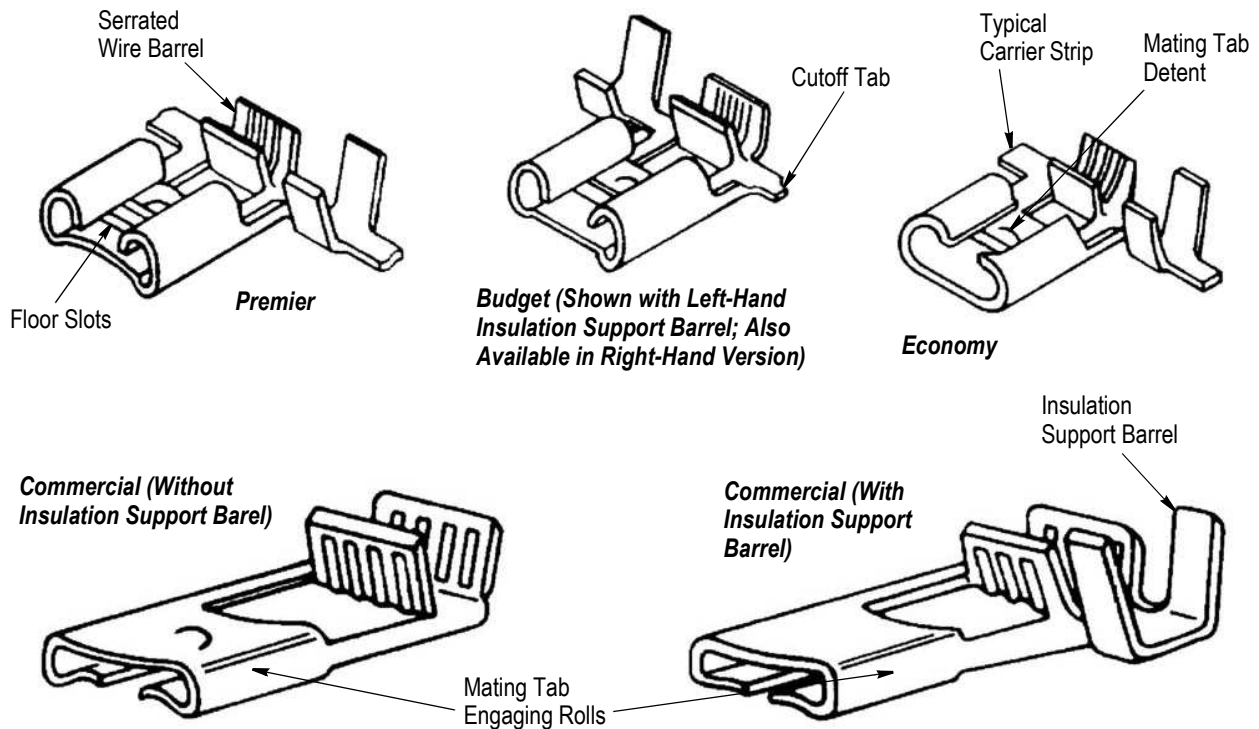

Figure 1

2. REFERENCE MATERIAL

- Updated document to corporate requirements
- Added new NOTE to Section 5, TOOLING

2.1. Customer Assistance

Reference Product Base Part Number 62813 and Product Code 1091 are representative of FASTON Flag Receptacles with "F"-Crimp Feature. Use of these numbers will identify the product line and help you to obtain product and tooling information. Such information can be obtained through a local Representative, by visiting our website at www.te.com, or by calling PRODUCT INFORMATION or the TOOLING ASSISTANCE CENTER at the numbers at the bottom of page 1.

2.2. Drawings

Customer Drawings for specific products are available from the service network. The information contained in Customer Drawings takes priority if there is a conflict with this specification or with any other technical documentation supplied by TE.

2.3. Specifications

The following application specifications provide information for the application of related FASTON products:

<u>Document Number</u>	<u>Document Title</u>
114-2028	FASTON 110 Series Flag Receptacles
114-2032	FASTON Reversible Flag Receptacles
114-2036	FASTON Straight Receptacles with "F"-Crimp Feature
114-2070	FASTON AMPLIVAR* Contact Tab
114-2078	FASTON Flag Receptacles with Tab Lok Feature
114-2082	FASTON Piggyback Receptacles
114-2126	FASTON "F"-Crimp Center-Strip Flag Receptacles

2.4. Instructional Material

The following list includes available instruction sheets (408-series) that provide assembly procedures for operation, maintenance and repair of tooling; and customer manuals (409-series) that provide setup, operation, and maintenance of machines.

<u>Document Number</u>	<u>Document Title</u>
408-1851	Hand Crimping Tools 90045 and 90162-1
408-3295	Preparing Reel of Contacts for Application Tooling
408-7424	Checking Terminal Crimp Height or Gaging Die Closure
408-8024	Miniature Quick-Change Applicator (End-Feed Type)
408-8039	Heavy Duty Miniature Quick-Change Applicators (End-Feed Type)
408-8053	Miniature Quick-Change Applicators
408-8059	General Preventive Maintenance for Applicators
408-9640	Crimp Quality Monitor Applicators for Side-Feed and End-Feed Applications
408-9816	Handling of Reeled Products
409-5128	Basic AMP-O-ELECTRIC* Model "K" Terminating Machines
409-5842	AMP-O-ELECTRIC Model "G" Terminating Machines 354500-[]
409-5852	AMPOMATOR* CLS III-G Lead Making Machine 122500-[]
409-5878	AMPOMATOR CLS IV+ Lead-making Machine 356500-[]
409-10016	Entry Level Terminator (ELT) Machine 1338600-[]
409-10027	Stripping Modules 1490500 and 1490502
409-10029	Stripping Modules 1490501 and 1490503

3. REQUIREMENTS

3.1. Storage

A. Ultraviolet Light

Prolonged exposure to ultraviolet light may deteriorate the chemical composition used in the receptacle materials.

B. Reeled Receptacles

When using reeled receptacles, store coil wound reels horizontally and traverse wound reels vertically.

C. Shelf Life

The receptacles should remain in the shipping containers until ready for use to prevent deformation to the receptacles. The receptacles should be used on a first in, first out basis to avoid storage contamination that could adversely affect signal transmissions.

D. Chemical Exposure

Do not store receptacles near any chemicals listed below, as they may cause stress corrosion cracking in the receptacles.

Alkalies Ammonia Citrates Phosphates Citrates Sulfur Compounds
 Amines Carbonates Nitrites Sulfur Nitrites Tartrates

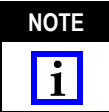

Where the above environmental conditions exist, phosphor-bronze receptacles are recommended if available.

3.2. Product Selection

The FASTON Flag Receptacles with “F”-Crimp feature are available in a variety of series sizes, types of mating ends, and thicknesses of tabs accepted, as described in Figure 2.

RECEPTACLE TYPE	RECEPTACLE THICKNESS AND TAB THICKNESS		
	250 SERIES x 0.81 [.032]		187 SERIES x 0.50 [.020] LEFT-HAND
	LEFT-HAND	RIGHT-HAND	
Premier with Insulation Support	X	X	---
Budget with Insulation Support	X	X	---
Economy with Insulation Support	X	---	---
Commercial with Insulation Support	X	---	---
Commercial without Insulation Support	X	---	X

Figure 2

Premier - Resilient rolls and a double slotted floor allow maximum compliance toward mating tabs. Each receptacle is thermally stress-relieved to help resist the effects of overstressing, often caused by production situations. Premier receptacles also are further processed to clean and lubricate the surface prior to shipping.

Budget - Construction and characteristics are much the same as the Premier, but the Budget receptacles have only one floor slot, and do not receive special processing. The 250 Series Budget receptacles are also constructed of 0.40 mm [.016 in.]-thick material rather than the typical 0.46 mm [.018 in.].

Economy - Distinguishable by a large, flared lead-in and relatively low profile of the mating end rolls.

Commercial - Abbreviated roll construction conserves stock material. These receptacles have generally higher insertion forces and a somewhat lower tolerance for abuse, allowing use in applications where undisturbed connections over long periods of time are common.

3.3. Wire Selection and Preparation

This product line will accept wire sizes 0.4-5.0 mm² [22-10 AWG] with an insulation outside diameter range of 1.52-4.06 mm [.060-.160 in.]. Refer to the table in Figure 3 for a more specific listing of wire insulation ranges, categorized by wire criteria and available receptacle sizes and series.

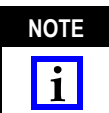

The applied crimp dimension (within the functional range of the product) is dependent on the termination tooling being used. Refer to the documentation (applicator logs and instruction sheets) supplied with the termination tooling for the applied crimp height. See Section 5, TOOLING.



DO NOT nick, scrape, or cut the wire conductor during the stripping operation.

NOTE: Not to Scale

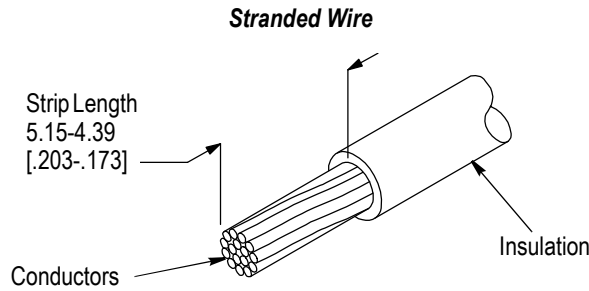

RECEPTACLE TYPE	RECEPTACLE WIRE INSULATION RANGE	RECEPTACLE WIRE RANGE mm ² [AWG]	WIRE APPLIED		WIRE BARREL CRIMP		INSULATION SUPPORT CRIMP WIDTH (REF)
			QUANTITY	SIZE	HEIGHT ±0.05 [±.002]	WIDTH (REF)	
250 SERIES WITH INSULATION SUPPORT							
Commercial	1.22-1.98 [.048-.078]	0.4-0.6 [22-20]	1	0.2 [24]	1.22 [.048]	1.77 [.070]	2.79 [.110]
			1	0.6 [20]	1.30 [.051]		
			1	0.8 [18]	1.37 [.054]		
	2.28-3.55 [.090-.140]	0.4-1.4 [22-16]	1	0.4 [22]	1.37 [.054]	1.52 [.060]	4.57 [.180]
			1	0.6 [20]	1.42 [.056]		
			1	0.8 [18]	1.52 [.060]		
1			1.4 [16]	1.70 [.067]			
Premier, Budget, Economy, Commercial	2.28-3.55 [.090-.140] or 2.79-5.08 [.110-.200]	0.8-2.0 [18-14]	1	0.8 [18]	1.47 [.058]	2.79 [.110]	4.57 [.180]
			1	1.4 [16]	1.62 [.064]		
			1	2.0 [14]	1.85 [.073]		
Premier, Budget	1.52-2.54 [.060-.100]	0.4-0.8 [22-18]	1	0.4 [22]	1.17 [.046]	2.29 [.090]	4.57 [.180]
			1	0.6 [20]	1.24 [.049]		
			1	0.8 [18]	1.35 [.053]		
250 SERIES WITHOUT INSULATION SUPPORT							
Commercial	1.52-4.06 [.060-.160]	3.0-5.0 [12-10]	1	3.0 [12]	2.16 [.085]	3.94 [.155]	None
			1	5.0 [10]	2.57 [.101]		
			2	2.0 [14]	2.33 [.092]		
			2	3.0 [12]‡	2.84 [.112]		
187 SERIES							
Commercial	1.52-1.77 [.060-.070]	0.4-0.8 [22-18]	1	0.4 [22]	1.06 [.042]	1.77 [.070]	2.79 [.110]
			1	0.6 [20]	1.14 [.045]		
			1	0.8 [18]	1.27 [.050]		
	2.28-3.30 [.090-.130]	0.6-1.4 [20-16]	1	0.6 [20]	1.04 [.041]	2.28 [.090]	4.06 [.140]
			1	0.8 [18]	1.16 [.046]		
			1	1.4 [16]	1.34 [.053]		

NOTE: Tabled information refers to all receptacles according to size, series, and stock thickness, rather than according to type (Premier, Budget, etc.). ‡Stranded conductor only. Others stranded or solid connector.

Figure 3

3.4. Crimped Receptacle Requirements

The receptacle must be crimped onto the wire according to instructions packaged with applicable tooling. After crimping, the receptacle should appear as shown in Figure 4.

CAUTION The wire insulation must not be damaged during the crimping process.



A. Wire Barrel Crimp

The crimp applied to the wire portion of the receptacle is the most compressed area and is most critical in ensuring optimum electrical and mechanical performance of the crimped receptacle. The receptacle wire barrel crimp height must be within the dimension provided in Figure 3.

B. Effective Crimp Length

For optimum crimp effectiveness, the crimp must be within the area shown and must meet the crimp dimensions provided in Figure 3. Effective crimp length shall be defined as that portion of the wire barrel, excluding bellmouths), fully formed by the crimping tool. Instructions for adjusting, repairing, and inspecting tools are packaged with the tools. See Section 5, TOOLING.

C. Bellmouths

Front and rear bellmouths shall be evident and conform to the dimensions given in Figure 4.

D. Cutoff Tabs

The cutoff tab shall be cut to the dimensions shown in Figure 4.

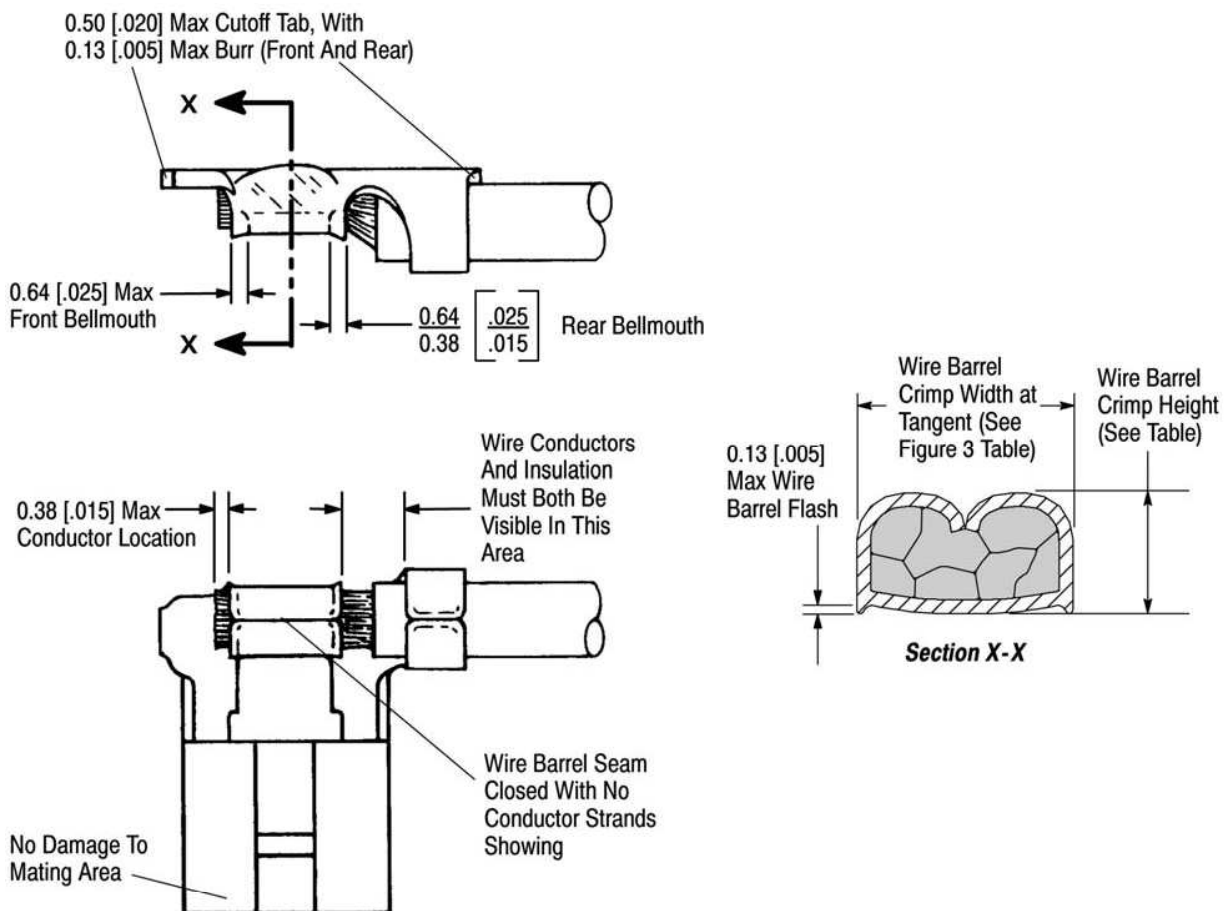

Figure 4

E. Burrs

The cutoff burr shall not exceed the dimensions shown in Figure 4.

F. Wire Barrel Flash

The wire barrel flash shall not exceed the dimensions shown in Figure 4, Section X-X.

G. Insulation Barrel Crimp

The insulation barrel shall grip the insulation firmly. A slight cut in the insulation by the insulation barrel is permissible as this causes no problems in actual use. Insulation crimp shall comply to width and height provided in Figure 3.

H. Wire Location

The wire conductor and insulation must be visible in the transition area between the wire and insulation barrels.

I. Conductor Extension

The conductor may extend beyond the wire barrel to the maximum shown.

J. Wire Barrel Seam

The wire barrel seam must be closed with no evidence of loose wire strands visible in the seam.

K. Twist and Roll

There shall be no twist, roll, deformation or other damage to the mating portion of the crimped receptacle that will impair usage of the receptacle. See Figure 4.

L. Straightness

The force applied during crimping may cause some slight bending between the crimped wire barrel and the mating portion of the receptacle. Such deformation is acceptable provided the bending has no effect on proper mating with the tab terminal.

NOTE

Periodic inspections must be made to ensure crimped receptacle formation is consistent as shown in figure 4.



3.5. Crimp Pull-Out Test

Crimped receptacles shall not be separated from their associated wires when subjected to forces as specified in the following table in Figure 5.

NOTE

Adjust tensile testing machine for head travel of 25.4 mm [1 inch] per minute. Directly and gradually apply force for 1 minute.



WIRE SIZE		MINIMUM FORCE	
mm ²	AWG	NEWTONS	POUNDS
0.4	22	36	8
0.6	20	58	13
0.8	18	89	20
1.4	16	133	30
2.0	14	223	50
3.0	12	311	70
5.0	10	356	80

Figure 5

3.6. Mating Tab Dimensions

Figure 6 shows features and dimensional requirements for tab terminals intended for mating with FASTON Receptacles.

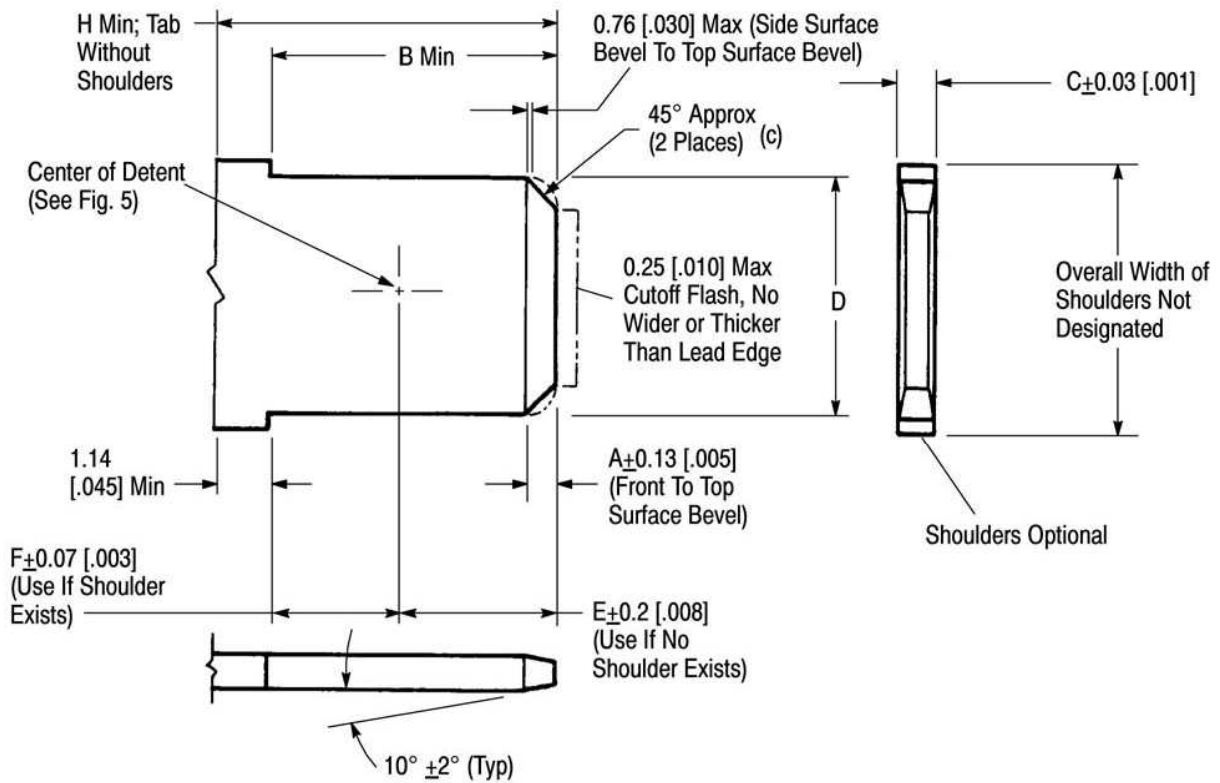

TAB SIZE (NOMINAL)	DIMENSIONS							
	A	B	C	D	E	F	G	H
6.35 x 0.81 [.250 x .032] W/Dimple	0.89 [.035]	7.80 [.307]	0.81 [.032]	6.35 [.250]	3.86 [.152]	4.06 [.160]	1.27 [.050]	8.94 [.352]
6.35 x 0.81 [.250 x .032] W/Hole	0.89 [.035]	7.80 [.307]	0.81 [.032]	6.35 [.250]	4.52 [.178]	3.40 [.134]	1.27 [.050]	8.94 [.352]
4.75 x 0.50 [.187 x .020] W/Dimple	0.76 [.030]	6.22 [.245]	0.50 [.020]	4.75 [.187]	2.54 [.100]	3.81 [.150]	1.14 [.045]	7.36 [.290]
4.75 x 0.50 [.187 x .020] W/Hole	0.76 [.030]	6.22 [.245]	0.50 [.020]	4.75 [.187]	3.18 [.125]	3.18 [.125]	1.14 [.045]	7.36 [.290]

NOTE: (c) Bevel need not be a straight line if within confines shown, or a radius of $G \pm 0.50$ mm [± 0.020 in.] may be substituted.

(d) Tab shall be flat ($0.3 \text{ mm}^2/\text{mm}^2$ [.001 inch/inch]); and free from burrs greater than 10% of tab thickness, or raised plateaus except as noted in Paragraph 3.8.

(e) Dimensional measurements shall not include plating, burrs, or flatness tolerance.

Figure 6

3.7. Tab Retention and Detent Configurations

A tab configuration having no locking feature may be used for applications where low mating retention forces are desirable. Where higher forces are sought, a tab with a detent meeting the requirements of Figure 7 should be used. Hole detents provide the greatest retention forces, while dimples provide acceptable medium-range forces.

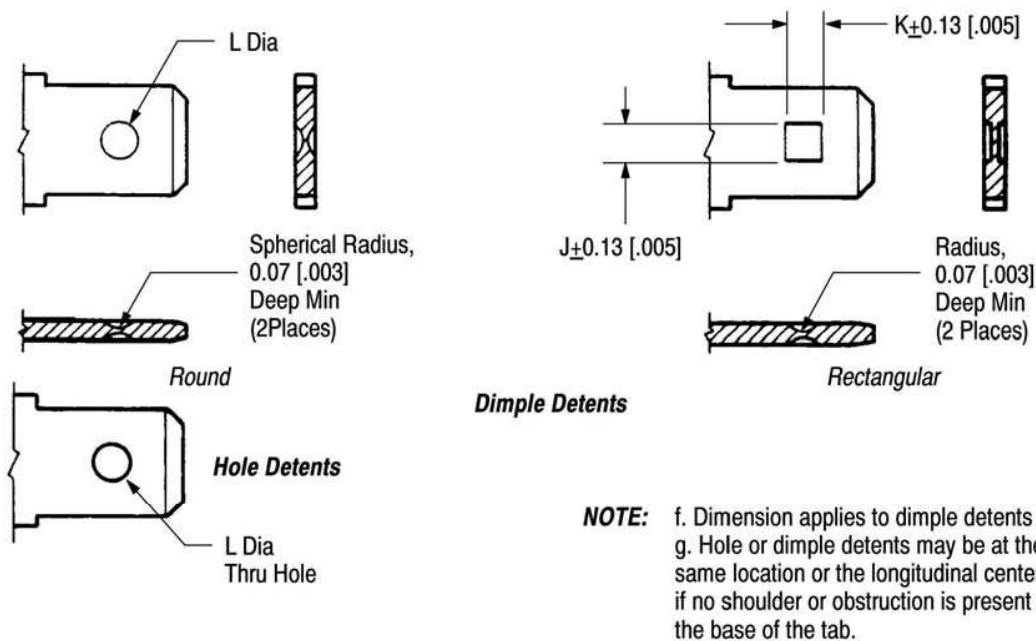

TAB WIDTH (NOMINAL)	J(f)	K(f)	L
6.35 [.250]	2.36 [.093]	1.91 [.075]	1.77 ±0.25/-0.13 [.070 ±.010/-0.005]
4.75 [.187]	1.57 [.062]	1.37 [.054]	1.40 ±0.13 [.055 ±.005]

Figure 7

3.8. Mating Overcycle and Testing

The forces required to mate and unmate a test mating tab and receptacle shall be as specified in Figure 8. Measure the force using a testing device capable of holding the reading. It must also provide accurate alignment with slow and steady mating and unmating of the test tab and receptacle.

NOTE

Testing may be done using a gage as described in Residential Controls--Quick-Connect Terminals, ANSI/NEMA No. DC2-1982. Test tabs shall be dimensioned as shown in Figures 7 and 8, except that the "C" dimension shall have a tolerance of ±0.007 mm [±.0003 in.] for brass tabs (±0.013 mm [±.0005 in.] for steel) and raised plateaus around detents shall be limited to a total of 0.025 mm [0.001 in.] for both sides.

TAB SIZE	FORCE (NEWTONS [POUNDS])				
	FIRST MATING (MAXIMUM) INDIVIDUAL	FIRST UNMATING (MINIMUM)		SIXTH UNMATING (MINIMUM)	
		AVERAGE	INDIVIDUAL	AVERAGE	INDIVIDUAL
TEST TAB AND UNPLATED RECEPTACLE					
6.35 [.250]	80 [18]	27 [6]	18 [4]	22 [5]	18 [4]
4.75 [.187]	67 [15]	22 [5]	13 [3]	13 [3]	9 [2]
TEST TAB AND TIN-PLATED RECEPTACLE					
6.35 [.250]	76 [17]	22 [5]	13 [3]	18 [4]	13 [3]
4.75 [.187]	67 [15]	22 [5]	13 [3]	13 [3]	9 [2]

Figure 8

3.9. Repair/Replacement

CAUTION

Damaged receptacles must not be used. If a damaged receptacle is evident, it must be cut from the wire and replaced with a new one.

4. QUALIFICATIONS

FASTON Flag Receptacles with "F"-Crimp Features meet Underwriters Laboratories (UL) 310 specification for quick-connect terminals, and are Listed in UL Component Listing Program-Electrical File No. E-66717. These products are also Certified in Files No. LR-49710 and LR-36371-4 of CSA International and also meet NEMA DC-2 mechanical requirements standard for quick-connect terminals.

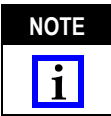

UL does not qualify this type of terminal when designed for application to 0.2 mm² [24 AWG] or smaller wire.

5. TOOLING

This section provides a selection of tools for various application requirements. Modified designs and additional tooling concepts may be available to meet other application requirements. A list of tooling recommendations and instructional material packaged with the tooling covering the full wire size range is provided in Figure 9.

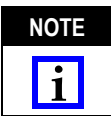

Tool Engineers have designed machines for a variety of application requirements. For assistance in setting up prototype and production line equipment, contact Tool Engineering through your local TE Representative or call the Tooling Assistance Center number at the bottom of page 1.



Tool life may be significantly reduced when crimping comparable steel/nickel plated steel terminals.

- **Applicators**

Applicators are designed for the full wire size range of strip-fed, precision formed receptacles, and provide for high volume, heavy duty production requirements. The applicators can be used in bench or floor model power units.

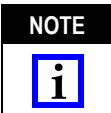

Each applicator is shipped with a metal identification tag attached. DO NOT remove this tag or disregard the information on it. Also, a packet of associated paperwork is included in each applicator shipment. This information should be read before using the applicator; then it should be stored in a clean, dry area near the applicator for future reference. Some changes may have to be made to the applicators to run in all related power units. Contact the Tooling Assistance Center number at the bottom of page 1 for specific changes.

- **Power Units**

A power unit is an automatic or semi-automatic device used to assist in the application of a product. Power unit includes the power source used to supply the force or power to an applicator.

- **Hand Tools**

Hand crimping tools that accommodate the full wire range are designed for prototype and low-volume applications such as repair of damaged receptacles.

SERIES	WIRE SIZE RANGE, AWG	APPLICATOR (DOCUMENT)	POWER UNIT (DOCUMENT)	HAND TOOL (DOCUMENT)
250	22-18	466725-1 (408-8039)	122500-2, -3 (409-5852)	---
			356500-1, -2 (409-5878)	
		466725-2 (408-8039)	565435-5 (409-5128)	
			1338600-3, -4 (409-10016)	
	22-16	466529-1 (408-8024)	122500-2, -3 (409-5852)	
			356500-1, -2 (409-5878)	
		466529-2 (408-8024)	565435-5 (409-5128)	
			1338600-3, -4 (409-10016)	

Figure 9 (Cont'd)

SERIES	WIRE SIZE RANGE, AWG	APPLICATOR (DOCUMENT)	POWER UNIT (DOCUMENT)	HAND TOOL (DOCUMENT)
250	18-14	466678-1 (408-8039)	122500-2, -3 (409-5852)	---
			356500-1, -2 (409-5878)	
		466678-2 (408-8039)	565435-5 (409-5128)	
			1338600-3, -4 (409-10016)	
		567006-1 (408-8039)	122500-2, -3 (409-5852)	
			356500-1, -2 (409-5878)	
		567006-2 (408-8039)	565435-5 (409-5128)	
			1338600-3, -4 (409-10016)	
		567006-3 (408-8039)	354500-1, -9, -11 (409-5842)	
			1338600-1, -2, -5, -6 (409-10016)	
		567300-1 (408-8039)	122500-2, -3 (409-5852)	
			356500-1, -2 (409-5878)	
		567300-2 (408-8039)	565435-5 (409-5128)	
			1338600-3, -4 (409-10016)	
		680613-1 (408-8039)	122500-2, -3 (409-5852)	
			356500-1, -2 (409-5878)	
		680613-2 (408-8039)	565435-5 (409-5128)	
			1338600-3, -4 (409-10016)	
	686327-1 (408-8024)	122500-2, -3 (409-5852)	90045 (408-1851)	
		356500-1, -2 (409-5878)		
	686327-2 (408-8024)	565435-5 (409-5128)		
		1338600-3, -4 (409-10016)		
	12-10	565712-1 (---)	1-471273-3 (409-5128)	---
			354500-1, -9, -11 (409-5842)	
567768-1 (---)		1338600-1, -2, -5, -6 (409-10016)		
		565435-5 (409-5128)		
687060-4 (408-8024)	1338600-3, -4 (409-10016)			
	122500-2, -3 (409-5852)			
1385033-1 (408-8039)	356500-1, -2 (409-5878)			
	1385033-2 (408-8039)	565435-5 (409-5128)		
10		1338600-3, -4 (409-10016)		

Figure 9 (Cont'd)

SERIES	WIRE SIZE RANGE, AWG	APPLICATOR (DOCUMENT)	POWER UNIT (DOCUMENT)	HAND TOOL (DOCUMENT)
187	22-18	687801-2 (408-8024)	122500-2, -3 (409-5852)	---
			356500-1, -2 (409-5878)	
		687801-3 (408-8024)	565435-5 (409-5128)	
			1338600-3, -4 (409-10016)	
	22-16	680176-1 (408-8039)	122500-2, -3 (409-5852)	
			356500-1, -2 (409-5878)	
		680176-2 (408-8039)	565435-5 (409-5128)	
			1338600-3, -4 (409-10016)	
		686262-4 (408-8024)	122500-2, -3 (409-5852)	
			356500-1, -2 (409-5878)	
		686262-5 (408-8024)	565435-5 (409-5128)	
			1338600-3, -4 (409-10016)	

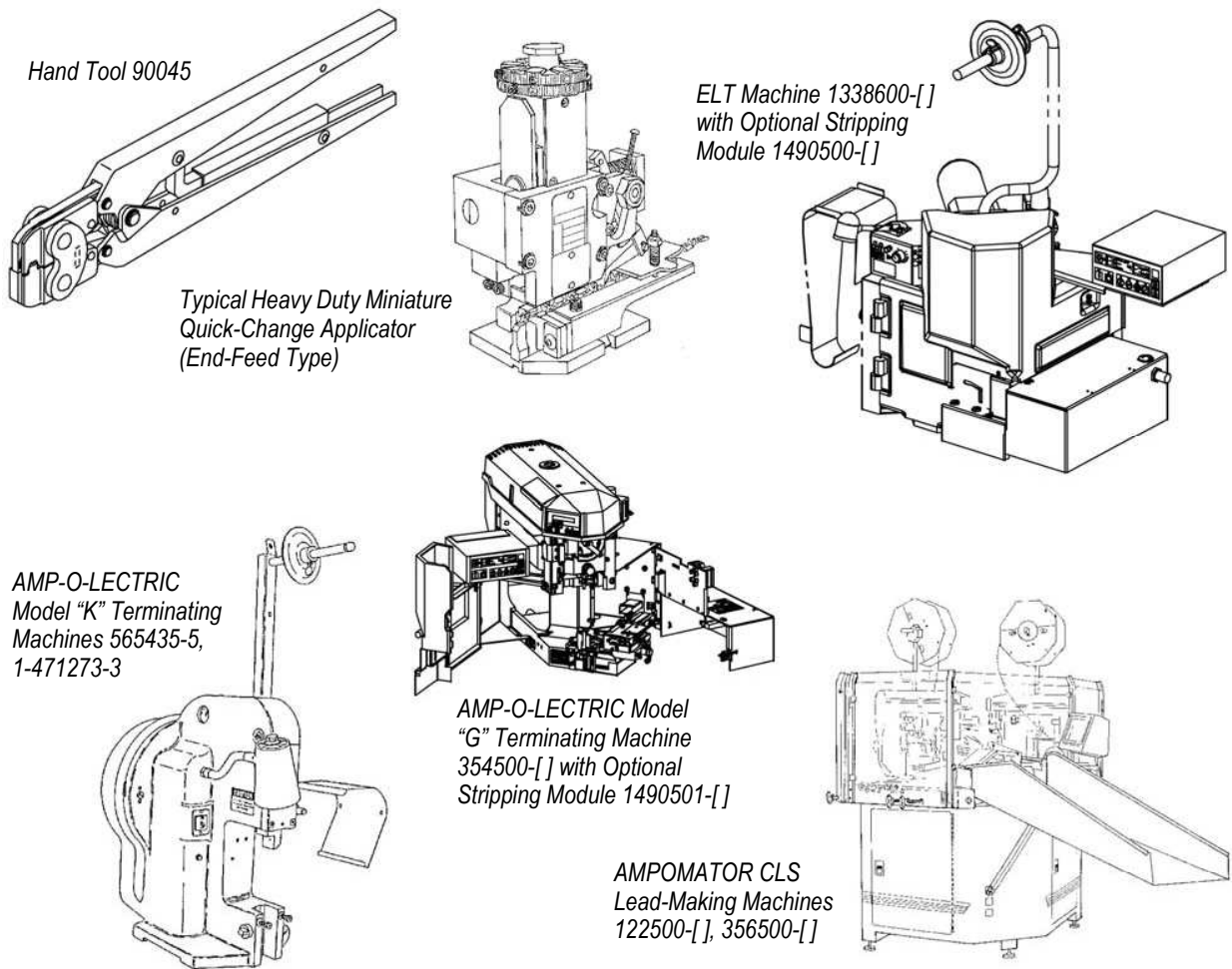

Figure 9 (End)

6. VISUAL AID

The illustration below shows a typical application of this product. This illustration should be used by production personnel to ensure a correctly applied product. Applications which DO NOT appear correct should be inspected using the information in the preceding pages of this specification and in the instructional material shipped with the product or tooling.

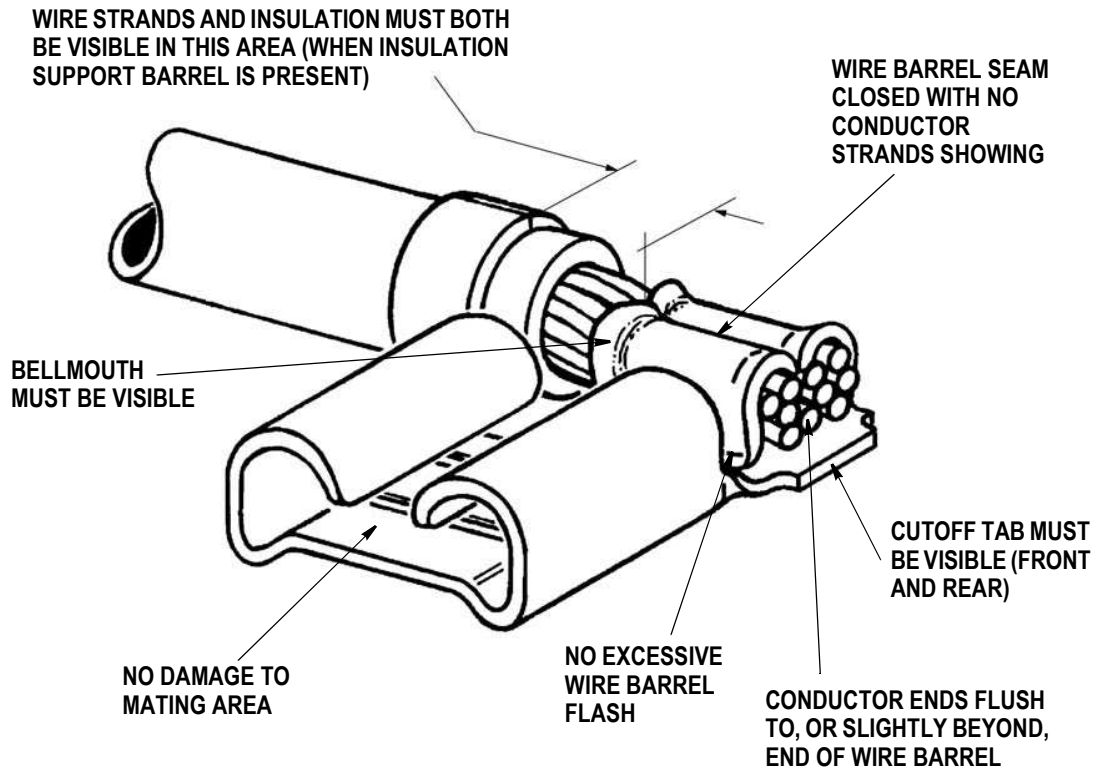

FIGURE 10. VISUAL AID