

# MAXM22510/MAXM22511 2.5kV<sub>RMS</sub> Complete Isolated RS-485/RS-422 Module Transceiver + Power

## General Description

The MAXM22510 and MAXM22511 isolated RS-485/RS-422, full-duplex, transceiver modules provide 2500V<sub>RMS</sub> (60s) of galvanic isolation between the cable-side (RS-485/RS-422 driver/receiver side) and the UART-side of the device. An integrated DC-DC powers the cable-side of the module. No external components are required.

Isolation improves communication by breaking ground loops and reduces noise when there are large differences in ground potential between ports. These devices allow for robust communication up to 500kbps (MAXM22510) and 25Mbps (MAXM22511).

The MAXM22510/MAXM22511 operate from a single 3.3V supply on the UART-side. An integrated DC-DC converter generates the 3.3V operating voltage for the cable-side of the module.

The devices include one drive channel and one receive channel. The receiver is 1/4-unit load, allowing up to 128 transceivers on a common bus.

Integrated true fail-safe circuitry ensures a logic-high on the receiver output when inputs are shorted or open. Undervoltage lockout disables the driver when cable-side or UART-side power supplies are below functional levels.

The driver outputs and receiver inputs are protected from  $\pm 35\text{kV}$  electrostatic discharge (ESD) to GNDB on the cable-side, as specified by the Human Body Model (HBM).

The MAXM22510/MAXM22511 are available in an LGA 44-pin package and operate over the  $-40^{\circ}\text{C}$  to  $+105^{\circ}\text{C}$  temperature range.

**Ordering Information** appears at end of data sheet.

## Benefits and Features

- Space Saving Solution
  - Fully Integrated Module for Compact Design
- High-Performance Transceiver Enables Flexible Designs
  - Integrated DC-DC for Cable-Side Power
  - Compliant with RS-485 EIA/TIA-485 Standard
  - 500kbps Maximum Data Rate for the MAXM22510
  - 25Mbps Maximum Data Rate for the MAXM22511
  - Allows Up to 128 Devices on the Bus
- Integrated Protection Ensures for Robust Communication
  - $\pm 35\text{kV}$  ESD (HBM) on Driver Outputs/Receiver Inputs
  - 2.5kV<sub>RMS</sub> Withstand Isolation Voltage for 60 Seconds ( $V_{ISO}$ )
  - 630V<sub>PEAK</sub> Maximum Repetitive Peak-Isolation Voltage ( $V_{IORM}$ )
  - 445V<sub>RMS</sub> Maximum Working-Isolation Voltage ( $V_{IOWM}$ )
  - Withstands  $\pm 10\text{kV}$  Surge per IEC 61000-4-5
  - Thermal Shutdown

## Safety Regulatory Approvals Pending

- UL According to UL1577
- cUL According to CSA Bulletin 5A

## Applications

- Industrial Automation
- Programmable Logic Controllers
- HVAC
- Power Meters
- Building Automation

## Functional Diagram

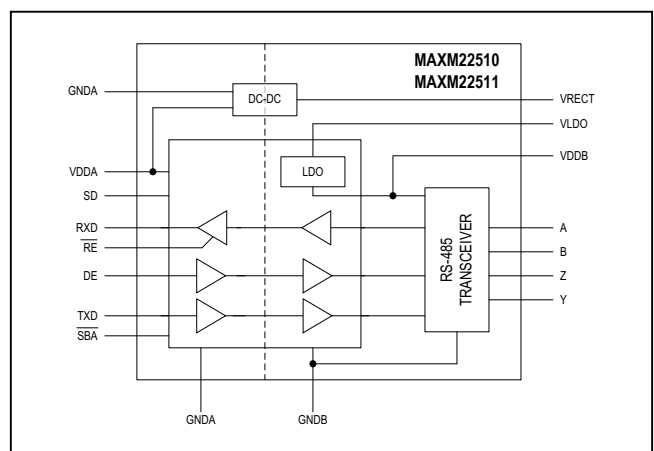

**Absolute Maximum Ratings**

V <sub>DDA</sub> to GNDA .....	-0.3V to +4V	Continuous Power Dissipation (T <sub>A</sub> = +70°C)
V <sub>DDB</sub> to GNDB .....	-0.3V to +6V	44-pin LGA (derate 28.6mW/°C above +70°C) .....
V <sub>RECT</sub> , V <sub>LDO</sub> to GNDB .....	-0.3V to +8V	Operating Temperature Range .....
SD, TXD, DE, $\overline{RE}$ to GNDA .....	-0.3V to +6V	Junction Temperature .....
S $\overline{BA}$ , RXD to GNDA .....	-0.3V to (V <sub>DDA</sub> + 0.3V)	Storage Temperature Range .....
A, B, Y, Z to GNDB .....	-8V to +13V	Soldering Temperature (reflow) .....
Short-Circuit Duration (RXD, $\overline{SBA}$ to GNDA, A, B, Y, Z, V <sub>DDB</sub> to GNDB) .....	Continuous	

Stresses beyond those listed under "Absolute Maximum Ratings" may cause permanent damage to the device. These are stress ratings only, and functional operation of the device at these or any other conditions beyond those indicated in the operational sections of the specifications is not implied. Exposure to absolute maximum rating conditions for extended periods may affect device reliability.

**Package Thermal Characteristics (Note 1)**

Junction-to-Ambient Thermal Resistance (θ <sub>JA</sub> ) .....	48.3°C/W	Junction-to-Case Thermal Resistance (θ <sub>JC</sub> ) (top) .....	39.2°C/W
---	----------	--	----------

**Note 1:** Package thermal resistances were obtained using the method described in JEDEC specification JESD51-7, using a four-layer board. For detailed information on package thermal considerations, refer to [www.maximintegrated.com/thermal-tutorial](http://www.maximintegrated.com/thermal-tutorial).

**DC Electrical Characteristics**

(V<sub>DDA</sub> – V<sub>GNDA</sub> = 3.0V to 3.6V, T<sub>A</sub> = T<sub>MIN</sub> to T<sub>MAX</sub>, unless otherwise noted. Typical values are at V<sub>DDA</sub> – V<sub>GNDA</sub> = 3.3V, V<sub>GNDA</sub> = V<sub>GNDB</sub>, and T<sub>A</sub> = +25°C.) (Notes 2, 3)

PARAMETER	SYMBOL	CONDITIONS	MIN	TYP	MAX	UNITS
<b>POWER</b>						
Supply Voltage	V <sub>DDA</sub>		3.0		3.6	V
Supply Current	I <sub>DDA</sub>	V <sub>DDA</sub> = 3.3V, DE = high, $\overline{RE}$ = TXD = low, SD = low, RXD unconnected, no load		25	44	mA
Shutdown Supply Current	I <sub>SD</sub>	V <sub>DDA</sub> = 3.3V, SD = high		0.01	10	µA
Undervoltage Lockout Threshold	V <sub>UVLOA</sub>	V <sub>DDA</sub> rising	2.55	2.7	2.85	V
	V <sub>UVLOB</sub>	V <sub>DDB</sub> rising	2.55	2.7	2.85	
Undervoltage Lockout Threshold Hysteresis	V <sub>UVHYSTA</sub>			200		mV
	V <sub>UVHYSTB</sub>			200		
Unregulated DC-DC Output Voltage	V <sub>RECT</sub>	V <sub>DDA</sub> = 3.3V, DE = high, $\overline{RE}$ = TXD = low, SD = low, no load		6		V
<b>LDO</b>						
LDO Output Voltage	V <sub>DDB</sub>		3.0	3.3	3.6	V
LDO Current Limit				300		mA
Load Regulation		V <sub>LDO</sub> = 3.3V, I <sub>LOAD</sub> = -20mA to -40mA		0.19	1.7	mV/mA
Line Regulation		V <sub>LDO</sub> = 3.3V to 7.5V, I <sub>LOAD</sub> = -20mA		0.12		mV/V
Dropout Voltage		V <sub>LDO</sub> = 3.18V, I <sub>DDB</sub> = -120mA		100	180	mV
Load Capacitance		Nominal value (Note 4)	1		10	µF

**DC Electrical Characteristics (continued)**

( $V_{DDA} - V_{GNDA} = 3.0V$  to  $3.6V$ ,  $T_A = T_{MIN}$  to  $T_{MAX}$ , unless otherwise noted. Typical values are at  $V_{DDA} - V_{GNDA} = 3.3V$ ,  $V_{GNDA} = V_{GNDB}$ , and  $T_A = +25^\circ C$ .) (Notes 2, 3)

PARAMETER	SYMBOL	CONDITIONS	MIN	TYP	MAX	UNITS
<b>LOGIC INTERFACE (TXD, RXD, DE, <math>\overline{RE}</math>, SD, <math>\overline{SBA}</math>)</b>						
Input High Voltage	$V_{IH}$	$\overline{RE}$ , TXD, DE, SD to GNDA	0.7 x $V_{DDA}$			V
Input Low Voltage	$V_{IL}$	$\overline{RE}$ , TXD, DE, SD to GNDA			0.8	V
Input Hysteresis	$V_{HYS}$	$\overline{RE}$ , TXD, DE, SD to GNDA	220			mV
Input Capacitance	$C_{IN}$	$\overline{RE}$ , TXD, DE, SD, $f = 1MHz$	2			pF
Input Pullup Current	$I_{PU}$	TXD, SD	-10	-4.5	-1.5	$\mu A$
Input Pulldown Current	$I_{PD}$	DE, $\overline{RE}$	1.5	4.5	10	$\mu A$
$\overline{SBA}$ Pullup Resistance	$R_{SBA}$		3	5	8	k $\Omega$
Output Voltage High	$V_{OH}$	RXD to GNDA, $I_{OUT} = -4mA$	$V_{DDA}$ -0.4			V
Output Voltage Low	$V_{OL}$	RXD to GNDA, $I_{OUT} = 4mA$			0.40	V
		$\overline{SBA}$ to GNDA, $I_{OUT} = 4mA$			0.45	
Short-Circuit Output Pullup Current	$I_{SH\_PU}$	$0V \leq V_{RXD} \leq V_{DDA}$ , $(V_A - V_B) > -10mV$ , $\overline{RE} = low$	-42			mA
Short-Circuit Output Pulldown Current	$I_{SH\_PD}$	$0V \leq V_{RXD} \leq V_{DDA}$ , $(V_A - V_B) < -200mV$ , $\overline{RE} = low$			42	mA
		$0V \leq V_{\overline{SBA}} \leq V_{DDA}$ , $\overline{SBA}$ is asserted			60	
Three-State Output Current	$I_{OZ}$	$0V \leq V_{RXD} \leq V_{DDA}$ , $\overline{RE} = high$	-1		+1	$\mu A$
<b>DRIVER</b>						
Differential Driver Output	$ V_{OD} $	$R_L = 54\Omega$ , TXD = high or low, <a href="#">Figure 1a</a>	1.5			V
		$R_L = 100\Omega$ , TXD = high or low, <a href="#">Figure 1a</a>	2.0			
		$-7V \leq V_{CM} \leq +12V$ , <a href="#">Figure 1b</a>	1.5		5	
Change in Magnitude of Differential Driver Output Voltage	$\Delta V_{OD}$	$R_L = 100\Omega$ or $54\Omega$ , <a href="#">Figure 1a</a> (Note 5)			0.2	V
Driver Common-Mode Output Voltage	$V_{OC}$	$R_L = 100\Omega$ or $54\Omega$ , <a href="#">Figure 1a</a>	$V_{DDB}/2$		3	V
Change in Magnitude of Common-Mode Voltage	$\Delta V_{OC}$	$R_L = 100\Omega$ or $54\Omega$ , <a href="#">Figure 1a</a> (Note 5)			0.2	V

**DC Electrical Characteristics (continued)**

( $V_{DDA} - V_{GNDA} = 3.0V$  to  $3.6V$ ,  $T_A = T_{MIN}$  to  $T_{MAX}$ , unless otherwise noted. Typical values are at  $V_{DDA} - V_{GNDA} = 3.3V$ ,  $V_{GNDA} = V_{GNDB}$ , and  $T_A = +25^\circ C$ .) (Notes 2, 3)

PARAMETER	SYMBOL	CONDITIONS	MIN	TYP	MAX	UNITS
Driver Short-Circuit Output Current	$I_{OSD}$	$GNDB \leq V_{OUT} \leq +12V$ , output low (Note 6)	+30		+250	mA
		$-7V \leq V_{OUT} \leq V_{DDB}$ , output high (Note 6)	-250		-30	
Single-Ended Driver Output Voltage High	$V_{OH}$	Y and Z outputs, $I_{Y,Z} = -20mA$	2.2			V
Single-Ended Driver Output Voltage Low	$V_{OL}$	Y and Z outputs, $I_{Y,Z} = +20mA$			0.8	V
Differential Driver Output Capacitance	$C_{OD}$	$DE = \overline{RE} = \text{high}$ , $f = 4MHz$		12		pF
<b>RECEIVER</b>						
Input Current (A and B)	$I_A, I_B$	$DE = \text{low}$ , $V_{DDB} = GNDB$ or $3.6V$	$V_{IN} = +12V$		+250	$\mu A$
			$V_{IN} = -7V$	-200		
Receiver Differential Threshold Voltage	$V_{TH}$	$-7V \leq V_{CM} \leq +12V$	-200	-120	-10	mV
Receiver Input Hysteresis	$\Delta V_{TH}$	$V_{CM} = 0V$		20		mV
Receiver Input Resistance	$R_{IN}$	$-7V \leq V_{CM} \leq +12V$ , $DE = \text{low}$	48			k $\Omega$
Differential Input Capacitance	$C_{A,B}$	Measured between A and B, $DE = \overline{RE} = \text{low}$ , $f = 6MHz$		12		pF
<b>PROTECTION</b>						
Thermal Shutdown Threshold	$T_{SHDN}$	Temperature Rising		+160		$^\circ C$
Thermal Shutdown Hysteresis	$T_{HYST}$			15		$^\circ C$
ESD Protection (A, B, Y, Z Pins to GNDB)		Human Body Model		$\pm 35$		kV
		IEC 61000-4-2 Air Gap Discharge		$\pm 18$		
		IEC 61000-4-2 Contact Discharge		$\pm 8$		
ESD Protection (A, B, Y, Z Pins to GNDA)		Human Body Model		$\pm 6$		kV
		330pF capacitor from GNDB to GNDA		$\pm 20$		
ESD Protection (All Other Pins)		Human Body Model		$\pm 4$		kV

**Switching Electrical Characteristics (MAXM22510)**

(V<sub>DDB</sub> – V<sub>GND</sub> = 3.0V to 3.6V, T<sub>A</sub> = T<sub>MIN</sub> to T<sub>MAX</sub>, unless otherwise noted. Typical values are at V<sub>DDB</sub> – V<sub>GND</sub> = 3.3V, V<sub>GND</sub> = V<sub>GND</sub>B, and T<sub>A</sub> = +25°C.) (Note 4)

PARAMETER	SYMBOL	CONDITIONS	MIN	TYP	MAX	UNITS
<b>DYNAMIC</b>						
Common Mode Transient Immunity	CMTI	(Note 7)		35		kV/μs
Glitch Rejection		TXD, DE, RXD	10	17	29	ns
<b>DRIVER</b>						
Driver Propagation Delay	t <sub>DPLH</sub> , t <sub>DPHL</sub>	R <sub>L</sub> = 54Ω, C <sub>L</sub> = 50pF <a href="#">Figure 2</a> and <a href="#">Figure 3</a>			1040	ns
Differential Driver Output Skew  t <sub>DPLH</sub> - t <sub>DPHL</sub>	t <sub>DSKEW</sub>	R <sub>L</sub> = 54Ω, C <sub>L</sub> = 50pF, <a href="#">Figure 2</a> and <a href="#">Figure 3</a>			144	ns
Driver Differential Output Rise or Fall Time	t <sub>LH</sub> , t <sub>HL</sub>	R <sub>L</sub> = 54Ω, C <sub>L</sub> = 50pF, <a href="#">Figure 2</a> and <a href="#">Figure 3</a>			900	ns
Maximum Data Rate	DR <sub>MAX</sub>		500			kbps
Driver Enable to Output High	t <sub>DZH</sub>	R <sub>L</sub> = 110Ω, C <sub>L</sub> = 50pF, <a href="#">Figure 4</a>			2540	ns
Driver Enable to Output Low	t <sub>DZL</sub>	R <sub>L</sub> = 110Ω, C <sub>L</sub> = 50pF, <a href="#">Figure 5</a>			2540	ns
Driver Disable Time from Low	t <sub>DLZ</sub>	R <sub>L</sub> = 110Ω, C <sub>L</sub> = 50pF, <a href="#">Figure 5</a>			140	ns
Driver Disable Time from High	t <sub>DHZ</sub>	R <sub>L</sub> = 110Ω, C <sub>L</sub> = 50pF, <a href="#">Figure 4</a>			140	ns
<b>RECEIVER</b>						
Receiver Propagation Delay	t <sub>RPLH</sub> , t <sub>RPHL</sub>	C <sub>L</sub> = 15pF, <a href="#">Figure 6</a> and <a href="#">Figure 7</a> (Note 8)			240	ns
Receiver Output Skew  t <sub>RPLH</sub> - t <sub>RPHL</sub>	t <sub>RSKEW</sub>	C <sub>L</sub> = 15pF, <a href="#">Figure 6</a> and <a href="#">Figure 7</a> (Note 8)			34	ns
Maximum Data Rate	DR <sub>MAX</sub>		500			kbps
Receiver Enable to Output High	t <sub>RZH</sub>	R <sub>L</sub> = 1kΩ, C <sub>L</sub> = 15pF, S2 closed, <a href="#">Figure 8</a>			20	ns
Receiver Enable to Output Low	t <sub>RZL</sub>	R <sub>L</sub> = 1kΩ, C <sub>L</sub> = 15pF, S1 closed, <a href="#">Figure 8</a>			30	ns
Receiver Disable Time From Low	t <sub>RLZ</sub>	R <sub>L</sub> = 1kΩ, C <sub>L</sub> = 15pF, S1 closed, <a href="#">Figure 8</a>			20	ns
Receiver Disable Time From High	t <sub>RHZ</sub>	R <sub>L</sub> = 1kΩ, C <sub>L</sub> = 15pF, S2 closed, <a href="#">Figure 8</a>			20	ns
<b>POWER</b>						
V <sub>DDB</sub> Startup Delay After Shutdown		No load on V <sub>DDB</sub> , SD falling		165		μs
Time to Shutdown		SD rising		80		ns

**Switching Electrical Characteristics (MAXM22511)**

(V<sub>DDA</sub> – V<sub>GNDA</sub> = 3.0V to 3.6V, T<sub>A</sub> = T<sub>MIN</sub> to T<sub>MAX</sub>, unless otherwise noted. Typical values are at V<sub>DDA</sub> – V<sub>GNDA</sub> = 3.3V, V<sub>GNDA</sub> = V<sub>GNDB</sub>, and T<sub>A</sub> = +25°C.) (Note 4)

PARAMETER	SYMBOL	CONDITIONS	MIN	TYP	MAX	UNITS
<b>DYNAMIC</b>						
Common Mode Transient Immunity	CMTI	(Note 7)		35		kV/μs
Glitch Rejection		TXD, DE, RXD	10	17	29	ns
<b>DRIVER</b>						
Driver Propagation Delay	t <sub>DPLH</sub> , t <sub>DPHL</sub>	R <sub>L</sub> = 54Ω, C <sub>L</sub> = 50pF, <a href="#">Figure 2</a> and <a href="#">Figure 3</a>			65	ns
Differential Driver Output Skew  t <sub>DPLH</sub> - t <sub>DPHL</sub>	t <sub>DSKEW</sub>	R <sub>L</sub> = 54Ω, C <sub>L</sub> = 50pF, <a href="#">Figure 2</a> and <a href="#">Figure 3</a>			7	ns
Driver Differential Output Rise or Fall Time	t <sub>LH</sub> , t <sub>HL</sub>	R <sub>L</sub> = 54Ω, C <sub>L</sub> = 50pF, <a href="#">Figure 2</a> and <a href="#">Figure 3</a>			10	ns
Maximum Data Rate	DR <sub>MAX</sub>		25			Mbps
Driver Enable to Output High	t <sub>DZH</sub>	R <sub>L</sub> = 110Ω, C <sub>L</sub> = 50pF, <a href="#">Figure 4</a>			80	ns
Driver Enable to Output Low	t <sub>DZL</sub>	R <sub>L</sub> = 110Ω, C <sub>L</sub> = 50pF, <a href="#">Figure 5</a>			80	ns
Driver Disable Time from Low	t <sub>DLZ</sub>	R <sub>L</sub> = 110Ω, C <sub>L</sub> = 50pF, <a href="#">Figure 5</a>			80	ns
Driver Disable Time from High	t <sub>DHZ</sub>	R <sub>L</sub> = 110Ω, C <sub>L</sub> = 50pF, <a href="#">Figure 4</a>			80	ns
<b>RECEIVER</b>						
Receiver Propagation Delay	t <sub>RPLH</sub> , t <sub>RPHL</sub>	C <sub>L</sub> = 15pF, <a href="#">Figure 6</a> and <a href="#">Figure 7</a> (Note 8)			65	ns
Receiver Output Skew  t <sub>RPLH</sub> - t <sub>RPHL</sub>	t <sub>RSKEW</sub>	C <sub>L</sub> = 15pF, <a href="#">Figure 6</a> and <a href="#">Figure 7</a> (Note 8)			7	ns
Maximum Data Rate	DR <sub>MAX</sub>		25			Mbps
Receiver Enable to Output High	t <sub>RZH</sub>	R <sub>L</sub> = 1kΩ, C <sub>L</sub> = 15pF, S2 closed, <a href="#">Figure 8</a>			20	ns
Receiver Enable to Output Low	t <sub>RZL</sub>	R <sub>L</sub> = 1kΩ, C <sub>L</sub> = 15pF, S1 closed, <a href="#">Figure 8</a>			30	ns
Receiver Disable Time From Low	t <sub>RLZ</sub>	R <sub>L</sub> = 1kΩ, C <sub>L</sub> = 15pF, S1 closed, <a href="#">Figure 8</a>			20	ns
Receiver Disable Time From High	t <sub>RHZ</sub>	R <sub>L</sub> = 1kΩ, C <sub>L</sub> = 15pF, S2 closed, <a href="#">Figure 8</a>			20	ns
<b>POWER</b>						
V <sub>DDB</sub> Startup Delay After Shutdown		No load on V <sub>DDB</sub> , SD falling		165		μs
Time to Shutdown		SD rising		80		ns

**Note 2:** All devices are 100% production tested at T<sub>A</sub> = +25°C. Specifications over temperature are guaranteed by design and characterization.

**Note 3:** All currents into the device are positive. All currents out of the device are negative. All voltages are referenced to their respective ground (GNDA or GNDB), unless otherwise noted.

**Note 4:** Not production tested. Guaranteed by design and characterization.

**Note 5:** ΔV<sub>OD</sub> and ΔV<sub>OC</sub> are the changes in |V<sub>OD</sub>| and V<sub>OC</sub>, respectively, when the TXD input changes state.

**Note 6:** The short circuit output current applies to the peak current just prior to current limiting.

**Note 7:** CMTI is the maximum sustainable common-mode voltage slew rate while maintaining the correct output states. CMTI applies to both rising and falling common-mode voltage edges. Tested with the transient generator connected between GNDA and GNDB. V<sub>CM</sub> = 1kV.

**Note 8:** Capacitive load includes test probe and fixture capacitance.

## Insulation Characteristics

PARAMETER	SYMBOL	CONDITIONS	VALUE	UNITS
Partial Discharge Test Voltage	V <sub>PR</sub>	Method B1 = V <sub>IORM</sub> x 1.875 (t = 1s, partial discharge < 5pC) (Note 4)	1182	V <sub>P</sub>
Maximum Repetitive Peak Withstand Voltage	V <sub>IORM</sub>	(Note 9)	630	V <sub>P</sub>
Maximum Working Isolation Voltage	V <sub>IOWM</sub>	(Note 9)	445	V <sub>RMS</sub>
Maximum Transient Isolation Voltage	V <sub>IOTM</sub>		3600	V <sub>P</sub>
Maximum Withstand Isolation Voltage	V <sub>ISO</sub>	t = 60s, f = 60Hz (Notes 9,10)	2500	V <sub>RMS</sub>
Maximum Surge Isolation Voltage	V <sub>IOSM</sub>	IEC 61000-4-5, 1.2/50µs	10	kV
Insulation Resistance	R <sub>S</sub>	T <sub>A</sub> = +150°C, V <sub>IO</sub> = 500V	>10 <sup>9</sup>	Ω
Insulation Resistance	R <sub>IO</sub>	T <sub>A</sub> = +25°C, V <sub>IO</sub> = 500V	>10 <sup>12</sup>	Ω
Barrier Capacitance Input to Output	CIO		6	pF
Creepage Distance	CPG		8	mm
Clearance Distance	CLR		8	mm
Internal Clearance		Distance through insulation	0.015	mm
Comparative Tracking Resistance Index	CTI	Material Group II (IEC 60112)	550	
Climatic Category			40/125/21	
Pollution Degree (DIN VDE 0110, Table 1)			2	

**Note 9:** V<sub>IORM</sub>, V<sub>IOWM</sub>, and V<sub>ISO</sub> are defined by the IEC 60747-5-5 standard.

**Note 10:** Product is qualified at V<sub>ISO</sub> for 60 seconds. Not production tested.

## Safety Regulatory Approvals

<b>UL (Pending)</b>
The MAXM22510/MAXM22511 are certified under UL1577. Rate up to 2500V <sub>RMS</sub> isolation voltage for basic insulation.
<b>cUL (Pending)</b>
The MAXM22510/MAXM22511 are certified under UL1577. Rate up to 2500V <sub>RMS</sub> isolation voltage for basic insulation.

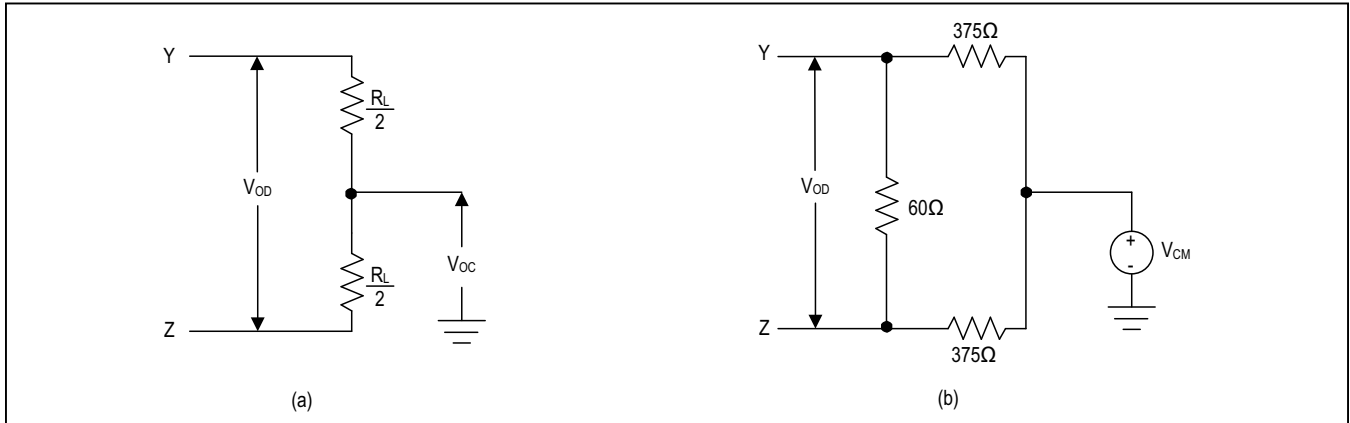

Figure 1. Driver DC Test Load

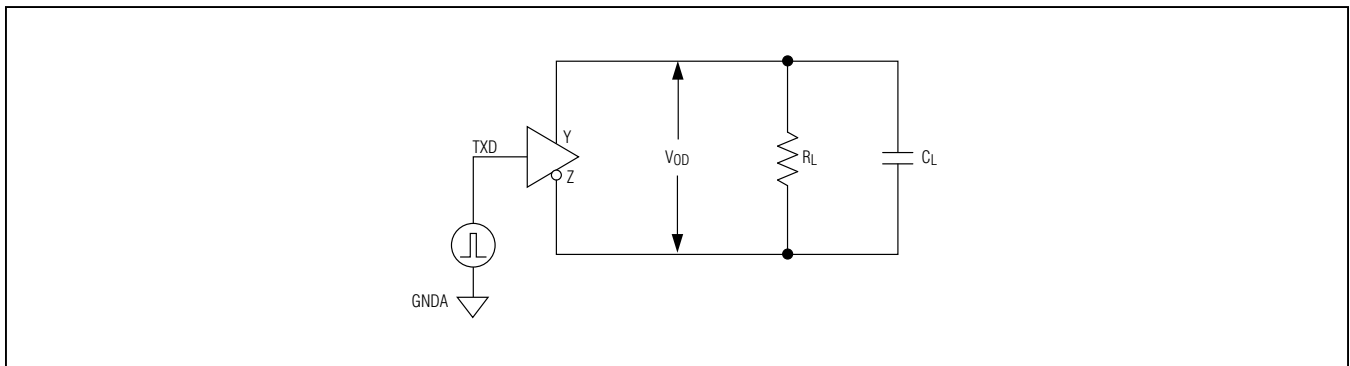

Figure 2. Driver Timing Test Circuit

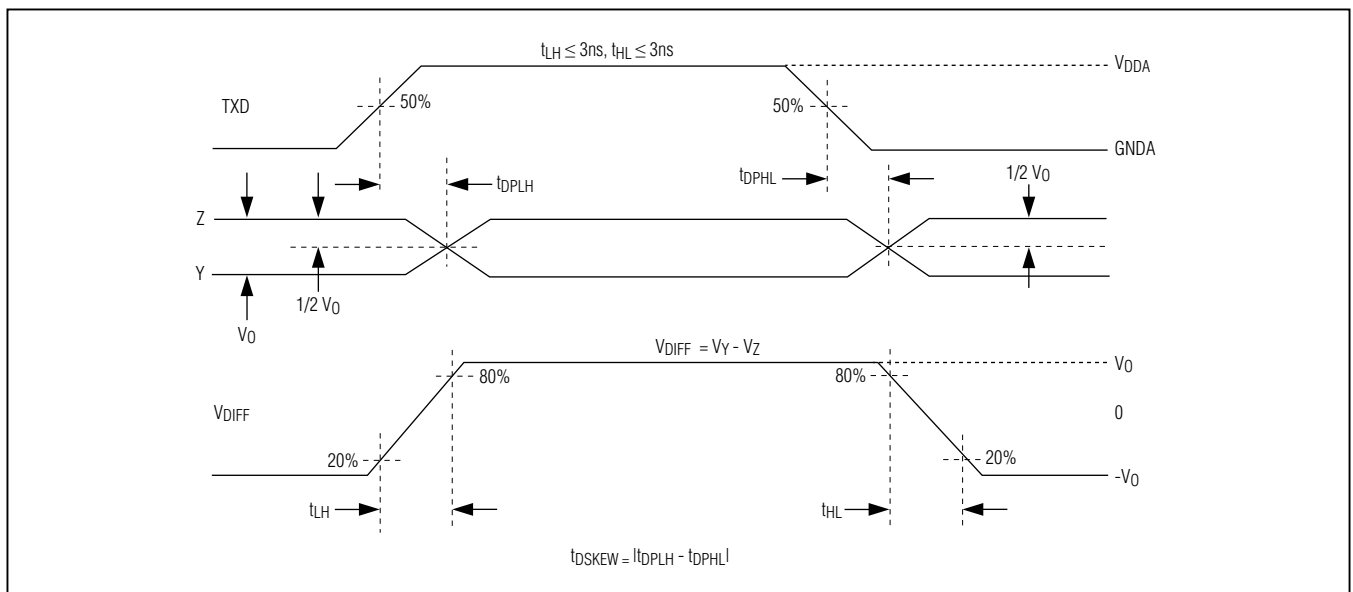

Figure 3. Driver Propagation Delays



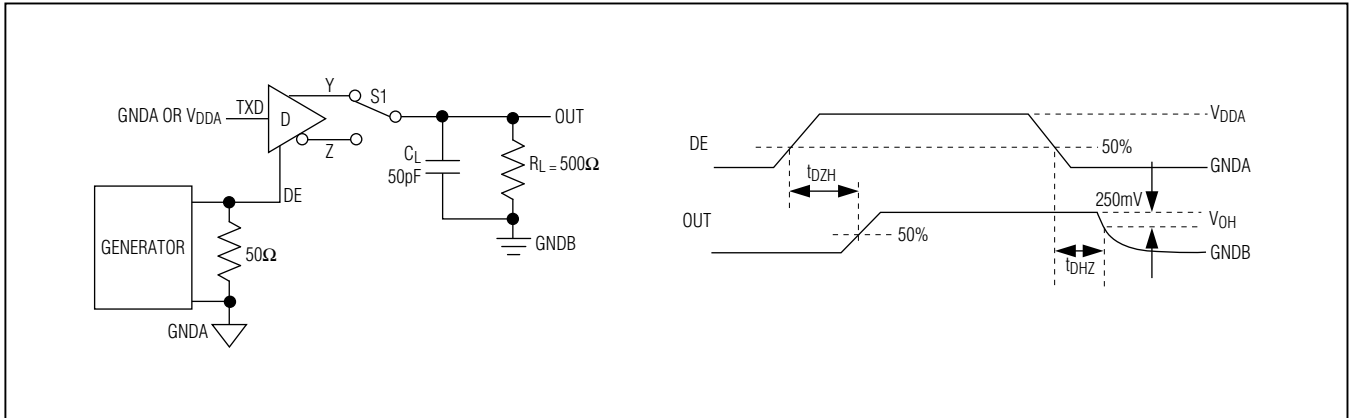

Figure 4. Driver Enable and Disable Times ( $t_{DZH}$ ,  $t_{DZH}$ )

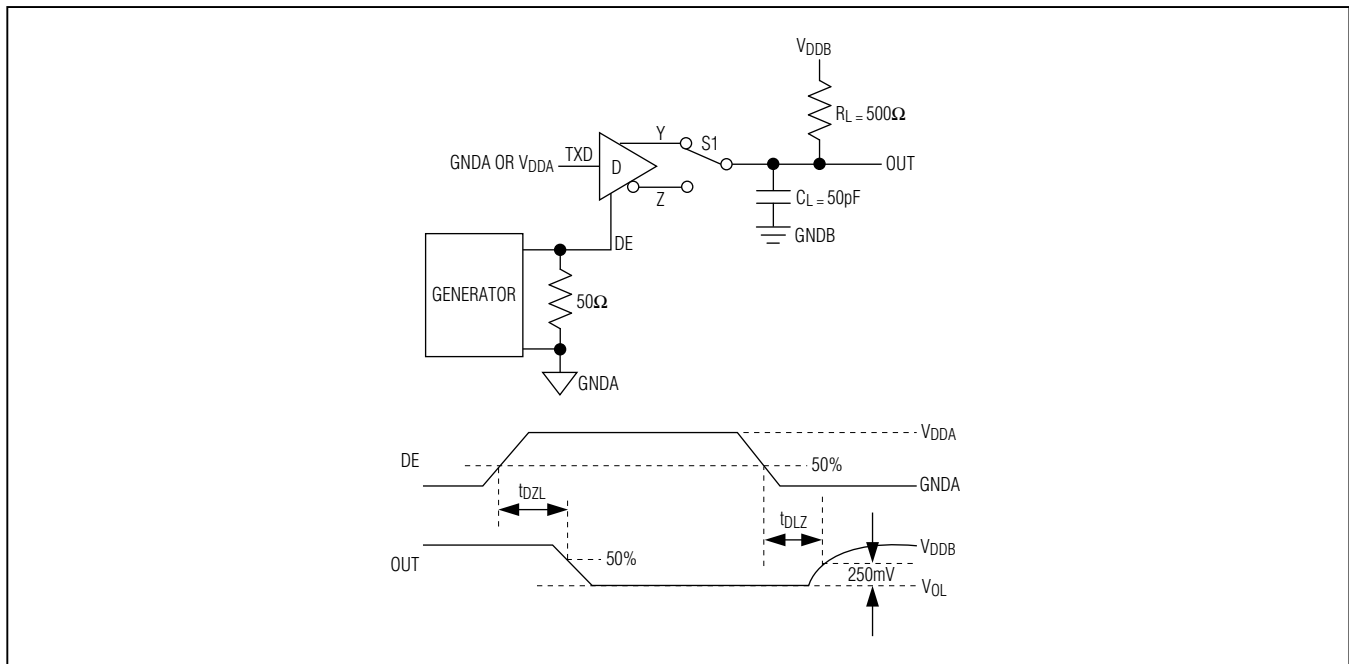

Figure 5. Driver Enable and Disable Times ( $t_{DZL}$ ,  $t_{DLZ}$ )

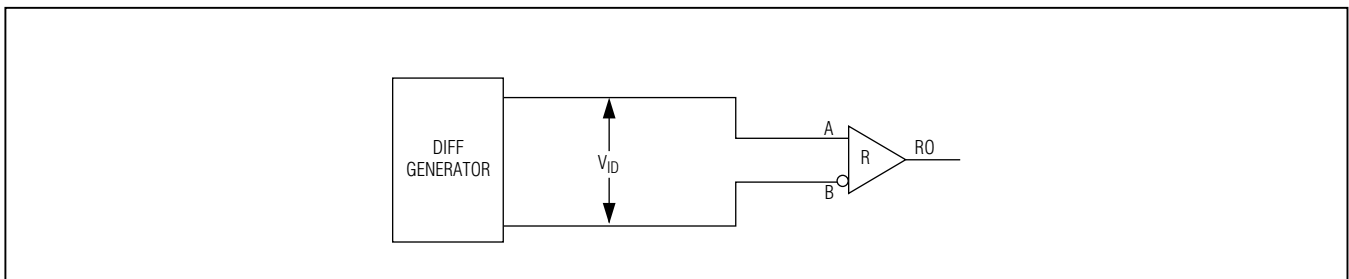

Figure 6. Receiver Propagation Delay Test Circuit

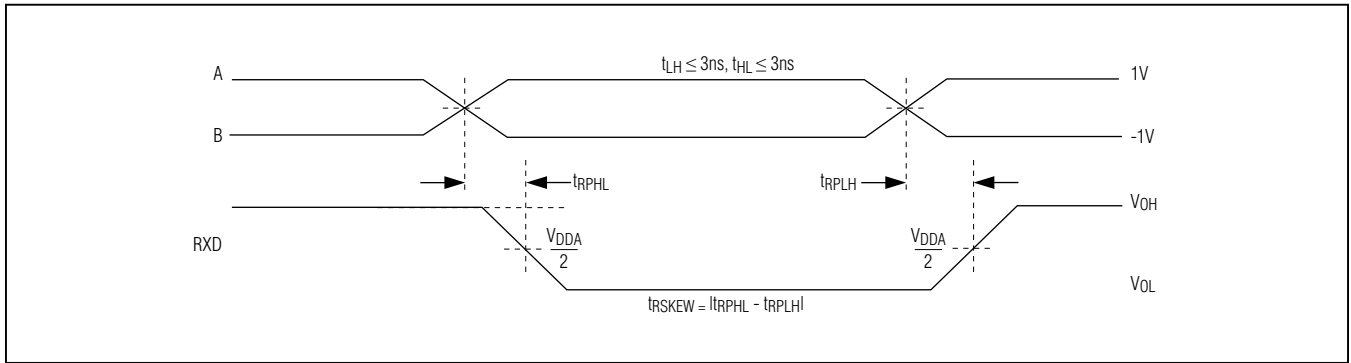

Figure 7. Receiver Propagation Delays

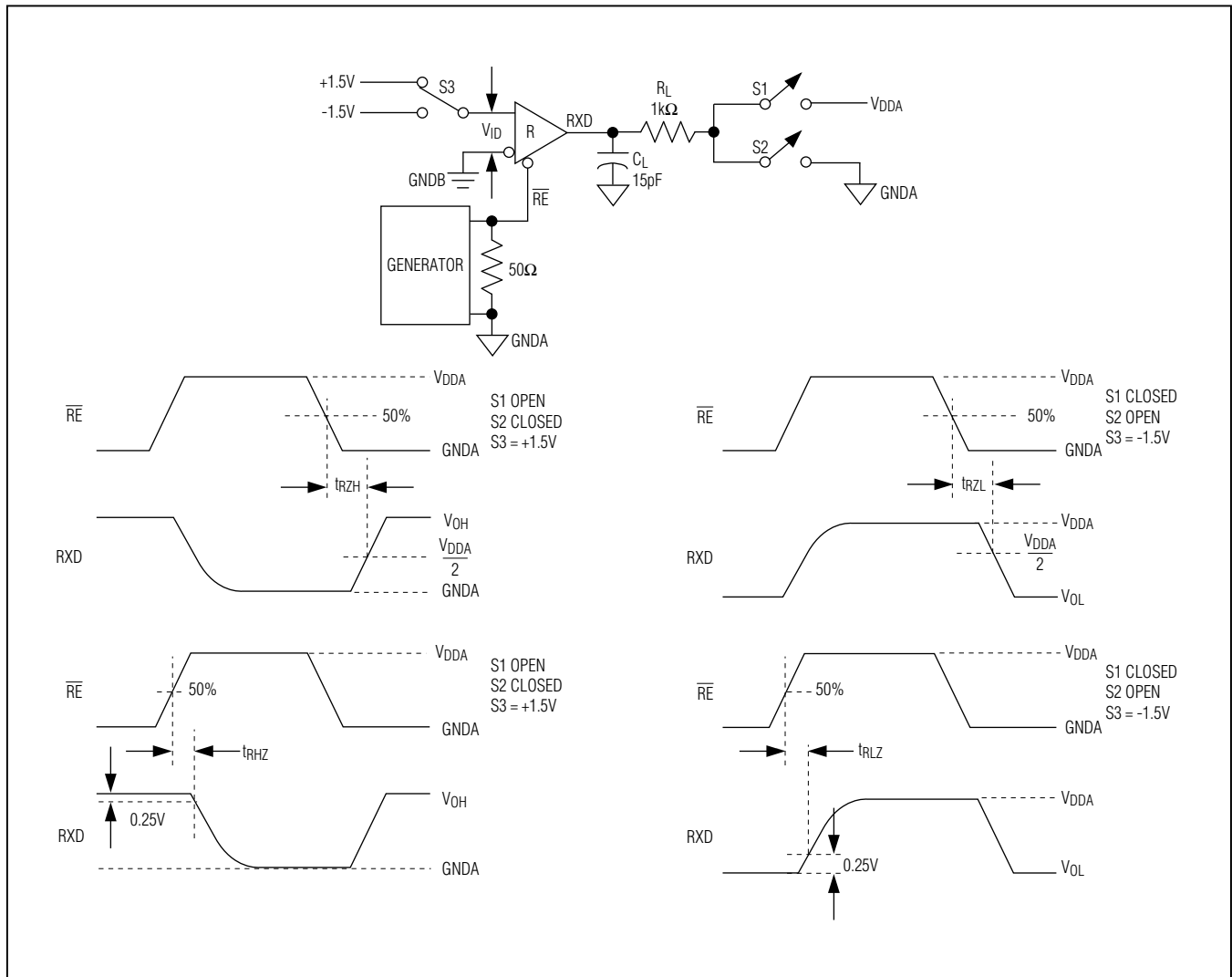
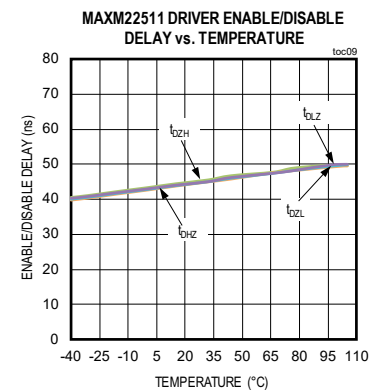
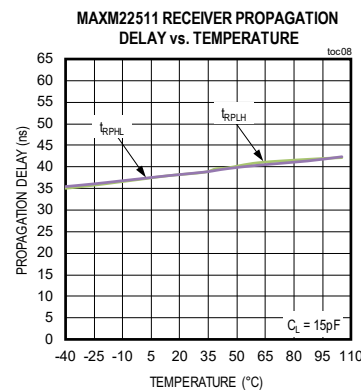
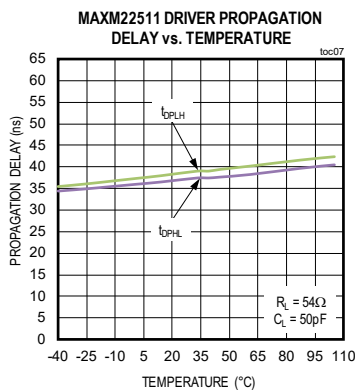
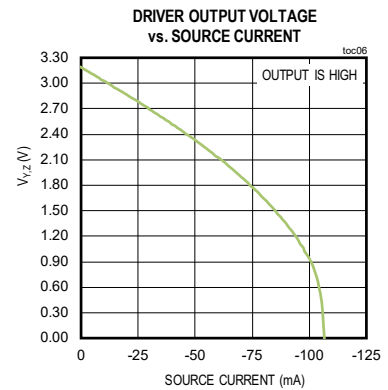
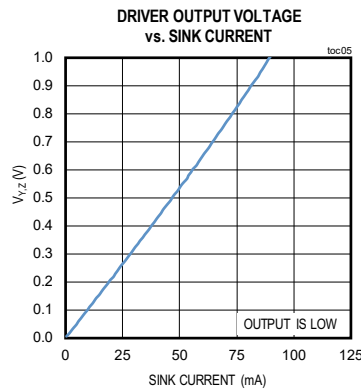
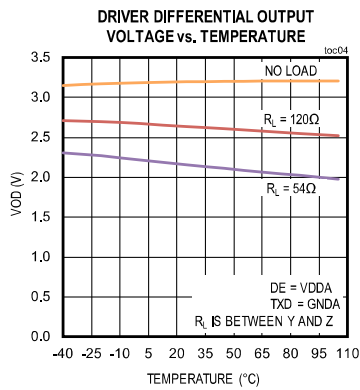
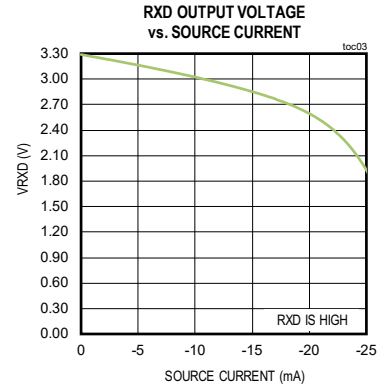
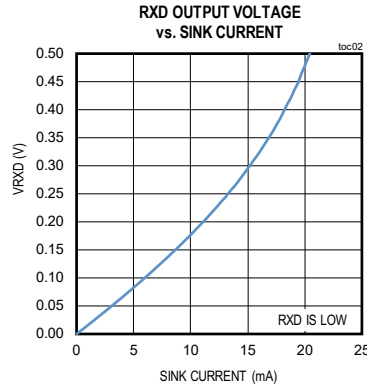
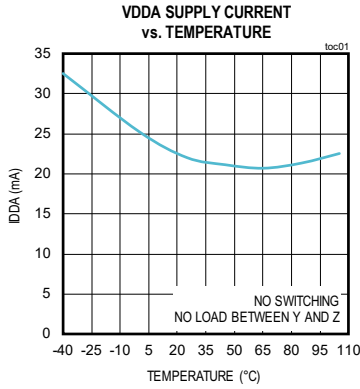

Figure 8. Receiver Enable and Disable Times

Typical Operating Characteristics

( $V_{DDA} - V_{GNDA} = 3.3V$ ,  $V_{GNDA} = V_{GNDB}$ , and  $T_A = +25^\circ C$ , unless otherwise noted.)



Typical Operating Characteristics (continued)

( $V_{DDA} - V_{GNDA} = 3.3V$ ,  $V_{GNDA} = V_{GNDB}$ , and  $T_A = +25^\circ C$ , unless otherwise noted.)

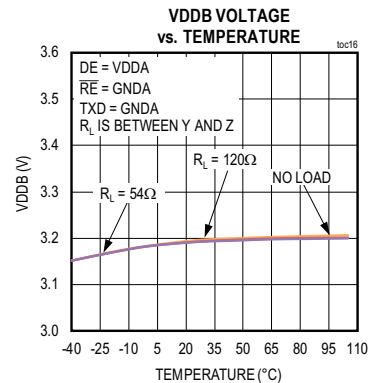
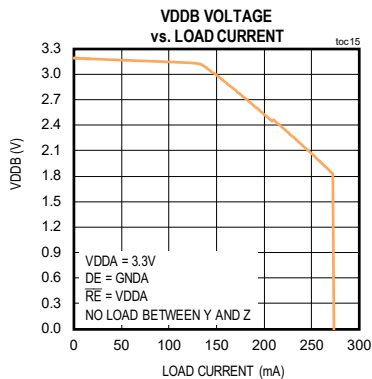
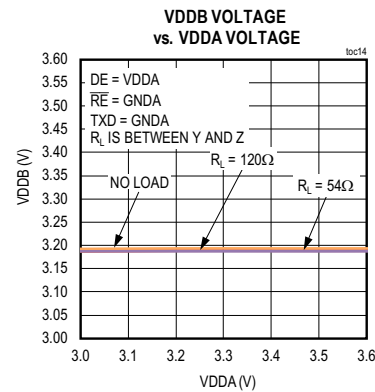
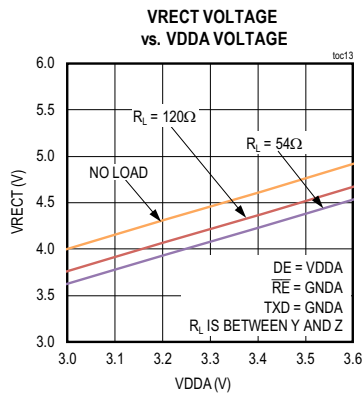
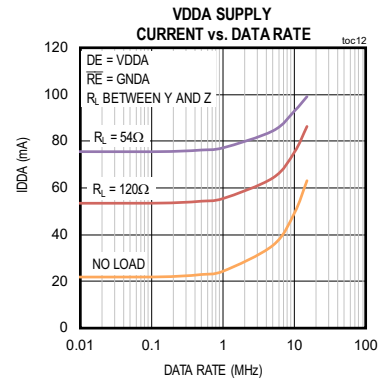
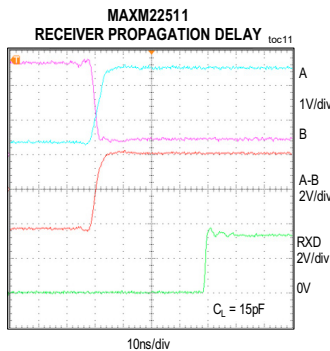
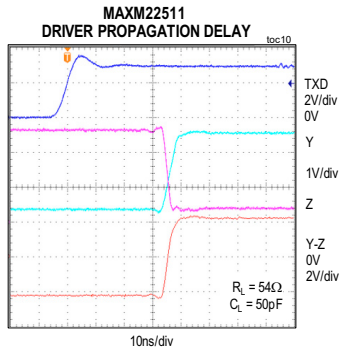

**Typical Operating Characteristics (continued)**

( $V_{DDA} - V_{GNDA} = 3.3V$ ,  $V_{GNDA} = V_{GNDB}$ , and  $T_A = +25^\circ C$ , unless otherwise noted.)

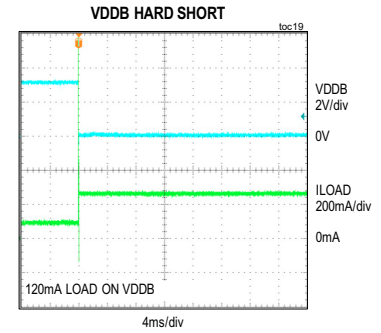
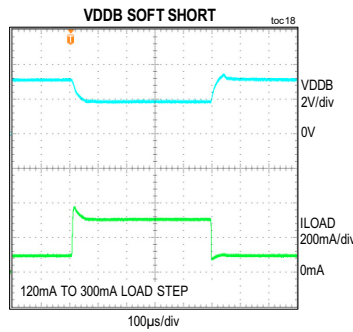
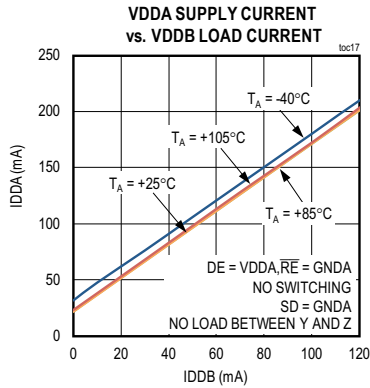

Pin Configuration

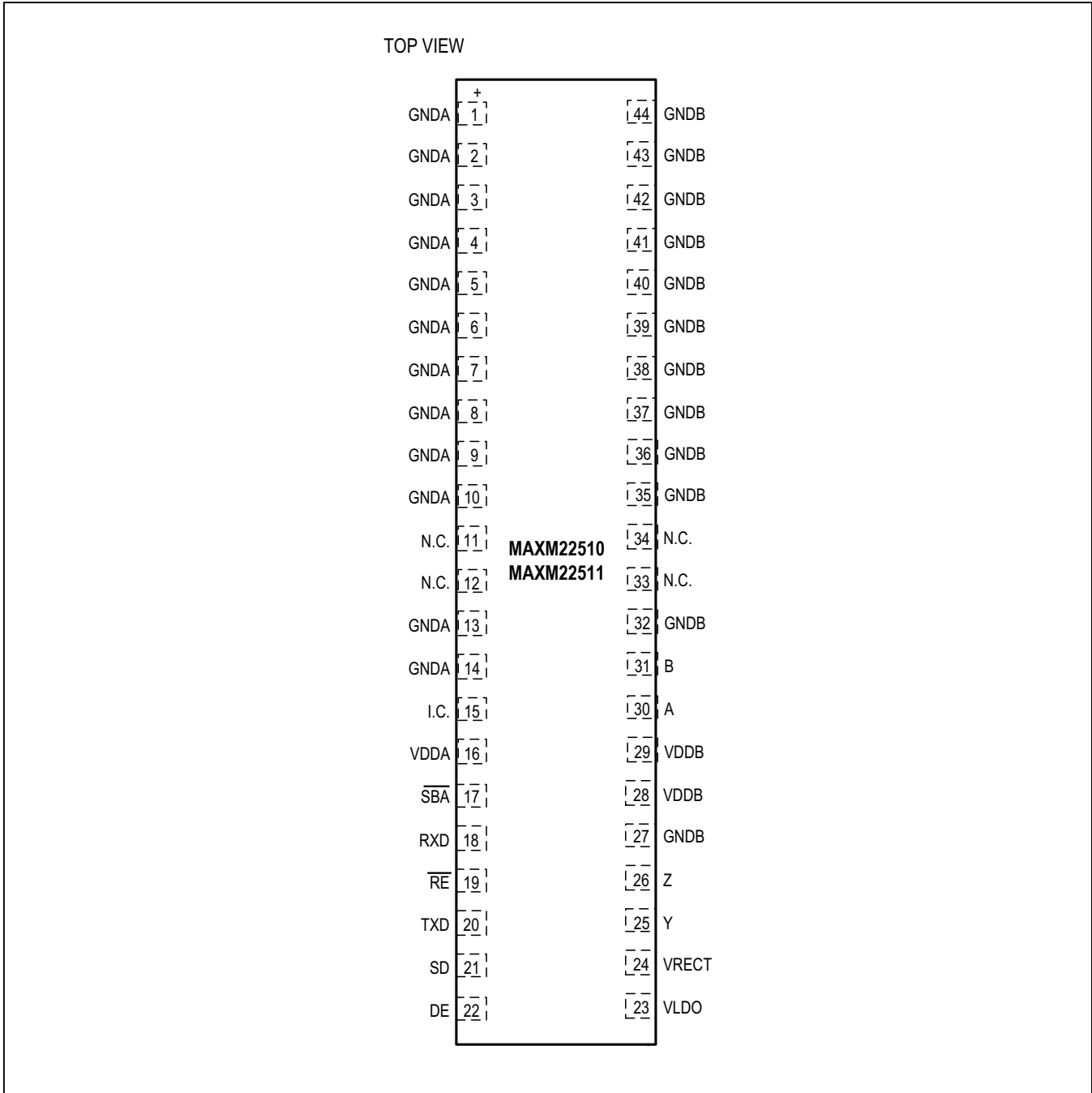

## Pin Description

PIN	NAME	REFERENCE	FUNCTION
1-10, 13, 14	GNDA	—	UART-side/Side A Ground. GNDA is the ground reference for digital signals and the UART-side/side A power supply.
11, 12, 33, 34	N.C.	—	Not Connected. Not internally connected.
15	I.C.	GNDA	Internally Connected. Leave I.C. unconnected.
16	V <sub>DDA</sub>	GNDA	UART-side/Side A Power Input. Apply a 3.3V supply voltage to V <sub>DDA</sub> .
17	$\overline{\text{SBA}}$	GNDA	Cable-side/Side B Active Indicator Open-Drain Output. $\overline{\text{SBA}}$ asserts low when the cable-side/side B is powered and working. $\overline{\text{SBA}}$ has an internal 5k $\Omega$ pullup resistor to V <sub>DDA</sub> . $\overline{\text{SBA}}$ is high impedance when the device is in shutdown (SD is high).
18	RXD	GNDA	Receiver Data Output. Drive $\overline{\text{RE}}$ low to enable RXD. With $\overline{\text{RE}}$ low, RXD is high when $(V_A - V_B) > -10\text{mV}$ and is low when $(V_A - V_B) < -200\text{mV}$ . RXD is high when V <sub>DDB</sub> is less than V <sub>UVLOB</sub> . RXD is high-impedance when $\overline{\text{RE}}$ is high or when SD is high.
19	$\overline{\text{RE}}$	GNDA	Receiver Output Enable. Drive $\overline{\text{RE}}$ low or connect to GNDA to enable RXD. Drive $\overline{\text{RE}}$ high to disable RXD. RXD is high-impedance when $\overline{\text{RE}}$ is high. $\overline{\text{RE}}$ has an internal 4.5 $\mu\text{A}$ pulldown to GNDA.
20	TXD	GNDA	Driver Input. With DE high, a low on TXD forces the noninverting output (Y) low and the inverting output (Z) high. Similarly, a high on TXD forces the noninverting output high and the inverting output low. TXD has an internal 4.5 $\mu\text{A}$ pull-up to V <sub>DDA</sub> .
21	SD	GNDA	Shutdown Input. Drive SD low for normal operation. Drive SD high to force the part into shutdown mode. When SD is high, the logic inputs/outputs are in a reset state and the cable-side/side B of the device is unpowered. Do not leave SD disconnected.
22	DE	GNDA	Driver Output Enable. Drive DE high to enable bus driver outputs Y and Z on the cable-side/side B of the device. Drive DE low to disable Y and Z. Y and Z are high impedance when DE is low. DE has an internal 4.5 $\mu\text{A}$ pull-down to GNDA.
23	V <sub>LDO</sub>	GNDB	Cable-side/Side B LDO Input. Connect V <sub>LDO</sub> to V <sub>RECT</sub> to power the cable-side of the device.
24	V <sub>RECT</sub>	GNDB	Cable-side/Side B DC-DC Unregulated Output. Connect V <sub>RECT</sub> to V <sub>LDO</sub> to power the cable-side of the device.
25	Y	GNDB	Noninverting Driver Output
26	Z	GNDB	Inverting Driver Output
27, 32, 35-44	GNDB	—	Cable-Side/Side B Ground. GNDB is the ground reference for the internal LDO and the RS-485/RS-422 bus signals.
28, 29	V <sub>DDB</sub>	GNDB	Cable-Side/Side B LDO Power Output. V <sub>DDB</sub> is the output of the internal LDO.
30	A	GNDB	Noninverting Receiver Input
31	B	GNDB	Inverting Receiver Input

## Function Tables

TRANSMITTING						
INPUTS				OUTPUTS		
V <sub>DDA</sub>	V <sub>DDB</sub>	SD	DE*	TXD	Y	Z
≥ V <sub>UVLOA</sub>	≥ V <sub>UVLOB</sub>	0	1	1	1	0
				0	0	1
	< V <sub>UVLOB</sub>		X	X	High-Z	High-Z
< V <sub>UVLOA</sub>	X	0	X	X	High-Z	High-Z
X	X	1	X	X	High-Z	High-Z

\*Note: Drive DE low to disable the transmitter outputs. Drive DE high to enable the transmitter outputs. DE has an internal pulldown to G<sub>ND</sub>A.

X = Don't care

RECEIVING (DE = 0)					
INPUTS				OUTPUTS	
V <sub>DDA</sub>	V <sub>DDB</sub>	SD	$\overline{RE}^*$	(V <sub>A</sub> - V <sub>B</sub> )	RXD
≥ V <sub>UVLOA</sub>	≥ V <sub>UVLOB</sub>	0	0	> -10mV	1
				< -200mV	0
			Open/Short	1	
< V <sub>UVLOA</sub>	< V <sub>UVLOB</sub>	0	1	X	High-Z
			0	X	1
< V <sub>UVLOA</sub>	< V <sub>UVLOB</sub>	0	0	X	1**
X	X	1	X	X	High-Z

\*Note: Drive  $\overline{RE}$  high to disable the receiver output. Drive  $\overline{RE}$  low to enable to receiver output.  $\overline{RE}$  has an internal pulldown to G<sub>ND</sub>A.

\*\*Note: RXD goes high impedance when V<sub>DDA</sub> falls below 1.6V (typ).

X = Don't care

$\overline{SBA}$			
V <sub>DDA</sub>	V <sub>DDB</sub>	SD	$\overline{SBA}$
< V <sub>UVLOA</sub>	< V <sub>UVLOB</sub>	0	High
≥ V <sub>UVLOA</sub>	< V <sub>UVLOB</sub>	0	High
	≥ V <sub>UVLOB</sub>	0	Low
X	X	1	High-Z

X = Don't care



## Detailed Description

The MAXM22510/MAXM22511 isolated RS-485/RS-422 full-duplex transceiver modules provide 2500V<sub>RMS</sub> (60s) of galvanic isolation between the RS-485/RS-422 cable-side of the transceiver and the UART-side. These integrated modules require no external components and no external isolated power supply for the cable-side.

These transceivers allow up to 500kbps (MAXM22510) or 25Mbps (MAXM22511) communication across an isolation barrier when a large potential exists between grounds on each side of the barrier.

### Data Isolation

Data isolation is achieved using high-voltage capacitors that allow data transmission between the UART-side and the RS-485/RS-422 cable-side of the transceiver.

### Integrated DC-DC for Isolated Power

Power isolation is achieved with an integrated DC-DC and LDO. A single 3.3V supply on the UART-side of the device is used to generate a regulated 3.3V supply for the cable-side.

The internal transformer used to transfer isolated power in the MAXM22510/MAXM22511 is based on a ferrite core to help reduce unwanted EMI emissions.

No power is transferred from the UART-side to the cable-side when the shutdown pin (SD) is high.

### True Fail-Safe

The devices guarantee a logic-high on the receiver output when the receiver inputs are shorted or open, or when connected to a terminated transmission line with all drivers disabled. The receiver threshold is fixed between -10mV and -200mV. If the differential receiver input voltage ( $V_A - V_B$ ) is greater than or equal to -10mV, RXD is logic-high. In the case of a terminated bus with all transmitters

disabled, the receiver's differential input voltage is pulled to zero by the termination resistors. Due to the receiver threshold of the devices, this results in a logic-high at RXD.

### Driver Output Protection

Two mechanisms prevent excessive output current and power dissipation caused by faults or bus contention. The first, a current limit on the output stage, provides immediate protection against short circuits over the entire common-mode voltage range. The second, a thermal-shutdown circuit, forces the driver outputs into a high-impedance state if the die temperature exceeds +160°C (typ).

### Thermal Shutdown

The devices are protected from overtemperature damage by integrated thermal-shutdown circuitry. When the junction temperature ( $T_J$ ) exceeds +160°C (typ), the driver outputs and RXD are high-impedance, and V<sub>DDB</sub> falls to 0V. The device resumes normal operation when  $T_J$  falls below +145°C (typ).

## Applications Information

### 128 Transceivers on the Bus

The standard RS-485 receiver input impedance is one unit load. A standard driver can drive up to 32 unit-loads. The MAXM22510/MAXM22511 transceivers have a 1/4-unit load receiver, which allows up to 128 transceivers, connected in parallel, on one communication line. Connect any combination of these devices, and/or other RS-485 devices, for a maximum of 32 unit-loads to the line.

### Typical Application

The MAXM22510/MAXM22511 full-duplex transceivers are designed for bidirectional data communications on multi-point bus transmission lines. [Figure 9](#) and [Figure 10](#) show

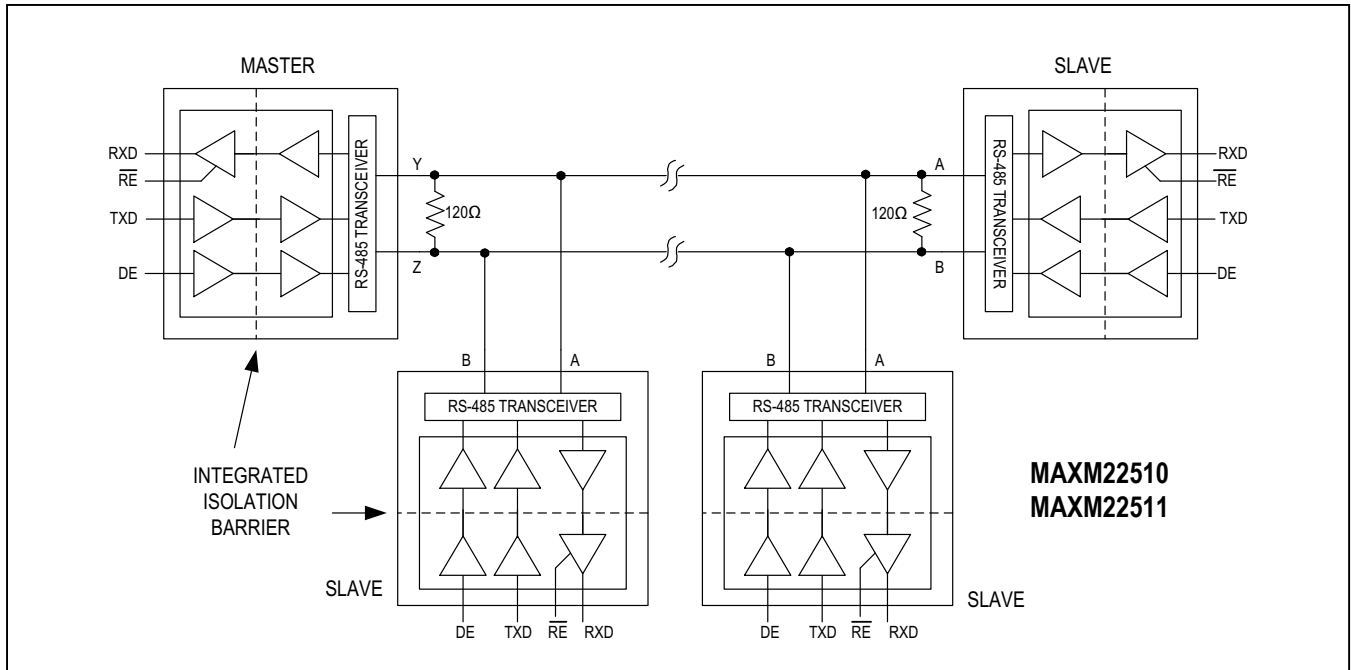

Figure 9. Typical Isolated Full-Duplex RS-485/RS-422 Application

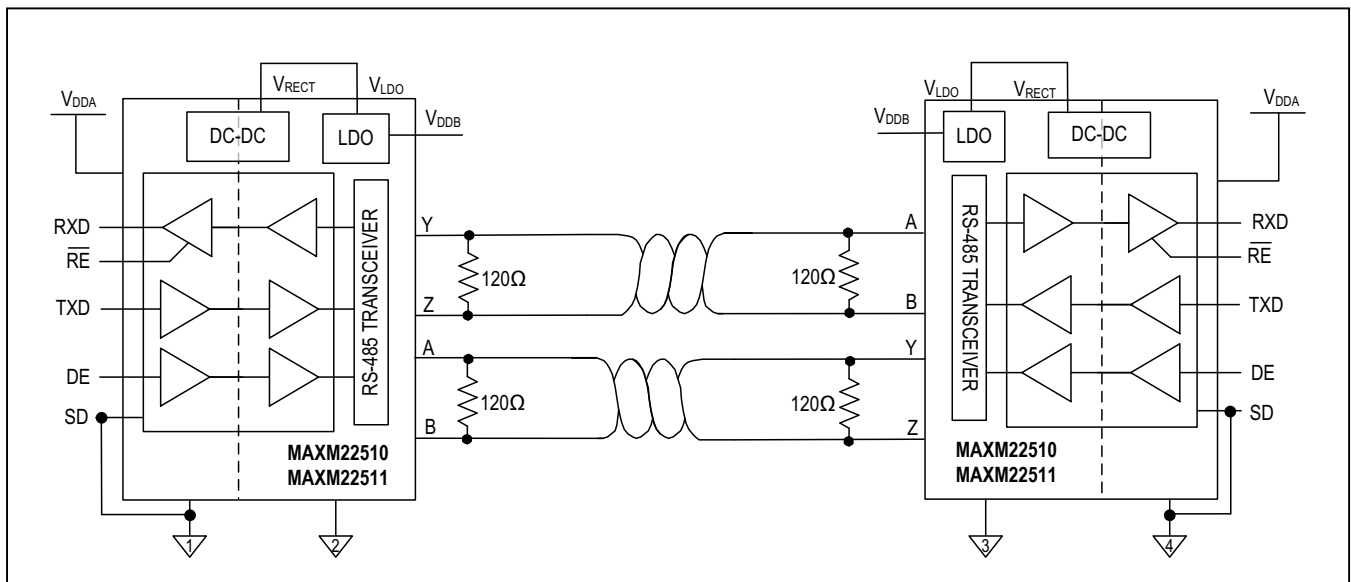

Figure 10. Typical Isolated Point-to-Point Application

typical network application circuits. To minimize reflections, the bus should be terminated at both ends in its characteristics impedance, and stub lengths off the main line should be kept as short as possible.

### Layout Considerations

It is recommended to design an isolation, or “keep-out,” channel underneath the isolator that is free from ground and signal planes. Any galvanic or metallic connection between the cable-side and UART-side will defeat the isolation.

Route important signal lines close to the ground plane to minimize possible external influences. On the cable-side of the devices, it is good practice to have the bus connectors and termination resistor as close as possible to the I/O pins.

### Extended ESD Protection

ESD protection structures are incorporated on all pins to protect against electrostatic discharge encountered during handling and assembly. The driver outputs and receiver inputs of the devices have extra protection against static electricity to the cable-side ground reference. The ESD structures withstand high-ESD events during normal operation and when powered down. After an ESD event, the devices keep working without latch-up or damage.

Optionally, place a 330pF Y capacitor between GNDA and GNDB for improved cable-side to UART-side ESD protection.

ESD protection can be tested in various ways. The transmitter outputs and receiver inputs of the MAXM22510/MAXM22511 are characterized for protection to the cable-side ground (GNDB) to the following limits:

- ±35kV HBM
- ±18kV using the Air-Gap Discharge method specified in IEC 61000-4-2
- ±8kV using the Contact Discharge method specified in IEC 61000-4-2

### ESD Test Conditions

ESD performance depends on a variety of conditions. Contact Maxim for a reliability report that documents test setup, test methodology, and test results.

### Human Body Model (HBM)

[Figure 11](#) shows the HBM test model, while [Figure 12](#) shows the current waveform it generates when discharged in a low-impedance state. This model consists of a 100pF capacitor charged to the ESD voltage of interest, which is then discharged into the test device through a 1.5kΩ resistor.

### IEC 61000-4-2

The IEC 61000-4-2 standard covers ESD testing and performance of finished equipment. However, it does not specifically refer to integrated circuits. The devices help in designing equipment to meet IEC 61000-4-2 without the need for additional ESD protection components.

The major difference between tests done using the HBM and IEC 61000-4-2 is higher peak current in IEC 61000-4-2 because series resistance is lower in the IEC 61000-4-2 model. Hence, the ESD withstand voltage measured to IEC 61000-4-2 is generally lower than that measured using the HBM.

[Figure 13](#) shows the IEC 61000-4-2 model and [Figure 14](#) shows the current waveform for IEC 61000-4-2 ESD Contact Discharge Test.

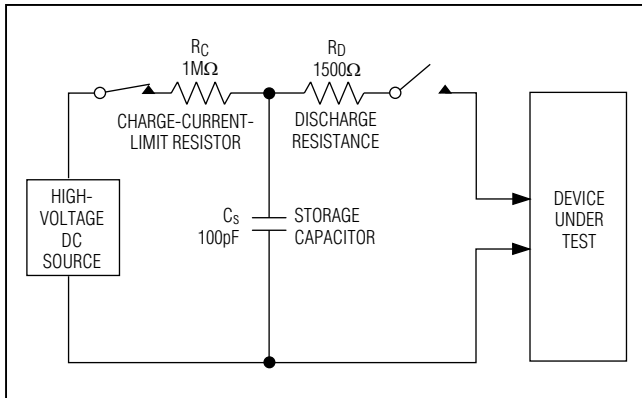

Figure 11. Human Body ESD Test Model

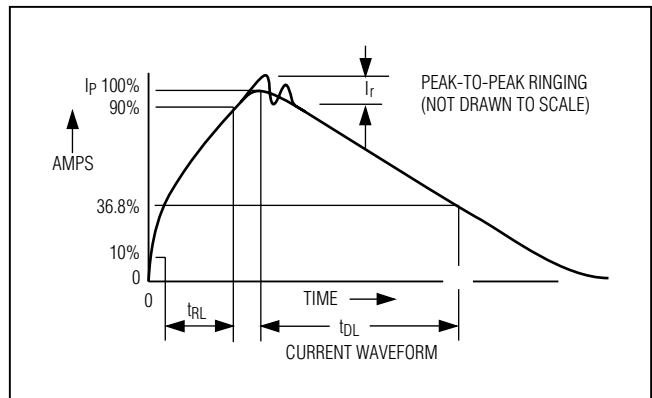

Figure 12. Human Body Current Waveform

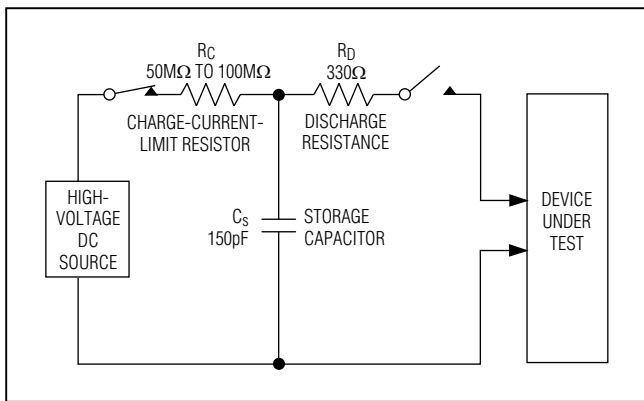

Figure 13. IEC 61000-4-2 ESD Test Model

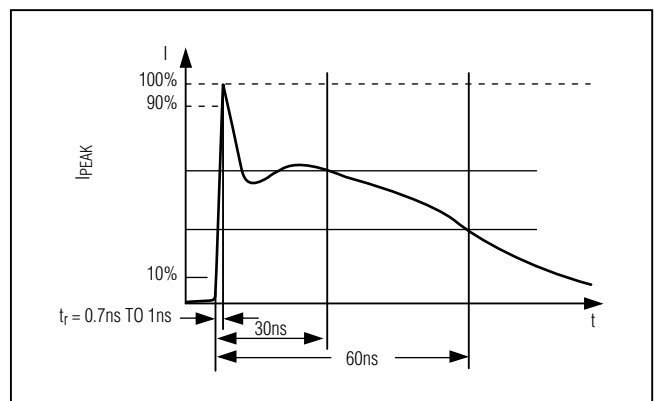
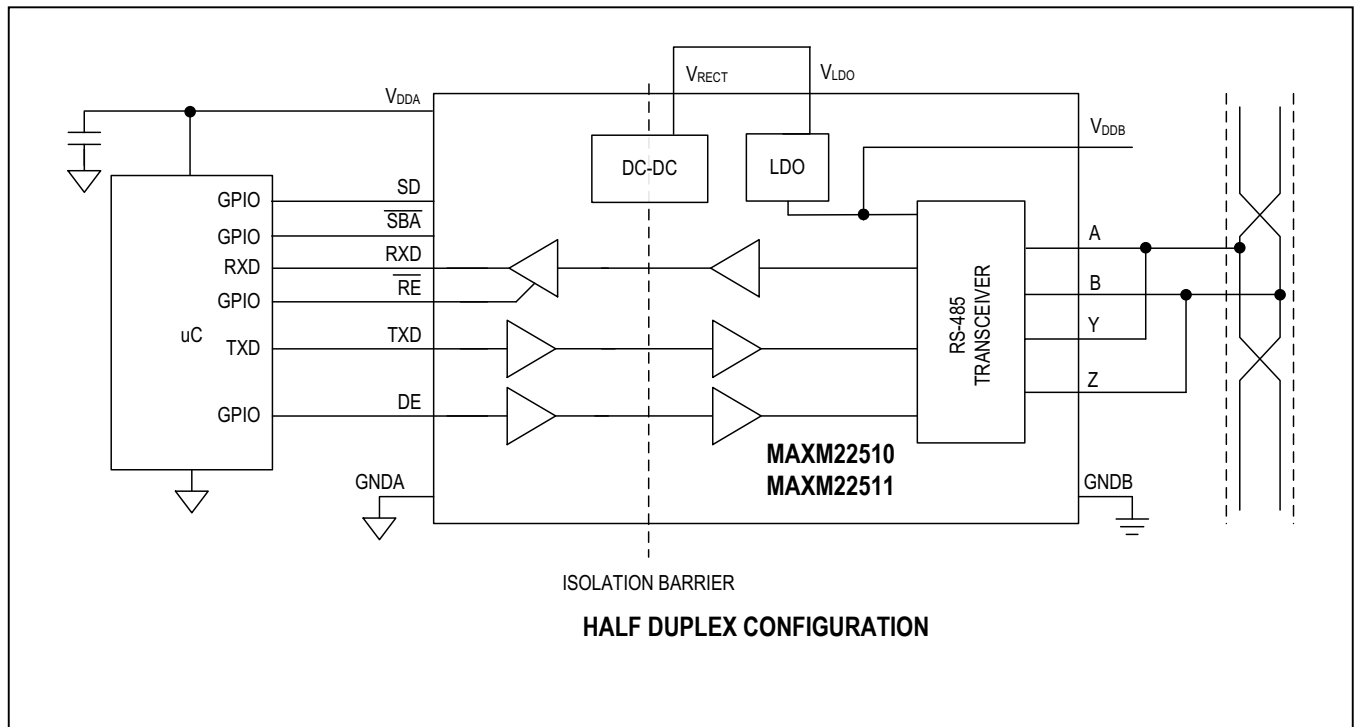
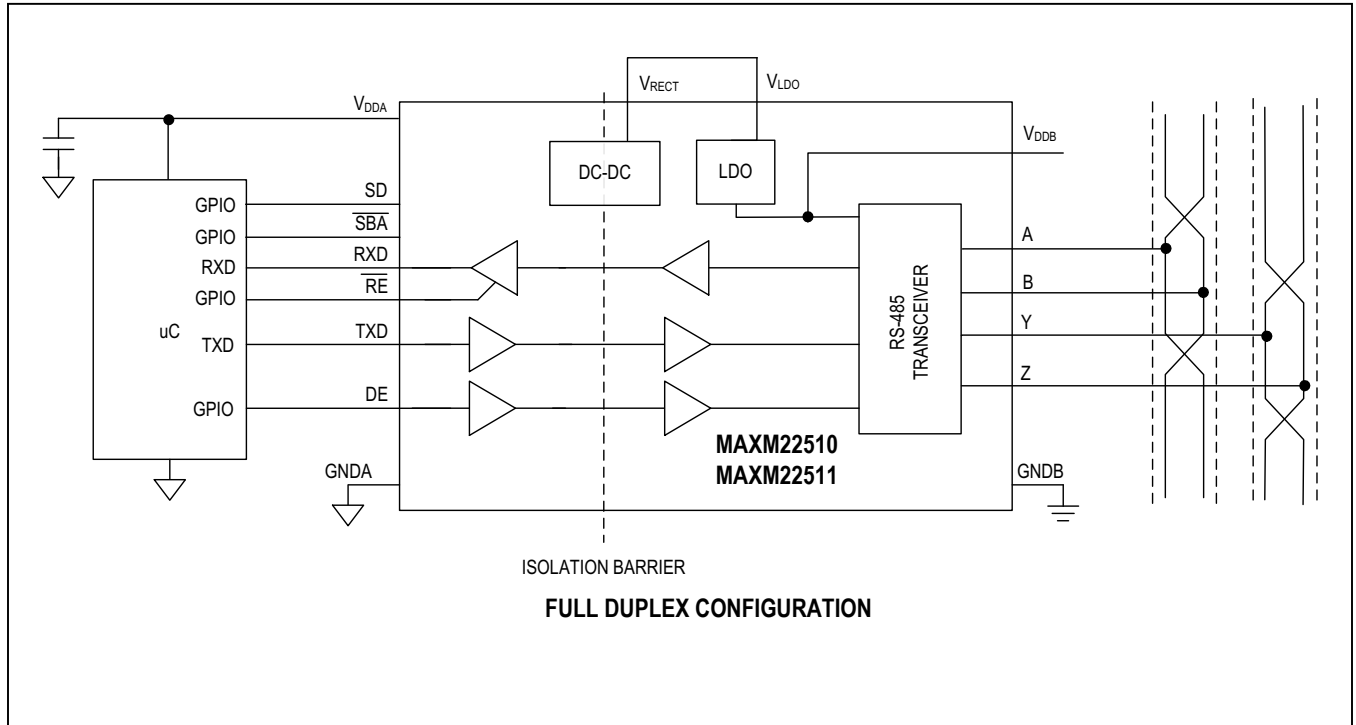

Figure 14. IEC 61000-4-2 ESD Generator Current Waveform

Typical Application Circuits



## Ordering Information

PART	TEMP RANGE	PIN-PACKAGE
<b>MAXM22510GLH+*</b>	-40°C to +105°C	44 LGA
MAXM22510GLH+T*	-40°C to +105°C	44 LGA
<b>MAXM22511GLH+</b>	-40°C to +105°C	44 LGA
MAXM22511GLH+T	-40°C to +105°C	44 LGA

+Denotes a lead(Pb)-free/RoHS-compliant package.

\*Future Product—Contact factory for availability.

T = Tape and reel.

## Chip Information

PROCESS: BiCMOS

## Package Information

For the latest package outline information and land patterns (footprints), go to [www.maximintegrated.com/packages](http://www.maximintegrated.com/packages). Note that a "+", "#", or "-" in the package code indicates RoHS status only. Package drawings may show a different suffix character, but the drawing pertains to the package regardless of RoHS status.

PACKAGE TYPE	PACKAGE CODE	OUTLINE NO.	LAND PATTERN NO.
44 LGA	L44119M+1	<a href="#">21-100226</a>	<a href="#">90-100107</a>

## Revision History

REVISION NUMBER	REVISION DATE	DESCRIPTION	PAGES CHANGED
0	6/18	Initial release	—
16, 1	7/18	Updated <i>General Description, Benefits and Features, Package Thermal Characteristics, Electrical Characteristics table, Typical Operating Characteristics, Pin Description, Function Tables, and Detailed Description</i>	1, 2, 4–6, 11–13, 15, 16, 17, 19

For pricing, delivery, and ordering information, please visit Maxim Integrated's online storefront at <https://www.maximintegrated.com/en/storefront/storefront.html>.

Maxim Integrated cannot assume responsibility for use of any circuitry other than circuitry entirely embodied in a Maxim Integrated product. No circuit patent licenses are implied. Maxim Integrated reserves the right to change the circuitry and specifications without notice at any time. The parametric values (min and max limits) shown in the Electrical Characteristics table are guaranteed. Other parametric values quoted in this data sheet are provided for guidance.