

Tronics Product Brief 2019

High Performance MEMS Inertial Sensors

Sensors for Precision Navigation, Stabilization and Motion Control

Features

- 24-bit SPI digital output
- Hermetic ceramic package
- Closed-loop operation
- Embedded temperature sensor
- Built-in self test
- REACH and RoHS-compatible
- Industrial temperature range from $-40\text{ }^{\circ}\text{C}$ up to $+85\text{ }^{\circ}\text{C}$
- Evaluation kit compatible with Arduino platform

Applications

- Motion tracking
- Platform stabilization
- GNSS assistance
- AHRS & IMU
- Flight control
- Guidance
- Precision instrumentation



High Performance Sensors for Precision Navigation and Stabilization

Introduction

Tronics Microsystems, a TDK Group Company, is a division of TDK's Temperature & Pressure Sensors Business Group and a recognized technological leader in the sector of nano- and microsystems. Addressing high-growth markets relying on increasing miniaturization of electronic devices, the company provides custom and standard products especially to the industrial, aeronautics, security, and medical markets.

Tronics is the only provider of both closed-loop MEMS accelerometers (measuring linear acceleration) and MEMS gyros (measuring angular rates), taking MEMS inertial sensors to an unrivalled level of performance. Closed-loop electronics, also called force-feedback, brings several key advantages to inertial sensors, including superior linearity, increased signal to noise ratio and improved behavior under vibrations, shocks and temperature environments.



Inertial sensing is among the most important and well-established function for high precision navigation and guidance, as well as stabilization.

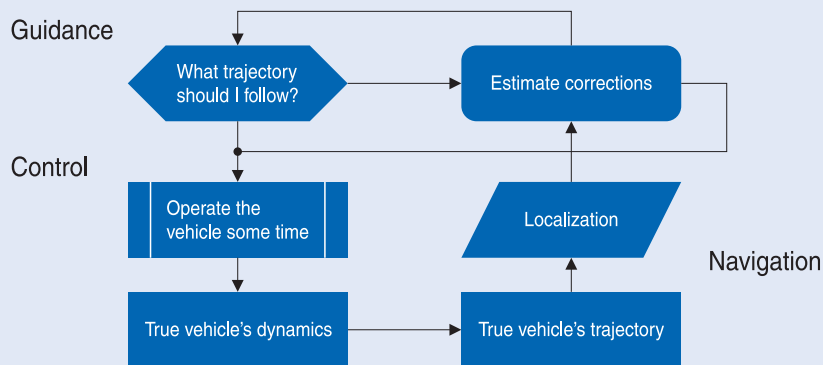

TNT0701-M

At the request of systems manufacturers currently transitioning from old inertial technologies to silicon MEMS, Tronics has introduced in recent years several new MEMS gyros (measuring angular rates) and MEMS accelerometers (measuring linear accelerations). These products have already been successfully deployed on a large range of precision navigation and stabilization applications, and we still develop additional innovative products to meet new customers' requirements.

Tronics MEMS sensors stand for excellent measuring accuracy and long-term stability. Our sensors are available in a hermetically sealed ceramic package for extended lifetime in adverse environments. After calibration and verification, each sensor is delivered with a certificate of compliance giving test measurements over the whole temperature range. If standard types do not match the purpose, application-specific sensors with customized configuration and test coverage can also be supplied.

Our design center and plant for inertial sensors is located in France and is ISO 9001:2015 certified. Our sensors do not embed any firmware nor software, thereby easing systems certification.

With our comprehensive sensor portfolio we help system manufacturer's transition to MEMS products with huge benefits in terms of size, weight, power and price and without compromising on performance and reliability.

This product brief presents a selection of our continuously growing portfolio of high performance inertial sensors.

Inertial Sensors for Optical Systems



Motion tracking and stabilization



Vibrations and shocks cause blurring on optical systems such as cameras. This blurring effect can be reduced by mechanical stabilization: A gyro is used to measure the movement and a microcontroller directs that signal to small linear motors compensating for the motion. The control loop should run sufficiently fast in order to resolve the vibrations and provide enhanced image capabilities. Tronics sensors provide an adequate data rate and reduced latency down to 1 ms.

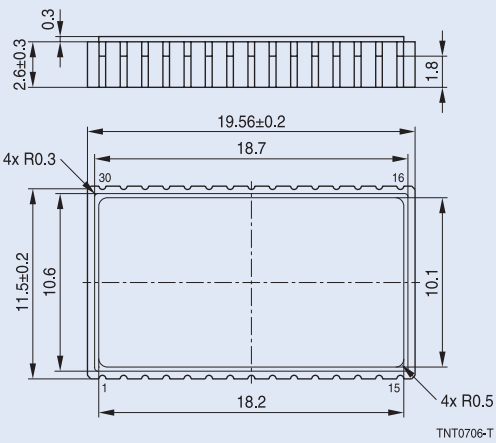

Technical specifications

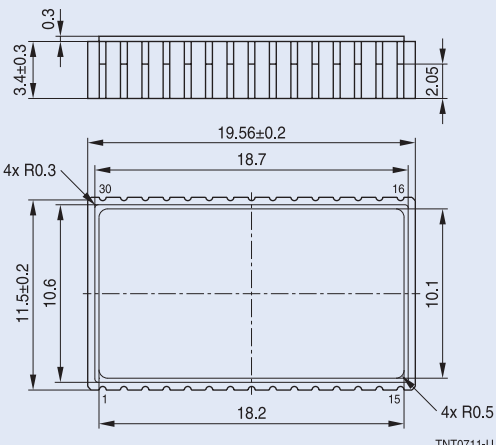
Type	Features	Dimensional drawing
<p>GYPRO2300LD – Gyro</p> 	<ul style="list-style-type: none"> • Z-axis angular rate sensor • Range: ± 300 °/s • Data rate: 1700 Hz • Latency: 2 ms • Noise density: 0.02 °/s/$\sqrt{\text{Hz}}$ • Well-suited for applications with limited vibration environments such as handheld systems 	 <p>TNT0706-T</p>
<p>GYPRO3300 – Gyro</p> 	<ul style="list-style-type: none"> • Z-axis angular rate sensor • Range: up to ± 800 °/s • Data rate: 1800 Hz • Latency: 1 ms • Noise density: 0.04 °/s/$\sqrt{\text{Hz}}$ • Well-suited for harsh environment applications 	 <p>TNT0711-U</p>

Inertial Sensors for Land Vehicles

Precise GNSS-denied navigation



In today's land vehicles, the GNSS (Global Navigation Satellite System) is used as the main navigation system, while MEMS inertial sensing is usually limited to dead-reckoning for emergency stopping during short gaps in GNSS coverage. Thanks to its excellent performance, Tronics high performance MEMS gyro coupled to an odometer now enables reliable, long-term navigation without any external source such as GNSS.

tronics 

Technical specifications

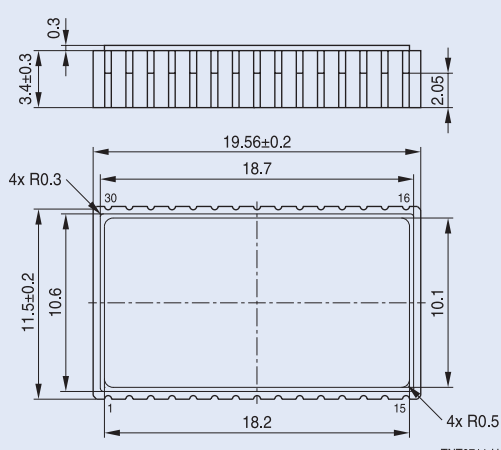
Type	Features	Dimensional drawing
GYPRO3300 – Gyro 	<ul style="list-style-type: none"> • Z-axis angular rate sensor • Range: up to ± 800 °/s • In-run bias stability: 0.8 °/hour • ARW: 0.15 °/$\sqrt{\text{hour}}$ • Well-suited for harsh environments 	 <p>TNT0711-U</p>

Important information: Some parts of this publication contain statements about the suitability of our products for certain areas of application. These statements are based on our knowledge of typical requirements that are often placed on our products. We expressly point out that these statements cannot be regarded as binding statements about the suitability of our products for a particular customer application. It is incumbent on the customer to check and decide whether a product is suitable for use in a particular application. This publication is only a brief product survey which may be changed from time to time. Our products are described in detail in our data sheets. All relevant information is available through our sales offices.