

0.5mm Pitch, Board to Board Connector with Floating Structure

FX20 Series

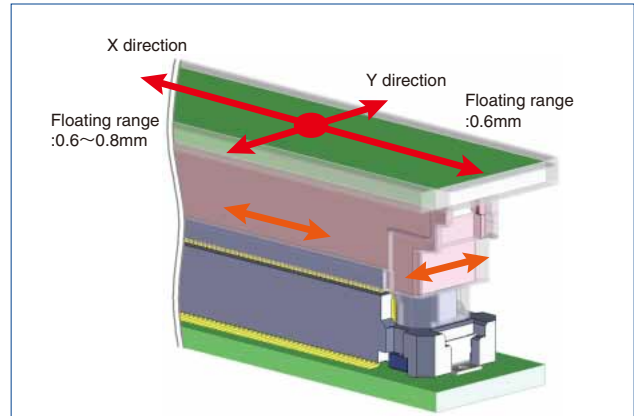
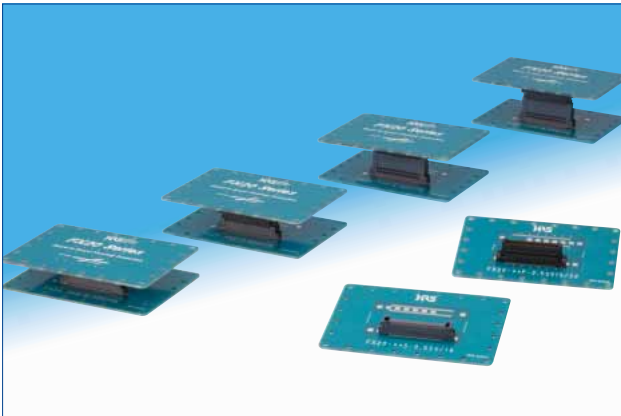

■ Features

1. 0.5mm pitch
2. Connection type: Right angle / Vertical
3. Pin counts : 20, 40, 60, 80, 100, 120 and 140
4. Floating range : ± 0.6 to 0.8mm in the X direction and ± 0.6mm in the Y direction
5. A double beam contact structure produces a highly reliable contact (Refer to the figure on the right)
6. Current capacity : 0.5A per pin
7. Effective mating length of 1.5mm
This connector utilizes a 1.5mm effective mating length for signal contacts and provides a sufficient margin for its mating stroke.
8. No conductive trace surface is not specified
9. Contains the vacuum pick up area needed to allow automatic mounting
10. Self-aligning and self-guiding structure
Built-in guide posts enable self-alignment and ensure a secure connection

Enlarged view of the contact area

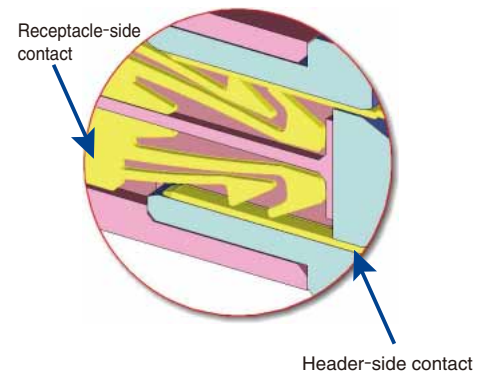

■ Stacking height chart

Receptacle	Header	FX20-***P-0.5SV15	FX20-***P-0.5SV20
FX20-***S-0.5SV		h=15mm	h=20mm
FX20-***S-0.5SV10		h=25mm	h=30mm
FX20-***S-0.5SH		Right angle connection	Right angle connection
Floating range	X direction	±0.6mm	±0.8mm
	Y direction	±0.6mm	±0.6mm

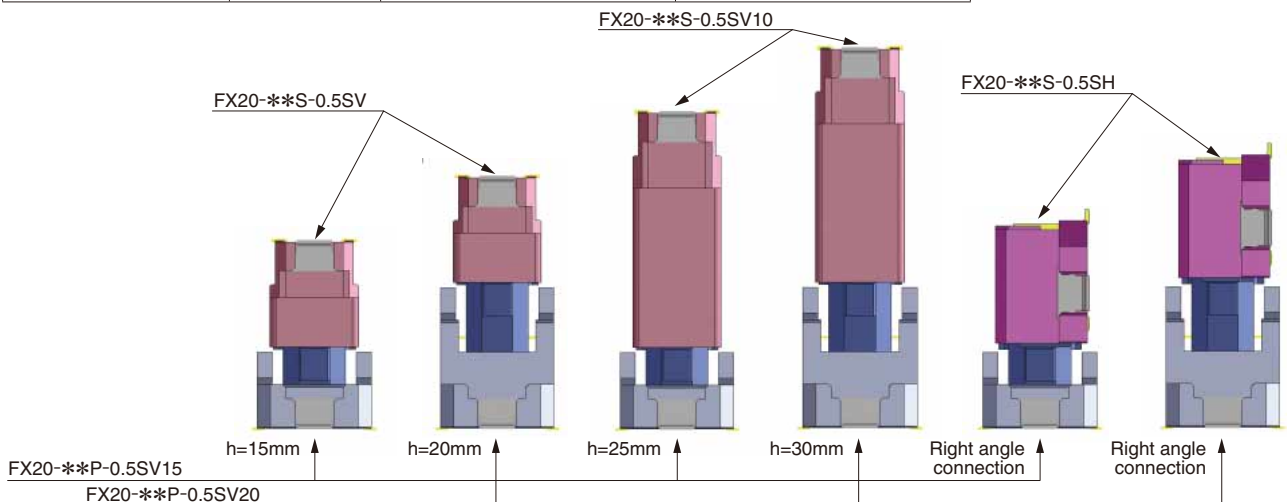

Product Specifications

Ratings	Rated current 0.5A Rated voltage AC 50V	Operating temperature range : -55 to 85°C (Note 1) Storage temperature range : -10 to 60°C (Note 2)
---------	--	--

Item	Standards	Condition
1. Contact resistance	70mΩ max.	100mA(DC or 1000Hz)
2. Insulation resistance	100MΩ min.	100V DC.
3. Voltage proof	No flashover or breakdown.	150V AC for 1 min.
4. Mechanical operation	Contact resistance : Variation from initial value 20mΩ or less. No damage, crack and looseness of parts.	50 times insertions and extractions.
5. Vibration	No electrical discontinuity of 1μs.	Frequency : 10 to 55 to 10Hz, approx 5 min Single amplitude : 0.75mm, 10 cycles for 3 axial directions.
6. Shock	No damage, crack and looseness of parts.	490m/s ² , duration of pulse 11ms at 3 times for 3 both axial directions.
7. Damp heat (Steady state)	Contact resistance : Variation from initial value 20mΩ or less.	Exposed at 40±2°C, 90~95%, 96h.
8. Rapid change of temperature	Insulation resistance : 100MΩ min. No damage, crack and looseness of parts.	Temperature : -55 → +85°C Time : 30 → 30 min. Under 5 cycles(relocation time to chamber : within 2~3min)

Note 1 : Includes temperature rise caused by current flow.

Note 2 : The term "storage" here refers to products stored for a long period prior to board mounting and use.

Materials / Finish

Part	Material		Finish	UL standard
Insulator	Header	PA	Black	UL94V-0
	Receptacle	LCP	Black	UL94V-0
Contacts	Header	Copper alloy	Contact area: Gold plated	_____
	Receptacle	Phosphor bronze	Mounting area: Gold plated	_____
Metal Fitting	Brass		Tin plated	_____

Product Number Structure

Refer to the chart below when determining the product specifications from the product number.

Please select from the product numbers listed in this catalog when placing orders.

●Straight receptacle

FX20 - **60** **S** - **0.5** **SV** **10**
 ① ② ③ ④ ⑤ ⑥

●Straight header

FX20 - **60** **P** - **0.5** **SV** **15**
 ① ② ③ ④ ⑤ ⑥

●Right angle receptacle

FX20 - **60** **S** - **0.5** **SH**
 ① ② ③ ④ ⑤

① Series name	: FX20
② Number (contacts) :	
③ Connector type	S : Receptacle type P : Header type
④ Contact pitch	: 0.5mm
⑤ Housing configuration	: SV : Straight type SH : Right angle type
⑥ Stacking height type	Mating height [mm] = Height of the receptacle-side + Height of the header-side

●Straight receptacle

[FX20-**-S-0.5SV]

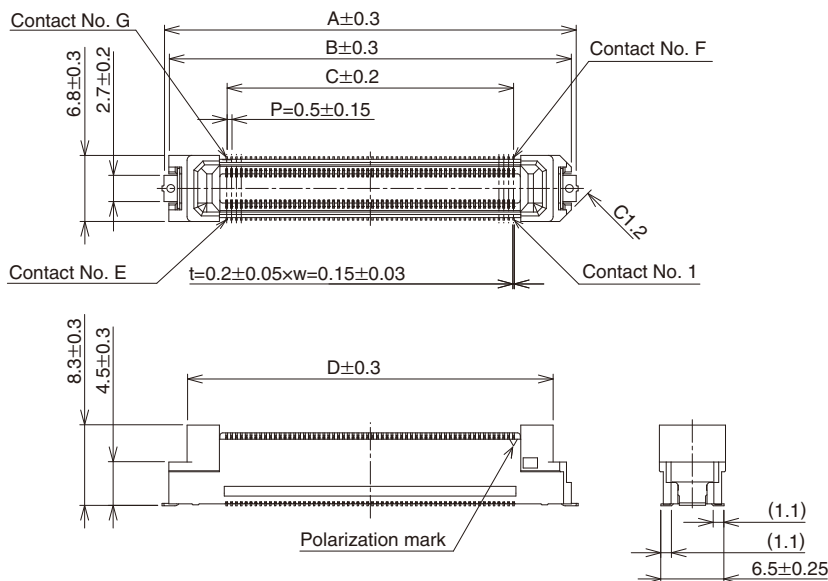

Unit : mm

Part No.	HRS No.	No. of contacts	A	B	C	D	E	F	G
FX20-20S-0.5SV	570-1114-7	20	17.4	16.4	4.5	12.65	10	11	20
FX20-40S-0.5SV	570-1101-5	40	22.4	21.4	9.5	17.65	20	21	40
FX20-60S-0.5SV	570-1102-8	60	27.4	26.4	14.5	22.65	30	31	60
FX20-80S-0.5SV	570-1103-0	80	32.4	31.4	19.5	27.65	40	41	80
FX20-100S-0.5SV	570-1104-3	100	37.4	36.4	24.5	32.65	50	51	100
FX20-120S-0.5SV	570-1105-6	120	42.4	41.4	29.5	37.65	60	61	120
FX20-140S-0.5SV	570-1106-9	140	47.4	46.4	34.5	42.65	70	71	140

[FX20-**-S-0.5SV10]

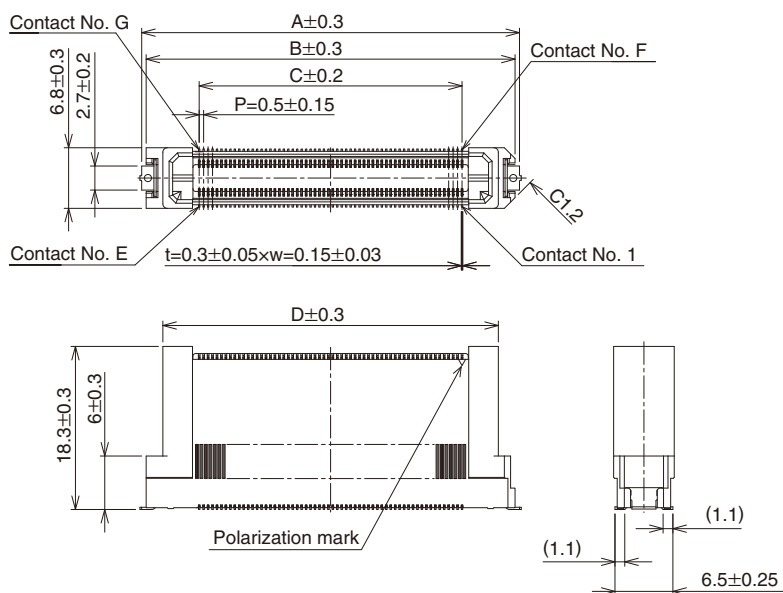

Unit : mm

Part No.	HRS No.	No. of contacts	A	B	C	D	E	F	G
FX20-20S-0.5SV10	570-1115-0	20	17.4	16.4	4.5	12.65	10	11	20
FX20-40S-0.5SV10	570-1107-1	40	22.4	21.4	9.5	17.65	20	21	40
FX20-60S-0.5SV10	570-1108-4	60	27.4	26.4	14.5	22.65	30	31	60
FX20-80S-0.5SV10	570-1109-7	80	32.4	31.4	19.5	27.65	40	41	80
FX20-100S-0.5SV10	570-1110-6	100	37.4	36.4	24.5	32.65	50	51	100
FX20-120S-0.5SV10	570-1111-9	120	42.4	41.4	29.5	37.65	60	61	120
FX20-140S-0.5SV10	570-1112-1	140	47.4	46.4	34.5	42.65	70	71	140

●Straight header

[FX20-**P-0.5SV15]

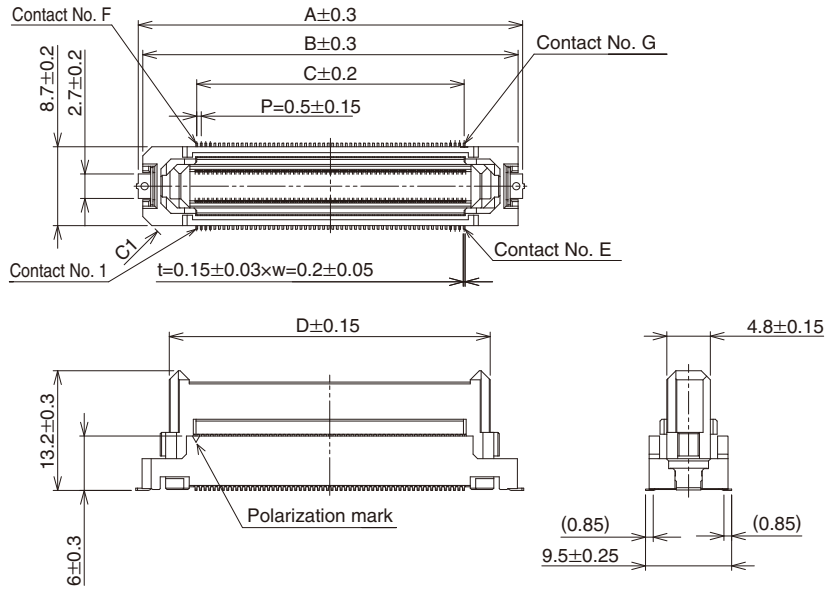

Unit : mm

Part No.	HRS No.	No. of contacts	A	B	C	D	E	F	G
FX20-20P-0.5SV15	570-1014-2	20	17.4	16.4	4.5	10.4	10	11	20
FX20-40P-0.5SV15	570-1001-0	40	22.4	21.4	9.5	15.4	20	21	40
FX20-60P-0.5SV15	570-1002-3	60	27.4	26.4	14.5	20.4	30	31	60
FX20-80P-0.5SV15	570-1003-6	80	32.4	31.4	19.5	25.4	40	41	80
FX20-100P-0.5SV15	570-1004-9	100	37.4	36.4	24.5	30.4	50	51	100
FX20-120P-0.5SV15	570-1005-1	120	42.4	41.4	29.5	35.4	60	61	120
FX20-140P-0.5SV15	570-1006-4	140	47.4	46.4	34.5	40.4	70	71	140

[FX20-**P-0.5SV20]

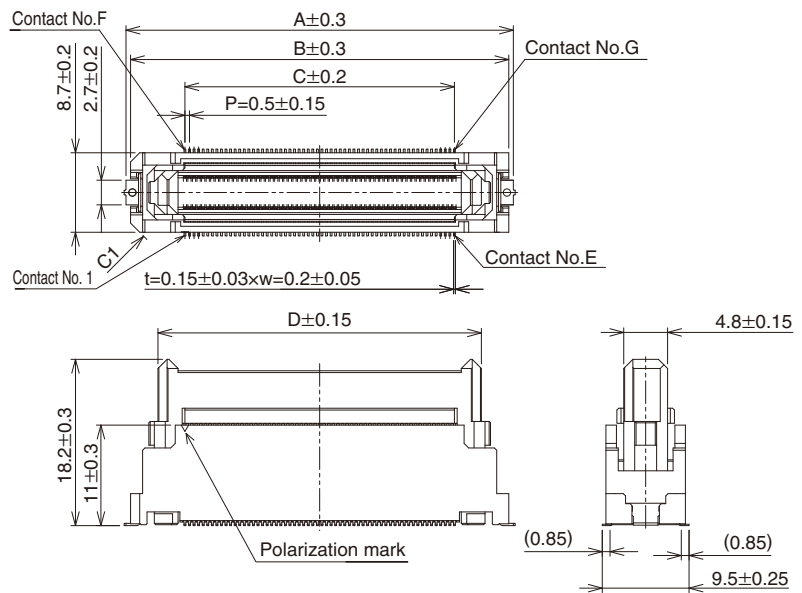

Unit : mm

Part No.	HRS No.	No. of contacts	A	B	C	D	E	F	G
FX20-20P-0.5SV20	570-1015-5	20	17.4	16.4	4.5	10.4	10	11	20
FX20-40P-0.5SV20	570-1007-7	40	22.4	21.4	9.5	15.4	20	21	40
FX20-60P-0.5SV20	570-1008-0	60	27.4	26.4	14.5	20.4	30	31	60
FX20-80P-0.5SV20	570-1009-2	80	32.4	31.4	19.5	25.4	40	41	80
FX20-100P-0.5SV20	570-1010-1	100	37.4	36.4	24.5	30.4	50	51	100
FX20-120P-0.5SV20	570-1011-4	120	42.4	41.4	29.5	35.4	60	61	120
FX20-140P-0.5SV20	570-1012-7	140	47.4	46.4	34.5	40.4	70	71	140

●Right angle receptacle

[FX20-**S-0.5SH]

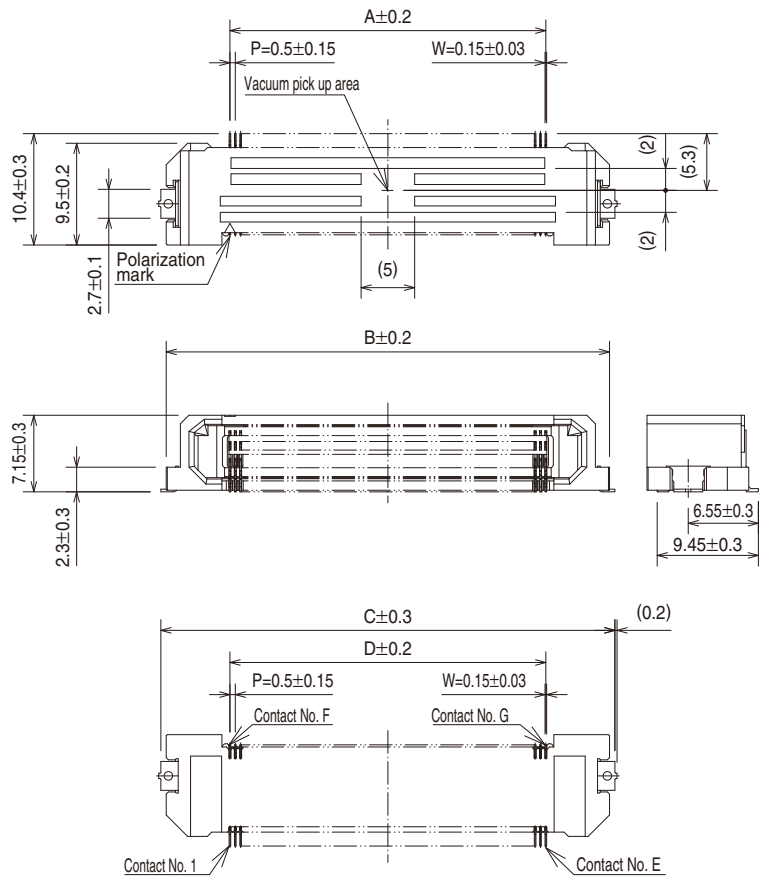

Unit : mm

Part No.	HRS No.	No. of contacts	A	B	C	D	E	F	G
FX20-20S-0.5SH	570-1611-1	20	4.5	16.4	17.4	4.5	10	11	20
FX20-40S-0.5SH	570-1601-8	40	9.5	21.4	22.4	9.5	20	21	40
FX20-60S-0.5SH	570-1602-0	60	14.5	26.4	27.4	14.5	30	31	60
FX20-80S-0.5SH	570-1603-3	80	19.5	31.4	32.4	19.5	40	41	80
FX20-100S-0.5SH	570-1604-6	100	24.5	36.4	37.4	24.5	50	51	100
FX20-120S-0.5SH	570-1605-9	120	29.5	41.4	42.4	29.5	60	61	120
FX20-140S-0.5SH	570-1606-1	140	34.5	46.4	47.4	34.5	70	71	140

Recommended PCB layout

(PCB thickness: $t = 1.6$ mm / Stencil thickness: $t = 0.15$ mm, $t = 0.12$ mm)

● Straight receptacle

FX20-**-S-0.5SV
FX20-**-S-0.5SV10

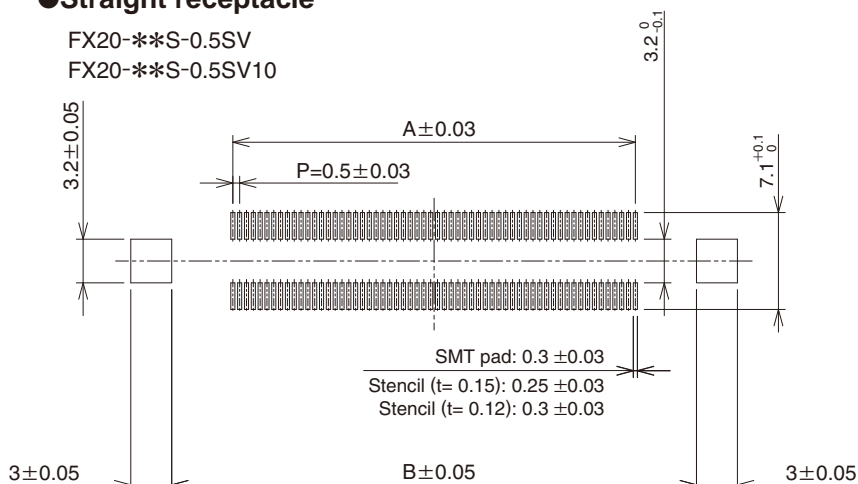

Unit: mm

**	A	B
20	4.5	13.46
40	9.5	18.46
60	14.5	23.46
80	19.5	28.46
100	24.5	33.46
120	29.5	38.46
140	34.5	43.46

● Straight header

FX20-**-P-0.5SV15
FX20-**-P-0.5SV20

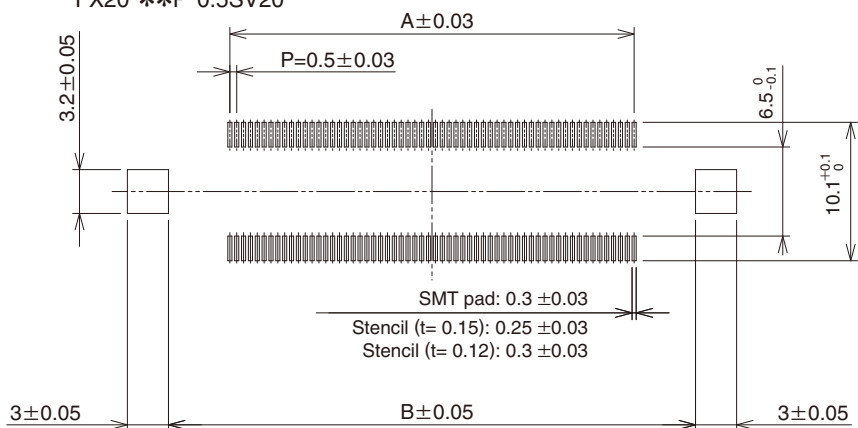

Unit: mm

**	A	B
20	4.5	13.46
40	9.5	18.46
60	14.5	23.46
80	19.5	28.46
100	24.5	33.46
120	29.5	38.46
140	34.5	43.46

● Right angle receptacle

FX20-**-S-0.5SH

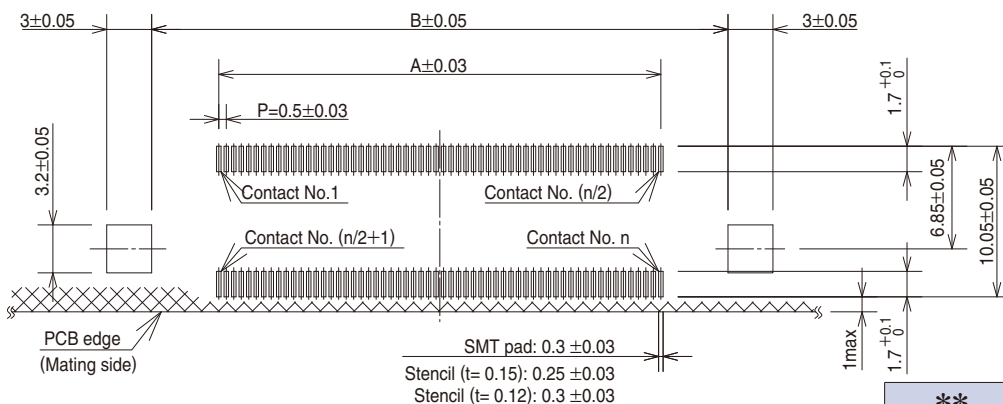

Unit: mm

**	A	B
20	4.5	13.46
40	9.5	18.46
60	14.5	23.46
80	19.5	28.46
100	24.5	33.46
120	29.5	38.46
140	34.5	43.46

◆Tray package drawing

●Straight receptacle

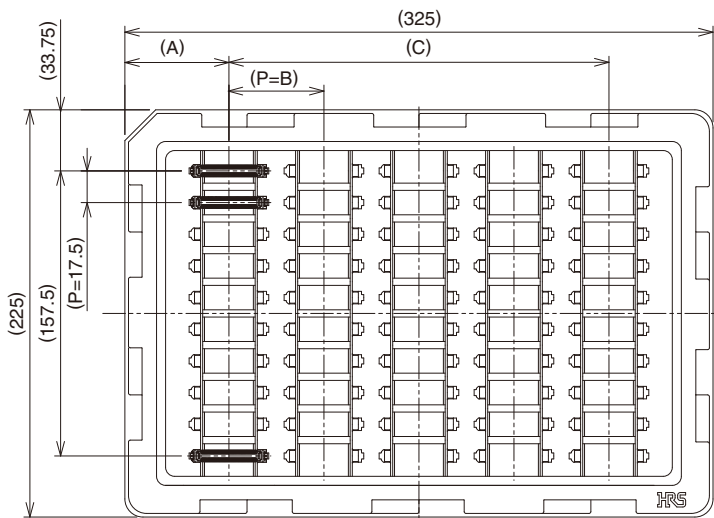

Unit: mm

Part No.	Quantity	A	B	C
FX20-20S-0.5SV	90	42.5	30	240
FX20-20S-0.5SV10				
FX20-40S-0.5SV	80	40	35	245
FX20-40S-0.5SV10				
FX20-60S-0.5SV	70	50	37.5	225
FX20-60S-0.5SV10				
FX20-80S-0.5SV	60	50	45	225
FX20-80S-0.5SV10				
FX20-100S-0.5SV	60	47.5	46	230
FX20-100S-0.5SV10				
FX20-120S-0.5SV	50	57.5	52.5	210
FX20-120S-0.5SV10				
FX20-140S-0.5SV	50	51.5	55.5	222
FX20-140S-0.5SV10				

●Straight header

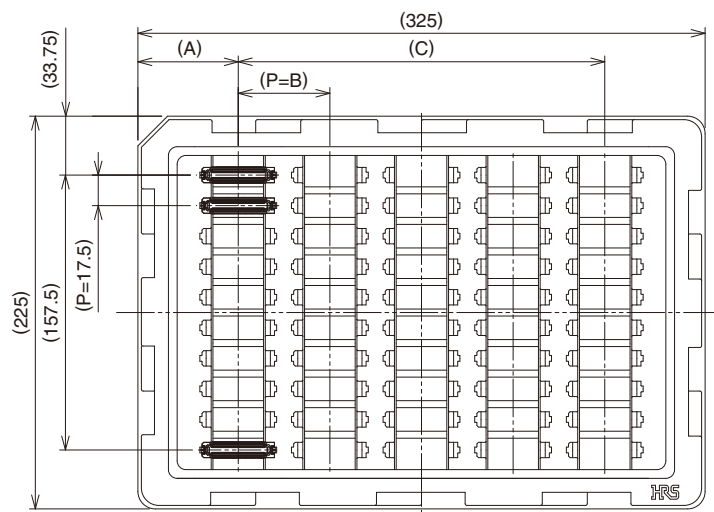

Unit: mm

Part No.	Quantity	A	B	C
FX20-20P-0.5SV15	90	42.5	30	240
FX20-20P-0.5SV20				
FX20-40P-0.5SV15	80	40	35	245
FX20-40P-0.5SV20				
FX20-60P-0.5SV15	70	50	37.5	225
FX20-60P-0.5SV20				
FX20-80P-0.5SV15	60	50	45	225
FX20-80P-0.5SV20				
FX20-100P-0.5SV15	60	47.5	46	230
FX20-100P-0.5SV20				
FX20-120P-0.5SV15	50	57.5	52.5	210
FX20-120P-0.5SV20				
FX20-140P-0.5SV15	50	51.5	55.5	222
FX20-140P-0.5SV20				

●Right angle receptacle

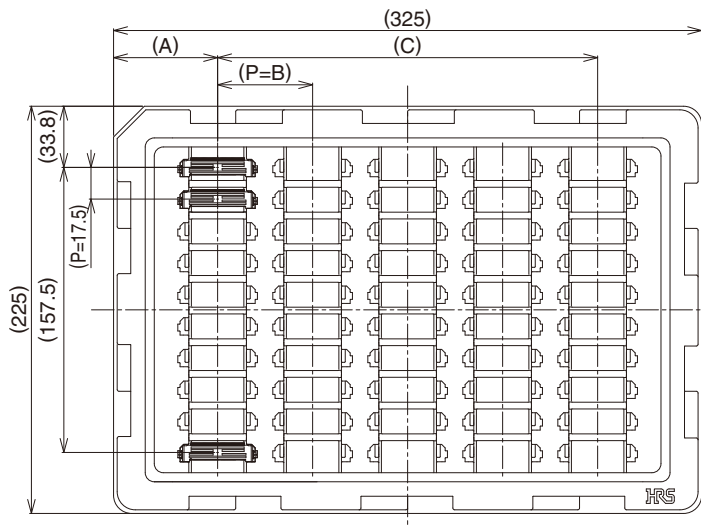

Unit: mm

Part No.	Quantity	A	B	C
FX20- 20S-0.5SH	90	42.5	30	240
FX20- 40S-0.5SH	80	40	35	245
FX20- 60S-0.5SH	70	50	37.5	225
FX20- 80S-0.5SH	60	50	45	225
FX20-100S-0.5SH	60	47.5	46	230
FX20-120S-0.5SH	50	57.5	52.5	210
FX20-140S-0.5SH	50	51.5	55.5	222

◆ Recommended Solder

● This temperature profile is based on the setting conditions shown below and is for reference only. For individual applications, the temperature profile may vary in accordance with the conditions. Please confirm the profile before mounting.

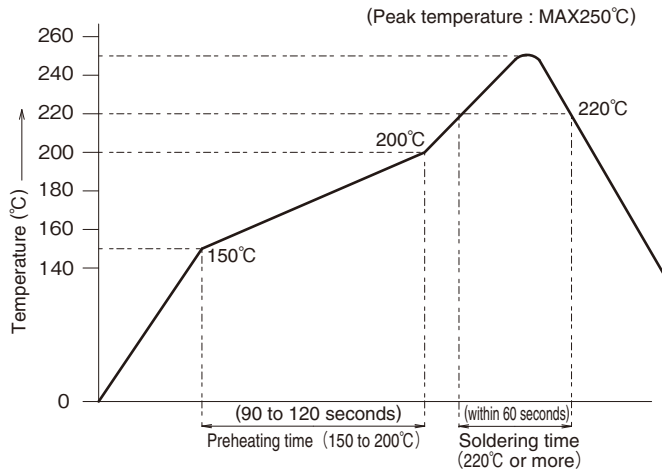

<Applicable Conditions>

Test PCB dimensions : 110 × 50 × 1.6mm
 Material : Glass epoxy
 Solder composition : Sn- 3 Ag- 0.5 Cu
 Flux content : 11 wt%
 Stencil thickness : 0.12mm, 0.15mm
 Reflow count : 2 times
 Reflow area : 220°C or more, 60 sec max.
 Preheating unit : 150 to 200°C, 90 to 120 sec

* The temperature profile may vary due to external conditions such as the type of cream solder, manufacturer, and board size. Please contact the solder manufacturer for their specifications.

◆ Cleaning condition

● Organic solvent-based cleaning

Solvent type	Room temperature cleaning	Heated cleaning
IPA (Isopropyl alcohol)	○	○

● Water based cleaning

When using water based cleaning agents (including terpene, and alkali saponifiers), pay special attention to how the cleaning agent will react to specific metals and plastics before selecting one of them. Various cleaning agent manufacturers publish reaction tables for their cleaning agents. Do not leave connectors with moisture remaining on them.

● Caution when washing

The electrical performance may deteriorate if the flux or cleaning detergent is left on the connector after the cleaning. Check thoroughly to ensure that there is no residue left on any of the surfaces.

◆ Precautions

● Tolerance clearance on mating

The effective contact length of each product is 1.5mm. In the mated condition, the header and receptacle shall have a clearance or gap between them of no more than 1mm.

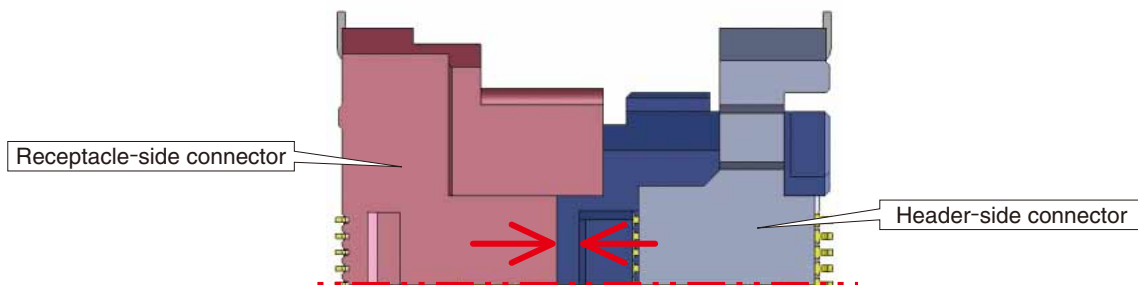

●Using excessive force when mating these connectors may result in damage and alter their performance. Although they are designed with a prevention mechanism to resist incorrect insertion, do not forcibly mate them. Before mating the connector, confirm the connector polarity as shown below.

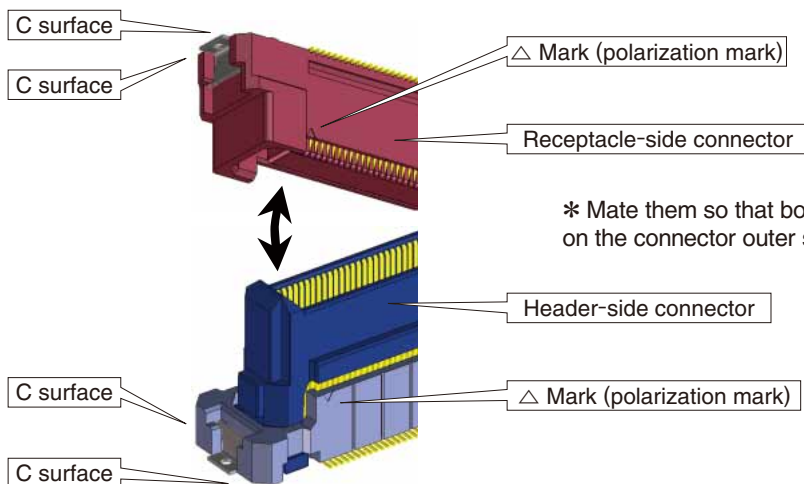

* Mate them so that both C surfaces or both △ marks on the connector outer surface are aligned.

●Provide another form of support to the PCB. This connector was not designed to be the main form of support.

●Mating and un-mating with excessive prying force or rotating force may result in damage to the connector or contact failure.



If you have no choice but to mate and un-mate with prying force based on your usage environment, use a point as a pivot shown by △ mark in the figure below when you apply those forces. The point shall be a certain distance away from the connector end and has equal or higher height of the mating height. (Please refer to the guideline for details including the relationship between the pivot position and the connector position, and usage examples.)

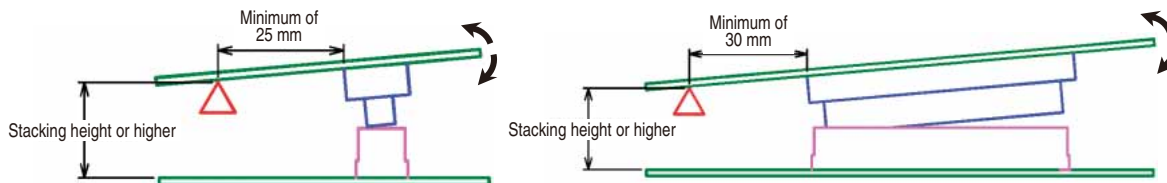

●This connector has a floating structure, but the floating range may vary depending on the height of connector on the header side (which has a floating mechanism).

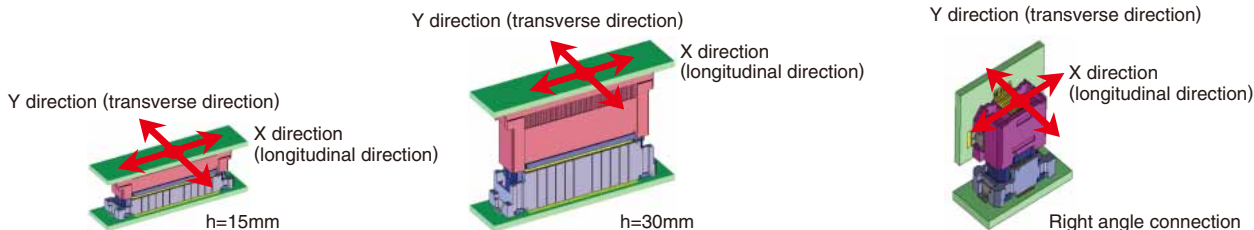

Header-side	Receptacle-side	Stack height	Floating range	
			X direction (longitudinal direction)	Y direction (transverse direction)
FX20-**P-0.5SV15	FX20-**S-0.5SV	15mm	0.6mm	0.6mm
FX20-**P-0.5SV20		20mm	0.8mm	0.6mm
FX20-**P-0.5SV15	FX20-**S-0.5SV10	25mm	0.6mm	0.6mm
FX20-**P-0.5SV20		30mm	0.8mm	0.6mm
FX20-**P-0.5SV15	FX20-**S-0.5SH	—	0.6mm	0.6mm
FX20-**P-0.5SV20		—	0.8mm	0.6mm

- If the right angle type connector is positioned too far back from the recommended connector mounting position, the straight type connector will make contact with the PCB, and these may lead to damaged product or abnormal connections.

The location of right angle type SMT pad should be set to within 1mm from the edge of the PCB, and the mounting position should be set so that the clearance from the head of the connector to the edge of the PCB is 1.3mm or less.

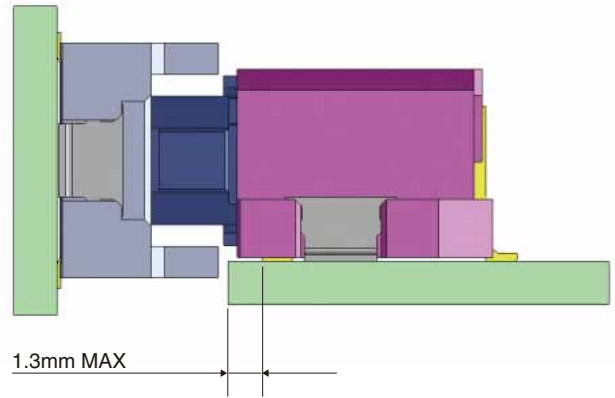
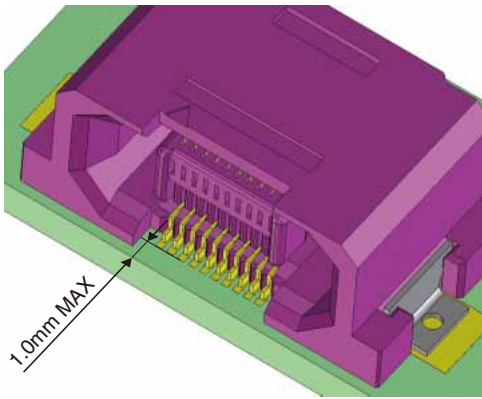

MEMO :

A series of horizontal dashed lines for writing a memo.

USA:
HIROSE ELECTRIC (U.S.A.), INC. HEADQUARTERS CHICAGO OFFICE
 2300 Warrenville Road, Suite 150,
 Downers Grove, IL 60515
 Phone : +1-630-282-6700
<http://www.hirose.com/us/>

USA:
HIROSE ELECTRIC (U.S.A.), INC. SAN JOSE OFFICE
 2841 Junction Ave, Suite 200
 San Jose, CA. 95134
 Phone : +1-408-253-9640
 Fax : +1-408-253-9641
<http://www.hirose.com/us/>

USA:
HIROSE ELECTRIC (U.S.A.), INC. DETROIT OFFICE (AUTOMOTIVE)
 17197 N. Laurel Park Drive, Suite 253,
 Livonia, MI 48152
 Phone : +1-734-542-9963
 Fax : +1-734-542-9964
<http://www.hirose.com/us/>

USA:
HIROSE ELECTRIC (U.S.A.), INC. BOSTON OFFICE
 300 Brickstone Square Suite 201,
 Andover, MA 01810
 Phone : +1-978-662-5255

THE NETHERLANDS:
HIROSE ELECTRIC EUROPE B.V.
 Hogehillweg #8 1101 CC Amsterdam Z-0
 Phone : +31-20-6557460
 Fax : +31-20-6557469
<http://www.hirose.com/eu/>

GERMANY:
HIROSE ELECTRIC EUROPE B.V. GERMAN BRANCH
 Schoenbergstr. 20, 73760 ostfildern
 Phone : +49-711-456002-1
 Fax : +49-711-456002-299
<http://www.hirose.com/eu/>

GERMANY:
HIROSE ELECTRIC EUROPE B.V. NUREMBERG OFFICE
 Neumeyerstrasse 22-26, 90411 Nurnberg
 Phone : +49-911 32 68 89 63
 Fax : +49-911 32 68 89 69
<http://www.hirose.com/eu/>

GERMANY:
HIROSE ELECTRIC EUROPE B.V. HANOVER OFFICE
 Bayernstr. 3, Haus C 30855 Langenhagen, Germany
 Phone : +49-511 97 82 61 30
 Fax : +49-511 97 82 61 35
<http://www.hirose.com/eu/>

FRANCE:
HIROSE ELECTRIC EUROPE B.V. PARIS OFFICE
 130 Avenue Joseph Kessel, Bat E, 78960
 Voisins le Bretonneux, France
 Phone : +33-1-85764886
 Fax : +33-1-85764823
<http://www.hirose.com/eu/>

UNITED KINGDOM:
HIROSE ELECTRIC EUROPE BV (UK BRANCH)
 4 Newton Court, Kelvin Drive, Knowlhill,
 Milton Keynes, MK5 8NH
 Phone : +44-1908 202050
 Fax : +44-1908 202058
<http://www.hirose.com/eu/>

CHINA:
HIROSE ELECTRIC (CHINA) CO., LTD. (SHANGHAI, HEADQUARTERS)
 18, Enterprise Center Tower 2, 209# Gong He
 Road, Jing'an District, Shanghai, CHINA 200070
 Phone : +86-21-6391-3355
 Fax : +86-21-6391-3335
<http://www.hirose.com/cn/>

CHINA:
HIROSE ELECTRIC (CHINA) CO.,LTD. BEIJING BRANCH
 A1001, Ocean International Center, Building 56# East 4th
 Ring Middle Road, ChaoYang District, Beijing, 100025
 Phone : +86-10-5165-9332
 Fax : +86-10-5908-1381
<http://www.hirose.com/cn/>

CHINA:
HIROSE ELECTRIC (CHINA) CO., LTD. SHENZHEN BRANCH
 Room 09-13, 19/F, Office Tower Shun Hing Square, Di Wang Commercial Centre,
 5002 Shen Nan Dong Road, Shenzhen City, Guangdong Province, 518008
 Phone : +86-755-8207-0851
 Fax : +86-755-8207-0873
<http://www.hirose.com/cn/>

HONG KONG:
HIROSE ELECTRIC HONGKONG TRADING CO., LTD.
 Room 1001, West Wing, Tsim Sha Tsui Centre, 66
 Mody Road, Tsim Sha Tsui East, Kowloon, Hong Kong
 Phone : +852-2803-5338
 Fax : +852-2591-6560
<http://www.hirose.com/hk/>

TAIWAN:
HIROSE ELECTRIC TAIWAN CO., LTD.
 103 8F, No.87, Zhengzhou Rd., Taipei
 Phone : +886-2-2555-7377
 Fax : +886-2-2555-7355
<http://www.hirose.com/tw/>

KOREA:
HIROSE KOREA CO.,LTD.
 143, Gongdan 1-daero, Siheung-si,
 Gyeonggi-do, 15084, Korea
 Phone : +82-31-496-7000
 Fax : +82-31-496-7100
<http://www.hirose.co.kr/>

SINGAPORE:
HIROSE ELECTRIC SINGAPORE PTE. LTD.
 03, Anson Road, #20-01, Springleaf Tower,
 Singapore 079909
 Phone : +65-6324-6113
 Fax : +65-6324-6123
<http://www.hirose.com/sg/>

INDIA:
HIROSE ELECTRIC SINGAPORE PTE. LTD. DELHI LIAISON OFFICE
 Office NO.552, Regus-Green Boulevard, Level5, Tower C,
 Sec62, Plot B-9A, Block B, Noida, 201301, Uttar Pradesh, India
 Phone : +91-12-660-8018
 Fax : +91-120-4804949
<http://www.hirose.com/sg/>

INDIA:
HIROSE ELECTRIC SINGAPORE PTE. LTD. BANGALORE LIAISON OFFICE
 Unit No-403, 4th Floor, No-84, Barton Centre, Mahatma
 Gandhi (MG) Road, Bangalore 560 001, Karnataka, India
 Phone : +91-80-4120 1907
 Fax : +91-80-4120 9908
<http://www.hirose.com/sg/>

MALAYSIA:
PENANG REPRESENTATIVE OFFICE
 73-3-1, Ideal@The One, Jalan Mahsuri, Bayan
 Lepas Penang, 11950, Malaysia
 Phone : +604-648-5536
<http://www.hirose.com/sg/>

THAILAND:
BANGKOK OFFICE (REPRESENTATIVE OFFICE)
 Unit 4703, 47th FL., 1 Empire Tower, South Sathorn
 Road, Yannawa, Sathorn, Bangkok 10120 Thailand
 Phone : +66-2-686-1255
 Fax : +66-2-686-3433
<http://www.hirose.com/sg/>



HIROSE ELECTRIC CO.,LTD.

2-6-3,Nakagawa Chuoh,Tsuzuki-Ku,Yokohama-Shi 224-8540,JAPAN
 TEL: +81-45-620-3526 Fax: +81-45-591-3726
<http://www.hirose.com>
<http://www.hirose-connectors.com>